



Model created in COMSOL Multiphysics 6.4

# Notch Approximation in Low-Cycle Fatigue Analysis of Cylinder with a Hole

## Introduction

---

A load carrying component of a structure is subjected to multiaxial cyclic loading during which a localized yielding of the material occurs. In this model you perform a low cycle fatigue analysis of the part based on the Smith–Watson–Topper (SWT) model. Due to localized yielding, you can use two methods to obtain the stress and strain distributions for the fatigue evaluation. The first method is an elastoplastic analysis with linear kinematic hardening, while the second is a linear elastic analysis with Neuber correction for plasticity, based on the Ramberg–Osgood model. This example explores the second method. In the model [Elastoplastic Low-Cycle Fatigue Analysis of Cylinder with a Hole](#), the same problem is solved using the full elastoplastic approach.

## Model Definition

---

### GEOMETRY

A cylinder contains a hole, drilled perpendicularly to its axis. The outer and inner diameters of the cylinder are 200 and 180 mm, respectively. Its height is 100 mm. The diameter of the hole is 20 mm. The cylinder is loaded by an axial force that varies in time.

As the structure and loading contain several symmetries, you can model only 1/8 of the cylinder, as shown in [Figure 1](#).

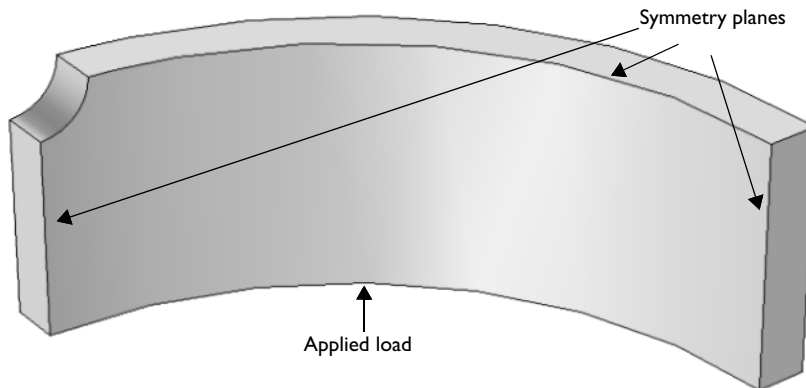

*Figure 1: Model geometry with constrained and loaded faces.*

### MATERIAL PROPERTIES

- Elastic data: Isotropic with  $E = 210$  GPa,  $\nu = 0.3$

- Cyclic Ramberg–Osgood plasticity data:  $K' = 1550$  MPa,  $n' = 0.16$
- Fatigue parameters for the SWT equation:
  - $\sigma_f' = 1323$  MPa
  - $b = -0.097$
  - $\epsilon_f' = 0.375$
  - $c = -0.60$

#### **CONSTRAINTS**

Apply symmetry conditions on the three symmetry sections shown in [Figure 1](#).

#### **LOAD**

The loaded boundary of the cylinder is subjected to a pressure varying between +200 MPa and -200 MPa.

## Results and Discussion

The von Mises stress distribution at maximum load is shown in [Figure 2](#). Notice that the yield limit (380 = MPa) is extensively exceeded, so in reality significant plastic strains can be expected.

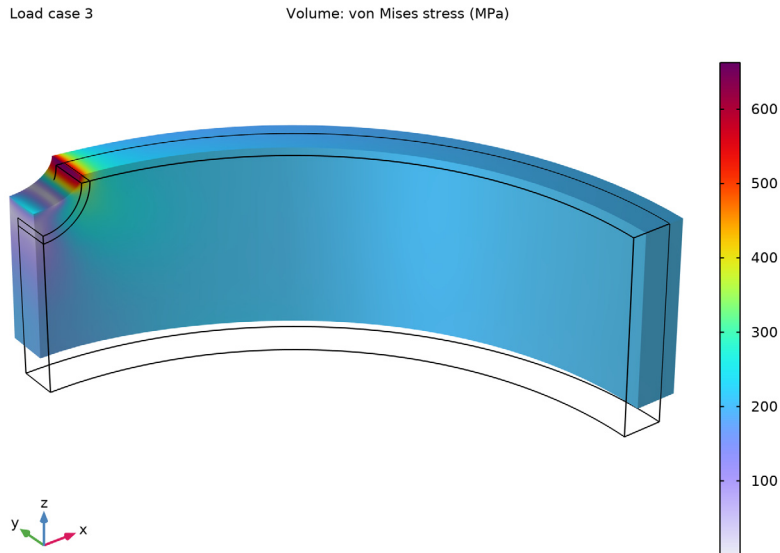

*Figure 2: von Mises stress level at the first maximum load.*

The computed number of cycles to fatigue is shown in [Figure 3](#). It is slightly below 5000 cycles.

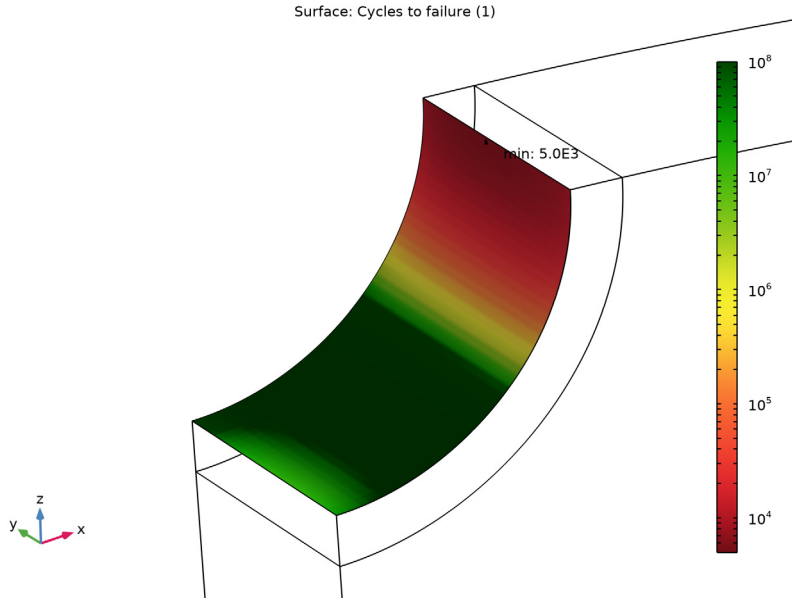

Figure 3: The distribution of expected number of cycles at the hole.

### *Notes About the COMSOL Implementation*

---

When using the elastic approach to low cycle fatigue, it is only the peak loads that are important, not the load cycle as such. The model includes both the maximum and the minimum loads, since some of the criteria are sensitive to the sign of the stresses. It is also necessary to include the “zero” load case, which contains no loads.

---

**Application Library path:** Fatigue\_Module/Strain\_Based/  
cylinder\_with\_hole\_elastic

---

### *Modeling Instructions*



---

From the **File** menu, choose **New**.

#### **NEW**

In the **New** window, click  **Model Wizard**.

## MODEL WIZARD

- 1 In the **Model Wizard** window, click  **3D**.
- 2 In the **Select Physics** tree, select **Structural Mechanics > Solid Mechanics (solid)**.
- 3 Click **Add**.
- 4 Click  **Study**.
- 5 In the **Select Study** tree, select **General Studies > Stationary**.
- 6 Click  **Done**.

## GEOMETRY I

- 1 In the **Model Builder** window, under **Component 1 (comp1)** click **Geometry 1**.
- 2 In the **Settings** window for **Geometry**, locate the **Units** section.
- 3 From the **Length unit** list, choose **mm**.



### *Cylinder 1 (cyl1)*

- 1 In the **Geometry** toolbar, click  **Cylinder**.
- 2 In the **Settings** window for **Cylinder**, locate the **Size and Shape** section.
- 3 In the **Radius** text field, type 100.
- 4 In the **Height** text field, type 100.

### *Cylinder 2 (cyl2)*

- 1 Right-click **Cylinder 1 (cyl1)** and choose **Duplicate**.
- 2 In the **Settings** window for **Cylinder**, locate the **Size and Shape** section.
- 3 In the **Radius** text field, type 90.

### *Difference 1 (dif1)*



- 1 In the **Geometry** toolbar, click  **Booleans and Partitions** and choose **Difference**.
- 2 Select the object **cyl1** only.
- 3 In the **Settings** window for **Difference**, locate the **Difference** section.
- 4 Click to select the  **Activate Selection** toggle button for **Objects to subtract**.
- 5 Select the object **cyl2** only.
- 6 Click  **Build All Objects**.

### *Cylinder 3 (cyl3)*



- 1 In the **Geometry** toolbar, click  **Cylinder**.
- 2 In the **Settings** window for **Cylinder**, locate the **Size and Shape** section.
- 3 In the **Radius** text field, type 10.

- 4 In the **Height** text field, type 220.
- 5 Locate the **Position** section. In the **y** text field, type -110.
- 6 In the **z** text field, type 50.
- 7 Locate the **Axis** section. From the **Axis type** list, choose **y-axis**.
- 8 Click  **Build All Objects**.



#### *Difference 2 (dif2)*

- 1 In the **Geometry** toolbar, click  **Booleans and Partitions** and choose **Difference**.
- 2 Select the object **dif1** only.
- 3 In the **Settings** window for **Difference**, locate the **Difference** section.
- 4 Click to select the  **Activate Selection** toggle button for **Objects to subtract**.
- 5 Select the object **cyl3** only.
- 6 Click  **Build All Objects**.



#### *Cylinder 4 (cyl4)*

- 1 In the **Geometry** toolbar, click  **Cylinder**.
- 2 In the **Settings** window for **Cylinder**, locate the **Size and Shape** section.
- 3 In the **Radius** text field, type 12.
- 4 In the **Height** text field, type 220.
- 5 Locate the **Position** section. In the **y** text field, type -110.
- 6 In the **z** text field, type 50.
- 7 Locate the **Axis** section. From the **Axis type** list, choose **y-axis**.
- 8 Click  **Build All Objects**.



#### *Partition Domains 1 (pard1)*

- 1 In the **Geometry** toolbar, click  **Booleans and Partitions** and choose **Partition Domains**.
- 2 On the object **dif2**, select Domain 1 only.
- 3 In the **Settings** window for **Partition Domains**, locate the **Partition Domains** section.
- 4 From the **Partition with** list, choose **Objects**.
- 5 Select the object **cyl4** only.
- 6 Clear the **Keep objects** checkbox.
- 7 Click  **Build All Objects**.

### Block 1 (blk1)

- 1 In the **Geometry** toolbar, click  **Block**.
- 2 In the **Settings** window for **Block**, locate the **Size and Shape** section.
- 3 In the **Width** text field, type 100.
- 4 In the **Depth** text field, type 100.
- 5 In the **Height** text field, type 50.
- 6 Click  **Build All Objects**.

### Intersection 1 (int1)

- 1 In the **Geometry** toolbar, click  **Booleans and Partitions** and choose **Intersection**.
- 2 Click in the **Graphics** window and then press Ctrl+A to select both objects.
- 3 In the **Settings** window for **Intersection**, click  **Build All Objects**.
- 4 Click the  **Zoom Extents** button in the **Graphics** toolbar.

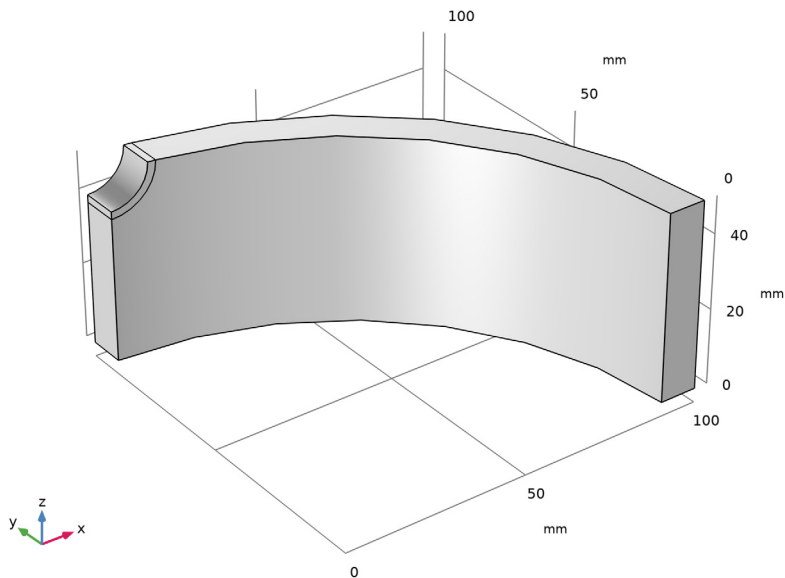

## SOLID MECHANICS (SOLID)

### Symmetry 1

- 1 In the **Physics** toolbar, click  **Boundaries** and choose **Symmetry**.
- 2 Select Boundaries 1, 4, and 10–12 only.

### Boundary Load 1

- 1 In the **Physics** toolbar, click  **Boundaries** and choose **Boundary Load**.
- 2 Select Boundary 3 only.
- 3 In the **Settings** window for **Boundary Load**, locate the **Force** section.
- 4 Specify the  $\mathbf{f}_A$  vector as

0	x
0	y
-200 [MPa]	z

- 5 In the **Physics** toolbar, click  **Load Group** and choose **New Load Group**.

## MATERIALS

### Material 1 (mat1)

- 1 In the **Model Builder** window, under **Component 1 (comp1)** right-click **Materials** and choose **Blank Material**.
- 2 In the **Settings** window for **Material**, locate the **Material Contents** section.
- 3 In the table, enter the following settings:

Property	Variable	Value	Unit	Property group
Young's modulus	E	210 [GPa]	Pa	Young's modulus and Poisson's ratio
Poisson's ratio	nu	0.3		Young's modulus and Poisson's ratio
Density	rho	0	kg/m <sup>3</sup>	Basic

## MESH 1

### Mapped 1



- 1 In the **Mesh** toolbar, click  **More Generators** and choose **Mapped**.
- 2 Select Boundaries 5 and 7 only.

### Size 1

- 1 Right-click **Mapped 1** and choose **Size**.
- 2 In the **Settings** window for **Size**, locate the **Element Size** section.
- 3 Click the **Custom** button.
- 4 Locate the **Element Size Parameters** section.

5 Select the **Maximum element size** checkbox. In the associated text field, type 1.

*Swept /*

- 1 In the **Mesh** toolbar, click  **Swept**.
- 2 In the **Settings** window for **Swept**, locate the **Domain Selection** section.
- 3 From the **Geometric entity level** list, choose **Domain**.
- 4 Select Domain 2 only.
- 5 Click  **Build All**.

*Free Tetrahedral /*

- 1 In the **Mesh** toolbar, click  **Free Tetrahedral**.
- 2 In the **Settings** window for **Free Tetrahedral**, click  **Build All**.

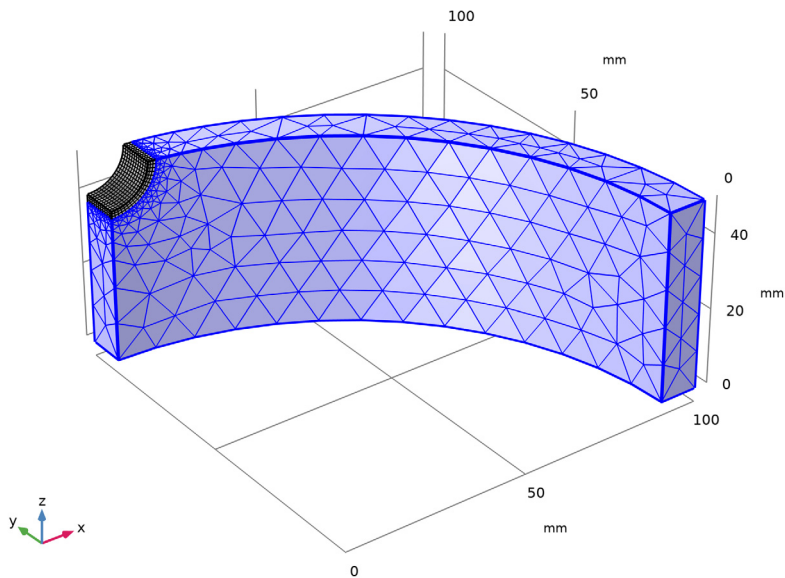

**STUDY I**

*Step 1: Stationary*

- 1 In the **Model Builder** window, under **Study I** click **Step 1: Stationary**.
- 2 In the **Settings** window for **Stationary**, click to expand the **Study Extensions** section.

3 Select the **Define load cases** checkbox.

In an analysis of this type you should always supply the maximum and the minimum load, and also a zero solution.

4 Click **Add** three times.

5 In the table, enter the following settings:

Load case	Igl	Weight
Load case 1	√	0
Load case 2	√	1.0
Load case 3	√	-1.0

6 In the **Study** toolbar, click  **Compute**.

## RESULTS

### *Volume 1*

1 In the **Model Builder** window, expand the **Results > Stress (solid)** node, then click **Volume 1**.

2 In the **Settings** window for **Volume**, locate the **Expression** section.

3 From the **Unit** list, choose **MPa**.

4 In the **Stress (solid)** toolbar, click  **Plot**.

## ADD PHYSICS

1 In the **Home** toolbar, click  **Add Physics** to open the **Add Physics** window.

2 Go to the **Add Physics** window.

3 In the tree, select **Structural Mechanics > Fatigue (ftg)**.

4 Find the **Physics interfaces in study** subsection. In the table, clear the **Solve** checkbox for **Study 1**.

5 Click the **Add to Component 1** button in the window toolbar.

6 In the **Home** toolbar, click  **Add Physics** to close the **Add Physics** window.

## FATIGUE (FTG)

### *Strain-Based 1*

1 In the **Physics** toolbar, click  **Boundaries** and choose **Strain-Based**.

2 Select Boundary 7 only.

As the elastic approach to strain based fatigue is based on a notch assumption, it only makes sense to select boundaries at the hole.

3 In the **Settings** window for **Strain-Based**, locate the **Fatigue Model Selection** section.

4 From the **Solution type** list, choose **Elastic solution with notch assumption**.

5 Locate the **Solution Field** section. From the **Physics interface** list, choose **Solid Mechanics (solid)**.

## MATERIALS

### *Material 2 (mat2)*

1 In the **Model Builder** window, under **Component 1 (comp1)** right-click **Materials** and choose **Blank Material**.

2 In the **Settings** window for **Material**, locate the **Geometric Entity Selection** section.

3 From the **Geometric entity level** list, choose **Boundary**.

4 From the **Selection** list, choose **All boundaries**.

5 Locate the **Material Contents** section. In the table, enter the following settings:

Property	Variable	Value	Unit	Property group
Fatigue ductility coefficient	epsilonfn_CM	0.375	l	Coffin-Manson
Fatigue ductility exponent	c_CM	-0.60	l	Coffin-Manson
Fatigue strength coefficient	sigmaf_Basquin	1323[MPa]	Pa	Basquin
Fatigue strength exponent	b_Basquin	-0.097	l	Basquin
Young's modulus	E	solid.E	Pa	Basic
Poisson's ratio	nu	solid.nu	l	Basic
Cyclic hardening coefficient	K_ROcyclic	1550[MPa]	Pa	Ramberg-Osgood
Cyclic hardening exponent	n_ROcyclic	0.16	l	Ramberg-Osgood

## ADD STUDY

1 In the **Home** toolbar, click  **Add Study** to open the **Add Study** window.

2 Go to the **Add Study** window.

- 3 Find the **Physics interfaces in study** subsection. In the table, clear the **Solve** checkbox for **Solid Mechanics (solid)**.
- 4 Find the **Studies** subsection. In the **Select Study** tree, select **Preset Studies for Selected Physics Interfaces > Fatigue**.
- 5 Click the **Add Study** button in the window toolbar.
- 6 In the **Home** toolbar, click  **Add Study** to close the **Add Study** window.

## STUDY 2

### *Step 1: Fatigue*

- 1 In the **Settings** window for **Fatigue**, locate the **Values of Dependent Variables** section.
- 2 Find the **Values of variables not solved for** subsection. From the **Settings** list, choose **User controlled**.
- 3 From the **Method** list, choose **Solution**.
- 4 From the **Study** list, choose **Study 1, Stationary**.
- 5 In the **Study** toolbar, click  **Compute**.

## RESULTS

### *Cycles to Failure (ftg)*

The plot of cycles to failure shown in [Figure 3](#) is created automatically.

- 1 In the **Model Builder** window, expand the **Cycles to Failure (ftg)** node.

### *Marker 1*

- 1 In the **Model Builder** window, expand the **Results > Cycles to Failure (ftg) > Surface 1** node, then click **Marker 1**.
- 2 In the **Settings** window for **Marker**, locate the **Text Format** section.
- 3 In the **Precision** text field, type 2.
- 4 In the **Cycles to Failure (ftg)** toolbar, click  **Plot**.