



Model created in COMSOL Multiphysics 6.4

Bracket – Random Vibration Fatigue

Introduction

In many engineering situations, structural components are subjected to loading that can be considered random. One example is found in consumer electronics, where vibrations exerted onto the circuit boards and similar components are more or less random. Another example is chassis-mounted auxiliary components on a commercial vehicle, where, contrary to engine vibrations, road induced vibrations are more or less random. In order to make a traditional fatigue assessment of components like these, one would need to take a very large time domain sample of the vibration, and perform a time domain fatigue analysis. In most situations, this is impractical. Instead, the statistical information about the vibration is used (typically a PSD spectrum), and fatigue assessments can instead be made using this information. In this example, it is shown how to perform a fatigue analysis of a bracket subjected to random vibration loading.

Model Definition

The bracket geometry can be seen in [Figure 1](#). The random vibration analysis for the bracket uses loading based on a power spectral density (PSD). The computations are based on the modal reduced-order model (ROM). Additional information regarding the model set up, including loading and boundary conditions, can be found in the documentation of the application *Bracket — Random Vibration Analysis*, found in the Structural Mechanics Module.

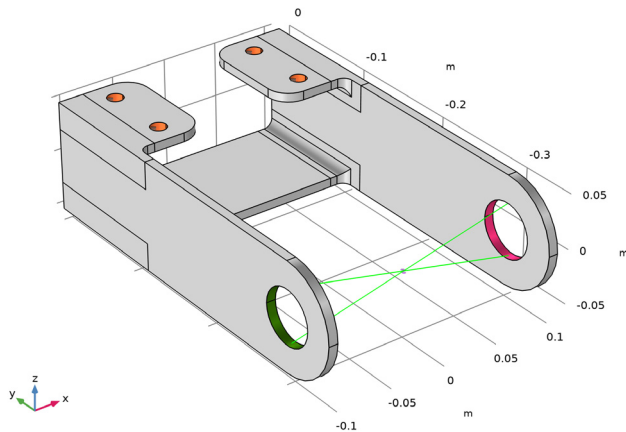

Figure 1: The bracket geometry.

Fatigue Analysis

Two cycle counting models are available when performing a random vibration fatigue analysis: the empirical model by Dirlik, and the Bendat (narrow-band) model. In this example, you will use the Dirlik and Bendat models, and pair them with the Basquin fatigue criterion to compute the fatigue life of the bracket. The Basquin fatigue criterion is given by:

$$\sigma_a = \sigma_f'(2N_f)^b \quad (1)$$

where, in this example, the amplitude stress σ_a is related to the number of cycles N_f through the parameters $\sigma_f' = 2.2$ GPa and $b = -0.25$.

Results and Discussion

[Figure 2](#) shows the computed fatigue life according to Dirlik's model, and [Figure 3](#) shows the computed fatigue life according to Bendat's model. Both models predict a critical point near a stress concentration, at a fillet. Bendat's model predicts a shorter life (17-

18 h) than Dirlik's model (20 h). Bendat's model tends to be conservative when the stress response is not narrow-band

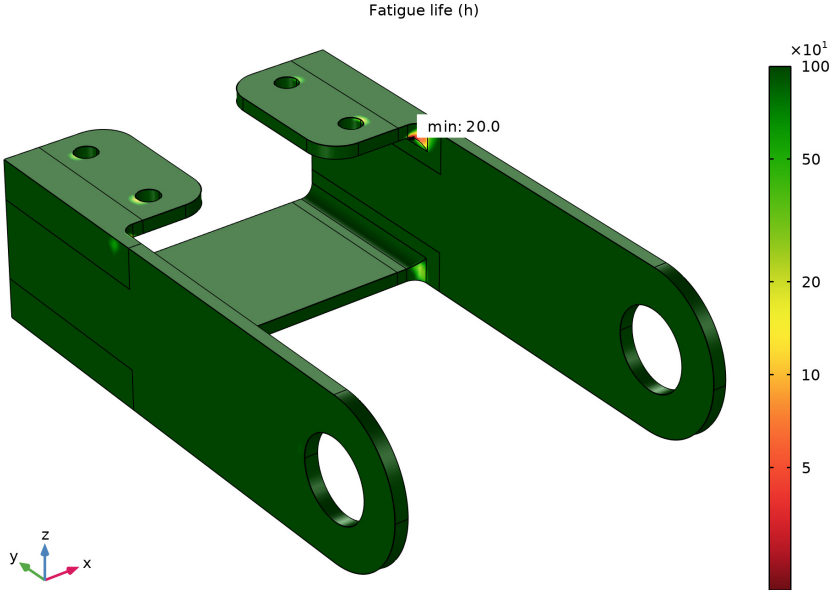

Figure 2: Fatigue life according to Dirlik.

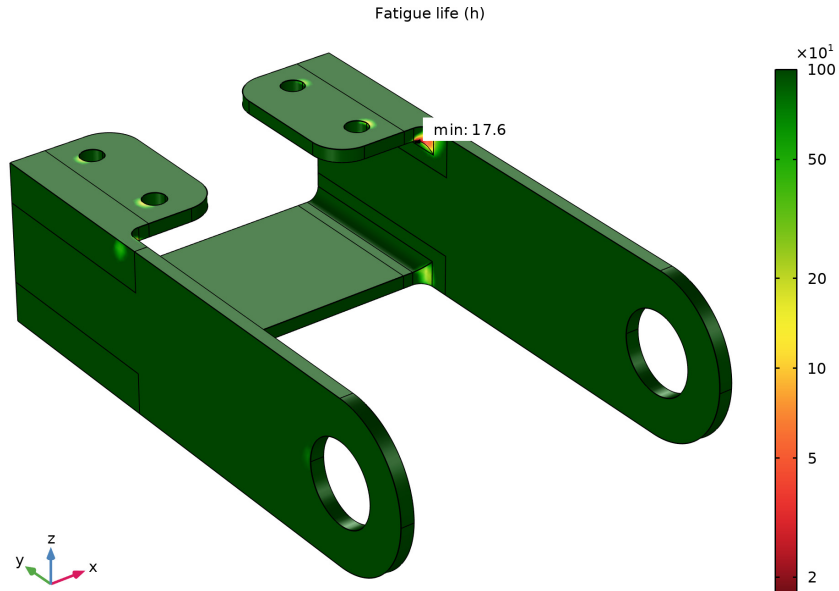

Figure 3: Fatigue life according to Bendat.

Application Library path: Fatigue_Module/Random_Vibration/
bracket_fatigue_random_vibration

Modeling Instructions

ROOT

This file serves as starting point for the fatigue computation.

APPLICATION LIBRARIES

- 1 From the **File** menu, choose **Application Libraries**.
- 2 In the **Application Libraries** window, select **Structural Mechanics Module > Tutorials > bracket_random_vibration** in the tree.
- 3 Click  **Open**.

GLOBAL DEFINITIONS

Parameters 1

- 1 In the **Model Builder** window, under **Global Definitions** click **Parameters 1**.
- 2 In the **Settings** window for **Parameters**, locate the **Parameters** section.
- 3 In the table, enter the following settings:

Name	Expression	Value	Description
b	-0.25	-0.25	Basquin exponent
sigf	2.2[GPa]	2.2E9 Pa	Basquin strength coefficient

COMPONENT 1 (COMP1)

From the **Home** menu, choose **Add Physics**.

ADD PHYSICS

- 1 Go to the **Add Physics** window.
- 2 In the tree, select **Structural Mechanics > Fatigue (ftg)**.
- 3 Click the **Add to Component 1** button in the window toolbar.
- 4 From the **Home** menu, choose **Add Physics**.

FATIGUE (FTG)

Random Vibration 1

- 1 In the **Model Builder** window, expand the **Component 1 (comp1)** node.
- 2 Right-click **Component 1 (comp1) > Fatigue (ftg)** and choose the boundary evaluation **Random Vibration**.
- 3 In the **Settings** window for **Random Vibration**, locate the **Boundary Selection** section.
- 4 From the **Selection** list, choose **All boundaries**.
- 5 Locate the **Moment Computation** section. From the **Random vibration model** list, choose **Random Vibration 1**.
- 6 From the **Physics interface for stresses** list, choose **Solid Mechanics (solid)**.
- 7 In the f_L text field, type 150.
- 8 In the f_U text field, type 800.
- 9 Locate the **Fatigue Model Selection** section. From the **Criterion** list, choose **Basquin**.
- 10 Locate the **Fatigue Model Parameters** section. From the σ_f' list, choose **User defined**. In the associated text field, type sigf.

11 From the b list, choose **User defined**. In the associated text field, type b .

Some parts of the structure are expected to experience infinite life. Use a life cutoff to facilitate the results visualization.

12 In the L_{cut} text field, type $1e3[h]$.

Random Vibration 2

1 In the **Model Builder** window, right-click **Random Vibration 1** and choose **Duplicate**.

2 In the **Settings** window for **Random Vibration**, locate the **Cycle Counting Model** section.

3 From the list, choose **Bendat**.

ADD STUDY

1 In the **Home** toolbar, click  **Add Study** to open the **Add Study** window.

2 Go to the **Add Study** window.

3 Find the **Studies** subsection. In the **Select Study** tree, select **Preset Studies for Selected Physics Interfaces > Fatigue > Fatigue**.

4 Click the **Add Study** button in the window toolbar.

5 In the **Home** toolbar, click  **Add Study** to close the **Add Study** window.

STUDY 3

In the **Study** toolbar, click  **Compute**.

RESULTS

Fatigue Life (Dirlik)

1 In the **Model Builder** window, expand the **Results > Fatigue Life (ftg)** node, then click **Fatigue Life (ftg)**.

2 In the **Settings** window for **3D Plot Group**, type **Fatigue Life (Dirlik)** in the **Label** text field.

Surface 1

1 In the **Model Builder** window, click **Surface 1**.

2 In the **Settings** window for **Surface**, click **Replace Expression** in the upper-right corner of the **Expression** section. From the menu, choose **Component 1 (comp1) > Fatigue > Random Vibration 1 > ftg.rand1.life - Fatigue life - s**.

3 Locate the **Expression** section. From the **Unit** list, choose **h**.

Marker 1

1 In the **Model Builder** window, expand the **Surface 1** node, then click **Marker 1**.

- 2 In the **Settings** window for **Marker**, locate the **Coloring and Style** section.
- 3 From the **Background color** list, choose **From theme**.
- 4 From the **Anchor point** list, choose **Lower left**.

Fatigue Life (Dirlik)

- 1 In the **Model Builder** window, under **Results** click **Fatigue Life (Dirlik)**.
- 2 In the **Fatigue Life (Dirlik)** toolbar, click  **Plot**.

Fatigue Life (Bendat)

- 1 Right-click **Fatigue Life (Dirlik)** and choose **Duplicate**.
- 2 In the **Settings** window for **3D Plot Group**, type **Fatigue Life (Bendat)** in the **Label** text field.
- 3 In the **Model Builder** window, expand the **Fatigue Life (Bendat)** node.

Surface 1

- 1 In the **Model Builder** window, expand the **Results > Fatigue Life (Bendat) > Surface 1** node, then click **Surface 1**.
- 2 In the **Settings** window for **Surface**, locate the **Expression** section.
- 3 In the **Expression** text field, type `ftg.rand2.life`.
- 4 In the **Fatigue Life (Bendat)** toolbar, click  **Plot**.