



Model created in COMSOL Multiphysics 6.4

# Electrocoating of a Car Door

## Introduction

---

Electrocoating (also known as E-coating) is an electrophoretical method for depositing paint onto electrically conducting objects. The method is widely used in various industries (for instance, in the automotive industry), where electrocoating is broadly used to apply the first priming paint layer on car bodies. A salient feature of the electrocoating process is that the deposited paint layer is highly resistive. Due to this feature, it is possible to achieve fairly uniform paint layers, even for complex body shapes, since the local deposition rate decreases with increasing paint thickness.

This example models electrocoating of a car door where the electrolyte is a dispersion of colloidal paint particles and the paint particles are deposited on the cathode surface.

## Model Definition

---

Figure 1 shows the model geometry. The geometry consists of one single electrolyte domain, with the electrodes being represented as boundaries. The quarter and semi-cylinder surfaces represent the anodes. The car door cathode is completely immersed in the electrolyte.

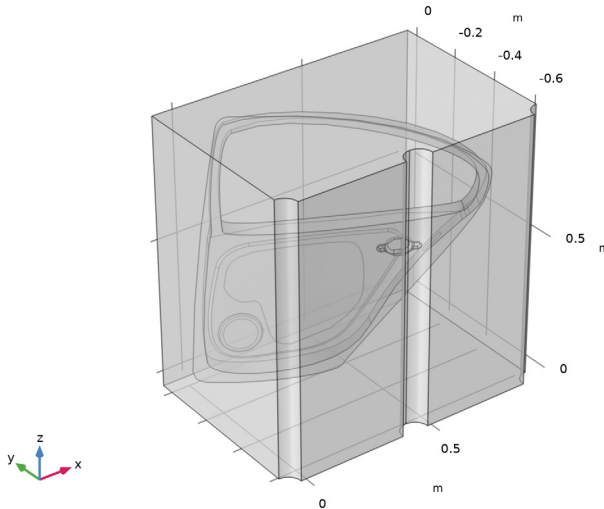

Figure 1: Model geometry. Car door (cathode) and three cylindrical anodes.

The car door geometry used in the model is a surface geometry (that is, a geometry with zero through-plane thickness), and the car door electrode surface is modeled using the Thin Electrode Surface node (see below).

### ELECTROLYTE CHARGE TRANSPORT

Ohm's law is used in the electrolyte domain:

$$\begin{aligned}\mathbf{i}_l &= -\sigma_l \nabla \phi_l \\ \nabla \cdot \mathbf{i}_l &= 0\end{aligned}$$

where  $\phi_l$  (V) is the electrolyte potential,  $\mathbf{i}_l$  is the electrolyte current density vector ( $\text{A}/\text{m}^2$ ) and  $\sigma_l$  (S/m) is the electrolyte conductivity. A uniform composition of the electrolyte is assumed, with an electrolyte conductivity of 0.28 S/m.

### ELECTRODE REACTIONS

The applied cell voltage results in water electrolysis. Oxygen is evolved on the anodes according to



The equilibrium potential,  $E_{\text{eq},\text{O}_2}$  (V), for this reaction is 1.23 V versus SHE.

On the cathodes, hydrogen is evolved according to

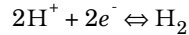

The equilibrium voltage for this reaction is  $E_{\text{eq},\text{H}_2} = 0$  V versus SHE.

Activation overpotentials are assumed to be negligible at both electrodes. The electrode kinetics expression of type Primary condition (thermodynamic equilibrium) is used in the model, to implement that assumption.

### FILM THICKNESS AND RESISTANCE

The consumption of protons at the cathode results in a locally increased pH. This in turn results in reduced solubility and deposition rate of the colloidal paint particles on the electrode. This model assumes a linear relation between the paint film formation rate and the local current density:

$$\frac{ds_i}{dt} = -\frac{i_{\text{loc},i} C_{\text{cap}}}{\rho}$$

where  $s$  (m) is the thickness of the film,  $C_{\text{cap}}$  (kg/C) is the coulombic efficiency of the paint process and  $\rho$  (kg/m<sup>3</sup>) the density of the film. The index  $i$  represents the upside and downside of the cathode surface.  $C_{\text{cap}}$  is a lumped empirical parameter that needs to be measured for each processing bath. In the present model, a value of 60 g/C is used.

The depositing film results in a lowered electrolyte conductivity at the cathode. This is incorporated in the model by adding a potential drop at the cathode according to:

$$\Delta\phi_{\text{film},i} = s_i R_{\text{film}} i_{\text{loc},i}$$

where  $R_{\text{film}}$  ( $\Omega\cdot\text{m}$ ) is the film resistivity, set to 5 M $\Omega\cdot\text{m}$  in this model.

### **ELECTRODE BOUNDARY CONDITIONS**

The cathode is grounded in the model. The following condition is used for the electrolyte potential at the car door cathode boundary

$$\phi_{l,i} = -(E_{\text{eq, H}_2} + \Delta\phi_{\text{film},i})$$

For the anodes the electrolyte voltage is set to

$$\phi_l = E_{\text{cell}} - E_{\text{eq, O}_2}$$

where  $E_{\text{cell}}$  (250 V) is the cell potential. The potential drop due to the ion-exchange membrane that covers the membrane-electrode anode cells is not included in the model.

The local current density of the charge transfer reactions,  $i_{\text{loc}}$  (A/m<sup>2</sup>), which is used in the film thickness and resistance equations, is evaluated such that the above electrolyte potential conditions are satisfied at the cathode and anode boundaries, respectively.

All other surfaces use insulating boundary conditions.

### **REGARDING THE USAGE OF THE THIN ELECTRODE SURFACE NODE**

The Thin Electrode Surface node is used to model the car door cathode surface in this tutorial. The Thin Electrode Surface node introduces “slitting” of the electrolyte potential and surface concentration dependent variables on the interior boundary, which means that they have different values on each side of the car door boundary. Alternatively, one could have modeled the car door geometry with a nonzero thickness in the geometry, removed the volume occupied by the car door domain from the physics selection, and used the Electrode Surface node on the resulting car door external boundaries. However, that approach would have resulted in far more mesh elements and a longer computation time.

## Results and Discussion

Figure 2 shows the paint thickness at the upside of the door after 120 s. The layer is around  $21\ \mu\text{m}$  thick. The thickness variation is less than 5%.

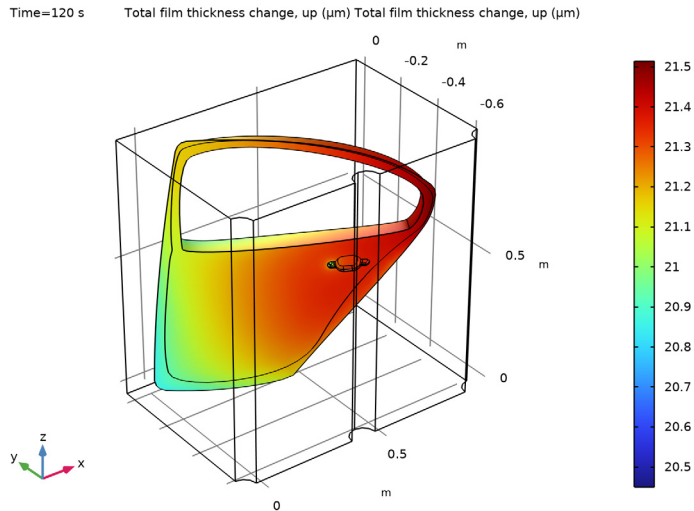
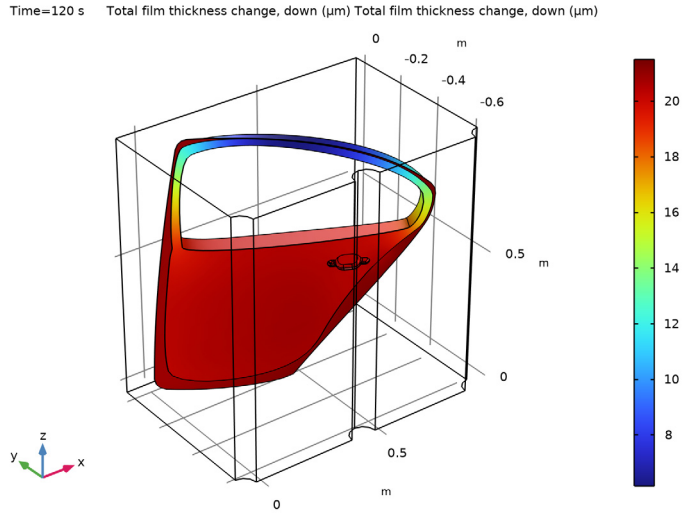

Figure 2: Paint thickness at the upside of the car door after 120 s.

Figure 3 shows the paint thickness after 120 s on the downside of the door. Here the thickness variation is significant. Inside the window frame, the lowest thickness of  $6.2\ \mu\text{m}$  is much lower than on the more exposed parts, which have thicknesses close to  $21\ \mu\text{m}$ .



*Figure 3: Paint thickness at the inside of the car door after 120 s.*

Finally, [Figure 4](#) shows a thickness versus time comparison between the upside and downside of the window frame at a particular point.

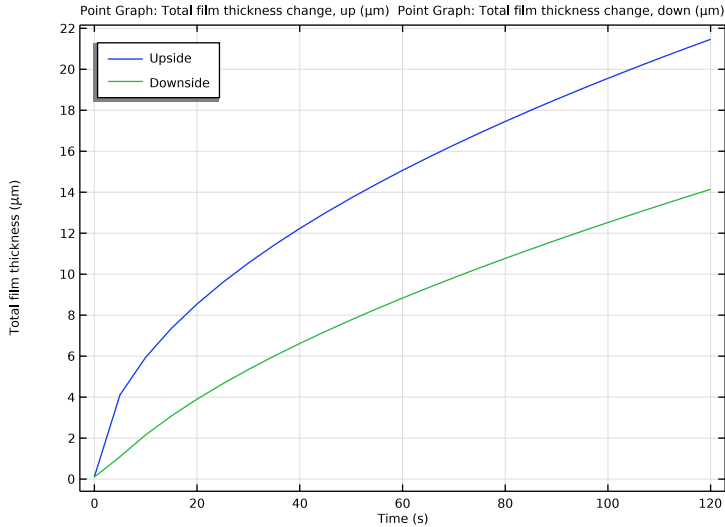

*Figure 4: Paint thickness comparison between the upside and downside of the window frame at a particular point.*

A more elaborate model would include a more detailed description of the electrode reaction activation overpotentials. A further modification would be the inclusion of the transport of paint particles in the electrolyte solution and the paint deposition rate dependence on the local chemistry. Including these modifications would yield a Tertiary Current Distribution model.

### *Reference*

I. F. Hess and U. Gonzalez, “Automotive E-Coat Paint Process Simulation Using FEA,” paper presented at the NAFEMS Ninth International Conference in Orlando, Florida, USA. May 29 2003.

---

**Application Library path:** Electrodeposition\_Module/Tutorials/car\_door

---



### *Modeling Instructions*

From the **File** menu, choose **New**.

## NEW

In the **New** window, click  **Model Wizard**.

## MODEL WIZARD

- 1 In the **Model Wizard** window, click  **3D**.
- 2 In the **Select Physics** tree, select **Electrochemistry** > **Primary and Secondary Current Distribution** > **Primary Current Distribution (cd)**.
- 3 Click **Add**.
- 4 Click  **Study**.
- 5 In the **Select Study** tree, select **General Studies** > **Time Dependent**.
- 6 Click  **Done**.

## GEOMETRY I

The geometry sequence for this model takes some time to set up. To skip these steps you can instead import the geometry sequence from the saved model file in the application library.

To skip setting up the geometry sequence manually: Right click the **Geometry** node and choose **Insert Sequence**. Then choose the Electrodeposition\_Module -> Tutorials -> car\_door.mph file from the application library.

### *Import I (impl)*

If you inserted the whole geometry sequence you can now move on directly to the Global Definitions section below. Otherwise start setting up the geometry by importing the car\_door\_geom.mphbin CAD file as follows:

- 1 In the **Geometry** toolbar, click  **Import**.
- 2 In the **Settings** window for **Import**, locate the **Source** section.
- 3 Click  **Browse**.
- 4 Browse to the model's Application Libraries folder and double-click the file car\_door.mphbin.
- 5 Click  **Import**.

### *Block I (blk I)*

- 1 In the **Geometry** toolbar, click  **Block**.
- 2 In the **Settings** window for **Block**, locate the **Size and Shape** section.
- 3 In the **Height** text field, type 0.7.
- 4 Locate the **Position** section. In the **x** text field, type -0.1.

5 In the **y** text field, type -0.03.

6 Click  **Build Selected**.

#### *Cylinder 1 (cyl1)*

1 In the **Geometry** toolbar, click  **Cylinder**.

2 In the **Settings** window for **Cylinder**, locate the **Size and Shape** section.

3 In the **Radius** text field, type 0.05.

4 Locate the **Position** section. In the **x** text field, type -0.1.

5 In the **y** text field, type -0.03.

6 In the **z** text field, type 0.7.

7 Locate the **Axis** section. From the **Axis type** list, choose **y-axis**.

8 Click  **Build Selected**.

#### *Array 1 (arr1)*

1 In the **Geometry** toolbar, click  **Transforms** and choose **Array**.

2 Select the object **cyl1** only.

3 In the **Settings** window for **Array**, locate the **Size** section.

4 In the **x size** text field, type 3.

5 Locate the **Displacement** section. In the **x** text field, type 0.5.

6 Click  **Build Selected**.

#### *Union 1 (uni1)*

1 In the **Geometry** toolbar, click  **Booleans and Partitions** and choose **Union**.

2 Select the objects **arr1(1,1,1)**, **arr1(2,1,1)**, **arr1(3,1,1)**, and **blk1** only.

3 In the **Settings** window for **Union**, click  **Build Selected**.

#### *Delete Entities 1 (dell)*

1 In the **Model Builder** window, right-click **Geometry 1** and choose **Delete Entities**.

2 In the **Settings** window for **Delete Entities**, locate the **Entities or Objects to Delete** section.

3 From the **Geometric entity level** list, choose **Domain**.

4 On the object **uni1**, select Domains 1 and 3–7 only.



5 Click  **Build Selected**.

#### *Rotate 1 (rot1)*

1 In the **Geometry** toolbar, click  **Transforms** and choose **Rotate**.

- 2 Click in the **Graphics** window and then press Ctrl+A to select all objects.
- 3 In the **Settings** window for **Rotate**, locate the **Rotation** section.
- 4 In the **Angle** text field, type 90.
- 5 From the **Axis type** list, choose **x-axis**.

*Form Union (fin)*

- 1 In the **Model Builder** window, click **Form Union (fin)**.
- 2 In the **Settings** window for **Form Union/Assembly**, locate the **Form Union/Assembly** section.
- 3 From the **Repair tolerance** list, choose **Relative**.
- 4 In the **Geometry** toolbar, click  **Build All**.
- 5 Click the  **Zoom Extents** button in the **Graphics** toolbar.
- 6 Click the  **Transparency** button in the **Graphics** toolbar.

Your finished geometry should now look like this:

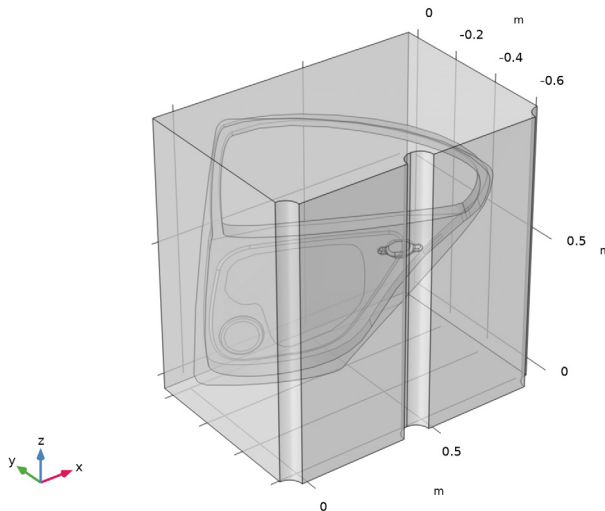

Disable the analysis of the geometry as the remaining small geometric details can be kept.

- 7 In the **Model Builder** window, click **Geometry 1**.
- 8 In the **Settings** window for **Geometry**, locate the **Cleanup** section.
- 9 Clear the **Automatic detection of small details** checkbox.
- 10 In the **Geometry** toolbar, click  **Build All**.

## GLOBAL DEFINITIONS

*Note: Start from this point if you chose to import the geometry sequence..*

Load some model parameters from a text file.

*Parameters 1*

- 1 In the **Model Builder** window, under **Global Definitions** click **Parameters 1**.
- 2 In the **Settings** window for **Parameters**, locate the **Parameters** section.
- 3 Click  **Load from File**.
- 4 Browse to the model's Application Libraries folder and double-click the file `car_door_parameters.txt`.

## DEFINITIONS

Add some selections to the model.

*Anodes*

- 1 In the **Definitions** toolbar, click  **Explicit**.
- 2 In the **Settings** window for **Explicit**, locate the **Input Entities** section.
- 3 From the **Geometric entity level** list, choose **Boundary**.
- 4 Select Boundaries 2, 33, 34, and 84 only.
- 5 In the **Label** text field, type Anodes.

*Cathode*

- 1 In the **Definitions** toolbar, click  **Explicit**.
- 2 In the **Settings** window for **Explicit**, locate the **Input Entities** section.
- 3 From the **Geometric entity level** list, choose **Boundary**.
- 4 Select Boundaries 7–26, 29–32, 36–39, 41–77, and 79–83 only. (All boundaries of the car door).
- 5 In the **Label** text field, type Cathode.

## PRIMARY CURRENT DISTRIBUTION (CD)

*Electrolyte 1*

- 1 In the **Model Builder** window, under **Component 1 (comp1) > Primary Current Distribution (cd)** click **Electrolyte 1**.
- 2 In the **Settings** window for **Electrolyte**, locate the **Electrolyte** section.
- 3 From the  $\sigma_1$  list, choose **User defined**. In the associated text field, type **sigma**.

### Electrode Surface 1

Set up the anodes.



- 1 In the **Physics** toolbar, click  **Boundaries** and choose **Electrode Surface**.
- 2 In the **Settings** window for **Electrode Surface**, locate the **Boundary Selection** section.
- 3 From the **Selection** list, choose **Anodes**.
- 4 Locate the **Electrode Phase Potential Condition** section. In the  $\phi_{s,ext}$  text field, type `E_cell`.

### Electrode Reaction 1

- 1 In the **Model Builder** window, click **Electrode Reaction 1**.
- 2 In the **Settings** window for **Electrode Reaction**, locate the **Equilibrium Potential** section.
- 3 In the  $E_{eq}$  text field, type `Eeq_02`.

### Thin Electrode Surface 1

Now set up the cathode, which is the car door in this model.

- 1 In the **Physics** toolbar, click  **Boundaries** and choose **Thin Electrode Surface**.
- 2 In the **Settings** window for **Thin Electrode Surface**, locate the **Boundary Selection** section.
- 3 From the **Selection** list, choose **Cathode**.
- 4 Click to expand the **Dissolving–Depositing Species** section. Click  **Add**.
- 5 In the table, enter the following settings:

Species	Density (kg/m <sup>3</sup> )	Molar mass (kg/mol)
s1	rho	Meff

- 6 Click to expand the **Film Resistance** section. From the **Film resistance** list, choose **Thickness and conductivity**.
- 7 In the  $s_0$  text field, type `0.1 [um]`.
- 8 In the  $\sigma_{film}$  text field, type `1/R_film`.
- 9 From the  $\Delta s$  list, choose **Total film thickness change, up (cd/tesl)**.
- 10 From the  $\Delta s$  list, choose **Total film thickness change, down (cd/tesl)**.
- 11 From the **Boundary condition formulation** list, choose **Current density**.

### Electrode Reaction 1

- 1 In the **Model Builder** window, click **Electrode Reaction 1**.
- 2 In the **Settings** window for **Electrode Reaction**, locate the **Stoichiometric Coefficients** section.

- 3 In the **Stoichiometric coefficients for dissolving–depositing species:** table, enter the following settings:

Species	Stoichiometric coefficient (I)
sl	1

### MESH I

Now set up the mesh.

- 1 In the **Model Builder** window, under **Component 1 (comp1)** click **Mesh 1**.
- 2 In the **Settings** window for **Mesh**, locate the **Physics-Controlled Mesh** section.
- 3 From the **Element size** list, choose **Coarse**.
- 4 Click  **Build All**.

Your finished mesh should now look like this:

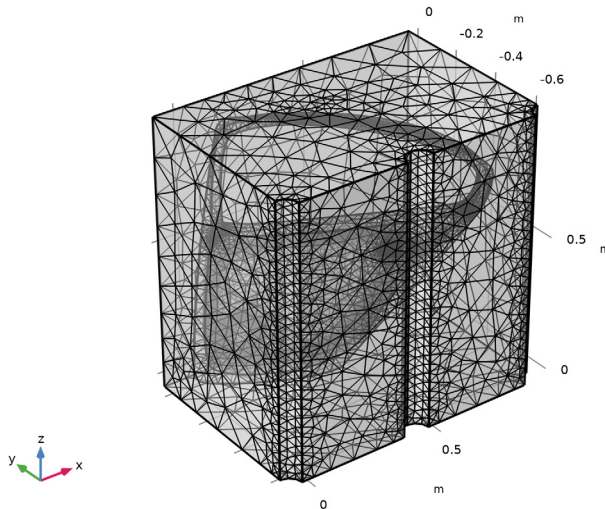

- 5 Click the  **Transparency** button in the **Graphics** toolbar.

### STUDY I

#### Step 1: Time Dependent

The problem is now ready for solving. Set up to the study to simulate the coating process during 2 minutes.

- 1 In the **Model Builder** window, under **Study 1** click **Step 1: Time Dependent**.

- 2 In the **Settings** window for **Time Dependent**, locate the **Study Settings** section.
- 3 In the **Output times** text field, type range (0,5,120).
- 4 In the **Study** toolbar, click  **Compute**.

## RESULTS

A number of plots have been added by default. Now, create separate plots of the electrode potential versus adjacent reference plot for the upside and downside of the car door geometry.

### *Electrode Potential vs. Adjacent Reference, All Electrodes*

- 1 In the **Model Builder** window, under **Results** click **Electrode Potential with Respect to Adjacent Reference (cd)**.
- 2 In the **Settings** window for **3D Plot Group**, type Electrode Potential vs. Adjacent Reference, All Electrodes in the **Label** text field.

### *Electrode Potential vs. Adjacent Reference, Cathode Upside*

- 1 Right-click **Electrode Potential vs. Adjacent Reference, All Electrodes** and choose **Duplicate**.
- 2 In the **Settings** window for **3D Plot Group**, type Electrode Potential vs. Adjacent Reference, Cathode Upside in the **Label** text field.

### *Surface Slit I*

- 1 In the **Model Builder** window, expand the **Electrode Potential vs. Adjacent Reference, Cathode Upside** node, then click **Surface Slit I**.
- 2 In the **Settings** window for **Surface Slit**, locate the **Expression on the Downside** section.
- 3 In the **Expression** text field, type `root.comp1.cd.Evsrefu`.
- 4 Click to expand the **Inherit Style** section. From the **Plot** list, choose **None**.

### *Surface I*

- 1 In the **Model Builder** window, click **Surface I**.
- 2 In the **Settings** window for **Surface**, click to expand the **Inherit Style** section.
- 3 Right-click **Surface I** and choose **Disable**.

### *Electrode Potential vs. Adjacent Reference, Cathode Upside*

- 1 In the **Model Builder** window, click **Electrode Potential vs. Adjacent Reference, Cathode Upside**.
- 2 In the **Electrode Potential vs. Adjacent Reference, Cathode Upside** toolbar, click  **Plot**.

#### *Electrode Potential vs. Adjacent Reference, Cathode Downside*

- 1 Right-click **Electrode Potential vs. Adjacent Reference, Cathode Upside** and choose **Duplicate**.
- 2 In the **Settings** window for **3D Plot Group**, type Electrode Potential vs. Adjacent Reference, Cathode Downside in the **Label** text field.

#### *Surface Slit I*

- 1 In the **Model Builder** window, expand the **Electrode Potential vs. Adjacent Reference, Cathode Downside** node, then click **Surface Slit I**.
- 2 In the **Settings** window for **Surface Slit**, locate the **Expression on the Upside** section.
- 3 In the **Expression** text field, type `root.comp1.cd.Evsrefd`.
- 4 Locate the **Expression on the Downside** section. In the **Expression** text field, type `root.comp1.cd.Evsrefd`.
- 5 In the **Electrode Potential vs. Adjacent Reference, Cathode Downside** toolbar, click  **Plot**.

#### *Total Film Thickness, Cathode*

- 1 In the **Model Builder** window, under **Results** click **Total Electrode Thickness Change (cd)**.
- 2 In the **Settings** window for **3D Plot Group**, type Total Film Thickness, Cathode in the **Label** text field.

The total film thickness at both the sides of the car door was plotted by default. Now create separate upside and downside plots.

#### *Total Film Thickness, Cathode Upside*

- 1 Right-click **Total Film Thickness, Cathode** and choose **Duplicate**.
- 2 In the **Settings** window for **3D Plot Group**, type Total Film Thickness, Cathode Upside in the **Label** text field.

#### *Surface Slit I*

- 1 In the **Model Builder** window, expand the **Total Film Thickness, Cathode Upside** node, then click **Surface Slit I**.
- 2 In the **Settings** window for **Surface Slit**, locate the **Expression on the Downside** section.
- 3 In the **Expression** text field, type `root.comp1.cd.sbtotu`.
- 4 In the **Total Film Thickness, Cathode Upside** toolbar, click  **Plot**.

#### *Total Film Thickness, Cathode Downside*

- 1 In the **Model Builder** window, right-click **Total Film Thickness, Cathode** and choose **Duplicate**.

- 2 In the **Settings** window for **3D Plot Group**, type Total Film Thickness, Cathode Downside in the **Label** text field.

#### *Surface Slit I*

- 1 In the **Model Builder** window, expand the **Total Film Thickness, Cathode Downside** node, then click **Surface Slit I**.
- 2 In the **Settings** window for **Surface Slit**, locate the **Expression on the Upside** section.
- 3 In the **Expression** text field, type `root.comp1.cd.sbtotd`.
- 4 In the **Total Film Thickness, Cathode Downside** toolbar, click  **Plot**.

#### *Total Film Thickness Comparison*

Finally, compare the total upside and downside film thickness at a specific point on the car door geometry.

- 1 In the **Results** toolbar, click  **ID Plot Group**.
- 2 In the **Settings** window for **ID Plot Group**, type Total Film Thickness Comparison in the **Label** text field.
- 3 Locate the **Plot Settings** section.
- 4 Select the **y-axis label** checkbox. In the associated text field, type Total film thickness ( $\mu\text{m}$ ).

#### *Point Graph I*

- 1 In the **Total Film Thickness Comparison** toolbar, click  **Point Graph**.
- 2 Select Point 139 only.
- 3 In the **Settings** window for **Point Graph**, click **Replace Expression** in the upper-right corner of the **y-Axis Data** section. From the menu, choose **Component 1 (comp1) > Primary Current Distribution > Dissolving-depositing species > cd.sbtotu - Total film thickness change, up - m**.
- 4 Click to expand the **Legends** section. Locate the **y-Axis Data** section. From the **Unit** list, choose  $\mu\text{m}$ .
- 5 Locate the **Legends** section. Select the **Show legends** checkbox.
- 6 From the **Legends** list, choose **Manual**.
- 7 In the table, enter the following settings:

<b>Legends</b>
Upside

### *Point Graph 2*

- 1 Right-click **Point Graph 1** and choose **Duplicate**.
- 2 In the **Settings** window for **Point Graph**, locate the **Selection** section.
- 3 Click to select the  **Activate Selection** toggle button.
- 4 Click **Replace Expression** in the upper-right corner of the **y-Axis Data** section. From the menu, choose **Component 1 (comp1) > Primary Current Distribution > Dissolving–depositing species > cd.sbtotd - Total film thickness change, down - m**.
- 5 Locate the **Legends** section. In the table, enter the following settings:

---

#### **Legends**

---



Downside

---

### *Total Film Thickness Comparison*

- 1 In the **Model Builder** window, click **Total Film Thickness Comparison**.
- 2 In the **Settings** window for **ID Plot Group**, locate the **Legend** section.
- 3 From the **Position** list, choose **Upper left**.
- 4 In the **Total Film Thickness Comparison** toolbar, click  **Plot**.

### *Animation 1*

- 1 In the **Results** toolbar, click  **Animation** and choose **File**.
- 2 In the **Settings** window for **Animation**, locate the **Target** section.
- 3 From the **Target** list, choose **Player**.
- 4 Locate the **Scene** section. From the **Subject** list, choose **Total Film Thickness, Cathode Downside**.
- 5 Click the  **Play** button in the **Graphics** toolbar.