



Model created in COMSOL Multiphysics 6.4

# Pitting Corrosion

## *Introduction*

---

Pitting corrosion is a type of localized corrosion by which local cavities, pits, are formed on an initially smooth metal surface. A pit may be initiated due to surface defects, such as inhomogeneities in composition or shape, or mechanical abuse resulting in a small scratch or dent. How and if the pit grows depends on a number of factors such as the type of metal, salinity, pH, and temperature of the aqueous electrolyte. A fundamental understanding of the pitting process is paramount for proper material selection in environments susceptible to this type of corrosion.

This tutorial investigates the fundamental mechanisms of pit propagation by simulating electrode kinetics, mass transfer, and the resulting geometry deformation. In the tutorial, the following overall mechanism for the pitting corrosion is assumed:

Oxygen reduction occurs, mainly outside the pit, on the metal surface



Iron is oxidized, inside and outside the pit, to counterbalance the oxygen reduction reaction



The combination of the two above reactions gives rise to a mixed electrode potential of the metal surface. Since the electrode area inside the pit is small in comparison to the total surface area of the metal, the oxygen-iron mixed potential can be assumed to be constant; that is, to not be affected by the pitting processes.

Dissolved iron then forms iron hydroxide in the electrolyte close to the electrode surface

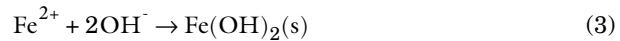

It should be noted that, depending on pH and potentials, other iron containing oxides and hydroxide could also be considered. In this tutorial we will assume a pH ranging from about 10 to 8 in combination with fairly low values for the mixed iron-oxygen potential, which are conditions for which iron hydroxide is the most likely oxidation product.

A result of the iron hydroxide production is that protons are formed by water autoprotolysis to counterbalance the hydroxide ions consumed



Ions such as  $\text{Cl}^-$  may also be transported in order to maintain electroneutrality. The transport of ions, in combination with the pit shape, determine the local pH.

As a result of the consumption of the hydroxide ions in Equation 3, the pH is reduced close to the electrode surface. If the iron oxidation reaction is catalyzed (depassivated) by  $\text{H}^+$ , a lower pH within the pit will result in faster metal dissolution compared to the metal surface outside the pit.

### Model Definition

---

Figure 1 shows the initial model geometry, defining an electrolyte film covering an iron metal electrode surface and an initial pit. The geometry is defined in 2D with axial symmetry.

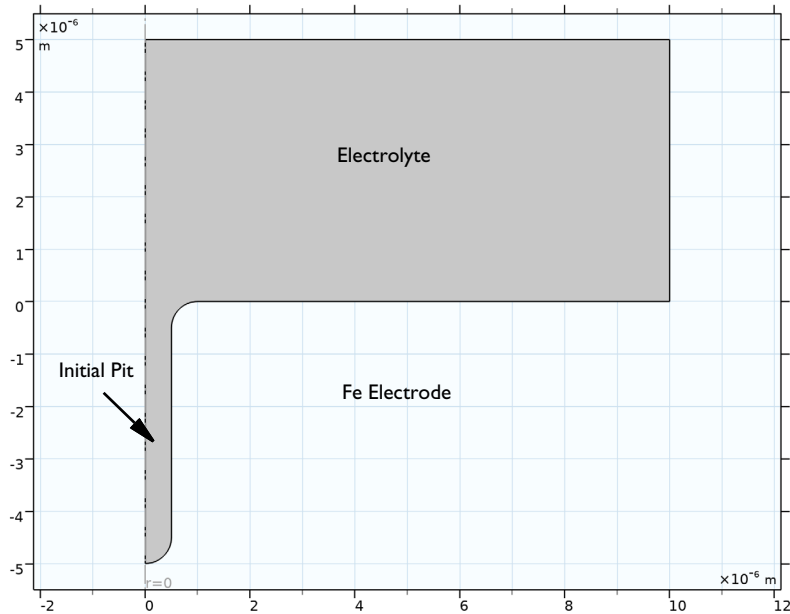

Figure 1: Initial model geometry.

The model is defined using the **Tertiary Current Distribution, Nernst–Planck** interface, solving for the electrolyte phase potential and the concentrations of the electrolyte species  $\text{H}^+$ ,  $\text{OH}^-$ ,  $\text{Cl}^-$ ,  $\text{Na}^+$  and  $\text{Fe}^{2+}$ . The Nernst–Planck equations are used assuming electroneutrality and the water autoprotolysis reaction (Equation 4) to be in equilibrium.

Fixed concentrations and electrolyte phase potential are set at the top horizontal electrolyte boundary facing the bulk of the electrolyte.

Iron dissolves at the electrode surface according to [Equation 2](#), with the kinetics being based on a concentration-dependent Butler–Volmer expression, with the exchange current density set to be proportional to the concentration of  $H^+$ . In this way the iron dissolution reaction gets activated by a lower pH.

The iron metal phase potential is set to a fixed value resulting from the mixed iron-oxygen potential, and as discussed above, this is assumed not to be affected by the local pit corrosion.

The iron hydroxide forming homogeneous reaction ([Equation 3](#)) is assumed to be irreversible.

Due to the formation of iron hydroxide (and other oxidation products), the pit is assumed to be a porous structure with the electrolyte volume fraction in the pit ( $z < 0$ ) fixed to 2.5%. The transport properties (the ion diffusivities and mobilities) depend on the porosity using a Bruggeman relation so that the effective diffusivity in the pit is about  $0,025^{1,5} \approx 0,4\%$  of that of the bulk of the electrolyte.

That the amount of produced  $Fe(OH)_2(s)$  does not affect the porosity is a crude simplification of the processes; a possible extension of the model would be to make porosity a function of  $Fe(OH)_2(s)$  as it forms dynamically over time.

The geometry of the model deforms as a result of the iron dissolution, with the boundary velocity being proportional to the iron dissolution current density.

The model is solved in a time-dependent solver, simulating the propagation of the pit during 30 days.

## *Results and Discussion*

---

[Figure 2](#) shows the iron dissolution current density after 30 days. The current density is larger inside the pit than outside. After 30 days, a pronounced convex-shaped pit has formed below the metal surface.

Time=30 d Streamline: Electrolyte current density vector (spatial and material frames) Surface: abs(tcd.itot) (A/m<sup>2</sup>)

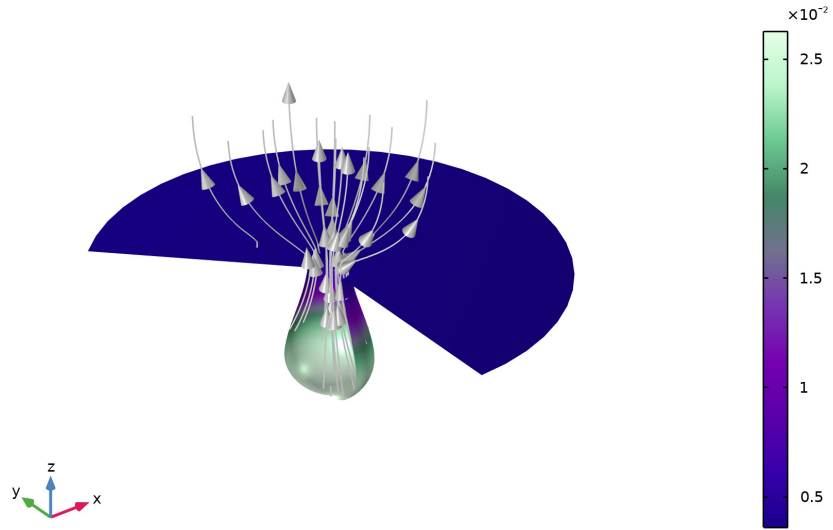

*Figure 2: Iron dissolution current density after 30 days.*

Figure 3 shows the corrosion rate along the electrode surface (one line per day). The corrosion rate within the pit increases with time.

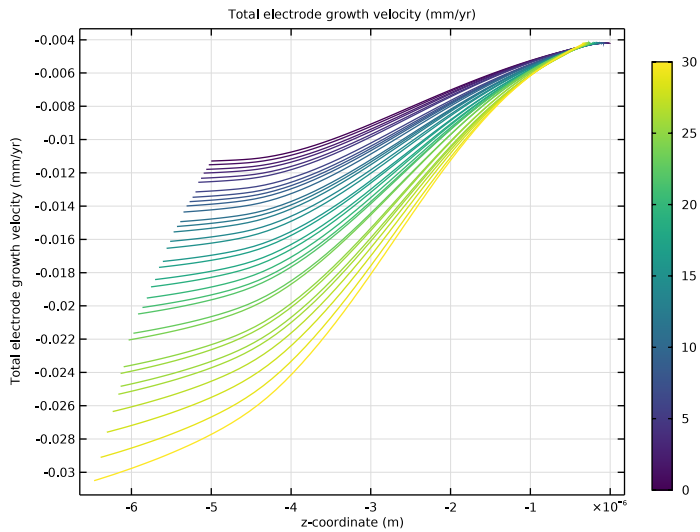

Figure 3: Electrode dissolution rate along the iron electrode surface at various times.

Figure 4 shows the initial pH. For the initial pit shape, the lowest pH is around 9.5 in the pit.

Figure 5 shows the pH at the end of the simulation. The lowest pH is now about 8.7 at the bottom of the pit. The increased pitting rate over time observed in Figure 3 is a result of the lowered pH.

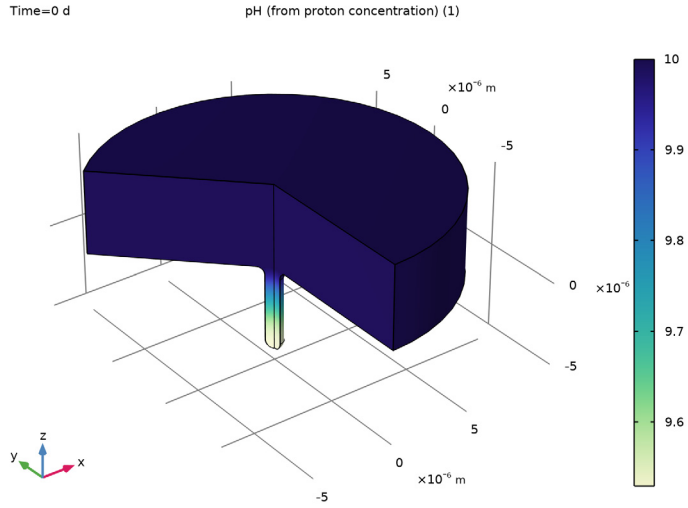

Figure 4: pH in the pit for the initial conditions.

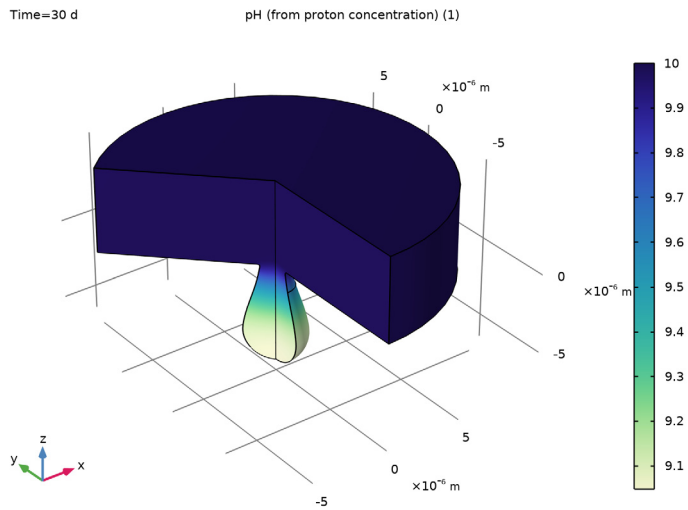

Figure 5: pH of the pit after 30 days.

## Notes About the COMSOL Implementation

---

The **Separator** node is used to define the pit as a porous structure.

Linear elements are used to reduce memory usage and reduce the computation time.

The model is solved in two steps. The first **Stationary** study step solves for the stationary concentration and potential fields for the initial pit shape. The **Time Dependent** study step solves for the pit growth during 30 days, using the stationary solution for initial values.

---

**Application Library path:** Corrosion\_Module/Crevice\_and\_Pitting\_Corrosion/pitting\_corrosion

---

## Modeling Instructions

---

From the **File** menu, choose **New**.

### NEW

In the **New** window, click  **Model Wizard**.

### MODEL WIZARD

- 1 In the **Model Wizard** window, click  **2D Axisymmetric**.
- 2 In the **Select Physics** tree, select **Electrochemistry > Corrosion, Deformed Geometry > Corrosion, Tertiary with Electroneutrality**.
- 3 Click **Add**.
- 4 In the **Number of species** text field, type 3.
- 5 In the **Concentrations (mol/m<sup>3</sup>)** table, enter the following settings:

cNa

cCl

cFe

- 6 Click  **Done**.

### GLOBAL DEFINITIONS



#### Parameters 1

- 1 In the **Model Builder** window, under **Global Definitions** click **Parameters 1**.



- 2 In the **Settings** window for **Parameters**, locate the **Parameters** section.
- 3 Click  **Load from File**.
- 4 Browse to the model's Application Libraries folder and double-click the file `pitting_corrosion_parameters.txt`.

## GEOMETRY I



### *Rectangle 1 (r1)*

- 1 In the **Geometry** toolbar, click  **Rectangle**.
- 2 In the **Settings** window for **Rectangle**, locate the **Size and Shape** section.
- 3 In the **Width** text field, type `R_pit*20`.
- 4 In the **Height** text field, type `R_pit*10`.
- 5 Click  **Build Selected**.
- 6 Click the  **Zoom Extents** button in the **Graphics** toolbar.



### *Rectangle 2 (r2)*

- 1 In the **Geometry** toolbar, click  **Rectangle**.
- 2 In the **Settings** window for **Rectangle**, locate the **Size and Shape** section.
- 3 In the **Width** text field, type `R_pit`.
- 4 In the **Height** text field, type `H_pit`.
- 5 Locate the **Position** section. In the **z** text field, type `-H_pit`.
- 6 Click  **Build Selected**.

### *Union 1 (un1)*

- 1 In the **Geometry** toolbar, click  **Booleans and Partitions** and choose **Union**.
- 2 Click in the **Graphics** window and then press `Ctrl+A` to select both objects.
- 3 In the **Settings** window for **Union**, locate the **Union** section.
- 4 Clear the **Keep interior boundaries** checkbox.
- 5 Click  **Build Selected**.

### *Fillet 1 (fill)*

- 1 In the **Geometry** toolbar, click  **Fillet**.
- 2 Click the  **Zoom Extents** button in the **Graphics** toolbar.
- 3 On the object **un1**, select Points 4 and 5 only.
- 4 In the **Settings** window for **Fillet**, locate the **Radius** section.
- 5 In the **Radius** text field, type `R_pit`.

6 Click  **Build Selected.**

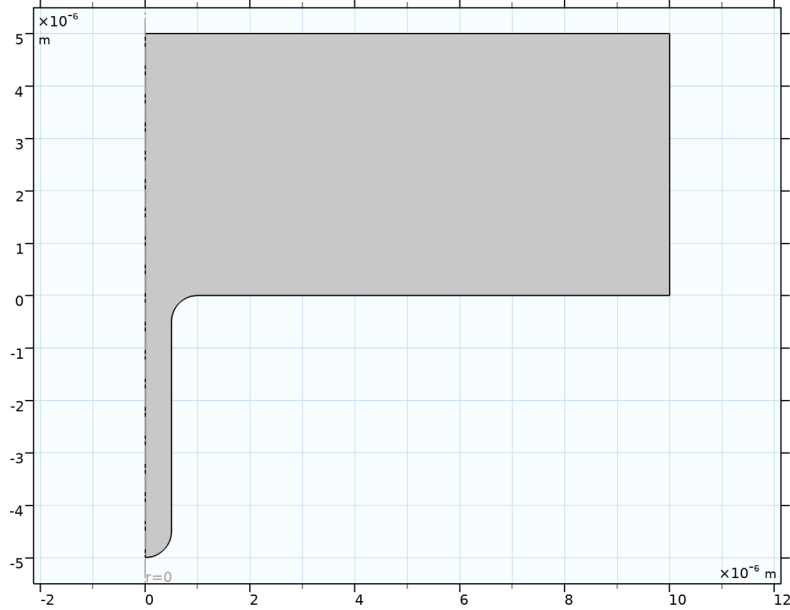

### **TERTIARY CURRENT DISTRIBUTION, NERNST-PLANCK (TCD)**

Change the charge transport model to **Water-based with electroneutrality**. This will add the water auto protolysis as an equilibrium reaction as well as the proton and hydroxide ion concentrations to the equation system, and save for the two concentrations algebraically.

- 1 In the **Model Builder** window, under **Component 1 (comp1)** click **Tertiary Current Distribution, Nernst-Planck (tcd)**.
- 2 In the **Settings** window for **Tertiary Current Distribution, Nernst-Planck**, locate the **Electrolyte Charge Conservation** section.
- 3 From the **Charge conservation model** list, choose **Water-based with electroneutrality**.

### **DEFINITIONS**

#### *Variables 1*

- 1 In the **Model Builder** window, under **Component 1 (comp1)** right-click **Definitions** and choose **Variables**.
- 2 In the **Settings** window for **Variables**, locate the **Variables** section.
- 3 Click  **Load from File**.

- 4 Browse to the model's Application Libraries folder and double-click the file `pitting_corrosion_variables.txt`.

### **TERTIARY CURRENT DISTRIBUTION, NERNST-PLANCK (TCD)**

#### *Species Charges |*

- 1 In the **Model Builder** window, under **Component 1 (comp1) > Tertiary Current Distribution, Nernst-Planck (tcd)** click **Species Charges 1**.
- 2 In the **Settings** window for **Species Charges**, locate the **Charge** section.
- 3 In the  $z_{\text{cNa}}$  text field, type 1.
- 4 In the  $z_{\text{cCl}}$  text field, type -1.
- 5 In the  $z_{\text{cFe}}$  text field, type 2.

The pit is assumed to be porous, with a nonunit volume fraction of electrolyte. The **Separator** node may be used to specify the porosity.

#### *Separator |*

- 1 In the **Physics** toolbar, click  **Domains** and choose **Separator**.
- 2 In the **Settings** window for **Separator**, locate the **Domain Selection** section.
- 3 From the **Selection** list, choose **All domains**.
- 4 Locate the **Diffusion** section. In the  $D_{\text{cNa}}$  text field, type `D_Na`.
- 5 In the  $D_{\text{cCl}}$  text field, type `D_Cl`.
- 6 In the  $D_{\text{cFe}}$  text field, type `D_Fe`.
- 7 In the  $D_{\text{cH}}$  text field, type `D_H`.
- 8 In the  $D_{\text{cOH}}$  text field, type `D_OH`.
- 9 Locate the **Porous Matrix Properties** section. In the  $\epsilon_1$  text field, type `eps1`.

#### *Reactions |*

- 1 In the **Physics** toolbar, click  **Domains** and choose **Reactions**.
- 2 In the **Settings** window for **Reactions**, locate the **Domain Selection** section.
- 3 From the **Selection** list, choose **All domains**.
- 4 Locate the **Reaction Rates** section. In the  $R_{\text{cFe}}$  text field, type `-R_FeOH2`.
- 5 In the  $R_{\text{cOH}}$  text field, type `-2*R_FeOH2`.

Use a **Concentration** and an **Electrolyte Potential** node to define the boundary toward the bulk of the electrolyte, at the top of the geometry.

### Concentration I

- 1 In the **Physics** toolbar, click  **Boundaries** and choose **Concentration**.
- 2 Select Boundary 3 only.
- 3 In the **Settings** window for **Concentration**, locate the **Concentration** section.
- 4 Select the **Species cNa** checkbox.
- 5 In the  $c_{0,cNa}$  text field, type  $cNa\_0$ .
- 6 Select the **Species cCl** checkbox.
- 7 In the  $c_{0,cCl}$  text field, type  $cCl\_0$ .
- 8 Select the **Species cFe** checkbox.
- 9 In the  $c_{0,cFe}$  text field, type  $cFe\_0$ .

### Electrolyte Potential I

- 1 In the **Physics** toolbar, click  **Boundaries** and choose **Electrolyte Potential**.
- 2 Select Boundary 3 only.

### Electrode Surface I

- 1 In the **Physics** toolbar, click  **Boundaries** and choose **Electrode Surface**.
- 2 Select Boundaries 4, 5, 7, and 8 only.
- 3 In the **Settings** window for **Electrode Surface**, click to expand the **Dissolving–Depositing Species** section.
- 4 Click **+ Add**.
- 5 In the table, enter the following settings:

Species	Density (kg/m <sup>3</sup> )	Molar mass (kg/mol)
Fe	rho_Fe	M_Fe

- 6 Clear the **Solve for surface concentration variables** checkbox.
- 7 Locate the **Electrode Phase Potential Condition** section. In the  $\phi_{s,ext}$  text field, type  $E\_metal$ .

### Electrode Reaction I

- 1 In the **Model Builder** window, click **Electrode Reaction 1**.
- 2 In the **Settings** window for **Electrode Reaction**, locate the **Stoichiometric Coefficients** section.
- 3 In the  $n$  text field, type 2.
- 4 In the  $v_{cFe}$  text field, type -1.

- 5 In the **Stoichiometric coefficients for dissolving–depositing species**: table, enter the following settings:

Species	Stoichiometric coefficient (I)
Fe	1

- 6 Locate the **Equilibrium Potential** section. In the  $E_{\text{eq,ref}}(T)$  text field, type Eeq\_Fe.
- 7 Locate the **Electrode Kinetics** section. In the  $i_{0,\text{ref}}(T)$  text field, type i0\_ref\_Fe\* (tcd.cH/cH\_ref).
- 8 In the  $\alpha_a$  text field, type 0.25.

#### *Initial Values I*

- 1 In the **Model Builder** window, under **Component 1 (comp1) > Tertiary Current Distribution, Nernst–Planck (tcd)** click **Initial Values I**.
- 2 In the **Settings** window for **Initial Values**, locate the **Initial Values** section.
- 3 In the  $cNa$  text field, type cNa\_0.
- 4 In the  $cCl$  text field, type cCl\_0.
- 5 In the  $cFe$  text field, type cFe\_0.

### **MULTIPHYSICS**

#### *Nondeforming Boundary I (ndbdg1)*

Switch to zero normal displacement for the nondeforming boundaries. This is a more stable boundary condition for the deformation, but it can only be used for straight boundaries.

- 1 In the **Model Builder** window, under **Component 1 (comp1) > Multiphysics** click **Nondeforming Boundary I (ndbdg1)**.
- 2 In the **Settings** window for **Nondeforming Boundary**, locate the **Nondeforming Boundary** section.
- 3 From the **Boundary condition** list, choose **Zero normal displacement**.

### **TERTIARY CURRENT DISTRIBUTION, NERNST–PLANCK (TCD)**

- 1 In the **Model Builder** window, under **Component 1 (comp1)** click **Tertiary Current Distribution, Nernst–Planck (tcd)**.

**2** In the **Settings** window for **Tertiary Current Distribution, Nernst–Planck**, click to expand the **Discretization** section.

Using linear elements instead of quadratic saves memory and speeds up the computation for this model.

**3** From the **Concentration** list, choose **Linear**.

**4** From the **Electrolyte potential** list, choose **Linear**.

**5** From the **Electric potential** list, choose **Linear**.

## **MESH 1**

**1** In the **Model Builder** window, under **Component 1 (comp1)** click **Mesh 1**.

**2** In the **Settings** window for **Mesh**, locate the **Sequence Type** section.

**3** From the list, choose **User-controlled mesh**.

### *Size 1*

**1** In the **Model Builder** window, right-click **Free Triangular 1** and choose **Size**.

**2** In the **Settings** window for **Size**, locate the **Geometric Entity Selection** section.

**3** From the **Geometric entity level** list, choose **Boundary**.

**4** Select Boundaries 4, 7, and 8 only.

**5** Locate the **Element Size** section. From the **Predefined** list, choose **Extremely fine**.

### *Size 2*

**1** Right-click **Free Triangular 1** and choose **Size**.

**2** In the **Settings** window for **Size**, locate the **Geometric Entity Selection** section.

**3** From the **Geometric entity level** list, choose **Point**.

**4** Select Point 2 only.

**5** Locate the **Element Size** section. From the **Predefined** list, choose **Extremely fine**.

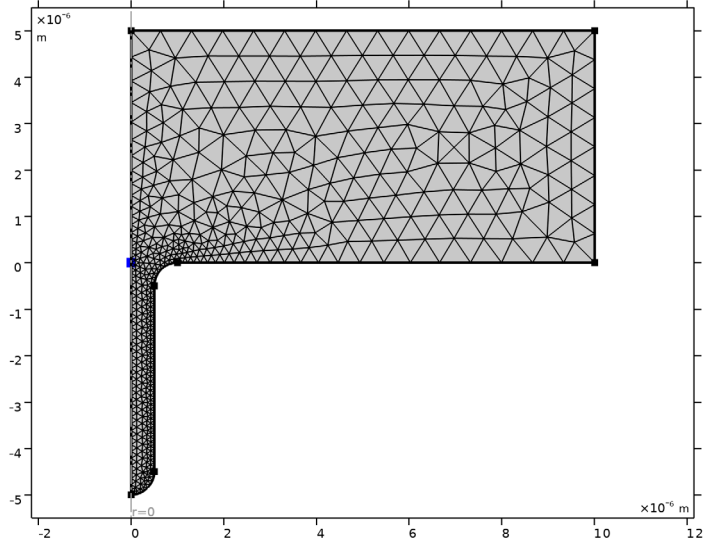

6 Click  **Build All**.



## ROOT

For solving the model we will first compute a stationary current and concentration distribution for this initial shape of the pit. Then we will use this solution as initial values for a 30-day time-dependent simulation.

## ADD STUDY

- 1 In the **Home** toolbar, click  **Add Study** to open the **Add Study** window.
- 2 Go to the **Add Study** window.
- 3 Find the **Studies** subsection. In the **Select Study** tree, select **General Studies** > **Stationary**.
- 4 Right-click and choose **Add Study**.
- 5 In the **Home** toolbar, click  **Add Study** to close the **Add Study** window.



## STUDY I

*Step 1: Stationary*

- 1 In the **Settings** window for **Stationary**, locate the **Physics and Variables Selection** section.
- 2 In the **Solve for** column of the table, under **Component 1 (comp1)**, clear the checkbox for **Deformed Geometry**.

- 3 In the **Solve for** column of the table, under **Component 1 (comp1) > Multiphysics**, clear the checkboxes for **Nondeforming Boundary 1 (ndbdg1)** and **Deforming Electrode Surface 1 (desdg1)**.

#### *Step 2: Time Dependent*

- 1 In the **Study** toolbar, click  **Time Dependent**.
- 2 In the **Settings** window for **Time Dependent**, locate the **Study Settings** section.
- 3 From the **Time unit** list, choose **d**.
- 4 In the **Output times** text field, type range (0,1,30).
- 5 Click to expand the **Study Extensions** section. Use automatic remeshing to stop and remesh the model if the mesh gets too distorted due to the geometry deformation.
- 6 Select the **Automatic remeshing** checkbox.
- 7 In the **Study** toolbar, click  **Compute**.

## **RESULTS**

#### *Electrolyte Current Density, 3D (tcd)*

- 1 In the **Model Builder** window, expand the **Results > Electrolyte Current Density, 3D (tcd)** node, then click **Electrolyte Current Density, 3D (tcd)**.
- 2 In the **Settings** window for **3D Plot Group**, locate the **Plot Settings** section.
- 3 Clear the **Plot dataset edges** checkbox.

#### *Streamline 1*

- 1 In the **Model Builder** window, click **Streamline 1**.
- 2 In the **Settings** window for **Streamline**, locate the **Coloring and Style** section.
- 3 Find the **Point style** subsection. From the **Arrow length** list, choose **Normalized**.

#### *Color Expression 1*

- 1 In the **Model Builder** window, expand the **Streamline 1** node.
- 2 Right-click **Color Expression 1** and choose **Disable**.

#### *Surface 1*

- 1 In the **Model Builder** window, under **Results > Electrolyte Current Density, 3D (tcd)** click **Surface 1**.
- 2 In the **Settings** window for **Surface**, locate the **Coloring and Style** section.
- 3 From the **Color table** list, choose **AuroraBorealis**.
- 4 From the **Color table transformation** list, choose **Reverse**.

5 Click the  **Show Grid** button in the **Graphics** toolbar.

6 In the **Electrolyte Current Density, 3D (tcd)** toolbar, click  **Plot**.

Time=30 d Streamline: Electrolyte current density vector (spatial and material frames) Surface: abs(tcd.itot)  
(A/m<sup>2</sup>)

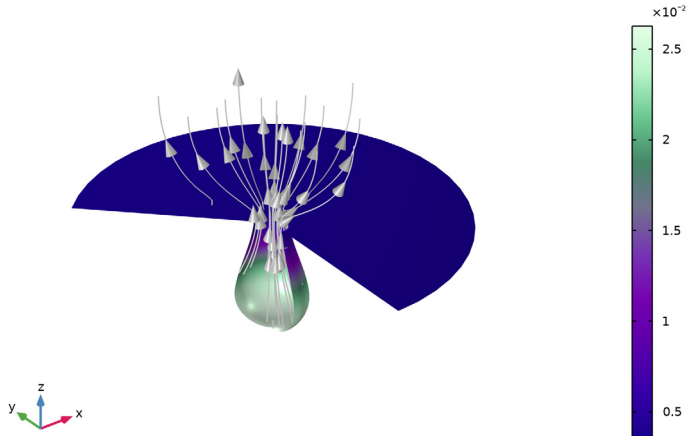

7 Click the  **Zoom Extents** button in the **Graphics** toolbar.

*pH*

1 In the **Results** toolbar, click  **2D Plot Group**.

2 In the **Settings** window for **2D Plot Group**, type pH in the **Label** text field.

3 Locate the **Data** section. From the **Dataset** list, choose **Study 1/ Remeshed Solution 1 (sol3)**.

4 From the **Time (d)** list, choose **0**.

*Surface 1*

1 Right-click **pH** and choose **Surface**.

2 In the **Settings** window for **Surface**, locate the **Expression** section.

3 In the **Expression** text field, type `tcd.pH`.

4 Locate the **Coloring and Style** section. From the **Color table** list, choose **Cyanthus**.

5 In the **pH** toolbar, click  **Plot**.

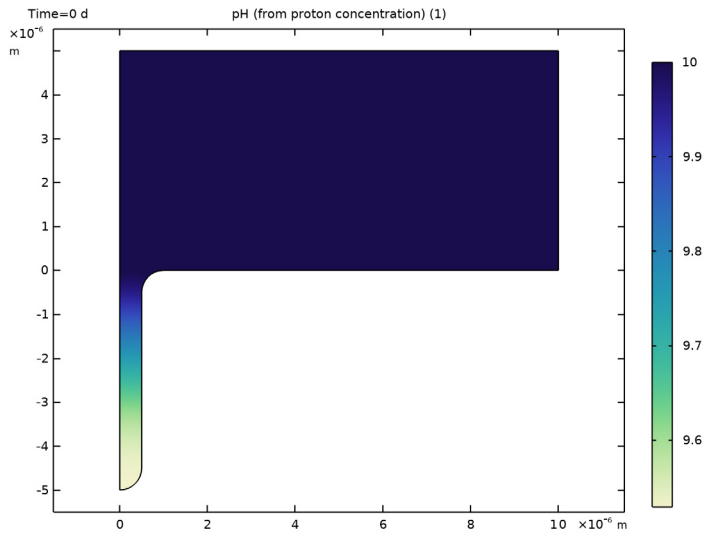

### *pH, 3D*

- 1 In the **Results** toolbar, click  **3D Plot Group**.
- 2 In the **Settings** window for **3D Plot Group**, type pH, 3D in the **Label** text field.

### *Surface 1*

- 1 Right-click **pH, 3D** and choose **Surface**.
- 2 In the **Settings** window for **Surface**, locate the **Expression** section.
- 3 In the **Expression** text field, type `tcd.pH`.
- 4 Locate the **Coloring and Style** section. From the **Color table** list, choose **Cyanthus**.

### *pH, 3D*

- 1 Click the  **Show Grid** button in the **Graphics** toolbar.
- 2 In the **Model Builder** window, click **pH, 3D**.

- 3 In the **pH, 3D** toolbar, click  **Plot**.

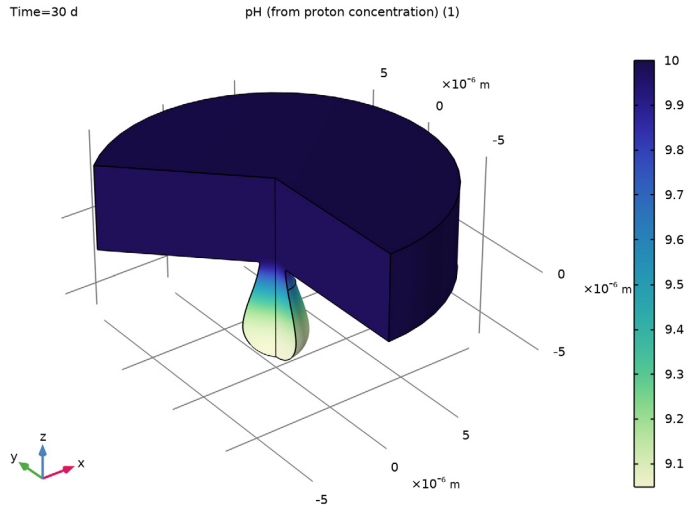

#### Corrosion rate

- 1 In the **Results** toolbar, click  **ID Plot Group**.
- 2 In the **Settings** window for **ID Plot Group**, type **Corrosion rate** in the **Label** text field.
- 3 Locate the **Data** section. From the **Dataset** list, choose **Study 1/ Remeshed Solution 1 (sol3)**.

#### Line Graph 1

- 1 Right-click **Corrosion rate** and choose **Line Graph**.
- 2 Select **Boundaries 4, 5, 7, and 8** only.
- 3 In the **Settings** window for **Line Graph**, click **Replace Expression** in the upper-right corner of the **y-Axis Data** section. From the menu, choose **Component 1 (comp1) > Tertiary Current Distribution, Nernst-Planck > Dissolving-depositing species > tcd.vbtot - Total electrode growth velocity - m/s**.
- 4 Locate the **y-Axis Data** section. From the **Unit** list, choose **mm/yr**.
- 5 Locate the **x-Axis Data** section. From the **Parameter** list, choose **Expression**.
- 6 In the **Expression** text field, type **z**.



#### Color Expression 1

- 1 Right-click **Line Graph 1** and choose **Color Expression**.
- 2 In the **Settings** window for **Color Expression**, locate the **Coloring and Style** section.

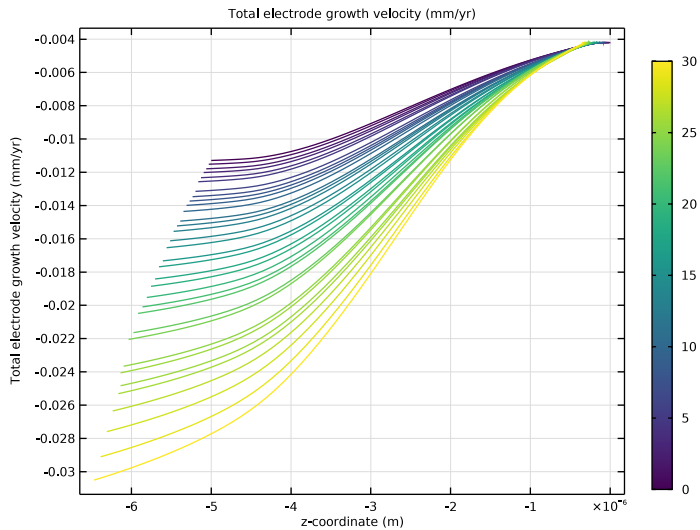
- 3 From the **Color table** list, choose **Viridis**.
- 4 Locate the **Expression** section. In the **Expression** text field, type  $t$ .
- 5 From the **Unit** list, choose **d**.
- 6 In the **Corrosion rate** toolbar, click  **Plot**.



#### Animation 1

- 1 In the **Results** toolbar, click  **Animation** and choose **Player**.
- 2 In the **Settings** window for **Animation**, locate the **Scene** section.
- 3 From the **Subject** list, choose **pH**.
- 4 Locate the **Frames** section. From the **Frame selection** list, choose **All**.
- 5 Click the  **Play** button in the **Graphics** toolbar.