



Model created in COMSOL Multiphysics 6.4

# Stress and Modal Analysis of a Wind Turbine Composite Blade

## Introduction

---

Wind turbines are an increasingly popular source of renewable energy. As such, the design, analysis and manufacture of wind turbines are important to the energy industry.

The turbine blades are critical components of a wind turbine. When generating electric power through rotation, they have to withstand different types of loads, such as wind, gravitational, and centrifugal loads. The sheer size of a blade necessitates light and strong materials, and composites are well suited for this.

This example shows how to analyze a composite wind turbine blade using a mixture of carbon–epoxy, glass–vinylester and PVC foam. The blade is constructed as a sandwich structure where the PVC foam core is sandwiched between carbon–epoxy and glass–vinylester.

First, a stress analysis of the blade is performed in which it is subjected to a combination of gravitational and centrifugal loads. The tip displacement, maximum stress values, and through-thickness stress distribution at a particular point on the blade are computed for different load cases. Second, a prestressed eigenfrequency analysis is performed for a range of operating speeds. A Campbell diagram depicting the variation of eigenfrequencies with rotation speed is generated.



Read more about the Composite Materials Module and the analysis of composite wind turbine blade in the following COMSOL blogs:

- [Introduction to the Composite Materials Module.](#)
  - [Analyzing Wind Turbine Blades with the Composite Material Module.](#)
- 

## Model Definition

---

The geometry consists of a wind turbine blade of 61.5 m length as shown in [Figure 1](#). This is a blade geometry used in the NREL 5MW wind turbine ([Ref. 1](#) and [Ref. 2](#)). The front and top views of the geometry are shown in [Figure 2](#).

The blade geometry has 19 different sections, where each section is defined by an airfoil shape. The details of the type of airfoil together with the maximum chord and the twist in each section is given in [Table 1](#).

Essentially there are six different types of airfoils which are used to build the full wind turbine blade as shown in [Figure 3](#). Note that the NACA 64-618 is the best airfoil from aerodynamic point of view and hence used near the tip region whereas the DU 99-W-405

is good from a structural point of view and hence used near the root of the blade. In between there are other airfoils of DU family which are used for smooth transition between the two extreme airfoil shapes. More details about the DU family airfoils can be found in [Ref. 3](#).

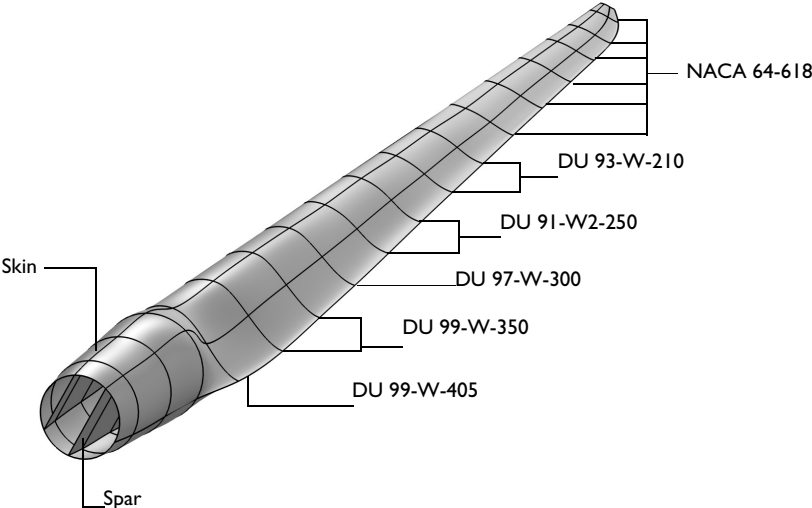

*Figure 1: Geometry of a wind turbine blade for the NREL 5MW wind turbine. The different airfoils used at various sections are also shown.*

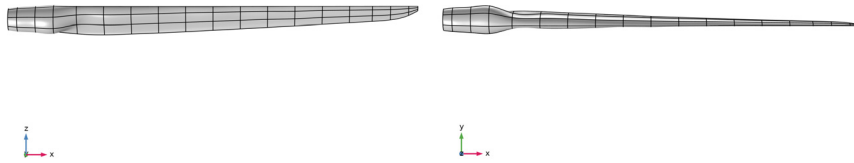

Figure 2: Front view ( $zx$ -plane) and top view ( $xy$ -plane) of the wind turbine blade.

TABLE I: DIRECTIONAL INFORMATION OF WIND TURBINE BLADE GEOMETRY.

No	Blade span (m)	Chord (m)	Twist (deg)	Airfoil
1	0	3.2	13.08	Circular airfoil
2	1.36	3.54	13.08	Circular airfoil
3	4.1	3.85	13.08	Circular airfoil
4	6.83	4.167	13.08	Circular airfoil
5	10.25	4.55	13.08	DU 99-W-405
6	14.35	4.652	11.48	DU 99-W-350
7	18.45	4.458	10.16	DU 99-W-350
8	22.55	4.249	9.011	DU 97-W-300
9	26.65	4.007	7.795	DU 91-W2-250
10	30.75	3.748	6.544	DU 91-W2-250
11	34.85	3.502	5.361	DU 93-W-210
12	38.95	3.256	4.188	DU 93-W-210
13	43.05	3.01	3.125	NACA 64-618
14	47.15	2.764	2.319	NACA 64-618
15	51.25	2.518	1.526	NACA 64-618
16	54.67	2.313	0.863	NACA 64-618
17	57.4	2.086	0.37	NACA 64-618
18	60.13	1.4	0.16	NACA 64-618
19	61.5	0.7	0	NACA 64-618

There are two important parts of a wind turbine blade:

- Skin
- Spars

The skin consists of the outer curved boundaries. It carries essentially the entire loading. In order to increase bending and torsional stiffness, the blade is reinforced using spars, which are internal vertical members.

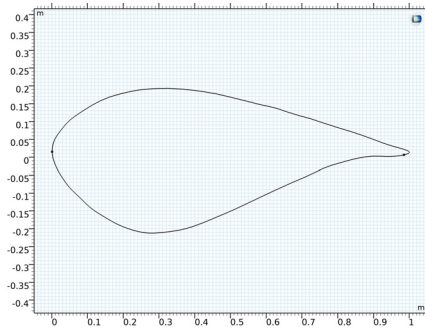

DU 99-W-405

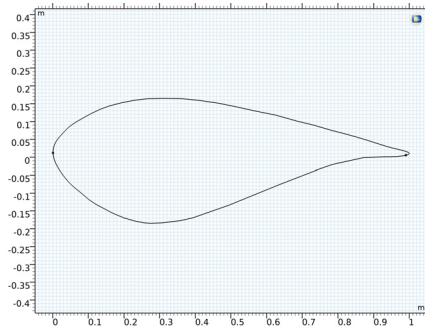

DU 99-W-350

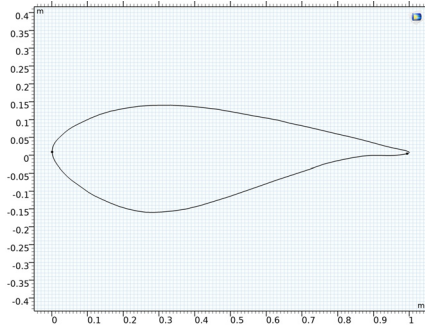

DU 97-W-300

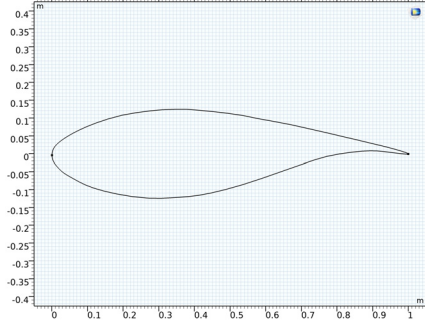

DU 91-W2-250

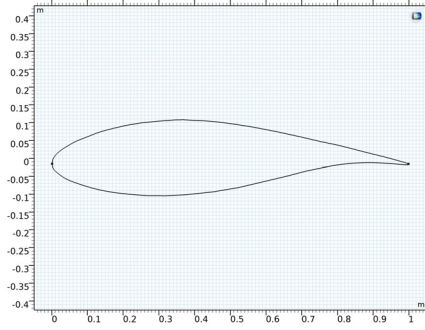

DU 93-W-210

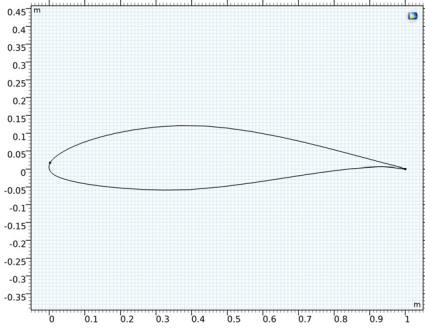

NACA 64-618

Figure 3: Different types of airfoils used at various sections of the wind turbine blade.

## LOADS AND BOUNDARY CONDITIONS

The left end of the blade is connected to the rotor hub, and it is fixed, as shown in [Figure 4](#). The loads acting on the structure are the self-weight of the blade and the centrifugal force. The aerodynamic or wind loads are not considered.

Two types of analyses are performed:

- A Stationary analysis: This analysis is performed for the gravity load case, centrifugal force load case, and a combination of the gravity and centrifugal force load cases, for a single blade-RPM value (15 rpm).
- A Prestressed Eigenfrequency analysis: This analysis is performed for centrifugal load case for a range of blade RPMs (0–30 rpm).

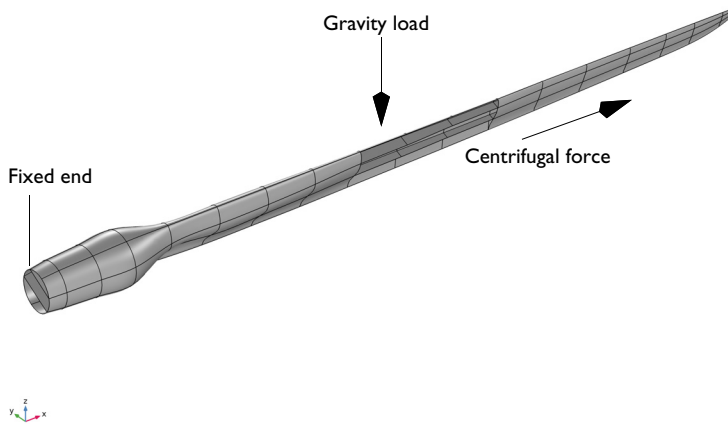

*Figure 4: The geometry showing boundary conditions and loads acting on the structure.*

## LAMINA MATERIAL PROPERTIES

The analyzed wind turbine blade is a sandwich structure consisting of three different layered material types as shown in [Figure 5](#).

The material properties of different laminae is taken from [Ref. 4](#).

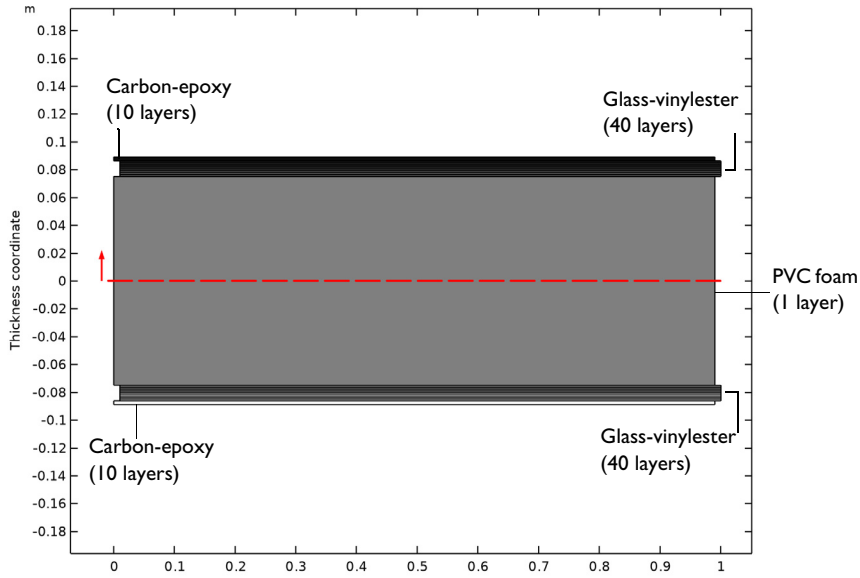

Figure 5: Sandwich arrangement of different layered materials used in the skin as well as in the spar of the blade.

#### Carbon-Epoxy Laminate

The outer part of the sandwich structure is a carbon-epoxy laminate having 10 layers, each of thickness 0.28 mm and oriented at 0 degrees to the first axis of the laminate coordinate system. The density of the lamina is taken as  $1560 \text{ kg/m}^3$ . The transversely isotropic material properties of the lamina are given in Table 2.

TABLE 2: MATERIAL PROPERTIES OF CARBON-EPOXY MATERIAL.

Material Property	Value
$\{E_{11}, E_{22}\}$	$\{139, 9\}$ (GPa)
$G_{12}$	5.5 (GPa)
$\{\nu_{12}, \nu_{23}\}$	$\{0.32, 0.32\}$

### *Glass-Vinylester Laminate*

The next part of the sandwich structure is a glass-vinylester laminate. The density of this lamina is taken as  $1890 \text{ kg/m}^3$ . The transversely isotropic material properties are given in [Table 3](#).

TABLE 3: MATERIAL PROPERTIES OF GLASS-VINYLESTER MATERIAL.

Material Property	Value
$\{E_{11}, E_{22}\}$	$\{41, 9\}$ (GPa)
$G_{12}$	4.1 (GPa)
$\{\nu_{12}, \nu_{23}\}$	$\{0.3, 0.3\}$

This laminate is made of 40 layers, each of 0.28 mm thickness with the stacking sequence shown in [Table 4](#) and [Figure 6](#).

TABLE 4: FIBER ORIENTATION IN GLASS-VINYLESTER LAYERED MATERIAL.

Layer Number	Fiber Orientation
1 - 5	0
6 - 10	45
11 - 15	-45
16 - 20	90
21 - 25	90
26 - 30	-45
31 - 35	45
36 - 40	0

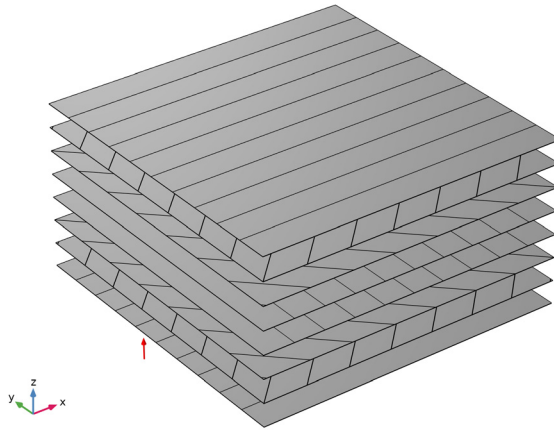

*Figure 6: Stacking sequence of the glass–vinylester laminate, showing the fiber orientation in each layer, from bottom to top.*

#### *PVC Foam*

The core material of the sandwich structure is made of PVC Foam of thickness 15 cm. The density of the material is taken as  $200 \text{ kg/m}^3$ . The values of Young’s modulus, shear modulus and Poisson’s ratio for the material are taken as 250 MPa, 92.6 MPa, and 0.35, respectively.

#### **LAMINATE COORDINATE SYSTEM**

The orientation of the laminate coordinate system in which the laminate material properties are specified is shown in [Figure 7](#).

Load case: Gravity+Centrifugal Force Thickness and Orientation (shell)

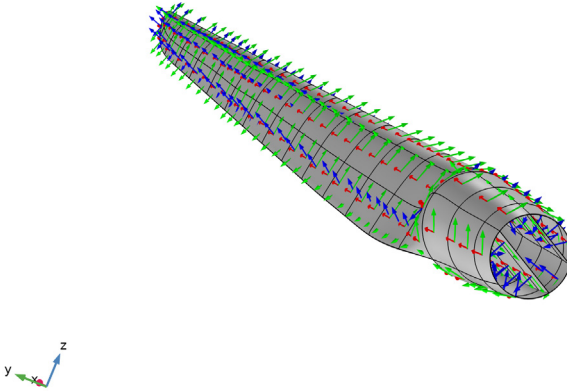

*Figure 7: The laminate coordinate system used to define material properties in the wind turbine blade.*

#### **FINITE ELEMENT MESH**

The structure is discretized using a mapped mesh, as shown in [Figure 8](#).

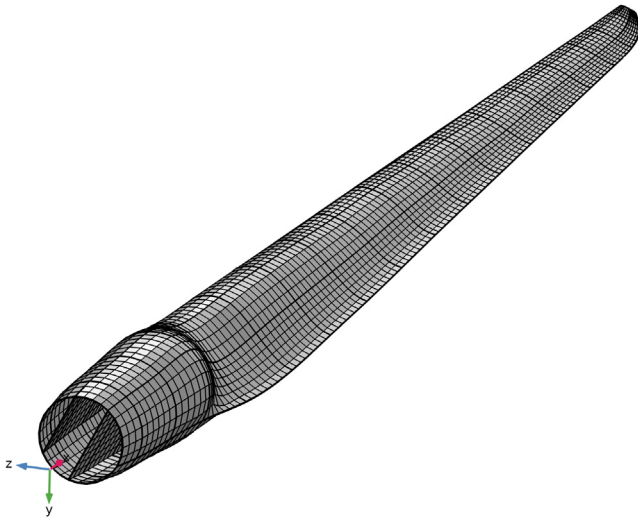

*Figure 8: The mapped mesh for the wind turbine blade.*

## Results and Discussion

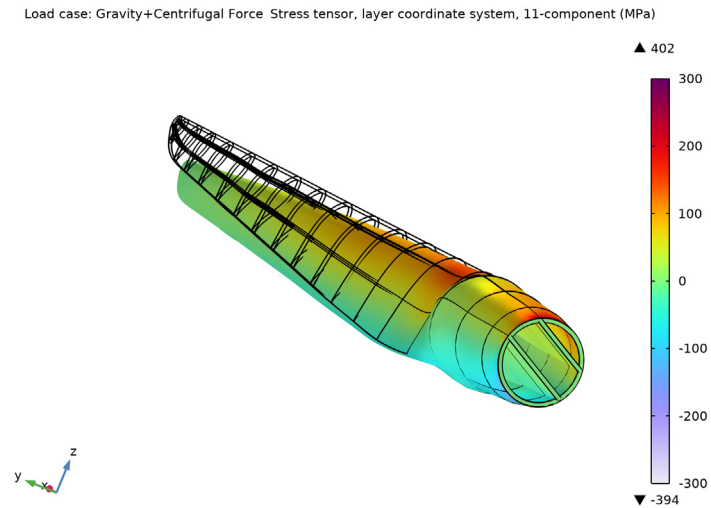

Figure 9: The stress distribution in the skin and spar for combined gravitational and centrifugal loads.

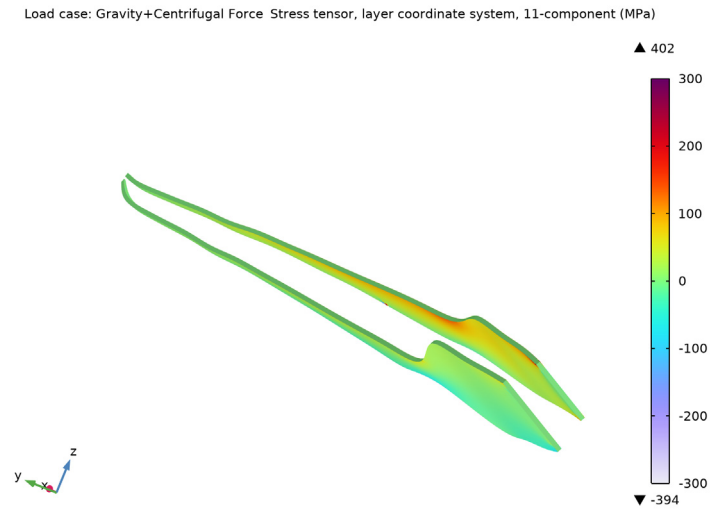

Figure 10: The stress distribution in the spars for combined gravitational and centrifugal loads.

Figure 9 shows the distribution of stress in the fiber direction in each layer of the skin and spars for a combined load case of gravitational and centrifugal forces. High stresses are present near the root of the blade and in the junction between the circular and airfoil cross sections. The stress distribution for the spars is shown separately in Figure 10. The stress distribution in the outermost carbon–epoxy laminate is shown in Figure 11 for the three load cases.

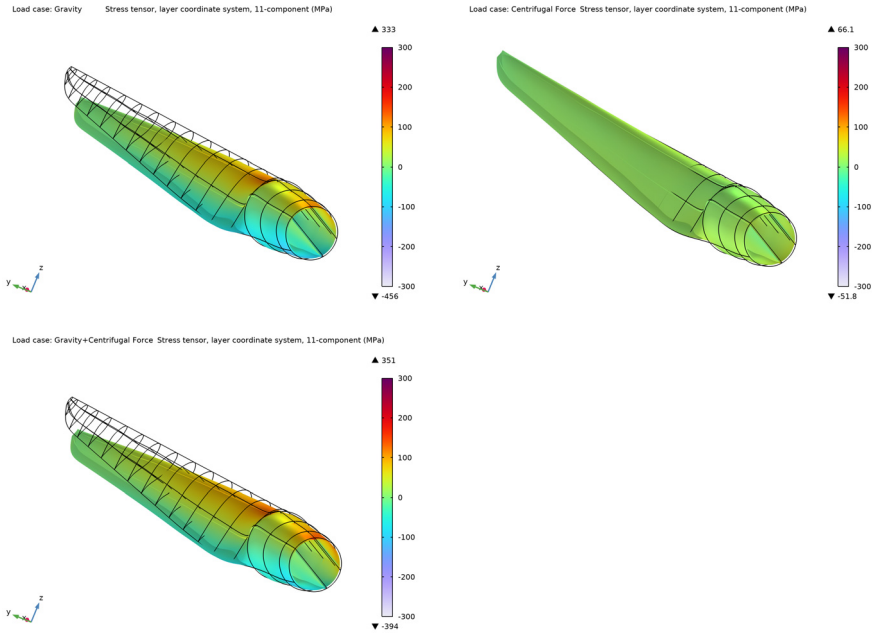
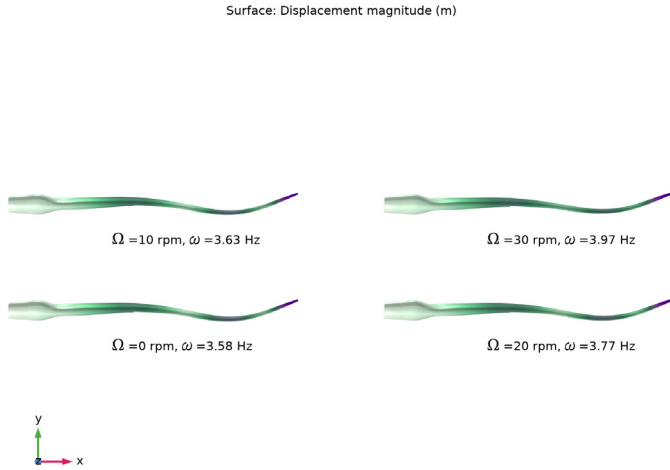
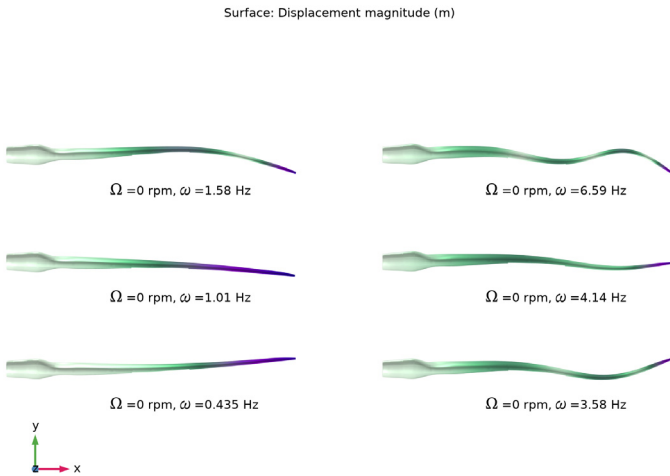

Figure 11: The stress distribution in the outermost carbon–epoxy layer for the three different load cases.



*Figure 12: The fourth mode shape of the blade for different blade speeds.*



*Figure 13: First six mode shapes of the blade when it is not rotating.*

In the second part of the example, a prestressed eigenfrequency analysis is carried out to compute eigenfrequencies and corresponding mode shapes of the blade under centrifugal

forces. Different mode shapes of the blade as well as the effect of centrifugal force on the mode shape are shown in Figure 12 and Figure 13.

A Campbell plot is created in order to understand the variation of eigenfrequencies with respect to the blade rotation speed as shown in Figure 14. The eigenfrequencies increase with an increase in the blade RPM. This is due to the centrifugal stiffening effect.

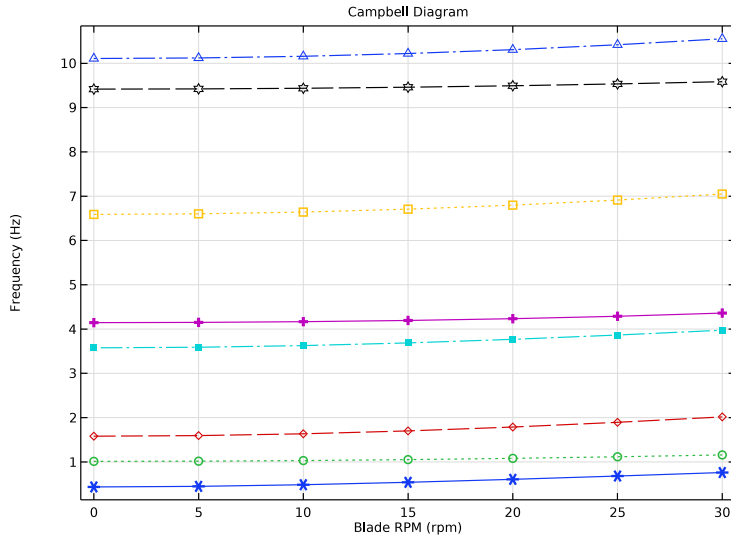

Figure 14: Campbell plot showing the variation of eigenfrequencies with an increase in the blade RPM.

### Notes About the COMSOL Implementation

- Modeling a composite laminate as a layered shell requires a surface geometry, in general referred to as a base surface, and a **Layered Material** node which adds an extra dimension (1D) to the base surface geometry in the surface normal direction. You can use the **Layered Material** functionality to model several layers stacked on top of each other having different thicknesses, material properties, and fiber orientations. You can optionally specify the interface materials between the layers, and control the number of through-thickness mesh elements for each layer.
- The third direction for the selected coordinate system in the **Single Layer Material**, **Layered Material Link**, or **Layered Material Stack** represents the normal direction of the **Layered Shell** or **Shell** physics. This is also the direction in which the layer stacking is

interpreted from bottom to top, and therefore, it is crucial to know it during modeling. There are two ways to achieve this:

- Using physics symbols: Go to the physics settings, find the **Physics Symbols** section, and select the **Enable physics symbols** checkbox. Then go to the material feature, for instance, **Linear Elastic Material**, to see the normal direction represented by green arrows in the geometry.
- Using result templates: When a solution dataset is available, use the result template **Thickness and Orientation** to plot the normal direction.
- From a constitutive model point of view, you can either use the *Layerwise (LW)* theory based **Layered Shell** interface, or the *Equivalent Single Layer (ESL)* theory based **Linear Elastic Material, Layered** node in the **Shell** interface. The laminated composite presented in the current model is modeled using a **Linear Elastic Material, Layered** node in the **Shell** interface.
- The built-in **Composites** material library contains data for fiber and matrix constituents as well as for unidirectional and bidirectional laminae.

## References

---

1. J. Jonkman and others, *Definition of a 5-MW Reference Wind Turbine for Offshore System Development, Technical Report*, NREL/TP-500-38060, 2009.
2. M.K. Yeh, and C.H. Wang, *Stress Analysis of Composite Wind Turbine Blade with Different Stacking Angle and Different Skin Thickness*, ICMSEA and MCEBM, 2017.
3. W.A. Timmer and R.P.J.O.M. van Rooij, “Summary of the Delft University Wind Turbine Dedicated Airfoils,” *J. Sol. Energy Eng.*, vol. 125, no. 4, pp. 488-496, 2003.
4. K. Kox and A. Echtermeyer, “Structural Design and Analysis of a 10MW Wind Turbine Blade,” *Energy Procedia*, vol. 24, pp. 194–201, 2012.

---

**Application Library path:** Composite\_Materials\_Module/  
Dynamics\_and\_Vibration/wind\_turbine\_composite\_blade

---

## Modeling Instructions



---

From the **File** menu, choose **New**.

## NEW

In the **New** window, click  **Model Wizard**.

## MODEL WIZARD

- 1 In the **Model Wizard** window, click .
- 2 In the **Select Physics** tree, select **Structural Mechanics > Shell (shell)**.
- 3 Click **Add**.
- 4 Click  **Study**.
- 5 In the **Select Study** tree, select **General Studies > Stationary**.
- 6 Click  **Done**.

## GLOBAL DEFINITIONS



### *Parameters I*

- 1 In the **Model Builder** window, under **Global Definitions** click **Parameters I**.
- 2 In the **Settings** window for **Parameters**, locate the **Parameters** section.
- 3 In the table, enter the following settings:

Name	Expression	Value	Description
th	0.28[mm]	2.8E-4 m	Layer thickness
thc	15[cm]	0.15 m	Core thickness
RPM	15[rpm]	0.25 1/s	Blade RPM
omega	2*pi[rad]*RPM	1.5708 rad/s	Blade angular speed

## GEOMETRY I

### *Import I (impl)*

- 1 In the **Model Builder** window, expand the **Component I (comp1) > Geometry I** node.
- 2 Right-click **Geometry I** and choose **Import**.
- 3 In the **Settings** window for **Import**, locate the **Source** section.
- 4 From the **Source** list, choose **COMSOL Multiphysics file**.
- 5 Click  **Browse**.
- 6 Browse to the model's Application Libraries folder and double-click the file `wind_turbine_composite_blade.mphbin`.
- 7 Click  **Import**.

You can adjust the view of the geometry for better visualization.

## DEFINITIONS

### *Skin Boundaries*

- 1 In the **Definitions** toolbar, click  **Explicit**.
- 2 In the **Settings** window for **Explicit**, type Skin Boundaries in the **Label** text field.
- 3 Locate the **Input Entities** section. From the **Geometric entity level** list, choose **Boundary**.
- 4 Select Boundary 50 only.
- 5 Select the **Group by continuous tangent** checkbox.

### *Spar Boundaries*

- 1 In the **Definitions** toolbar, click  **Explicit**.
- 2 In the **Settings** window for **Explicit**, type Spar Boundaries in the **Label** text field.
- 3 Locate the **Input Entities** section. From the **Geometric entity level** list, choose **Boundary**.
- 4 Select Boundaries 3 and 5 only.
- 5 Select the **Group by continuous tangent** checkbox.

### *Fixed Edges*

- 1 In the **Definitions** toolbar, click  **Explicit**.
- 2 In the **Settings** window for **Explicit**, type Fixed Edges in the **Label** text field.
- 3 Locate the **Input Entities** section. From the **Geometric entity level** list, choose **Edge**.
- 4 Select Edge 10 only.
- 5 Select the **Group by continuous tangent** checkbox.

### *Average I (aveopI)*

- 1 In the **Definitions** toolbar, click  **Nonlocal Couplings** and choose **Average**.
- 2 In the **Settings** window for **Average**, locate the **Source Selection** section.
- 3 From the **Geometric entity level** list, choose **Edge**.
- 4 From the **Selection** list, choose **Fixed Edges**.
- 5 Locate the **Advanced** section. From the **Frame** list, choose **Material (X, Y, Z)**.

### *Boundary System I (sysI)*



- 1 In the **Model Builder** window, click **Boundary System I (sysI)**.
- 2 In the **Settings** window for **Boundary System**, locate the **Settings** section.
- 3 Find the **Coordinate names** subsection. From the **Axis** list, choose **x**.

### *Reverse Normal I*

- 1 Right-click **Boundary System I (sysI)** and choose **Reverse Normal**.

- 2 In the **Settings** window for **Reverse Normal**, locate the **Boundary Selection** section.
- 3 From the **Selection** list, choose **Skin Boundaries**.

#### **GEOMETRY I**

- 1 In the **Model Builder** window, under **Component I (comp1)** click **Geometry I**.
- 2 In the **Graphics** window toolbar, click ▼ next to  **Select Objects**, then choose **Select Boundaries**.
- 3 Click the  **Click and Hide** button in the **Graphics** toolbar.  
You can hide parts of the skin to visualize the spars inside the blade.

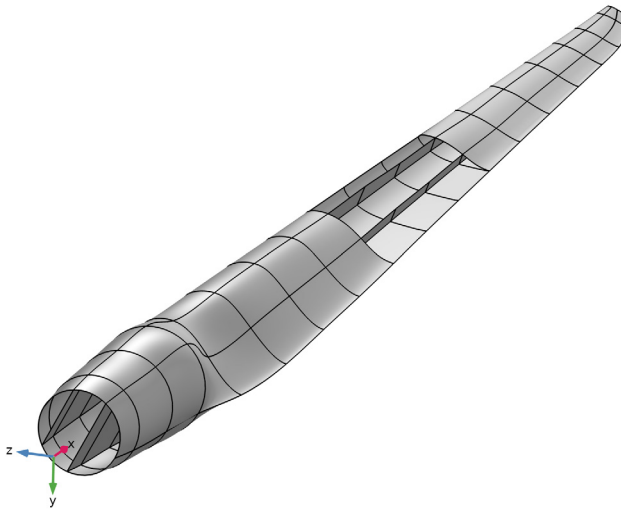

#### **GLOBAL DEFINITIONS**

*Material: Carbon-Epoxy*

- 1 In the **Model Builder** window, under **Global Definitions** right-click **Materials** and choose **Blank Material**.
- 2 In the **Settings** window for **Material**, type Material: Carbon-Epoxy in the **Label** text field.

*Layered Material: CE-[0]<sub>10</sub>*

- 1 Right-click **Materials** and choose **Layered Material**.
- 2 In the **Settings** window for **Layered Material**, type Layered Material: CE-[0]<sub>10</sub> in the **Label** text field.

3 Locate the **Layer Definition** section. In the table, enter the following settings:

Layer	Material	Rotation	Value	Thickness	Mesh elements
Layer 1	Material: Carbon-Epoxy (mat1)	0.0	0 rad	th*10	1

*Material: Glass-Vinylester*

1 Right-click **Materials** and choose **Blank Material**.

2 In the **Settings** window for **Material**, type Material: Glass-Vinylester in the **Label** text field.

*Layered Material: GV-[0/45/-45/90]\_s\_5*

1 Right-click **Materials** and choose **Layered Material**.

2 In the **Settings** window for **Layered Material**, type Layered Material: GV-[0/45/-45/90]\_s\_5 in the **Label** text field.

3 Locate the **Layer Definition** section. In the table, enter the following settings:

Layer	Material	Rotation	Value	Thickness	Mesh elements
Layer 1	Material: Glass-Vinylester (mat2)	0.0	0 rad	th*5	1

4 Click **Add** seven times.

5 In the table, enter the following settings:

Layer	Material	Rotation	Value	Thickness	Mesh elements
Layer 2	Material: Glass-Vinylester (mat2)	45	0.7854 rad	th*5	1
Layer 3	Material: Glass-Vinylester (mat2)	-45	-0.7854 rad	th*5	1
Layer 4	Material: Glass-Vinylester (mat2)	90	1.5708 rad	th*5	1

Layer	Material	Rotation	Value	Thickness	Mesh elements
Layer 5	Material: Glass-Vinylester (mat2)	90	1.5708 rad	th*5	1
Layer 6	Material: Glass-Vinylester (mat2)	-45	-0.7854 rad	th*5	1
Layer 7	Material: Glass-Vinylester (mat2)	45	0.7854 rad	th*5	1
Layer 8	Material: Glass-Vinylester (mat2)	0	0 rad	th*5	1

6 Click to expand the **Preview Plot Settings** section. In the **Thickness-to-width ratio** text field, type 0.6.

7 Locate the **Layer Definition** section. Click **Layer Stack Preview** in the upper-right corner of the section.

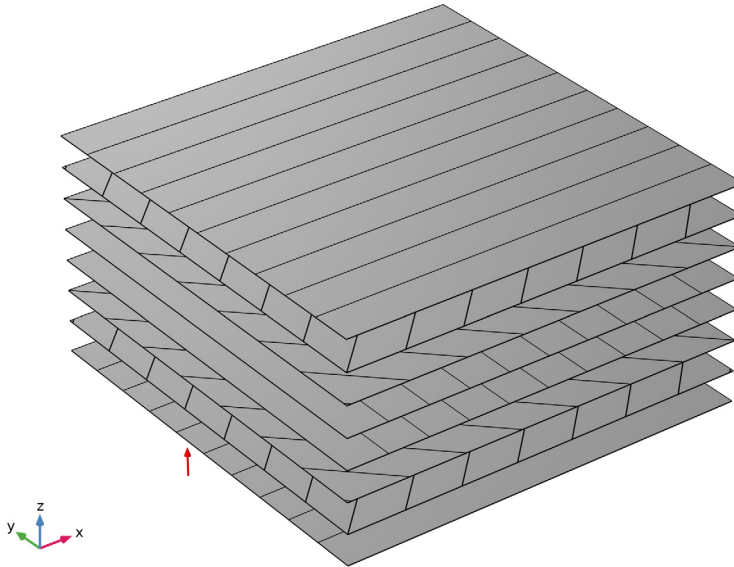

Material: PVC Foam

1 Right-click **Materials** and choose **Blank Material**.

2 In the **Settings** window for **Material**, type Material: PVC Foam in the **Label** text field.

*Layered Material: PF-[0]*

1 Right-click **Materials** and choose **Layered Material**.

2 In the **Settings** window for **Layered Material**, type Layered Material: PF-[0] in the **Label** text field.

3 Locate the **Layer Definition** section. In the table, enter the following settings:

Layer	Material	Rotation	Value	Thickness	Mesh elements
Layer 1	Material: PVC Foam (mat3)	0.0	0 rad	thc	1

## MATERIALS

Create a **Layered Material Stack** in which the previously created layered materials can be arranged to finalize the sandwich structure of the composite.

*Layered Material Stack 1 (stlmat1)*

In the **Model Builder** window, under **Component 1 (comp1)** right-click **Materials** and choose **Layers > Layered Material Stack**.

*Layered Material Link: Carbon-Epoxy*

In the **Settings** window for **Layered Material Link**, type Layered Material Link: Carbon-Epoxy in the **Label** text field.

*Layered Material Link: Glass-Vinylester*

1 Right-click **Layered Material Link: Carbon-Epoxy** and choose **Duplicate**.

2 In the **Settings** window for **Layered Material Link**, type Layered Material Link: Glass-Vinylester in the **Label** text field.

3 Locate the **Link Settings** section. From the **Material** list, choose **Layered Material: GV-[0/45/-45/90]\_s\_5 (lmat2)**.

*Layered Material Link: PVC Foam*

1 Right-click **Layered Material Link: Glass-Vinylester** and choose **Duplicate**.

2 In the **Settings** window for **Layered Material Link**, type Layered Material Link: PVC Foam in the **Label** text field.

3 Locate the **Link Settings** section. From the **Material** list, choose **Layered Material: PF-[0] (lmat3)**.

*Layered Material Link: Glass–Vinylester 1 (stlmat1.stllmat4)*

In the **Model Builder** window, under **Component 1 (comp1)** > **Materials** > **Layered Material Stack 1 (stlmat1)** right-click **Layered Material Link: Glass–Vinylester (stlmat1.stllmat2)** and choose **Duplicate**.

*Layered Material Link: Carbon–Epoxy 1 (stlmat1.stllmat5)*

In the **Model Builder** window, under **Component 1 (comp1)** > **Materials** > **Layered Material Stack 1 (stlmat1)** right-click **Layered Material Link: Carbon–Epoxy (stlmat1.stllmat1)** and choose **Duplicate**.

*Layered Material Stack 1 (stlmat1)*

- 1 In the **Settings** window for **Layered Material Stack**, click **Section\_bar** in the upper-right corner of the **Layered Material Settings** section. From the menu, choose **Layer Stack Preview**.
- 2 Click to expand the **Preview Plot Settings** section. In the **Thickness-to-width ratio** text field, type 0.4.
- 3 Clear the **Shows labels in cross-section plot** checkbox.
- 4 Locate the **Layered Material Settings** section. Click **Layer Cross-Section Preview** in the upper-right corner of the section.

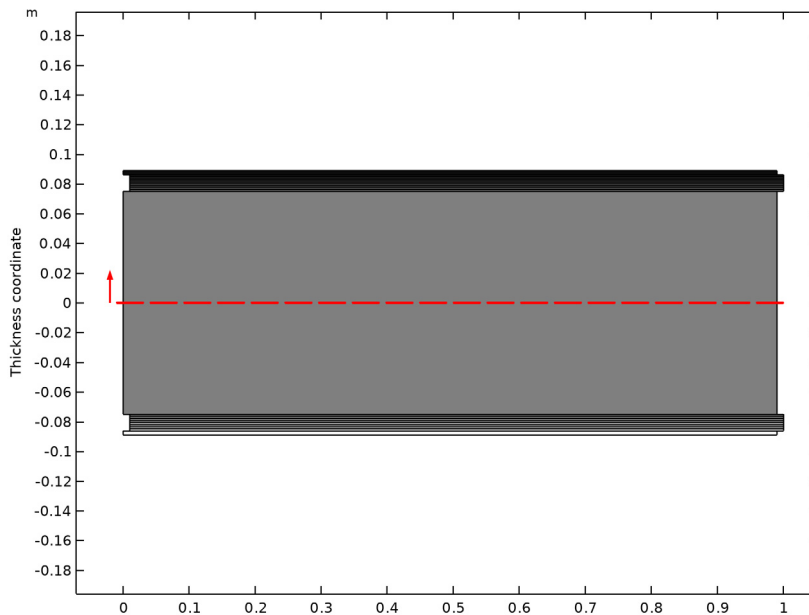

## SHELL (SHELL)

*Linear Elastic Material, Layered 1*

- 1 In the **Physics** toolbar, click  **Boundaries** and choose **Linear Elastic Material, Layered**.
- 2 In the **Settings** window for **Linear Elastic Material, Layered**, locate the **Boundary Selection** section.
- 3 From the **Selection** list, choose **All boundaries**.
- 4 Locate the **Linear Elastic Material** section. From the **Material symmetry** list, choose **Orthotropic**.
- 5 Select the **Transversely isotropic** checkbox.

Add the material properties of carbon–epoxy, glass–vinylester and PVC foam.

## GLOBAL DEFINITIONS

*Material: Carbon–Epoxy (mat1)*

- 1 In the **Model Builder** window, under **Global Definitions > Materials** click **Material: Carbon–Epoxy (mat1)**.
- 2 In the **Settings** window for **Material**, locate the **Material Contents** section.
- 3 In the table, enter the following settings:

Property	Variable	Value	Unit	Property group
Young's modulus	{Evect1, Evect2}	{139e9, 9e9}	Pa	Transversely isotropic
Poisson's ratio	{nuvect1, nuvect2}	{0.32, 0.32}	l	Transversely isotropic
Shear modulus	Gvect1	5.5e9	N/m <sup>2</sup>	Transversely isotropic
Density	rho	1560	kg/m <sup>3</sup>	Basic

*Material: Glass–Vinylester (mat2)*

- 1 In the **Model Builder** window, click **Material: Glass–Vinylester (mat2)**.
- 2 In the **Settings** window for **Material**, locate the **Material Contents** section.

3 In the table, enter the following settings:

Property	Variable	Value	Unit	Property group
Young's modulus	{Evect1, Evect2}	{41e9, 9e9}	Pa	Transversely isotropic
Poisson's ratio	{nuvect1, nuvect2}	{0.3, 0.3}	l	Transversely isotropic
Shear modulus	Gvect1	4.1e9	N/m <sup>2</sup>	Transversely isotropic
Density	rho	1890	kg/m <sup>3</sup>	Basic

*Material: PVC Foam (mat3)*

The PVC foam is isotropic. You just need to set the Young's modulus and Poisson's ratio. Orthotropic material properties will be synchronized from them.

- 1 In the **Model Builder** window, click **Material: PVC Foam (mat3)**.
- 2 In the **Settings** window for **Material**, click to expand the **Material Properties** section.
- 3 In the **Material properties** tree, select **Solid Mechanics > Linear Elastic Material > Young's Modulus and Poisson's Ratio**.
- 4 Click **+ Add to Material**.
- 5 Locate the **Material Contents** section. In the table, enter the following settings:

Property	Variable	Value	Unit	Property group
Young's modulus	E	250e6	Pa	Young's modulus and Poisson's ratio
Poisson's ratio	nu	0.35	l	Young's modulus and Poisson's ratio
Density	rho	200	kg/m <sup>3</sup>	Basic

- 6 Click the  **Show More Options** button in the **Model Builder** toolbar.
- 7 In the **Show More Options** dialog, in the tree, select the checkbox for the node **Physics > Advanced Physics Options**.
- 8 Click **OK**.

## **SHELL (SHELL)**

*Linear Elastic Material, Layered 1*



- 1 In the **Model Builder** window, under **Component 1 (comp1) > Shell (shell)** click **Linear Elastic Material, Layered 1**.

- 2 In the **Settings** window for **Linear Elastic Material, Layered**, click to expand the **Shear Correction Factor** section.
- 3 From the list, choose **User defined**.

*Fixed Constraint I*

- 1 In the **Physics** toolbar, click  **Edges** and choose **Fixed Constraint**.
- 2 In the **Settings** window for **Fixed Constraint**, locate the **Edge Selection** section.
- 3 From the **Selection** list, choose **Fixed Edges**.

*Gravity I*

- 1 In the **Physics** toolbar, click  **Global** and choose **Gravity**.
- 2 Click  **Load Group** and choose **New Load Group**.

**GLOBAL DEFINITIONS**

*Load Group: Gravity*

- 1 In the **Model Builder** window, under **Global Definitions > Load and Constraint Groups** click **Load Group I**.
- 2 In the **Settings** window for **Load Group**, type Load Group: Gravity in the **Label** text field.
- 3 In the **Parameter name** text field, type 1gG.

**SHELL (SHELL)**

*Rotating Frame I*

- 1 In the **Physics** toolbar, click  **Boundaries** and choose **Rotating Frame**.
- 2 In the **Settings** window for **Rotating Frame**, locate the **Rotating Frame** section.
- 3 From the **Axis of rotation** list, choose **User defined**. Specify the  $\mathbf{r}_{bp}$  vector as

aveop1 (X)	x
aveop1 (Y)	y
aveop1 (Z)	z

- 4 Specify the  $\mathbf{e}_{ax}$  vector as

0	x
1	y
0	z

- 5 In the  $\omega_r$  text field, type omega.
- 6 Locate the **Frame Acceleration Effect** section. Clear the **Spin softening** checkbox.
- 7 In the **Physics** toolbar, click  **Load Group** and choose **New Load Group**.

## GLOBAL DEFINITIONS

### *Load Group: Centrifugal Force*

- 1 In the **Model Builder** window, under **Global Definitions > Load and Constraint Groups** click **Load Group 2**.
- 2 In the **Settings** window for **Load Group**, type Load Group: Centrifugal Force in the **Label** text field.
- 3 In the **Parameter name** text field, type lgCF.

## MESH I

### *Mapped I*

- 1 In the **Mesh** toolbar, click  **More Generators** and choose **Mapped**.
- 2 In the **Settings** window for **Mapped**, locate the **Boundary Selection** section.
- 3 From the **Selection** list, choose **All boundaries**.

### *Size I*

- 1 Right-click **Mapped I** and choose **Size**.
- 2 In the **Settings** window for **Size**, click to expand the **Element Size Parameters** section.
- 3 Locate the **Element Size** section. Click the **Custom** button.
- 4 Locate the **Element Size Parameters** section.
- 5 Select the **Maximum element size** checkbox. In the associated text field, type 0.5.
- 6 In the **Model Builder** window, right-click **Mesh I** and choose **Build All**.

## STUDY: STATIC

- 1 In the **Model Builder** window, click **Study I**.
- 2 In the **Settings** window for **Study**, type Study: Static in the **Label** text field.

### *Step I: Stationary*

- 1 In the **Model Builder** window, under **Study: Static** click **Step I: Stationary**.
- 2 In the **Settings** window for **Stationary**, click to expand the **Study Extensions** section.
- 3 Select the **Define load cases** checkbox.

4 Click  **Add**.

Add two additional load cases.

5 In the table, enter the following settings:



Load case	IgG	Weight	IgCF	Weight
Load case: Gravity	√	1.0		1.0
Load case: Centrifugal Force		1.0	√	1.0
Load case: Gravity+Centrifugal Force	√	1.0	√	1.0

6 In the **Study** toolbar, click  **Compute**.

Set default units for result presentation.

## RESULTS

### *Preferred Units 1*

- 1 In the **Results** toolbar, click  **Configurations** and choose **Preferred Units**.
- 2 In the **Settings** window for **Preferred Units**, locate the **Units** section.
- 3 Click  **Add Physical Quantity**.
- 4 In the **Physical Quantity** dialog, select **Solid Mechanics** > **Stress tensor (N/m<sup>2</sup>)** in the tree.
- 5 Click **OK**.
- 6 In the **Settings** window for **Preferred Units**, locate the **Units** section.
- 7 In the table, enter the following settings:

Quantity	Unit	Preferred unit
Stress tensor	N/m <sup>2</sup>	MPa

8 Click  **Apply**.

### *Layered Material 1*

- 1 In the **Model Builder** window, expand the **Results** > **Datasets** node.
- 2 Right-click **Results** > **Datasets** and choose **More Datasets** > **Layered Material**.

### *Selection*

- 1 In the **Results** toolbar, click  **Attributes** and choose **Selection**.
- 2 In the **Settings** window for **Selection**, locate the **Geometric Entity Selection** section.
- 3 From the **Geometric entity level** list, choose **Boundary**.
- 4 From the **Selection** list, choose **Spar Boundaries**.

### *Stress: Skin+Spar*

- 1 In the **Model Builder** window, under **Results** click **Stress (shell)**.
- 2 In the **Settings** window for **3D Plot Group**, type **Stress: Skin+Spar** in the **Label** text field.
- 3 Locate the **Plot Settings** section. From the **View** list, choose **New view**.
- 4 Locate the **Color Legend** section. Select the **Show maximum and minimum values** checkbox.

### *Surface 1*

- 1 In the **Model Builder** window, expand the **Stress: Skin+Spar** node, then click **Surface 1**.
- 2 In the **Settings** window for **Surface**, locate the **Expression** section.
- 3 In the **Expression** text field, type `shell.s11Gp11`.
- 4 Click to expand the **Range** section. Select the **Manual color range** checkbox.
- 5 In the **Minimum** text field, type `-300`.
- 6 In the **Maximum** text field, type `300`.
- 7 In the **Stress: Skin+Spar** toolbar, click  **Plot**.

### *Stress: Spar*

- 1 In the **Model Builder** window, right-click **Stress: Skin+Spar** and choose **Duplicate**.
- 2 In the **Settings** window for **3D Plot Group**, type **Stress: Spar** in the **Label** text field.
- 3 Locate the **Data** section. From the **Dataset** list, choose **Layered Material 1**.
- 4 Locate the **Plot Settings** section. From the **View** list, choose **View 3D 3**.
- 5 Clear the **Plot dataset edges** checkbox.
- 6 In the **Stress: Spar** toolbar, click  **Plot**.

## **RESULT TEMPLATES**

- 1 In the **Results** toolbar, click  **Result Templates** to open the **Result Templates** window.
- 2 Go to the **Result Templates** window.
- 3 In the tree, select **Study: Static/Solution 1 (sol1) > Shell > Stress, Slice (shell)**.
- 4 Click the **Add Result Template** button in the window toolbar.

## **RESULTS**

### *Stress, Slice (Carbon-Epoxy)*

- 1 In the **Settings** window for **3D Plot Group**, type **Stress, Slice (Carbon-Epoxy)** in the **Label** text field.

- 2 Locate the **Color Legend** section. Select the **Show maximum and minimum values** checkbox.
- 3 In the **Model Builder** window, expand the **Stress, Slice (Carbon–Epoxy)** node.

#### *Layered Material Slice I*

- 1 In the **Model Builder** window, expand the **Results > Stress, Slice (Carbon–Epoxy) > Layered Material Slice I** node, then click **Layered Material Slice I**.
- 2 In the **Settings** window for **Layered Material Slice**, click to expand the **Range** section.
- 3 Locate the **Through-Thickness Location** section. In the **Local z-coordinate [-1,1]** text field, type 1.
- 4 Locate the **Range** section. Select the **Manual color range** checkbox.
- 5 In the **Minimum** text field, type -300.
- 6 In the **Maximum** text field, type 300.

#### *Stress, Slice (Carbon–Epoxy)*

- 1 In the **Model Builder** window, click **Stress, Slice (Carbon–Epoxy)**.
- 2 In the **Settings** window for **3D Plot Group**, locate the **Plot Settings** section.
- 3 From the **View** list, choose **View 3D 3**.
- 4 In the **Stress, Slice (Carbon–Epoxy)** toolbar, click  **Plot**.

#### *Stress, Slice*

- 1 In the **Model Builder** window, right-click **Stress, Slice (Carbon–Epoxy)** and choose **Duplicate**.
- 2 In the **Settings** window for **3D Plot Group**, type Stress, Slice in the **Label** text field.
- 3 Locate the **Plot Settings** section. Clear the **Plot dataset edges** checkbox.
- 4 From the **View** list, choose **New view**.

#### *Layered Material Slice I*

- 1 In the **Model Builder** window, expand the **Stress, Slice** node, then click **Layered Material Slice I**.
- 2 In the **Settings** window for **Layered Material Slice**, locate the **Through-Thickness Location** section.
- 3 From the **Location definition** list, choose **Physical**.
- 4 In the **Local z-coordinate** text field, type  $5*th$ ,  $17*th$ ,  $30*th$ ,  $50*th+0.5*thc$ ,  $70*th+thc$ ,  $83*th+thc$ ,  $95*th+thc$ .
- 5 Locate the **Layout** section. From the **Displacement** list, choose **Linear**.

- 6 In the **Relative z-separation** text field, type 0.3.
- 7 Select the **Show descriptions** checkbox.
- 8 In the **Relative separation** text field, type 0.35.
- 9 Locate the **Range** section. In the **Minimum** text field, type -100.
- 10 In the **Maximum** text field, type 100.

*Table Annotation 1*

- 1 In the **Model Builder** window, right-click **Stress, Slice** and choose **Table Annotation**.
- 2 In the **Settings** window for **Table Annotation**, locate the **Data** section.
- 3 From the **Source** list, choose **Local table**.
- 4 In the table, enter the following settings:

x-coordinate	y-coordinate	z-coordinate	Annotation
80	0	0	Carbon-Epoxy
80	0	18	Glass-Vinylester
80	0	37.5	Glass-Vinylester
80	0	56	PVC-Foam
80	0	76	Glass-Vinylester
80	0	94	Glass-Vinylester
80	0	112	Carbon-Epoxy

- 5 Locate the **Coloring and Style** section. Clear the **Show point** checkbox.
- 6 From the **Orientation** list, choose **Vertical**.

*Stress, Slice*

- 1 In the **Model Builder** window, click **Stress, Slice**.
- 2 In the **Stress, Slice** toolbar, click  **Plot**.

**RESULT TEMPLATES**

- 1 Go to the **Result Templates** window.
- 2 In the tree, select **Study: Static/Solution 1 (sol1) > Shell > Shell Geometry (shell)**.
- 3 Click the **Add Result Template** button in the window toolbar.
- 4 In the tree, select **Study: Static/Solution 1 (sol1) > Shell > Thickness and Orientation (shell)**.
- 5 Click the **Add Result Template** button in the window toolbar.
- 6 In the **Results** toolbar, click  **Result Templates** to close the **Result Templates** window.

## RESULTS

### *Shell Geometry (shell)*

- 1 In the **Settings** window for **3D Plot Group**, locate the **Plot Settings** section.
- 2 From the **View** list, choose **View 3D 3**.
- 3 In the **Shell Geometry (shell)** toolbar, click  **Plot**.

### *Thickness and Orientation (shell)*

- 1 In the **Model Builder** window, click **Thickness and Orientation (shell)**.
- 2 In the **Settings** window for **3D Plot Group**, locate the **Plot Settings** section.
- 3 From the **View** list, choose **View 3D 3**.

### *Thickness*

- 1 In the **Model Builder** window, expand the **Thickness and Orientation (shell)** node, then click **Thickness**.
- 2 In the **Settings** window for **Surface**, locate the **Coloring and Style** section.
- 3 From the **Coloring** list, choose **Uniform**.
- 4 From the **Color** list, choose **Gray**.
- 5 In the **Thickness and Orientation (shell)** toolbar, click  **Plot**.

### *Tip Displacement*

- 1 In the **Results** toolbar, click  **Evaluation Group**.
- 2 In the **Settings** window for **Evaluation Group**, type Tip Displacement in the **Label** text field.

### *Point Evaluation 1*



- 1 Right-click **Tip Displacement** and choose **Point Evaluation**.
- 2 Select Point 110 only.
- 3 In the **Settings** window for **Point Evaluation**, locate the **Expressions** section.
- 4 In the table, enter the following settings:

Expression	Unit	Description
shell.disp	m	Displacement magnitude

- 5 In the **Tip Displacement** toolbar, click  **Evaluate**.

Now you can add an **Eigenfrequency, Prestressed** study.

## ADD STUDY

- 1 In the **Home** toolbar, click  **Add Study** to open the **Add Study** window.
- 2 Go to the **Add Study** window.
- 3 Find the **Studies** subsection. In the **Select Study** tree, select **Preset Studies for Selected Physics Interfaces > Eigenfrequency, Prestressed**.
- 4 Click the **Add Study** button in the window toolbar.
- 5 In the **Home** toolbar, click  **Add Study** to close the **Add Study** window.

## STUDY: EIGENFREQUENCY

In the **Settings** window for **Study**, type **Study: Eigenfrequency** in the **Label** text field.

You can perform a parametric sweep for a range of blade RPMs, from 0 to 30 rpm.

### *Parametric Sweep*

- 1 In the **Study** toolbar, click  **Parametric Sweep**.
- 2 In the **Settings** window for **Parametric Sweep**, locate the **Study Settings** section.
- 3 Click **+ Add**.
- 4 In the table, enter the following settings:

Parameter name	Parameter value list	Parameter unit
RPM (Blade RPM)	range(0,5,30) [rpm]	1/s

- 5 In the table, click to select the cell at row number 1 and column number 3.

### *Step 1: Stationary*

- 1 In the **Model Builder** window, click **Step 1: Stationary**.
- 2 In the **Settings** window for **Stationary**, locate the **Study Extensions** section.
- 3 Select the **Define load cases** checkbox.
- 4 Click **+ Add**.
- 5 In the table, enter the following settings:

Load case	IgG	Weight	IgCF	Weight
Load Case: Centrifugal Force		1.0	√	1.0

### *Step 2: Eigenfrequency*

- 1 In the **Model Builder** window, click **Step 2: Eigenfrequency**.
- 2 In the **Settings** window for **Eigenfrequency**, locate the **Study Settings** section.

- 3 Select the **Desired number of eigenfrequencies** checkbox. In the associated text field, type 8.
- 4 In the **Study** toolbar, click  **Compute**.

## RESULTS

### *Mode Shapes (shell)*

- 1 In the **Settings** window for **3D Plot Group**, type **Mode Shapes (shell)** in the **Label** text field.
- 2 Click to expand the **Title** section. From the **Title type** list, choose **Custom**.
- 3 Find the **Solution** subsection. Clear the **Solution** checkbox.
- 4 Locate the **Data** section. From the **Eigenfrequency (Hz)** list, choose **4.3607**.
- 5 From the **Parameter value (RPM (1/s))** list, choose **0**.
- 6 Locate the **Plot Settings** section. Clear the **Plot dataset edges** checkbox.
- 7 Click to expand the **Plot Array** section. From the **Array type** list, choose **Square**.
- 8 In the **Model Builder** window, expand the **Mode Shapes (shell)** node.

### *Deformation*

- 1 In the **Model Builder** window, expand the **Results > Mode Shapes (shell) > Surface 1** node, then click **Deformation**.
- 2 In the **Settings** window for **Deformation**, locate the **Scale** section.
- 3 Select the **Scale factor** checkbox. In the associated text field, type 5e4.

### *Solution Array 1*

- 1 In the **Model Builder** window, right-click **Surface 1** and choose **Solution Array**.
- 2 In the **Settings** window for **Solution Array**, locate the **Data** section.
- 3 From the **Parameter selection (RPM)** list, choose **Manual**.
- 4 In the **Parameter indices (1-7)** text field, type 1.
- 5 From the **Eigenfrequency selection** list, choose **Manual**.
- 6 In the **Eigenfrequency indices (1-8)** text field, type range (1, 1, 6).
- 7 Locate the **Plot Array** section. From the **Array shape** list, choose **Square**.
- 8 From the **Order** list, choose **Column-major**.

### *Annotation 1*

- 1 In the **Model Builder** window, right-click **Mode Shapes (shell)** and choose **Annotation**.
- 2 In the **Settings** window for **Annotation**, locate the **Annotation** section.

- 3 From the **Geometry level** list, choose **Global**.
- 4 In the **Text** text field, type  $\Omega = \text{eval}(\text{RPM}, \text{rpm}, 3) \text{ rpm}, \Omega = \text{eval}(\text{freq}, \text{Hz}, 3) \text{ Hz}$ .
- 5 Select the **LaTeX markup** checkbox.
- 6 Locate the **Position** section. In the **x** text field, type 20.
- 7 In the **y** text field, type -5.
- 8 Locate the **Coloring and Style** section. Clear the **Show point** checkbox.
- 9 Click to expand the **Plot Array** section. Select the **Manual indexing** checkbox.



#### *Solution Array 1*

In the **Model Builder** window, under **Results > Mode Shapes (shell) > Surface 1** right-click **Solution Array 1** and choose **Copy**.

#### *Solution Array 1*

In the **Model Builder** window, right-click **Annotation 1** and choose **Paste Solution Array**.

#### *Mode Shapes (shell)*

- 1 Click the  **Go to XY View** button in the **Graphics** toolbar.
- 2 Click the  **Show Grid** button in the **Graphics** toolbar.
- 3 In the **Mode Shapes (shell)** toolbar, click  **Plot**.

#### *Campbell Diagram*

- 1 In the **Results** toolbar, click  **ID Plot Group**.
- 2 In the **Settings** window for **ID Plot Group**, type Campbell Diagram in the **Label** text field.
- 3 Locate the **Data** section. From the **Dataset** list, choose **Study: Eigenfrequency/ Parametric Solutions 1 (sol4)**.
- 4 Click to expand the **Title** section. From the **Title type** list, choose **Label**.
- 5 Locate the **Plot Settings** section.
- 6 Select the **y-axis label** checkbox. In the associated text field, type Frequency (Hz).
- 7 Locate the **Legend** section. Clear the **Show legends** checkbox.

#### *Global 1*

- 1 Right-click **Campbell Diagram** and choose **Global**.
- 2 In the **Settings** window for **Global**, locate the **y-Axis Data** section.

3 In the table, enter the following settings:

Expression	Unit	Description
freq	1/s	Frequency

- 4 Locate the **x-Axis Data** section. From the **Axis source data** list, choose **Outer solutions**.
- 5 From the **Parameter** list, choose **Expression**.
- 6 In the **Expression** text field, type RPM.
- 7 In the **Unit** field, type rpm.
- 8 Click to expand the **Coloring and Style** section. Find the **Line style** subsection. From the **Line** list, choose **Cycle**.
- 9 Find the **Line markers** subsection. From the **Marker** list, choose **Cycle**.
- 10 In the **Campbell Diagram** toolbar, click  **Plot**.