



Model created in COMSOL Multiphysics 6.4

# Piezoelectricity in a Layered Shell

## Introduction

---

This tutorial is intended as a simple example showing how to model piezoelectric devices using the **Layered Shell** functionality. Two cases of material orientation are investigated. In the first case, the pole axis is normal to the shell surface, which results in a change in thickness of the deformed shell. In the second case, the pole axis is tangential to the shell, which leads to the shell bending.



Read more about the Composite Materials Module and piezoelectricity modeling in the following COMSOL blogs:

- [Introduction to the Composite Materials Module.](#)
- [Modeling Piezoelectricity: Which Module to Use?](#)

---

**Note:** This model requires either MEMS or AC/DC Module.

---

## Model Definition

---

In this tutorial, you model a thin structure with three layers. The top and bottom layers are electric conductors, and the middle one is a piezoelectric material. The geometry of the structure is shown in [Figure 1](#).

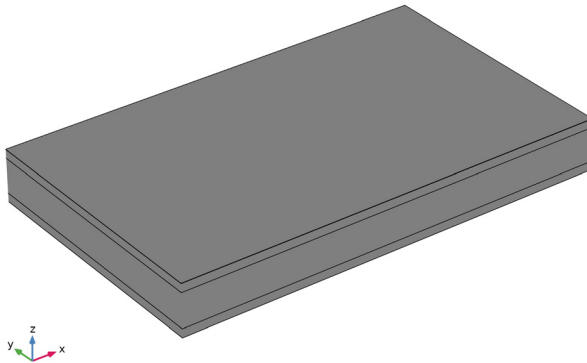

*Figure 1: Layered shell geometry representation in 3D.*

The modeling approach in this tutorial is based on the layered shell technology available in COMSOL Multiphysics. Thus, you represent the geometry by a surface in 3D space, which gives the base of the layered structure; see [Figure 2](#).

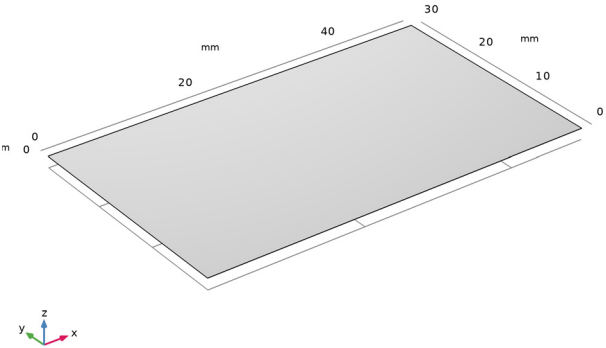

*Figure 2: Model geometry representation as a surface.*

You also use the surface for meshing, which gives the in-plane part of the discretized representation of the model; see [Figure 3](#).

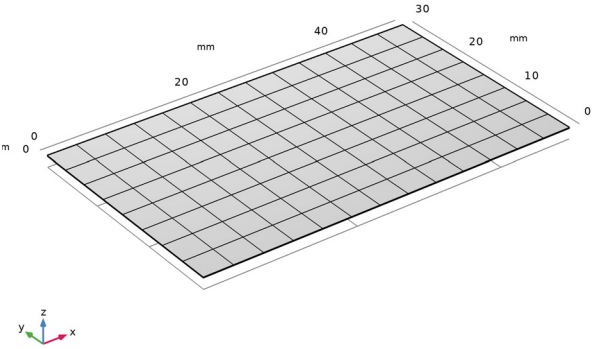

*Figure 3: Meshed base selection.*

The out-of-plane structure of the shell is modeled using an extra dimension attached to the base selection. The extra dimension together with the base selection span a local 3-dimensional space in which the equations are solved.

The extra dimension is set up using a special **Layered Material** node, which allows you to change the number of layers as well as their thickness and in-plane rotation, and to change the number of mesh elements used in each layer in the extra dimension. You can also select the materials to be used in each layer.

### Materials

The structure in this tutorial has three layers. The top and bottom ones represent 1 mm thick conductors made of aluminum. The layer in the middle has a thickness of 4 mm and is composed of a piezoelectric material called Lead Zirconate Titanate (PZT-5H).

For a piezoelectric material, the inelastic contributions to strain due to applied electric field  $\mathbf{E}$  can be written in the strain-charge form as

$$\begin{bmatrix} \varepsilon_{xx} & \varepsilon_{yy} & \varepsilon_{zz} & 2\varepsilon_{yz} & 2\varepsilon_{xz} & 2\varepsilon_{xy} \end{bmatrix} = d^T \mathbf{E}$$

For materials with tetragonal symmetry (class  $4mm$ ) such as PZT-5H, the coupling matrix has the following structure (Ref. 1):

$$d = \begin{bmatrix} 0 & 0 & 0 & 0 & d_{15} & 0 \\ 0 & 0 & 0 & d_{15} & 0 & 0 \\ d_{31} & d_{31} & d_{33} & 0 & 0 & 0 \end{bmatrix} \quad (1)$$

Here, the pole direction is along the third coordinate axis (the  $z$ -axis). Such orientation is assumed for all the piezoelectric material data available in COMSOL Material Library. For PZT-5H, the following values are used:  $d_{31} = -2.74 \cdot 10^{-10}$  C/N,  $d_{33} = 5.93 \cdot 10^{-10}$  C/N, and  $d_{15} = 7.41 \cdot 10^{-10}$  C/N.

When the electric field has only one component,  $E_z$ , the only nonzero contributions to the strain are:  $\varepsilon_{xx} = \varepsilon_{yy} = d_{31}E_z$  and  $\varepsilon_{zz} = d_{33}E_z$ .

In this example, the electric field component  $E_z$  is positive. Hence, the piezoelectric layer will tend to stretch in the  $z$  direction and shrink in the other two directions.

When the pole direction is changed to the  $x$ -axis, the first and last lines in the coupling matrix will be swapped. As a result, the only nonzero contribution to the strain will be  $\varepsilon_{xz} = 0.5d_{15}E_z$  so that the piezo layer will be sheared in the  $xz$ -plane.

### Boundary Conditions

At  $x = 0$ , the whole cross section of the layered shell (the  $yz$ -plane) is mechanically fixed; see Figure 1. The ground condition is applied to the top conducting interface, and a fixed electric potential of 20 V is applied to the bottom interface. All other boundaries are free.

## Results and Discussion

Two different cases of poling directions of piezoelectric materials are considered: the pole axis in the  $z$  direction and the pole axis in the  $x$  direction. In both cases, the electric potential distribution is similar; see [Figure 4](#).

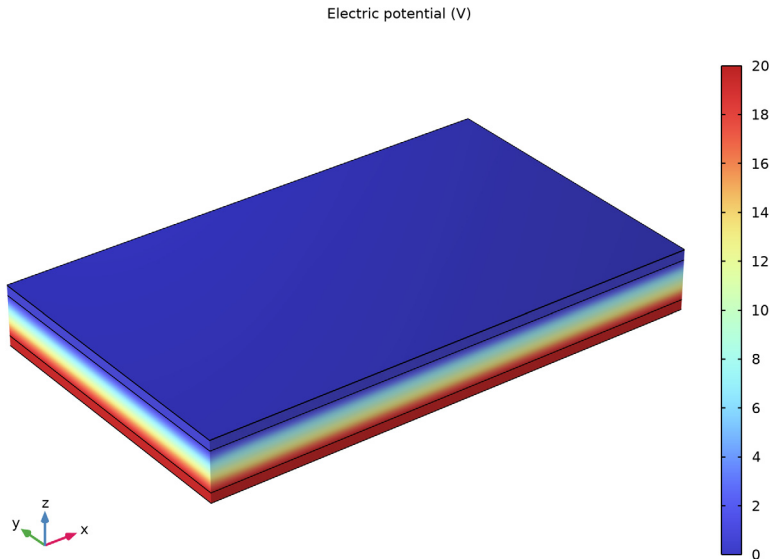
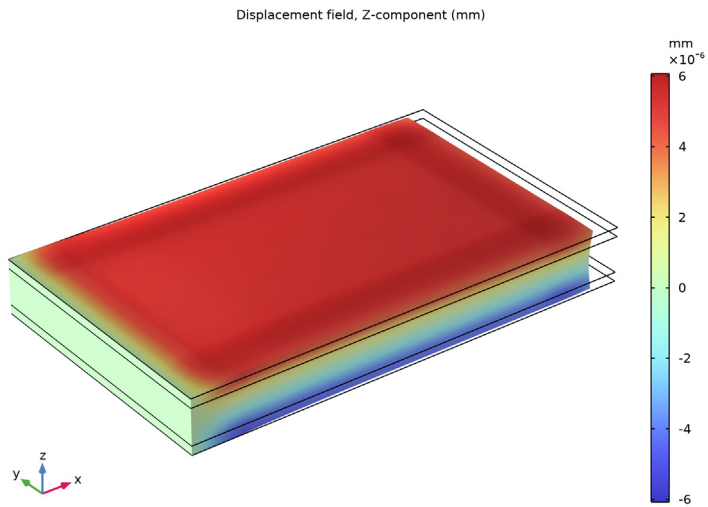

*Figure 4: Electric potential distribution.*

In the first case, the material has a default orientation with the  $z$ -axis as the pole direction, which is normal to the shell. The structure deformation is shown in [Figure 5](#).

In the second study, the material orientation is changed so that the pole direction is in-plane along the  $x$ -axis. The nature of resulting structural deformation is significantly different; see [Figure 6](#).

The results show that using a correct choice of the material orientation is essential when modeling piezoelectric applications.



*Figure 5: Vertical displacement for the case where the z-axis is the pole direction in the piezoelectric layer.*

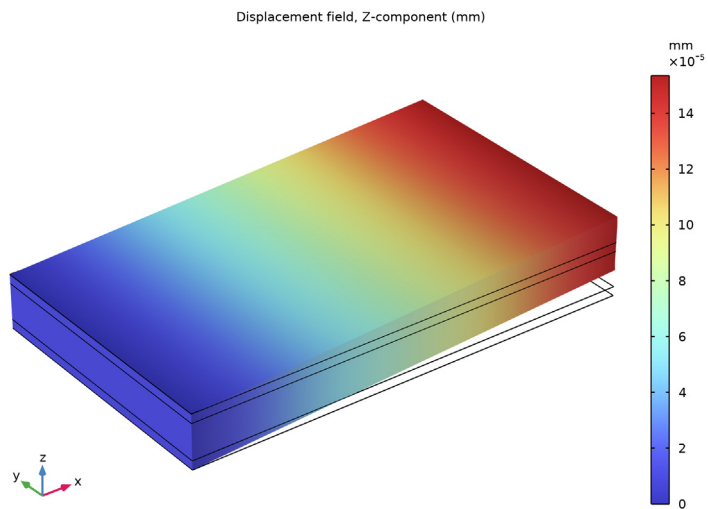

*Figure 6: Vertical displacement for the case where the x-axis is the pole direction in the piezoelectric layer.*

## *Notes About the COMSOL Implementation*

---

- Modeling a composite laminate as a layered shell requires a surface geometry, in general referred to as a base surface, and a **Layered Material** node which adds an extra dimension (1D) to the base surface geometry in the surface normal direction. You can use the **Layered Material** functionality to model several layers stacked on top of each other having different thicknesses, material properties, and fiber orientations. You can optionally specify the interface materials between the layers, and control the number of through-thickness mesh elements for each layer.
- The third direction for the selected coordinate system in the **Single Layer Material**, **Layered Material Link**, or **Layered Material Stack** represents the normal direction of the **Layered Shell** or **Shell** physics. This is also the direction in which the layer stacking is interpreted from bottom to top, and therefore, it is crucial to know it during modeling. There are two ways to achieve this:
  - Using physics symbols: Go to the physics settings, find the **Physics Symbols** section, and select the **Enable physics symbols** checkbox. Then go to the material feature, for instance, **Linear Elastic Material**, to see the normal direction represented by green arrows in the geometry.
  - Using result templates: When a solution dataset is available, use the result template **Thickness and Orientation** to plot the normal direction.
- The device is modeled in 3D using the predefined multiphysics interface **Piezoelectricity, Layered Shell**. Two physics interfaces, structural **Layered Shell** and **Electric Currents in Layered Shells**, will automatically be added to the model together with a multiphysics coupling feature called **Piezoelectric Effect, Layered**.
- The **Layered Shell** interface will contain a **Piezoelectric Material** node, where you can select geometry boundary for the base surface, and also select certain layers within the layered material. The **Electric Currents in Layered Shells** interface will contain a node **Piezoelectric Layer**, where a similar selection should be made. It is important to have the same selections under both interfaces. All settings for the material properties and orientation can be found under the **Piezoelectric Material** node within the **Layered Shell** interface. This includes the structural, dielectric, and coupling properties.

## *References*

---

I. A.L. Kholkin, N.A. Pertsev, and A.V. Goltsev, "Piezoelectricity and Crystal Symmetry," *Piezoelectric and Acoustic Materials for Transducer Applications*, A. Safari and E.K. Akdogan, eds., Springer, Boston, MA, 2008.

---

**Application Library path:** Composite\_Materials\_Module/Multiphysics/  
piezoelectric\_layered

---

### *Modeling Instructions*



---

From the **File** menu, choose **New**.

#### **NEW**

In the **New** window, click  **Model Wizard**.

#### **MODEL WIZARD**

- 1 In the **Model Wizard** window, click  **3D**.
- 2 In the **Select Physics** tree, select **Structural Mechanics > Electromagnetics–Structure Interaction > Piezoelectricity > Piezoelectricity, Layered Shell**.
- 3 Click **Add**.
- 4 Click  **Study**.
- 5 In the **Select Study** tree, select **General Studies > Stationary**.
- 6 Click  **Done**.

#### **GEOMETRY I**

- 1 In the **Model Builder** window, under **Component I (comp I)** click **Geometry I**.
- 2 In the **Settings** window for **Geometry**, locate the **Units** section.
- 3 From the **Length unit** list, choose **mm**.

*Work Plane 1 (wp1)*

- 1 In the **Geometry** toolbar, click  **Work Plane**.
- 2 In the **Settings** window for **Work Plane**, click  **Go to Plane Geometry**.

*Work Plane 1 (wp1) > Plane Geometry*

In the **Model Builder** window, click **Plane Geometry**.

*Work Plane 1 (wp1) > Rectangle 1 (r1)*

- 1 In the **Work Plane** toolbar, click  **Rectangle**.
- 2 In the **Settings** window for **Rectangle**, locate the **Size and Shape** section.
- 3 In the **Width** text field, type 50.

4 In the **Height** text field, type 30.

*Array 1 (arr1)*

1 In the **Geometry** toolbar, click  **Transforms** and choose **Array**.

2 Select the object **wp1** only.

3 In the **Settings** window for **Array**, locate the **Size** section.

4 In the **y size** text field, type 2.

5 Locate the **Displacement** section. In the **y** text field, type 50.

6 Click  **Build Selected**.

7 Click the  **Zoom Extents** button in the **Graphics** toolbar.

Next, add the materials, aluminum and PZT-5H from the **Material Library**.

#### ADD MATERIAL

1 In the **Materials** toolbar, click  **Add Material** to open the **Add Material** window.

2 Go to the **Add Material** window.

3 In the tree, select **Built-in > Aluminum**.

4 Right-click and choose **Add to Global Materials**.

5 In the tree, select **Built-in > Lead Zirconate Titanate (PZT-5H)**.

6 Right-click and choose **Add to Global Materials**.

7 In the **Materials** toolbar, click  **Add Material** to close the **Add Material** window.

Add a layered material node and defined a stacking sequence. Here you can also change the number of mesh elements used in the thickness direction.

#### GLOBAL DEFINITIONS

*Layered Material 1 (lmat1)*

1 In the **Model Builder** window, under **Global Definitions** right-click **Materials** and choose **Layered Material**.

2 In the **Settings** window for **Layered Material**, locate the **Layer Definition** section.

3 Click  **Add** twice.

4 In the table, enter the following settings:

Layer	Material	Rotation	Value	Thickness	Mesh elements
Layer 1	Aluminum (mat1)	0.0	0 rad	1 [mm]	2
Layer 2	Lead Zirconate Titanate (PZT-5H) (mat2)	0.0	0 rad	4 [mm]	4
Layer 3	Aluminum (mat1)	0.0	0 rad	1 [mm]	2

You can preview the laminate cross section.

- 5 Click to expand the **Preview Plot Settings** section. In the **Thickness-to-width ratio** text field, type 8/30.
- 6 Locate the **Layer Definition** section. Click **Layer Cross-Section Preview** in the upper-right corner of the section.

Add a layered material link node to make the layered material available in **Component 1**. Using this node, you can also select a coordinate system defining the orientation. Note that only boundary coordinate systems can be selected.

## MATERIALS

### *Layered Material Link 1 (lmat1)*

In the **Model Builder** window, under **Component 1 (comp1)** right-click **Materials** and choose **Layers > Layered Material Link**.

Next, select only the middle layer of the laminate to use the piezoelectric material.

## ELECTRIC CURRENTS IN LAYERED SHELLS (ECIS)

### *Piezoelectric Layer 1*

- 1 In the **Model Builder** window, under **Component 1 (comp1)** > **Electric Currents in Layered Shells (ecis)** click **Piezoelectric Layer 1**.
- 2 In the **Settings** window for **Piezoelectric Layer**, locate the **Shell Properties** section.
- 3 Clear the **Use all layers** checkbox.
- 4 In the **Selection** table, clear the checkboxes for **Layer 1** and **Layer 3**.

## LAYERED SHELL (LSHELL)

### *Piezoelectric Material (Z Pole Axis)*

- 1 In the **Model Builder** window, under **Component 1 (comp1) > Layered Shell (lshell)** click **Piezoelectric Material 1**.
- 2 In the **Settings** window for **Piezoelectric Material**, type Piezoelectric Material (Z Pole Axis) in the **Label** text field.
- 3 Locate the **Boundary Selection** section. Click  **Clear Selection**.
- 4 Select Boundary 1 only.
- 5 Locate the **Shell Properties** section. Clear the **Use all layers** checkbox.
- 6 In the **Selection** table, clear the checkboxes for **Layer 1** and **Layer 3**.
- 7 Locate the **Piezoelectric Material Properties** section. From the **Constitutive relation** list, choose **Strain–charge form**.

Add a new **Piezoelectric Material** feature and change the orientation of the piezoelectric layer.

### *Piezoelectric Material (X Pole Axis)*

- 1 Right-click **Piezoelectric Material (Z Pole Axis)** and choose **Duplicate**.
- 2 In the **Settings** window for **Piezoelectric Material**, type Piezoelectric Material (X Pole Axis) in the **Label** text field.
- 3 Locate the **Boundary Selection** section. Click  **Clear Selection**.
- 4 Select Boundary 2 only.
- 5 Click to expand the **Out-of-Plane Material Orientation** section. The layered material always operates with a boundary coordinate system on the base surface (laminated system). For such systems, the third base vector direction is always normal to the surface.  
Use a special control if you need to change the out-of-plane orientation of the material.
- 6 From the **Use laminate coordinate system with** list, choose **Swapped normal and 1st tangential directions**.

Next, set up the boundary conditions for the structure and the charge balance. Note that you need to operate with edges of the base surface.

### *Fixed Constraint 1*

- 1 In the **Physics** toolbar, click  **Edges** and choose **Fixed Constraint**.
- 2 Select Edges 1 and 4 only.

## ELECTRIC CURRENTS IN LAYERED SHELLS (ECIS)

### *Conductive Shell 1*

In the **Model Builder** window, under **Component 1 (comp1) > Electric Currents in Layered Shells (ecis)** click **Conductive Shell 1**.

### *Ground 1*

In the **Physics** toolbar, click  **Attributes** and choose **Ground**.

### *Conductive Shell 1*

In the **Model Builder** window, click **Conductive Shell 1**.

### *Electric Potential 1*

- 1 In the **Physics** toolbar, click  **Attributes** and choose **Electric Potential**.
- 2 In the **Settings** window for **Electric Potential**, locate the **Interface Selection** section.
- 3 From the **Apply to** list, choose **Bottom interface**.
- 4 Locate the **Electric Potential** section. In the  $V_0$  text field, type 20.

## MESH 1

### *Mapped 1*

- 1 In the **Mesh** toolbar, click  **More Generators** and choose **Mapped**.
- 2 In the **Settings** window for **Mapped**, locate the **Boundary Selection** section.
- 3 From the **Selection** list, choose **All boundaries**.

### *Size*

- 1 In the **Model Builder** window, click **Size**.
- 2 In the **Settings** window for **Size**, locate the **Element Size** section.
- 3 From the **Predefined** list, choose **Fine**.
- 4 Click  **Build All**.

## STUDY 1

- 1 In the **Model Builder** window, click **Study 1**.
- 2 In the **Settings** window for **Study**, locate the **Study Settings** section.
- 3 Clear the **Generate default plots** checkbox.
- 4 In the **Study** toolbar, click  **Compute**.

## RESULTS

Add a **Layered Material** dataset that will allow a 3D representation of the laminate.

### *Layered Material I*

- 1 In the **Model Builder** window, expand the **Results** node.
- 2 Right-click **Results > Datasets** and choose **More Datasets > Layered Material**.



### *Selection*

- 1 In the **Results** toolbar, click  **Attributes** and choose **Selection**.
- 2 In the **Settings** window for **Selection**, locate the **Geometric Entity Selection** section.
- 3 From the **Geometric entity level** list, choose **Boundary**.
- 4 Select Boundary 1 only.

### *Electric Potential*

- 1 In the **Results** toolbar, click  **3D Plot Group**.
- 2 In the **Settings** window for **3D Plot Group**, type Electric Potential in the **Label** text field.
- 3 Locate the **Data** section. From the **Dataset** list, choose **Layered Material I**.

### *Surface I*

- 1 Right-click **Electric Potential** and choose **Surface**.
- 2 In the **Settings** window for **Surface**, locate the **Expression** section.
- 3 In the **Expression** text field, type  $V$ .
- 4 Locate the **Coloring and Style** section. From the **Color table** list, choose **RainbowLight**.
- 5 In the **Electric Potential** toolbar, click  **Plot**.
- 6 Click the  **Show Grid** button in the **Graphics** toolbar.



### *Vertical Displacement (Z Pole Axis)*

- 1 In the **Results** toolbar, click  **3D Plot Group**.
- 2 In the **Settings** window for **3D Plot Group**, type Vertical Displacement (Z Pole Axis) in the **Label** text field.
- 3 Locate the **Data** section. From the **Dataset** list, choose **Layered Material I**.
- 4 Locate the **Color Legend** section. Select the **Show units** checkbox.

### *Surface I*

- 1 Right-click **Vertical Displacement (Z Pole Axis)** and choose **Surface**.
- 2 In the **Settings** window for **Surface**, locate the **Expression** section.
- 3 In the **Expression** text field, type  $w$ .
- 4 Locate the **Coloring and Style** section. From the **Color table** list, choose **RainbowLight**.

### *Deformation 1*

- 1 Right-click **Surface 1** and choose **Deformation**.
- 2 In the **Vertical Displacement (Z Pole Axis)** toolbar, click  **Plot**.
- 3 Click the  **Go to Default View** button in the **Graphics** toolbar.



### *Layered Material 2*

In the **Model Builder** window, under **Results > Datasets** right-click **Layered Material 1** and choose **Duplicate**.

### *Selection*

- 1 In the **Model Builder** window, expand the **Layered Material 2** node, then click **Selection**.
- 2 In the **Settings** window for **Selection**, locate the **Geometric Entity Selection** section.
- 3 Click  **Clear Selection**.
- 4 Select Boundary 2 only.

### *Vertical Displacement (X Pole Axis)*

- 1 In the **Model Builder** window, right-click **Vertical Displacement (Z Pole Axis)** and choose **Duplicate**.
- 2 In the **Settings** window for **3D Plot Group**, type Vertical Displacement (X Pole Axis) in the **Label** text field.
- 3 Locate the **Data** section. From the **Dataset** list, choose **Layered Material 2**.
- 4 Locate the **Plot Settings** section. From the **View** list, choose **New view**.
- 5 In the **Vertical Displacement (X Pole Axis)** toolbar, click  **Plot**.
- 6 Click the  **Show Grid** button in the **Graphics** toolbar.