



Model created in COMSOL Multiphysics 6.4

# Heating Circuit – Layered Shell Version

## Introduction

---

Small heating circuits find use in many applications. For example, in manufacturing processes they heat up reactive fluids. [Figure 1](#) illustrates a typical heating device shown in this model. The device consists of an electrically resistive layer deposited on a glass plate. The layer causes Joule heating when a voltage is applied to the circuit. The layer's properties determine the amount of heat produced.

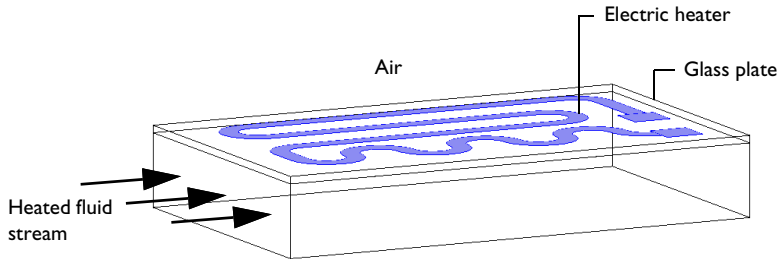

*Figure 1: Geometry of a heating device.*

In this particular model, there are three important design considerations:

- Noninvasive heating
- Minimal deflection of the heating device
- Avoidance of overheating the process fluid

The heater must also work without failure. The first and second requirements are achieved by inserting a glass plate between the heating circuit and the fluid; it acts as a conducting separator. Glass is an ideal material for both these purposes because it is nonreactive and has a low coefficient of thermal expansion.

Overheating must be avoided due to the risk of self-ignition of the reactive fluid stream. Ignition is also the main reason for separating the electrical circuit from direct contact with the fluid. Heating devices are tailored for each application, making virtual prototyping very important for manufacturers.

For heating circuits in general, the detachment of the resistive layer often determines the failure rate. This is caused by excessive thermally induced interfacial stresses. Once the layer has detached, it gets locally overheated, which further accelerates the detachment. Finally, in the worst case, the circuit might overheat and burn. From this perspective, it is also important to study the interfacial tension due to the different thermal expansion

coefficients of the resistive layer and the substrate as well as the differences in temperature. The geometric shape of the layer is a key parameter to design circuits for proper functioning. You can investigate all of the abovementioned aspects by modeling the circuit.

This multiphysics example simulates the electrical heat generation, the heat transfer, and the mechanical stresses and deformations of a heating circuit device. The model uses the Heat Transfer in Shells interface of the Heat Transfer Module in combination with the Electric Currents, Layered Shell interface from the AC/DC Module or the MEMS Module, and the Layered Shell interface from the Composite Materials Module.



Read more about the Composite Materials Module in the COMSOL blog, [Introduction to the Composite Materials Module](#).

---

**Note:** In addition to the Composite Materials Module and the Structural Mechanics Module, this model requires the Heat Transfer Module and either the AC/DC Module or the MEMS Module. It is a layered shell version of the model *Heating Circuit* available in the AC/DC Module, Heat Transfer Module, and Structural Mechanics Module Application Libraries.

---

### *Model Definition*

---

**Figure 2** shows a drawing of the modeled heating circuit.

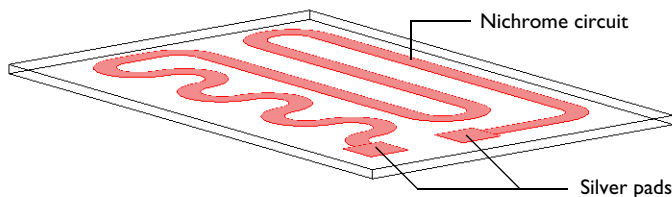

*Figure 2: Drawing of the heating circuit deposited on a glass plate.*

The device consists of a serpentine-shaped Nichrome resistive layer, 10  $\mu\text{m}$  thick and 5 mm wide, deposited on a glass plate. At each end, it has a silver contact pad measuring

10 mm by 10 mm by 10  $\mu\text{m}$ . When the circuit is in use, the deposited side of the glass plate is in contact with surrounding air, and the back side is in contact with the heated fluid. Assume that the edges and sides of the glass plate are thermally insulated.

Table 1 lists the resistor's dimensions.

TABLE 1: DIMENSIONS.

OBJECT	LENGTH	WIDTH	THICKNESS
Glass plate	130 mm	80 mm	2 mm
Pads and circuit	-	-	10 $\mu\text{m}$

### LAYERED SHELL APPROACH

Since this model uses a layered shell interface, in which the through thickness integration is inherent to the layered shell formulation itself, a surface geometry as shown in the Figure 3 is sufficient.

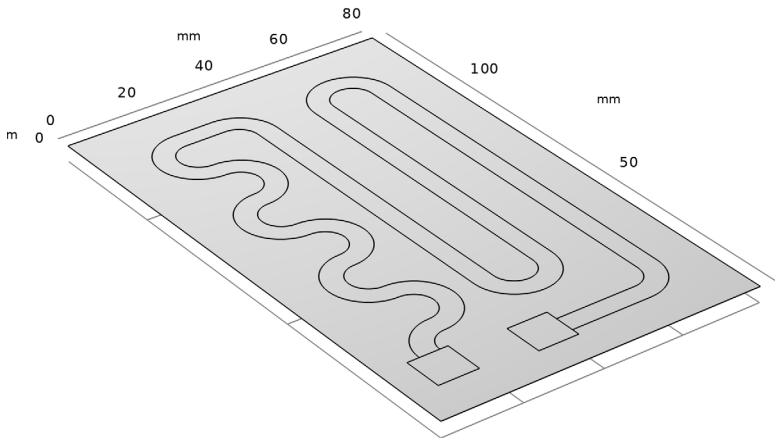
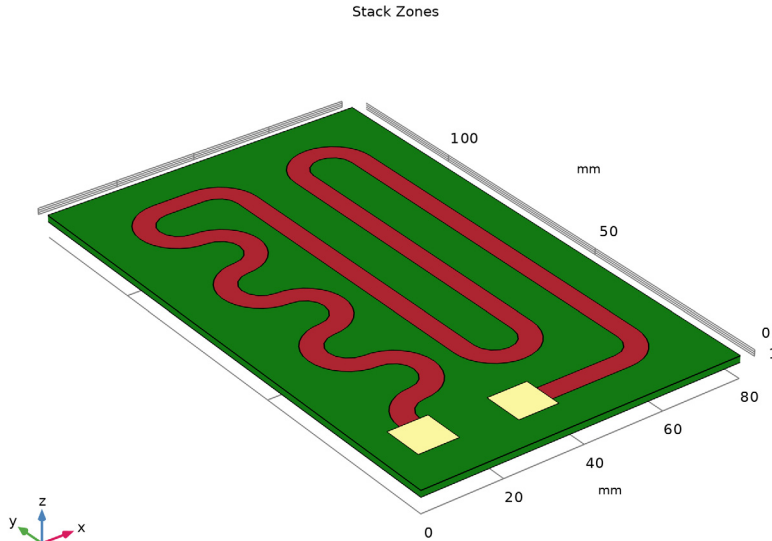

Figure 3: Layered shell version of the model geometry.

The layered shell geometry has many zones with layers of different materials and thicknesses. The spatial position of the different zones can be seen in Figure 4 and material and thicknesses for each zone can be seen in Figure 5.

The different zones of the layered shell are by default disconnected. Therefore, continuity conditions connecting layers from neighboring zones are required in all physics interfaces.



*Figure 4: Zones with different layers in the layered shell geometry. The green zone has only glass layer, the red zone has glass and Nichrome layers, and yellow zone has glass and Silver layers.*

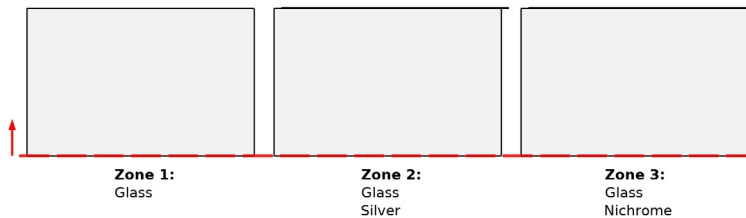

*Figure 5: Cross-sectional view of zones having layers of different material and thickness.*

#### **BOUNDARY CONDITIONS**

During operation the resistive layer produces heat. Model the electrically generated heat using the Electric Currents, Layered Shell interface from the AC/DC Module or the MEMS Module. An electric potential of 12 V is applied to the pads. In the model, you achieve this effect by setting the potential at one edge of the first pad to 12 V, and that of one edge of the other pad to 0 V.

To model the heat transfer in the thin conducting layer, use the Heat Transfer in Shells interface. The heat rate per unit area (measured in  $\text{W}/\text{m}^2$ ) produced inside the thin layer is given by

$$q_{\text{prod}} = dQ_{\text{DC}} \quad (1)$$

where  $Q_{\text{DC}} = \mathbf{J} \cdot \mathbf{E} = \sigma |\nabla_{\mathbf{t}} V|^2$  ( $\text{W}/\text{m}^3$ ) is the power density. The generated heat appears as an inward heat flux at the surface of the glass plate.

At steady state, the resistive layer dissipates the heat it generates in two ways: on its upside to the surrounding air (at 293 K), and on its downside to the glass plate. The glass plate is similarly cooled in two ways: on its circuit side by air, and on its back side by a process fluid (353 K). You model the heat fluxes to the surroundings using heat transfer coefficients,  $h$ . For the heat transfer to air,  $h = 5 \text{ W}/(\text{m}^2 \cdot \text{K})$ , representing natural convection. On the glass plate's back side,  $h = 20 \text{ W}/(\text{m}^2 \cdot \text{K})$ , representing convective heat transfer to the fluid. The sides of the glass plate are insulated.

The model simulates thermal expansion using static structural mechanics analyses. It uses the Layered Shell interface for the glass plate as well as for the circuit layer. The stresses are set to zero at 293 K. You determine the boundary conditions for the Layered Shell interface by adding a rigid motion suppression node and restricting all rigid body modes.

## MATERIAL PROPERTIES

Table 2 summarizes the material properties used in the model.

TABLE 2: MATERIAL PROPERTIES.

MATERIAL	$E$ [GPa]	$\nu$	$\alpha$ [1/K]	$k$ [W/(m·K)]	$\rho$ [kg/m <sup>3</sup> ]	$C_p$ [J/(kg·K)]
Silver	83	0.37	1.89e-5	420	10500	230
Nichrome	213	0.33	1e-5	15	9000	20
Glass	73.1	0.17	5.5e-7	1.38	2203	703

## Results and Discussion

Figure 6 shows the heat that the resistive layer generates.

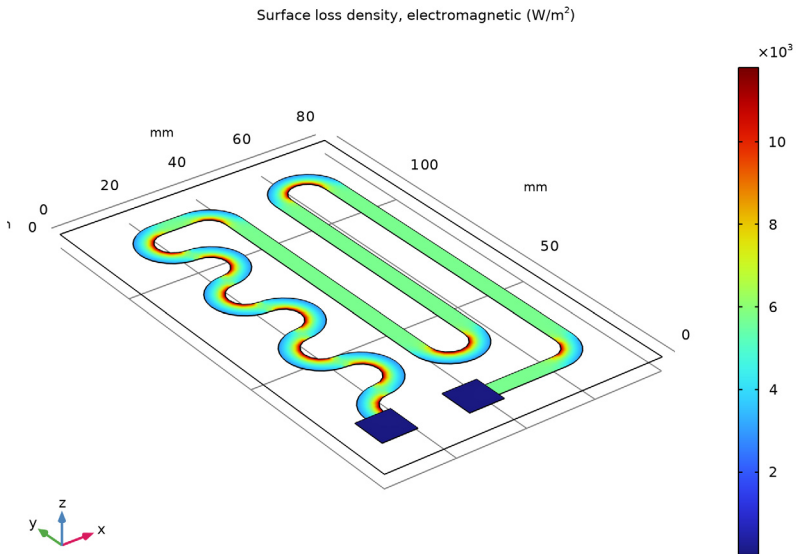

Figure 6: Stationary heat generation in the resistive layer when 12 V is applied.

The highest heating power occurs at the inner corners of the curves due to the higher current density at these spots. The total generated heat, as calculated by integration, is approximately 13.8 W.

Figure 7 shows the temperature of the resistive layer and the glass plate at steady state.

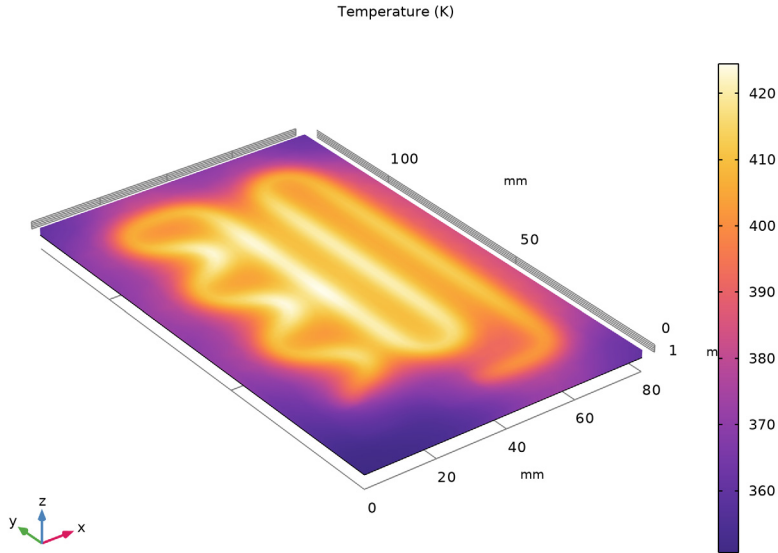
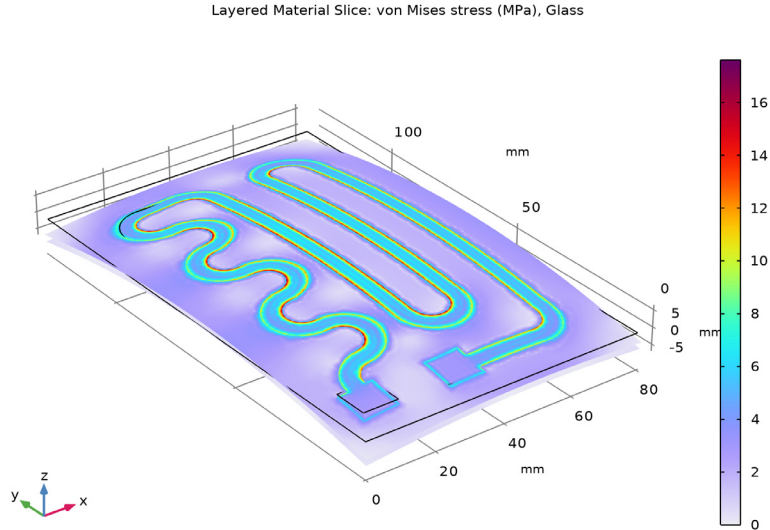

Figure 7: Temperature distribution in the heating device at steady state.

The highest temperature is approximately 424 K, and it appears in the central section of the circuit layer. Interestingly, the temperature differences between the fluid side and the circuit side of the glass plate are quite small because the plate is very thin. Using boundary integration, the integral heat flux on the fluid side evaluates to approximately 8.5 W. This means that the device transfers the majority of the heat it generates 8.5 W out of 13.8 W to the fluid, which is good from a design perspective, although the thermal resistance of the glass plate results in some losses.

The temperature rise also induces thermal stresses due to the materials' different coefficients of thermal expansion. As a result, mechanical stresses and deformations arise in the layer and in the glass plate. Figure 8 and Figure 9 shows the effective stress distribution in the device and the resulting deformations. During operation, the glass plate bends toward the air side.



*Figure 8: The thermally induced von Mises stress plotted with the deformation in glass plate.*

The highest effective stress, approximately 17.5 MPa, occurs at the inner corners of the curves of the Nichrome circuit. The highest effective stress, approximately 380 MPa, occurs in the conducting layer.

Stresses in the interface between the resistive layer and the glass plate must also be considered. Assume that the yield stress of the surface adhesion in the interface is in the region of 50 MPa a value significantly lower than the yield stresses of the other materials in the device. If the effective stress increases above this value, the resistive layer locally detaches from the glass. Once it has detached, heat transfer is locally impeded, which can lead to overheating of the resistive layer and eventually cause the device to fail.

Layered Material Slice: von Mises stress (MPa), Conducting Layer

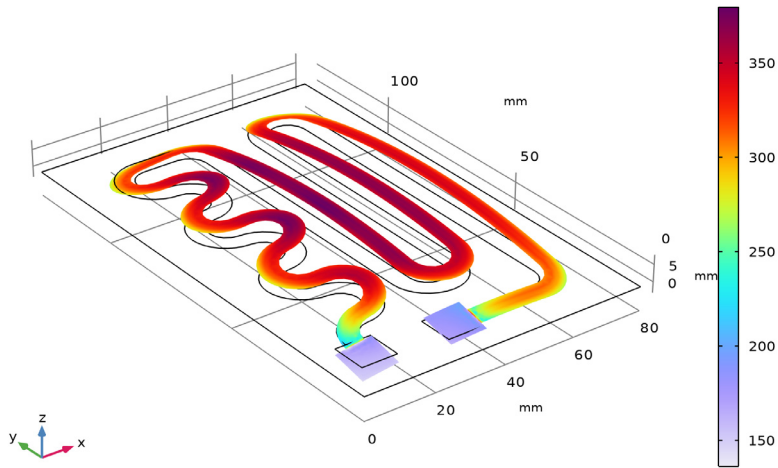
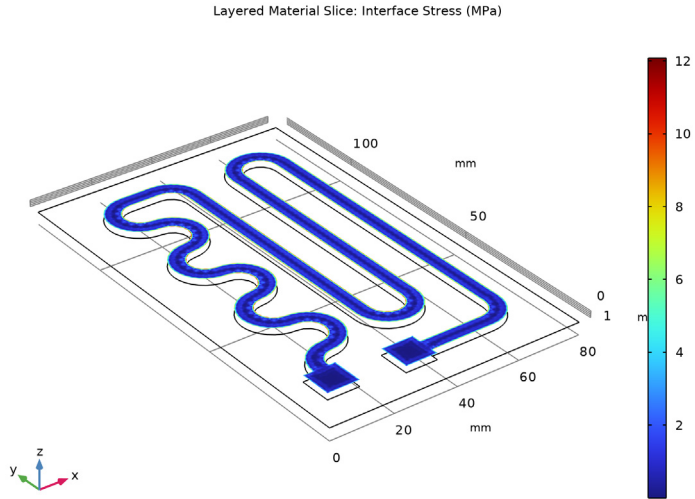

Figure 9: The thermally induced von Mises stress plotted with the deformation in resistive layer.

Figure 10 displays the interface stress acting on the adhesive layer during heater operation. As the figure shows, the device experiences a maximum interfacial stress that is approximately five times smaller than the yield stress. This means that the device is safe in terms of the adhesive stress.

Finally, the warping of the device, that is, its deviation from a plane surface as shown in Figure 11 are studied. The maximum deviation from being a planar surface, is approximately  $48 \mu\text{m}$ . For high-precision applications, such as semiconductor processing, this might be a significant value that limits the device's operating temperature.



*Figure 10: The stress in the interface between the resistive layer and the glass plate.*

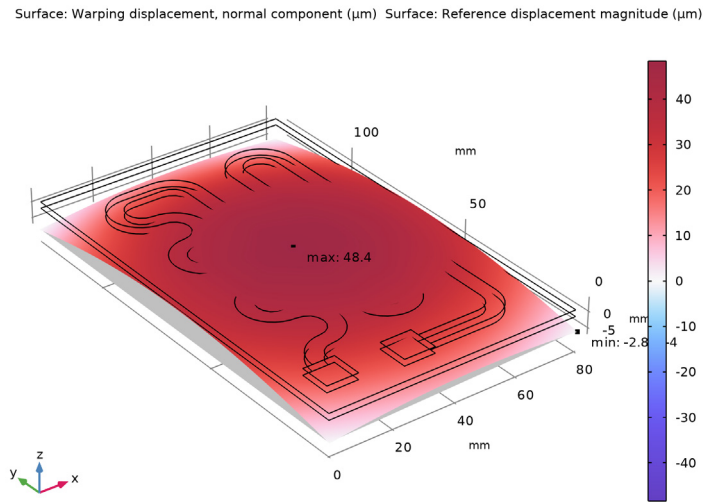

*Figure 11: Deviation from a plane surface on the fluid side of the glass plate.*

## *Notes About the COMSOL Implementation*

---

- Modeling a composite laminate as a layered shell requires a surface geometry, in general referred to as a base surface, and a **Layered Material** node which adds an extra dimension (1D) to the base surface geometry in the surface normal direction. You can use the **Layered Material** functionality to model several layers stacked on top of each other having different thicknesses, material properties, and fiber orientations. You can optionally specify the interface materials between the layers, and control the number of through-thickness mesh elements for each layer.
- The third direction for the selected coordinate system in the **Single Layer Material**, **Layered Material Link**, or **Layered Material Stack** represents the normal direction of the **Layered Shell** or **Shell** physics. This is also the direction in which the layer stacking is interpreted from bottom to top, and therefore, it is crucial to know it during modeling. There are two ways to achieve this:
  - Using physics symbols: Go to the physics settings, find the **Physics Symbols** section, and select the **Enable physics symbols** checkbox. Then go to the material feature, for instance, **Linear Elastic Material**, to see the normal direction represented by green arrows in the geometry.
  - Using result templates: When a solution dataset is available, use the result template **Thickness and Orientation** to plot the normal direction.
- The **Thermal Stress**, **Layered Shell** multiphysics interface includes the **Heat Transfer in Shell** and the **Layered Shell** interfaces. In the silica glass, these two interfaces solve for temperature and displacements, respectively. In the conducting layer representing the circuit, the temperature, electric potential, and displacement are solved by **Heat Transfer in Shell**, **Electric Currents in Layered Shells**, and the **Layered Shell** interfaces.

---

**Application Library path:** Composite\_Materials\_Module/Multiphysics/heating\_circuit\_layered

---

## *Modeling Instructions*



---

From the **File** menu, choose **New**.

### **NEW**

In the **New** window, click  **Model Wizard**.

## MODEL WIZARD

- 1 In the **Model Wizard** window, click  **3D**.
- 2 In the **Select Physics** tree, select **Structural Mechanics > Thermal–Structure Interaction > Thermal Stress, Layered Shell**.
- 3 Click **Add**.
- 4 In the **Select Physics** tree, select **AC/DC > Electric Fields and Currents > Electric Currents in Layered Shells (ecis)**.
- 5 Click **Add**.
- 6 Click  **Study**.
- 7 In the **Select Study** tree, select **General Studies > Stationary**.
- 8 Click  **Done**.

## GLOBAL DEFINITIONS

### *Parameters 1*

Load the parameters from a file.

- 1 In the **Model Builder** window, under **Global Definitions** click **Parameters 1**.
- 2 In the **Settings** window for **Parameters**, locate the **Parameters** section.
- 3 Click  **Load from File**.
- 4 Browse to the model's Application Libraries folder and double-click the file `heating_circuit_layered_parameters.txt`.

## GEOMETRY 1

- 1 In the **Model Builder** window, under **Component 1 (comp1)** click **Geometry 1**.
- 2 In the **Settings** window for **Geometry**, locate the **Units** section.
- 3 From the **Length unit** list, choose **mm**.

### *Work Plane 1 (wp1)*

- 1 In the **Geometry** toolbar, click  **Work Plane**.
- 2 In the **Settings** window for **Work Plane**, click  **Go to Plane Geometry**.

### *Work Plane 1 (wp1) > Plane Geometry*

In the **Model Builder** window, click **Plane Geometry**.

### *Work Plane 1 (wp1) > Square 1 (sq1)*



- 1 In the **Work Plane** toolbar, click  **Square**.
- 2 In the **Settings** window for **Square**, locate the **Size** section.

- 3 In the **Side length** text field, type 10.
- 4 Locate the **Position** section. In the **xw** text field, type 7.
- 5 In the **yw** text field, type 10.
- 6 Click  **Build Selected**.



*Work Plane 1 (wp1) > Square 2 (sq2)*

- 1 Right-click **Component 1 (comp1) > Geometry 1 > Work Plane 1 (wp1) > Plane Geometry > Square 1 (sq1)** and choose **Duplicate**.
- 2 In the **Settings** window for **Square**, locate the **Position** section.
- 3 In the **xw** text field, type 30.
- 4 In the **yw** text field, type 8.
- 5 Click  **Build Selected**.

*Work Plane 1 (wp1) > Polygon 1 (pol1)*

- 1 In the **Work Plane** toolbar, click  **Polygon**.
- 2 In the **Settings** window for **Polygon**, locate the **Coordinates** section.
- 3 From the **Data source** list, choose **File**.
- 4 Click  **Browse**.
- 5 Browse to the model's Application Libraries folder and double-click the file `heating_circuit_layered_polygon.txt`.
- 6 Click  **Build Selected**.

*Work Plane 1 (wp1) > Fillet 1 (fil1)*

- 1 In the **Work Plane** toolbar, click  **Fillet**.
- 2 On the object **pol1**, select Points 2–8, 23–29, 34, 36, 37, 41, and 42 only.  
It might be easier to select the points by using the **Selection List** window. To open this window, navigate to the **Home** toolbar, click **Windows**, and choose **Selection List**. (If you are running the cross-platform desktop, you find **Windows** in the main menu.)
- 3 In the **Settings** window for **Fillet**, locate the **Radius** section.
- 4 In the **Radius** text field, type 10.
- 5 Click  **Build Selected**.

*Work Plane 1 (wp1) > Fillet 2 (fil2)*

- 1 In the **Work Plane** toolbar, click  **Fillet**.
- 2 On the object **fil1**, select Points 6–12, 26–31, 37, 40, 43, 46, 49, and 50 only.
- 3 In the **Settings** window for **Fillet**, locate the **Radius** section.

4 In the **Radius** text field, type 5.

5 Click  **Build Selected**.

*Work Plane 1 (wp1) > Rectangle 1 (r1)*

1 In the **Work Plane** toolbar, click  **Rectangle**.

2 In the **Settings** window for **Rectangle**, locate the **Size and Shape** section.

3 In the **Width** text field, type 80.

4 In the **Height** text field, type 130.

*Form Union (fn)*

In the **Home** toolbar, click  **Build All**.

Before creating layered material stacks, add the materials for individual layers.

#### **ADD MATERIAL**

1 In the **Materials** toolbar, click  **Add Material** to open the **Add Material** window.

2 Go to the **Add Material** window.

3 In the tree, select **Built-in > Silica glass**.

4 Right-click and choose **Add to Global Materials**.

5 In the **Materials** toolbar, click  **Add Material** to close the **Add Material** window.

#### **GLOBAL DEFINITIONS**

*Silica Glass*

In the **Settings** window for **Material**, type Silica Glass in the **Label** text field.

*Silver Layer*

1 In the **Model Builder** window, right-click **Materials** and choose **Blank Material**.

2 Right-click **Material 2 (mat2)** and choose **Rename**.

3 In the **Rename Material** dialog, type Silver Layer in the **New label** text field.

4 Click **OK**.

*Nichrome Layer*

1 In the **Model Builder** window, right-click **Materials** and choose **Blank Material**.

2 Right-click **Material 3 (mat3)** and choose **Rename**.

3 In the **Rename Material** dialog, type Nichrome Layer in the **New label** text field.

4 Click **OK**.

The stacking of the Silver and Nichrome layers is not the same across the glass plate. In order to model the stacking, add a **Layered Material Stack** node with **Layered Material** subnodes having different selections.

## MATERIALS

### *Layered Material Stack 1 (stlmat1)*

In the **Model Builder** window, under **Component 1 (comp1)** right-click **Materials** and choose **Layers > Layered Material Stack**.

### *Layered Material Link 1 (stlmat1.stllmat1)*

In the **Model Builder** window, under **Component 1 (comp1) > Materials > Layered Material Stack 1 (stlmat1)** right-click **Layered Material Link 1 (stlmat1.stllmat1)** and choose **Delete**.

### *Layered Material Stack 1 (stlmat1)*



- 1 In the **Settings** window for **Layered Material Stack**, locate the **Orientation and Position** section.
- 2 From the **Position** list, choose **Bottom side on boundary**.

### *Glass*

- 1 Right-click **Layered Material Stack 1 (stlmat1)** and choose **Layered Material**.
- 2 In the **Settings** window for **Layered Material**, type **Glass** in the **Label** text field.
- 3 Locate the **Layer Definition** section. In the table, enter the following settings:

Layer	Material	Rotation	Value (m)	Thickness	Mesh elements
Layer 1	Silica Glass (mat1)	0.0	0 rad	d_glass	3



### *Silver*

- 1 Right-click **Layered Material Stack 1 (stlmat1)** and choose **Layered Material**.
- 2 In the **Settings** window for **Layered Material**, type **Silver** in the **Label** text field.
- 3 Locate the **Boundary Selection** section. Click  **Clear Selection**.
- 4 Click  **Paste Selection**.
- 5 In the **Paste Selection** dialog, type **2 4** in the **Selection** text field.
- 6 Click **OK**.
- 7 In the **Settings** window for **Layered Material**, locate the **Layer Definition** section.

8 In the table, enter the following settings:

Layer	Material	Rotation	Value (m)	Thickness	Mesh elements
Layer 1	Silver Layer (mat2)	0.0	0 rad	d_layer	1

*Nichrome*

- 1 Right-click **Layered Material Stack 1 (stlmat1)** and choose **Layered Material**.
- 2 In the **Settings** window for **Layered Material**, type Nichrome in the **Label** text field.
- 3 Locate the **Boundary Selection** section. Click  **Clear Selection**.
- 4 Click  **Paste Selection**.
- 5 In the **Paste Selection** dialog, type 3 in the **Selection** text field.
- 6 Click **OK**.
- 7 In the **Settings** window for **Layered Material**, locate the **Layer Definition** section.
- 8 In the table, enter the following settings:

Layer	Material	Rotation	Value (m)	Thickness	Mesh elements
Layer 1	Nichrome Layer (mat3)	0.0	0 rad	d_layer	1

To visualize the stacking, create a **Layer Cross Section Preview** plot through an action button in the **Layered Material Settings** section.

*Layered Material Stack 1 (stlmat1)*

- 1 In the **Model Builder** window, click **Layered Material Stack 1 (stlmat1)**.
- 2 In the **Settings** window for **Layered Material Stack**, click **Layer Cross-Section Preview** in the upper-right corner of the **Layered Material Settings** section. From the menu, choose **Create Layer Cross-Section Plot**.

## RESULTS

*Layer Cross-Section Preview*

- 1 In the **Model Builder** window, expand the **Results** node, then click **Layer Cross-Section Preview**.
- 2 In the **Layer Cross-Section Preview** toolbar, click  **Plot**.

Before adding the material properties, it is a good idea to first set up the physics, so that COMSOL Multiphysics can detect which material properties are needed.

## LAYERED SHELL (LSHELL)

### *Linear Elastic Material 1*

- 1 In the **Model Builder** window, under **Component 1 (comp1) > Layered Shell (lshell)** click **Linear Elastic Material 1**.
- 2 In the **Settings** window for **Linear Elastic Material**, locate the **Linear Elastic Material** section.
- 3 From the **Material symmetry** list, choose **Isotropic**.

### *Rigid Motion Suppression 1*

In the **Physics** toolbar, click  **Boundaries** and choose **Rigid Motion Suppression**.

### *Continuity 1*

- 1 In the **Physics** toolbar, click  **Edges** and choose **Continuity**.
- 2 In the **Settings** window for **Continuity**, locate the **Layer Selection** section.
- 3 From the **Source** list, choose **Layered Material Stack 1 (stlmat1.zone1)**.
- 4 From the **Destination** list, choose **Layered Material Stack 1 (stlmat1.zone2)**.

### *Continuity 2*

- 1 In the **Physics** toolbar, click  **Edges** and choose **Continuity**.
- 2 In the **Settings** window for **Continuity**, locate the **Layer Selection** section.
- 3 From the **Source** list, choose **Layered Material Stack 1 (stlmat1.zone1)**.
- 4 From the **Destination** list, choose **Layered Material Stack 1 (stlmat1.zone3)**.





### *Continuity 3*

- 1 In the **Physics** toolbar, click  **Edges** and choose **Continuity**.
- 2 In the **Settings** window for **Continuity**, locate the **Layer Selection** section.
- 3 From the **Source** list, choose **Layered Material Stack 1 (stlmat1.zone2)**.
- 4 From the **Destination** list, choose **Layered Material Stack 1 (stlmat1.zone3)**.
- 5 In the **Selection** table, enter the following settings:

	<b>Layered material</b>	<b>Offset (m)</b>
√	Layered Material 3	0

The absolute displacement of the glass plate is not important in itself, since it is just a function of how the rigid body constraints are applied. Instead, you want to see how much the boundary deviates from being planar.

### *Warpage 1*

- 1 In the **Physics** toolbar, click  **Boundaries** and choose **Warpage**.
- 2 In the **Settings** window for **Warpage**, locate the **Boundary Selection** section.
- 3 From the **Selection** list, choose **All boundaries**.
- 4 Locate the **Interface Selection** section. From the **Apply to** list, choose **Bottom interface**.
- 5 Locate the **Warpage** section. From the **Reference plane** list, choose **From points**.
- 6 Locate the **Reference Plane, Point 1** section. Click to select the  **Activate Selection** toggle button.
- 7 Select Point 1 only.
- 8 Locate the **Reference Plane, Point 2** section. Click to select the  **Activate Selection** toggle button.
- 9 Select Point 2 only.
- 10 Locate the **Reference Plane, Point 3** section. Click to select the  **Activate Selection** toggle button.
- 11 Select Point 61 only.

## **HEAT TRANSFER IN SHELLS (HTLSH)**

### *Solid 1*

- 1 In the **Model Builder** window, under **Component 1 (comp1)** > **Heat Transfer in Shells (htlsh)** click **Solid 1**.
- 2 In the **Settings** window for **Solid**, locate the **Layer Model** section.
- 3 Clear the **Layerwise constant properties** checkbox.

### *Heat Flux, Interface 1*

- 1 In the **Physics** toolbar, click  **Boundaries** and choose **Heat Flux, Interface**.
- 2 In the **Settings** window for **Heat Flux, Interface**, locate the **Boundary Selection** section.
- 3 From the **Selection** list, choose **All boundaries**.
- 4 Locate the **Interface Selection** section. From the **Apply to** list, choose **Top interface**.
- 5 Locate the **Heat Flux** section. From the **Flux type** list, choose **Convective heat flux**.
- 6 In the  $h$  text field, type  $h_{\text{air}}$ .
- 7 In the  $T_{\text{ext}}$  text field, type  $T_{\text{air}}$ .

### *Heat Flux, Interface 2*

- 1 In the **Physics** toolbar, click  **Boundaries** and choose **Heat Flux, Interface**.

- 2 In the **Settings** window for **Heat Flux, Interface**, locate the **Boundary Selection** section.
- 3 From the **Selection** list, choose **All boundaries**.
- 4 Locate the **Interface Selection** section. From the **Apply to** list, choose **Bottom interface**.
- 5 Locate the **Heat Flux** section. From the **Flux type** list, choose **Convective heat flux**.
- 6 In the  $h$  text field, type `h_fluid`.
- 7 In the  $T_{\text{ext}}$  text field, type `T_fluid`.

#### *Continuity 1*

- 1 In the **Physics** toolbar, click  **Edges** and choose **Continuity**.
- 2 In the **Settings** window for **Continuity**, locate the **Layer Selection** section.
- 3 From the **Source** list, choose **Layered Material Stack 1 (stlmat1.zone1)**.
- 4 From the **Destination** list, choose **Layered Material Stack 1 (stlmat1.zone2)**.

#### *Continuity 2*

- 1 In the **Physics** toolbar, click  **Edges** and choose **Continuity**.
- 2 In the **Settings** window for **Continuity**, locate the **Layer Selection** section.
- 3 From the **Source** list, choose **Layered Material Stack 1 (stlmat1.zone1)**.
- 4 From the **Destination** list, choose **Layered Material Stack 1 (stlmat1.zone3)**.

#### *Continuity 3*

- 1 In the **Physics** toolbar, click  **Edges** and choose **Continuity**.
- 2 In the **Settings** window for **Continuity**, locate the **Layer Selection** section.
- 3 From the **Source** list, choose **Layered Material Stack 1 (stlmat1.zone2)**.
- 4 From the **Destination** list, choose **Layered Material Stack 1 (stlmat1.zone3)**.
- 5 In the **Selection** table, enter the following settings:

	Layered material	Offset (m)
√	Layered Material 3	0

### **ELECTRIC CURRENTS IN LAYERED SHELLS (ECIS)**

- 1 In the **Model Builder** window, under **Component 1 (comp1)** click **Electric Currents in Layered Shells (ecis)**.
- 2 In the **Settings** window for **Electric Currents in Layered Shells**, locate the **Boundary Selection** section.
- 3 In the list box, select **1 (stlmat1)**.
- 4 Click  **Remove from Selection**.

- 5 Select Boundaries 2–4 only.
- 6 Locate the **Shell Properties** section. Clear the **Use all layers** checkbox.
- 7 In the **Selection** table, clear the checkbox for **Layer 1 - Glass**.

#### *Ground 1*

- 1 In the **Physics** toolbar, click  **Edges** and choose **Ground**.
- 2 Select Edge 38 only.
- 3 In the **Settings** window for **Ground**, locate the **Shell Properties** section.
- 4 From the **Layered material** list, choose **Layered Material Stack 1 (stlmat1.zone2)**.

#### *Electric Potential 1*

- 1 In the **Physics** toolbar, click  **Edges** and choose **Electric Potential**.
- 2 Select Edge 5 only.
- 3 In the **Settings** window for **Electric Potential**, locate the **Shell Properties** section.
- 4 From the **Layered material** list, choose **Layered Material Stack 1 (stlmat1.zone2)**.
- 5 Locate the **Electric Potential** section. In the  $V_0$  text field, type  $V_{in}$ .

#### *Electric Continuity 1*

- 1 In the **Physics** toolbar, click  **Edges** and choose **Electric Continuity**.
- 2 In the **Settings** window for **Electric Continuity**, locate the **Layer Selection** section.
- 3 From the **Source** list, choose **Layered Material Stack 1 (stlmat1.zone2)**.
- 4 From the **Destination** list, choose **Layered Material Stack 1 (stlmat1.zone3)**.
- 5 In the **Selection** table, enter the following settings:

	<b>Layered material</b>	<b>Offset (m)</b>
√	Layered Material 3	0

## **MULTIPHYSICS**

#### *Electromagnetic Heating, Layered Shell 1 (ehls1)*

In the **Physics** toolbar, click  **Multiphysics Couplings** and choose **Boundary > Electromagnetic Heating, Layered Shell**.

## **GLOBAL DEFINITIONS**

#### *Silver Layer (mat2)*

- 1 In the **Model Builder** window, under **Global Definitions > Materials** click **Silver Layer (mat2)**.

- 2 In the **Settings** window for **Material**, locate the **Material Contents** section.
- 3 In the table, enter the following settings:

Property	Variable	Value	Unit	Property group
Young's modulus	E	83e9	Pa	Young's modulus and Poisson's ratio
Poisson's ratio	nu	0.37	l	Young's modulus and Poisson's ratio
Density	rho	10500	kg/m <sup>3</sup>	Basic
Thermal conductivity	k_iso ; kii = k_iso, kij = 0	420	W/(m·K)	Basic
Heat capacity at constant pressure	Cp	230	J/(kg·K)	Basic
Electric conductivity	sigma_iso ; sigma_ii = sigma_iso, sigma_ij = 0	sigma_si lver	S/m	Basic
Relative permittivity	epsilon_r_iso ; epsilon_rii = epsilon_r_iso, epsilon_r_ij = 0	1	l	Basic
Coefficient of thermal expansion	alpha_iso ; alpha_ii = alpha_iso, alpha_ij = 0	18.9e-6	l/K	Basic

#### *Nichrome Layer (mat3)*

- 1 In the **Model Builder** window, click **Nichrome Layer (mat3)**.
- 2 In the **Settings** window for **Material**, locate the **Material Contents** section.

3 In the table, enter the following settings:

Property	Variable	Value	Unit	Property group
Young's modulus	E	213e9	Pa	Young's modulus and Poisson's ratio
Poisson's ratio	nu	0.33	l	Young's modulus and Poisson's ratio
Density	rho	9000	kg/m <sup>3</sup>	Basic
Thermal conductivity	k_iso ; kii = k_iso, kij = 0	15	W/(m·K)	Basic
Heat capacity at constant pressure	Cp	20	J/(kg·K)	Basic
Electric conductivity	sigma_iso ; sigma_ii = sigma_iso, sigma_ij = 0	sigma_nic hrome	S/m	Basic
Relative permittivity	epsilon_r_iso ; epsilon_rii = epsilon_r_iso, epsilon_r_ij = 0	1	l	Basic
Coefficient of thermal expansion	alpha_iso ; alpha_ii = alpha_iso, alpha_ij = 0	10e-6	l/K	Basic



## MESH 1

### Free Triangular 1

- 1 In the **Mesh** toolbar, click  **More Generators** and choose **Free Triangular**.
- 2 In the **Settings** window for **Free Triangular**, locate the **Boundary Selection** section.
- 3 From the **Selection** list, choose **All boundaries**.

### Size 1

- 1 Right-click **Free Triangular 1** and choose **Size**.
- 2 In the **Settings** window for **Size**, locate the **Geometric Entity Selection** section.

- 3 In the list box, select **I**.
- 4 Click  **Remove from Selection**.
- 5 Select Boundaries 2–4 only.
- 6 Locate the **Element Size** section. Click the **Custom** button.
- 7 Locate the **Element Size Parameters** section.
- 8 Select the **Maximum element size** checkbox. In the associated text field, type 2.
- 9 Click  **Build All**.

## STUDY I



Switch off the generation of default plots in the study. We will use **Result Templates**.

- 1 In the **Model Builder** window, click **Study I**.
- 2 In the **Settings** window for **Study**, locate the **Study Settings** section.
- 3 Clear the **Generate default plots** checkbox.
- 4 In the **Study** toolbar, click  **Compute**.

Set default units for result presentation.

## RESULTS

### *Preferred Units I*

- 1 In the **Results** toolbar, click  **Configurations** and choose **Preferred Units**.
- 2 In the **Settings** window for **Preferred Units**, locate the **Units** section.
- 3 Click  **Add Physical Quantity**.
- 4 In the **Physical Quantity** dialog, select **General > Displacement (m)** in the tree.
- 5 Click **OK**.
- 6 In the **Settings** window for **Preferred Units**, locate the **Units** section.
- 7 In the table, enter the following settings:

Quantity	Unit	Preferred unit
Displacement	m	μm

- 8 Click  **Add Physical Quantity**.
- 9 In the **Physical Quantity** dialog, select **Solid Mechanics > Stress tensor (N/m<sup>2</sup>)** in the tree.
- 10 Click **OK**.
- 11 In the **Settings** window for **Preferred Units**, locate the **Units** section.

12 In the table, enter the following settings:

Quantity	Unit	Preferred unit
Stress tensor	N/m <sup>2</sup>	MPa

13 Select the **Apply conversions to expressions with the same dimensions** checkbox.

14 Click  **Apply**.

## RESULT TEMPLATES

- 1 In the **Home** toolbar, click  **Windows** and choose **Result Templates**.
- 2 Go to the **Result Templates** window.
- 3 In the tree, select **Study 1/Solution 1 (sol1) > Layered Shell > von Mises Stress (lshell)**.
- 4 Click the **Add Result Template** button in the window toolbar.
- 5 In the tree, select **Study 1/Solution 1 (sol1) > Layered Shell > Stress, Slice (lshell)**.
- 6 Click the **Add Result Template** button in the window toolbar.

## RESULTS

### *Stress, Assembly (lshell)*

- 1 In the **Settings** window for **3D Plot Group**, type **Stress, Assembly (lshell)** in the **Label** text field.
- 2 In the **Stress, Assembly (lshell)** toolbar, click  **Plot**.

### *Stress, Glass (lshell)*

- 1 In the **Model Builder** window, under **Results** click **Stress, Slice (lshell)**.
- 2 In the **Settings** window for **3D Plot Group**, type **Stress, Glass (lshell)** in the **Label** text field.
- 3 Click to expand the **Title** section. From the **Title type** list, choose **Manual**.
- 4 In the **Title** text area, type **Layered Material Slice: von Mises stress (MPa), Glass**.

### *Layered Material Slice 1*

- 1 In the **Model Builder** window, expand the **Stress, Glass (lshell)** node, then click **Layered Material Slice 1**.
- 2 In the **Settings** window for **Layered Material Slice**, locate the **Expression** section.
- 3 In the **Expression** text field, type **lshell.misesGp**.

- 4 Locate the **Through-Thickness Location** section. From the **Location definition** list, choose **Physical**.
- 5 In the **Local z-coordinate** text field, type 0 d\_glass.
- 6 In the **Stress, Glass (Ishell)** toolbar, click  **Plot**.

*Stress, Conducting Layer (Ishell)*

- 1 In the **Model Builder** window, right-click **Stress, Glass (Ishell)** and choose **Duplicate**.
- 2 In the **Model Builder** window, click **Stress, Glass (Ishell) I**.
- 3 In the **Settings** window for **3D Plot Group**, type Stress, Conducting Layer (Ishell) in the **Label** text field.
- 4 Locate the **Title** section. In the **Title** text area, type Layered Material Slice: von Mises stress (MPa), Conducting Layer.

*Layered Material Slice I*

- 1 In the **Model Builder** window, click **Layered Material Slice I**.
- 2 In the **Settings** window for **Layered Material Slice**, locate the **Through-Thickness Location** section.
- 3 In the **Local z-coordinate** text field, type d\_glass+d\_layer.
- 4 In the **Stress, Conducting Layer (Ishell)** toolbar, click  **Plot**.

**RESULT TEMPLATES**

- 1 Go to the **Result Templates** window.
- 2 In the tree, select **Study I/Solution I (sol1) > Heat Transfer in Shells > Temperature, Shell (htlsh)**.
- 3 Click the **Add Result Template** button in the window toolbar.
- 4 In the tree, select **Study I/Solution I (sol1) > Electric Currents in Layered Shells > Electric Potential (ecis)**.
- 5 Click the **Add Result Template** button in the window toolbar.
- 6 In the **Home** toolbar, click  **Windows** and choose **Result Templates**.

**RESULTS**

*Temperature, Shell (htlsh)*

- 1 In the **Model Builder** window, under **Results** click **Temperature, Shell (htlsh)**.
- 2 In the **Temperature, Shell (htlsh)** toolbar, click  **Plot**.

### Surface 1

- 1 In the **Model Builder** window, expand the **Electric Potential (ecis)** node, then click **Surface 1**.
- 2 In the **Settings** window for **Surface**, locate the **Expression** section.
- 3 In the **Expression** text field, type `ecis.Vc`.
- 4 In the **Electric Potential (ecis)** toolbar, click  **Plot**.

### RESULT TEMPLATES

- 1 Go to the **Result Templates** window.
- 2 In the tree, select **Study 1/Solution 1 (sol1) > Layered Shell > Geometry and Layout (Ishell) > Shell Geometry (Ishell)**.
- 3 Click the **Add Result Template** button in the window toolbar.
- 4 In the **Results** toolbar, click  **Result Templates** to close the **Result Templates** window.

### RESULTS

#### Stack Zones

- 1 In the **Model Builder** window, right-click **Shell Geometry (Ishell)** and choose **Duplicate**.
- 2 Drag and drop **Shell Geometry (Ishell) 1** below **Layer Cross-Section Preview**.
- 3 In the **Settings** window for **3D Plot Group**, type **Stack Zones** in the **Label** text field.

#### Surface 1

- 1 In the **Model Builder** window, expand the **Stack Zones** node, then click **Surface 1**.
- 2 In the **Settings** window for **Surface**, click **Replace Expression** in the upper-right corner of the **Expression** section. From the menu, choose **Component 1 (comp1) > Layered materials > Layered Material Stack 1 (stlmat1) > stlmat1.zone - Zone index - 1**.
- 3 Locate the **Coloring and Style** section. From the **Coloring** list, choose **Color table**.
- 4 From the **Color table** list, choose **TrafficLight**.
- 5 In the **Stack Zones** toolbar, click  **Plot**.

#### Surface Losses

- 1 In the **Results** toolbar, click  **3D Plot Group**.
- 2 In the **Settings** window for **3D Plot Group**, type **Surface Losses** in the **Label** text field.

#### Surface 1

- 1 In the **Surface Losses** toolbar, click  **Surface**.

- 2 In the **Settings** window for **Surface**, click **Replace Expression** in the upper-right corner of the **Expression** section. From the menu, choose **Component 1 (comp1) > Electric Currents in Layered Shells > Heating and losses > ecis.Qsh - Surface loss density, electromagnetic - W/m<sup>2</sup>**.
- 3 In the **Surface Losses** toolbar, click  **Plot**.

Take the following steps to generate a plot of the norm of the surface traction vector in the surface plane.

#### *Interface Stress*

- 1 In the **Results** toolbar, click  **3D Plot Group**.
- 2 In the **Settings** window for **3D Plot Group**, type **Interface Stress** in the **Label** text field.
- 3 Locate the **Title** section. From the **Title type** list, choose **Manual**.
- 4 In the **Title** text area, type **Layered Material Slice: Interface Stress (MPa)**.

#### *Layered Material Slice 1*



- 1 In the **Interface Stress** toolbar, click  **More Plots** and choose **Layered Material Slice**.
- 2 In the **Settings** window for **Layered Material Slice**, locate the **Expression** section.
- 3 In the **Expression** text field, type  $\sqrt{1shell.sxz^2+1shell.syz^2}$ .
- 4 Locate the **Through-Thickness Location** section. From the **Location definition** list, choose **Physical**.
- 5 In the **Local z-coordinate** text field, type **d\_glass**.

#### *Selection 1*

- 1 Right-click **Layered Material Slice 1** and choose **Selection**.
- 2 Select Boundaries 2–4 only.
- 3 In the **Interface Stress** toolbar, click  **Plot**.

Next, plot the glass plate's deviation from being plane.

### **RESULT TEMPLATES**

- 1 In the **Results** toolbar, click  **Result Templates** to open the **Result Templates** window.
- 2 Go to the **Result Templates** window.
- 3 In the tree, select **Study 1/Solution 1 (sol1) > Layered Shell > Warpage (wrp1)**.
- 4 Click the **Add Result Template** button in the window toolbar.
- 5 In the **Results** toolbar, click  **Result Templates** to close the **Result Templates** window.

## RESULTS

### *Warpage (wrp1)*

In the **Warpage (wrp1)** toolbar, click  **Plot**.

To calculate the values for the total generated heat and the integrated heat flux on the fluid side, perform a boundary integration. Before creating evaluation group, add a **Layered Material** dataset with evaluation set on interfaces.

### *Layered Material 1a*

- 1 In the **Model Builder** window, expand the **Results > Datasets** node.
- 2 Right-click **Layered Material** and choose **Duplicate**.
- 3 In the **Settings** window for **Layered Material**, locate the **Layers** section.
- 4 From the **Evaluate in** list, choose **Interfaces**.

### *Total Heat Generated*

- 1 In the **Results** toolbar, click  **Evaluation Group**.
- 2 In the **Settings** window for **Evaluation Group**, type Total Heat Generated in the **Label** text field.
- 3 Locate the **Data** section. From the **Dataset** list, choose **Layered Material 1a**.

### *Surface Integration 1*

- 1 Right-click **Total Heat Generated** and choose **Integration > Surface Integration**.
- 2 Select Boundaries 2–4 only.
- 3 In the **Settings** window for **Surface Integration**, locate the **Through-Thickness Location** section.
- 4 From the **Location input** list, choose **Manual**.
- 5 From the **Location definition** list, choose **Physical**.
- 6 Click **Replace Expression** in the upper-right corner of the **Expressions** section. From the menu, choose **Component 1 (comp1) > Electric Currents in Layered Shells > Heating and losses > ecis.Qsh - Surface loss density, electromagnetic - W/m<sup>2</sup>**.
- 7 In the **Total Heat Generated** toolbar, click  **Evaluate**.

The result should be close to 13.8 W.

### *Total Heat Transferred to Fluid*

- 1 In the **Results** toolbar, click  **Evaluation Group**.
- 2 In the **Settings** window for **Evaluation Group**, type Total Heat Transferred to Fluid in the **Label** text field.

- 3 Locate the **Data** section. From the **Dataset** list, choose **Layered Material Ia**.

*Surface Integration I*

- 1 Right-click **Total Heat Transferred to Fluid** and choose **Integration > Surface Integration**.
- 2 In the **Settings** window for **Surface Integration**, locate the **Selection** section.
- 3 From the **Selection** list, choose **All boundaries**.
- 4 Click **Replace Expression** in the upper-right corner of the **Expressions** section. From the menu, choose **Component I (comp1) > Heat Transfer in Shells > Boundary fluxes > ht1sh.hfi2.q0 - Boundary convective heat flux - W/m<sup>2</sup>**.
- 5 In the **Total Heat Transferred to Fluid** toolbar, click  **Evaluate**.

The result should be close to 8.5 W.