



Model created in COMSOL Multiphysics 6.4

Micromechanics of Failure: Multiscale Analysis of a Composite Structure

Introduction

The use of fiber composites ranges from the transportation and energy sectors to the consumer industry. Compared to traditional monolithic materials, fiber composites offer various properties suitable for tailor-made applications. Along with macroscale analyses, structural composites need microscale stress and failure analyses to identify the critical constituents in laminate structures.

Composites can be analyzed at both macro or micro scales, and either analysis has its benefits and limitations. Analyses at both macro and micro scales, so-called multiscale analyses, offer an in-depth insight into the composite structure as well as its constituents' response and help to study the micromechanics of failure based on the global scale loading.

Full multiscale analysis which involves macro analysis with micro analysis at each material point is computationally expensive. In this example, instead of carrying out a micro-level analysis at each material point, the microscale analysis is performed on a few critical material points that are near to failure or have stress concentrations according to the macro-level analysis.

The continuum-based, composite-specific failure theories are useful and give satisfactory results in many situations. However, composite structures used in critical applications may demand a more accurate prediction of failure. This is possible when the mechanics-based failure theories are applied at micro level for individual constituents. [Ref. 2](#) provides the details of micromechanical failure.

In reality, the constituents for unidirectional composites are fiber, matrix, and the interface between them. For simplicity, the interface is often ignored for a micromechanical analysis. In this example, all three constituents are considered.



Read more about the Composite Materials Module in the COMSOL blog, [Introduction to the Composite Materials Module](#).

Model Definition

In this model three different types of analyses are performed:

- A micromechanical analysis to predict the homogenized material properties

- A macromechanical analysis using layerwise theory to get the global response for given load and boundary conditions
- A new micromechanical analysis to predict the local stress field and failure risk based on the average strains computed in the macro-level analysis

MICROMECHANICAL ANALYSIS (MATERIAL PROPERTIES)

A micromechanics analysis of a unidirectional repeating unit cell (RUC) is performed to obtain its homogenized material properties. The composite layer is assumed to be made of carbon fibers unidirectionally embedded in epoxy resin. Between fiber and matrix a thin interface is assumed. A RUC having a cylindrical fiber located at the middle of matrix is shown in [Figure 1](#). The fiber radius is computed assuming a fiber volume fraction of 0.6.

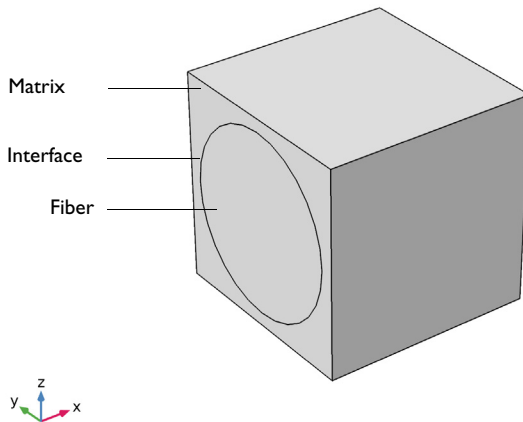

Figure 1: Geometry of the unit cell with a carbon fiber, a thin interface and an epoxy matrix.

Fiber, Interface, and Matrix Properties

The layers of the laminate are made of T300 carbon fiber, epoxy resin, and a custom interface material. The carbon fiber is assumed to be transversely isotropic. The interface material and epoxy resin are assumed to be isotropic. The fiber and matrix materials are taken from built-in **Composites** material library and their material properties are given in [Table 1](#) and [Table 2](#), respectively.

We have assumed certain material properties and the thickness for the interface material based on the discussion in [Ref. 1](#). According to [Ref. 1](#), for fiber composite materials, the interface, or more precisely the interfacial zone, consists of near-surface layers of fiber and

matrix and any layer(s) of material existing between these surfaces. Very weak or very strong interfaces are detrimental to the overall performance of the composite. Hence, an interface with optimal strength is preferred to enhance the performance. With these points in mind, this model assumes elastic properties of the interface that are not as strong as fiber nor as weak as matrix. The interface material properties are based on the discussion in [Ref. 1](#).

TABLE 1: CARBON FIBER MATERIAL PROPERTIES.

Material property	Value
$\{E_1, E_2\}$	{230, 15} GPa
G_{12}	27 GPa
$\{\nu_{12}, \nu_{23}\}$	{0.2, 0.0714}
ρ	1760 kg/m ³

TABLE 2: EPOXY RESIN MATERIAL PROPERTIES.

Material property	Value
E	3.25 GPa
ν	0.265
ρ	1250 kg/m ³

TABLE 3: INTERFACE MATERIAL PROPERTIES.

Material property	Value
E	100 GPa
ν	0.2
ρ	1400 kg/m ³

Thin Layer

The interface between fiber and matrix is not modeled explicitly but considered implicitly using the **Thin Layer** node in the **Solid Mechanics** interface. The feature has a **Linear Elastic Material** node that models the elastic behavior of the interface. The thin layer affects the homogenized material properties as well as the local stress distribution.

Cell Periodicity

To perform a micromechanics analysis, the **Cell Periodicity** node in the **Solid Mechanics** interface is used. The **Cell Periodicity** node is used to apply periodic boundary conditions on three pairs of faces of the unit cell.

To extract the homogenized elasticity matrix for a layer, the unit cell needs to be analyzed for six different load cases. The **Average Strain** periodicity type needs to be selected to obtain the homogenized elasticity matrix. This is automatically done with the help of the

action buttons in the **Cell Periodicity** node. The **Cell Periodicity** node has three action buttons in the toolbar of the **Periodicity Type** section: **Create Load Groups and Study**, **Create Material by Value**, and **Create Material by Reference**. The action button **Create Load Groups and Study** generates six different load groups and a stationary study with six load cases. The action button **Create Material by Reference** generates a **Global Material** with an elasticity matrix corresponding to that of the homogenized material, where properties are in terms of variables. The action button **Create Material by Value** generates a **Global Material** with an elasticity matrix corresponding to that of the homogenized material, where properties are in number format. The generated global material can be used to define the properties of individual layers in a composite laminate.

MACROMECHANICAL ANALYSIS (GLOBAL RESPONSE)

Layerwise (LW) Theory

In the Layerwise theory, the degrees of freedom are the displacements (u, v, w) available on the reference surface (or modeled surface) as well as in the through-thickness direction. From a constitutive equation point of view, this theory is similar to 3D solid elasticity. The layerwise theory is useful for detailed modeling of thick composite laminates because it can capture interlaminar shear stresses. It could therefore be used to also study delamination.

Geometry and Boundary Conditions

The model represents a composite cylinder with a length of 0.5 m and a radius of 0.1 m. It is shown in [Figure 2](#). The boundary conditions and loading are:

- One end of the cylinder is fixed.
- The other end has a transverse load of 75 kN, represented as a uniform boundary load on cross section.

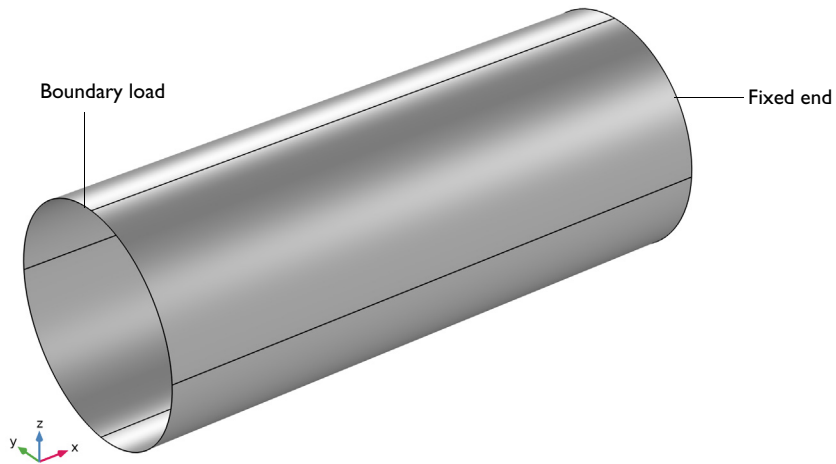

Figure 2: Geometry with boundary conditions and loading.

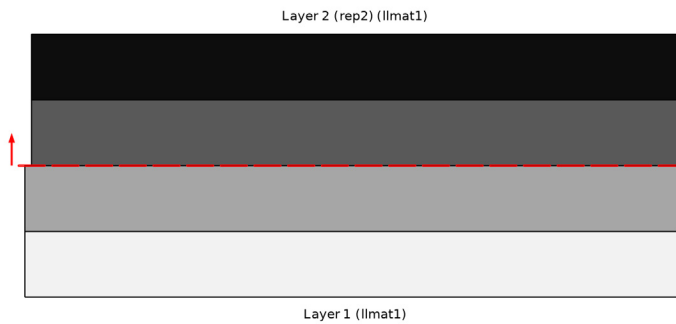

Figure 3: Through-thickness view of the laminated material with four layers.

Stacking Sequence and Material Properties

The laminate consists of four layers of 1 mm thickness, as shown in Figure 3. The orientations of the layers are different; starting from the bottom of the laminate, they are 90, 0, 90, and 0 degrees, as shown in Figure 4. The orientation of a layer is specified with respect to the laminate coordinate system. The material properties for each layer are given by the homogenized material computed in the first micromechanical analysis.

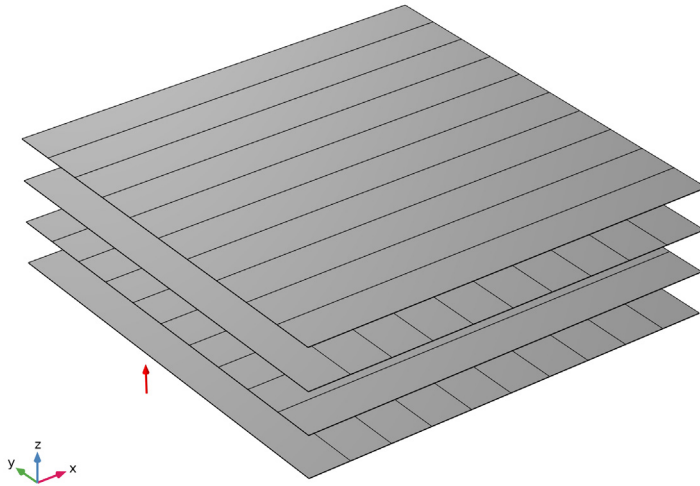

Figure 4: Stacking sequence $[90/0/90/0]$ for the laminate showing the fiber orientation of each layer, from bottom to top.

Failure Criteria

Two composite-specific failure criteria, Hashin and Puck, are used to evaluate the critical regions in the composite cylinder for the given loading condition. These are advanced composite-specific criteria that account for multiaxial states of stress, and different failure

modes for tensile and compressive loading. The failure modes considered by these two criteria are summarized in [Table 4](#).

TABLE 4: FAILURE MODES.

Failure criterion	Failure modes
Hashin	Fiber rupture in tension and shear Fiber buckling in compression Matrix failure in tension and shear Matrix failure in compression and shear Interlaminar failure in tension Interlaminar failure in compression
Puck	Fiber rupture in tension Fiber buckling in compression Matrix failure in tension and in-plane shear (Interfiber failure: Mode A) Matrix failure in compression and in-plane shear (Interfiber failure: Mode B) Matrix failure in compression and in-plane shear (Interfiber failure: Mode C)

The tensile, compressive, and shear strengths of ply are taken from [Ref. 2](#) and are given in [Table 5](#).

TABLE 5: MATERIAL STRENGTHS.

Material strengths	Value
$\{\sigma_{ts1}, \sigma_{ts2}, \sigma_{ts3}\}$	{1500,50,50} MPa
$\{\sigma_{cs1}, \sigma_{cs2}, \sigma_{cs3}\}$	{900,230,230} MPa
$\{\sigma_{ss23}, \sigma_{ss13}, \sigma_{ss12}\}$	{90,90,90} MPa

The Puck criterion needs additional strength properties which are tabled in [Table 6](#).

TABLE 6: ADDITIONAL STRENGTH PROPERTIES

Property	Variable	Value
Ultimate tensile strain, direction	ϵ_{ts1}	0.1
Ultimate compressive strain, direction	ϵ_{cs1}	0.08
Linear degradation stress	σ_{1D}	2000 MPa

MICROMECHANICAL ANALYSIS (LOCAL RESPONSE)

To determine the local response of the constituents to the global loading conditions, the same unit cell geometry and material properties as in the first analysis are used, and the macro-level strains from the second analysis are prescribed. The micromechanical analysis is performed at a few material points, chosen to be where failure or maximum stress occurs in the global analysis.

Failure Criteria

At a micro level, the mechanics-based failure criteria can be used as the constituents are monolithic. These fundamental criteria predict failure more accurately than the global level phenomenological criteria; see [Ref. 2](#).

For the fiber, the Tsai–Wu orthotropic failure criterion is the best suited. For unidirectional composites, the fibers are longitudinally continuous and have higher modulus and strength in the longitudinal direction. Hence, the fibers take the longitudinal tensile and compressive loads. In the transverse direction, the fibers are bonded by the matrix, which plays an important role for the transverse and shear loads. As stated in [Ref. 2](#), if the transverse and shear stresses from the Tsai–Wu orthotropic failure criterion are neglected, the failure criterion for the fiber is reduced to the simple relations

$$-\sigma_{c1} < \sigma_1 < \sigma_{t1}$$

where σ_{i1} is the stress component in the fiber direction and σ_{t1} and σ_{c1} are the tensile and compressive strengths, respectively, of the fiber.

The matrix is isotropic and has different strengths in tension and compression. Theoretical studies and experiments show that the failure of the matrix depends on deviatoric and volumetric stresses. In [Ref. 2](#), the following failure criterion was proposed for the matrix:

$$\frac{\sigma_m^2}{\sigma_t \sigma_c} + \left(\frac{1}{\sigma_t} - \frac{1}{\sigma_c} \right) I_1 - 1 = 0$$

where σ_m is the von Mises stress and I_1 is the first invariant of the stress tensor.

The interface fails primarily because the normal and tangential tractions exceed their strength limits, which results in debonding. In [Ref. 2](#), the following quadratic failure criterion was proposed for the interface:

$$\left(\frac{\langle t_n \rangle}{\sigma_n} \right)^2 + \left(\frac{t_s}{\sigma_s} \right)^2 - 1 = 0$$

where t_n and t_s are normal (perpendicular to the interface boundary) and shear (tangential to the interface boundary) tractions, and σ_n and σ_s are the normal and shear strength, respectively. The angular brackets around the normal traction are *Macauley brackets*, which return the argument if positive and zero otherwise.

The constituent's strength properties are taken from Ref. 2 and given in Table 7.

TABLE 7: CONSTITUENT'S STRENGTH PROPERTIES

Property	Variable	Value
Tensile strength of fiber	σ_{ts1}	2458 MPa
Compressive strength of fiber	σ_{cs1}	1500 MPa
Tensile strength of matrix	σ_{ts}	103 MPa
Compressive strength of matrix	σ_{cs}	265 MPa
Interfacial normal strength of interface	σ_{ns}	60 MPa
Interfacial shear strength of interface	σ_{ss}	180 MPa

Results and Discussion

In the micromechanics analysis, six load cases are used to evaluate the elasticity matrix. The distribution of the effective (von Mises) stress for four of the load cases is shown in Figure 5. From Figure 5 one can see how individual constituents respond to different load cases.

The homogenized material obtained from the first micromechanical analysis is used in the subsequent macromechanical analysis.

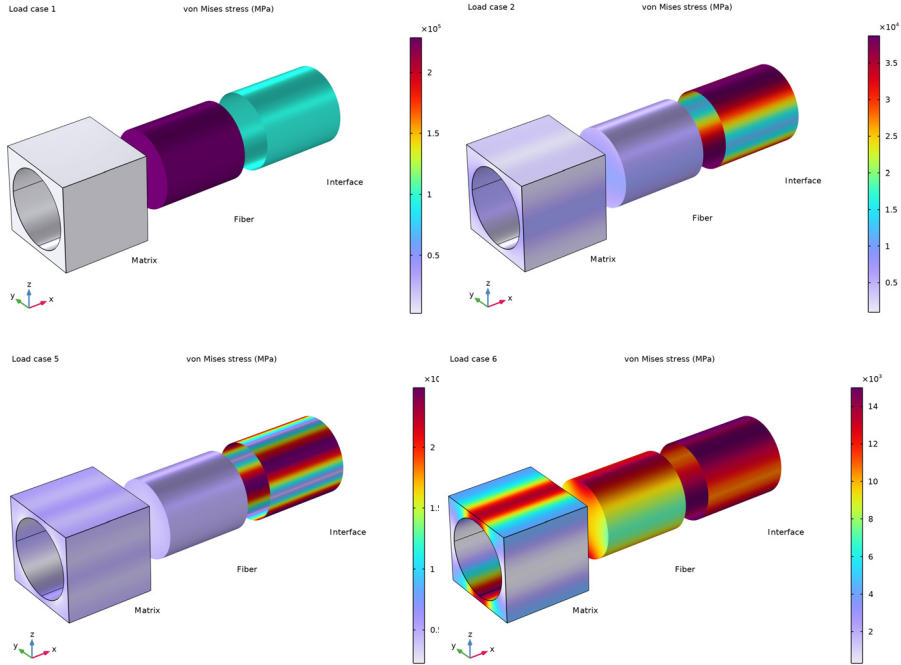

Figure 5: von Mises stress distribution in the unit cell for four load cases.

The stress in the fiber direction in the composite cylinder obtained from the macro-level analysis is presented in [Figure 6](#). Both ends of the cylinder have regions with higher stresses. [Figure 7](#) shows the stress in the fiber direction in five interfaces of the laminate, indicating that the maximum stress occurs at cylinder ends in inner and upper layers. To find the exact location of the maximum stress, a **Surface Maximum** node can be used (for details, see the modeling instructions). Based on this, it is clear that the maximum stress occurs in the outer layer of the laminate toward the fixed end, and in the inner layer toward the loaded end. Both positions where the maximum stress occurs are used for the subsequent micromechanical analysis.

The distributions of the Hashin and Puck failure indexes in the composite cylinder are shown in [Figure 8](#) and [Figure 9](#), respectively. For the Hashin failure criterion, the maximum failure index is at the outer layer toward the loaded end, while for the Puck criterion the maximum failure index is at the second layer from inside toward the loaded end. The puck criterion shows higher failure index even in inner and outer layers. Hence, the material points from inner and outer layers are used for the subsequent

micromechanical analysis. Both failure criteria involve different failure modes, so it is important to check each individual mode's failure indexes. Table 8 shows the maximum failure indexes of the individual failure mode for both failure criteria. The values indicate that for this composite structure, the matrix material would fail in the tension.

TABLE 8: MAXIMUM FAILURE INDEXES OF DIFFERENT FAILURE MODES.

Failure Criterion	Failure Modes	Failure Index
Hashin	Fiber rupture in tension and shear	0.67063
	Fiber buckling in compression	0.93302
	Matrix failure in tension and shear	1.03461
	Matrix failure in compression and shear	0.67062
	Interlaminar failure in tension	$5.6948 \cdot 10^{-5}$
	Interlaminar failure in compression	$1.5818 \cdot 10^{-4}$
Puck	Fiber rupture in tension	0.06035
	Fiber buckling in compression	0.07544
	Matrix failure in tension and in-plane shear (Mode A)	1.00741
	Matrix failure in compression and in-plane shear (Mode B)	0.81894
	Matrix failure in compression and in-plane shear (Mode C)	0.58237

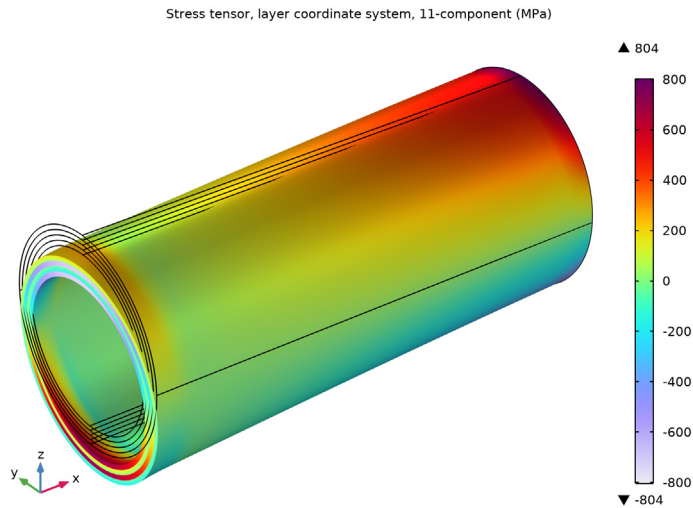

Figure 6: The stress in the fiber direction in the composite laminate.

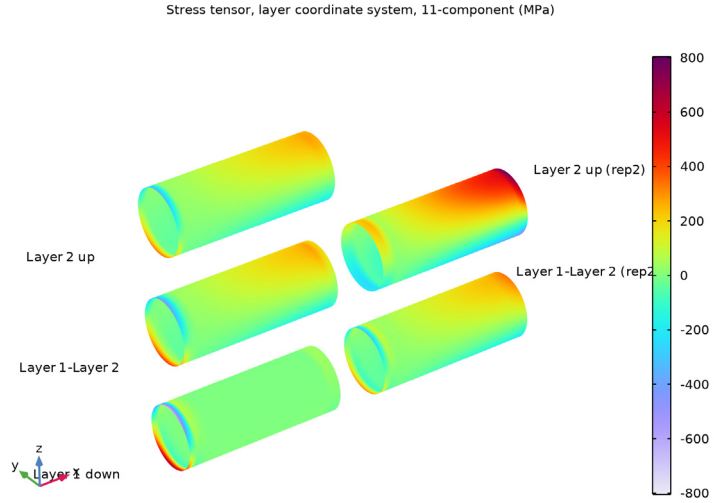

Figure 7: The stress in the fiber direction in the five interfaces of the composite laminate.

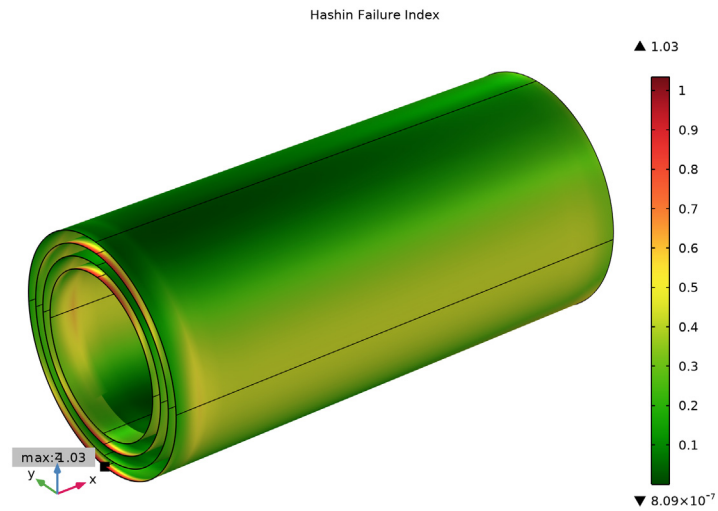

Figure 8: Hashin failure index distribution in the composite laminate.

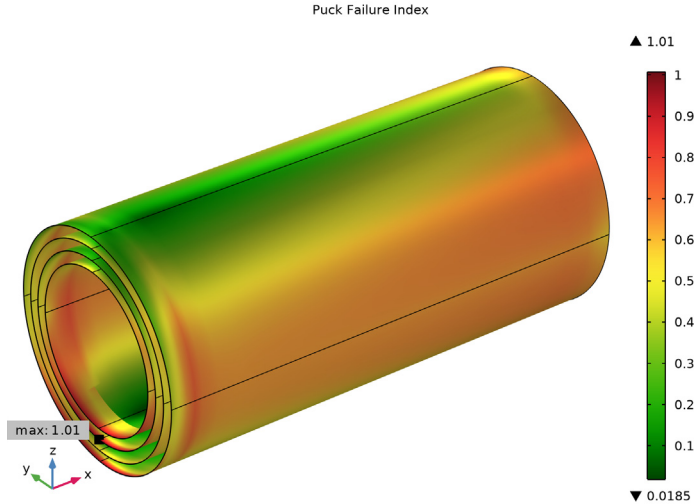

Figure 9: Puck failure index distribution in the composite laminate.

For the second micromechanical analysis, several material locations are selected and macro strains from these locations are prescribed for the unit cell structure to get the local stress and strain fields that are eventually useful to carry out micromechanical failure analysis.

Figure 10 shows the von Mises stress distribution in the constituents at a material point located in the inner layer. It shows that compared to macro stress the micro stress is very high. The stress distribution in the constituents at the various material locations is shown in Figure 11. Based on macromechanical analysis, two critical points one at inner layer and one at outer layer toward loaded end are chosen for subsequent micromechanical analysis. The micromechanical failure analysis is performed at these material points, and the results are presented in Figure 12 and Figure 13. Both figures show that the failure indexes are maximum in the matrix compared to the fiber and interface, which supports the finding based on the macromechanical failure analysis. The micromechanical failure indexes are less than one, indicating that there is no failure in the constituent materials at these critical points. Table 9 shows the maximum values of the failure indexes in the constituents at two

different material locations, which are chosen as critical locations based on the macromechanical analysis.

TABLE 9: MAXIMUM USER DEFINED FAILURE INDEXES IN THE CONSTITUENTS AT DIFFERENT MATERIAL LOCATIONS.

Material Locations	Constituents	Failure Index
Point in the inner layer at bottom of loaded edge	Matrix	0.67705
	Fiber	0.56783
	Interface	$3.41362 \cdot 10^{-4}$
Point in the outer layer at bottom of loaded edge	Matrix	0.77868
	Fiber	0.24251
	Interface	$1.02509 \cdot 10^{-5}$

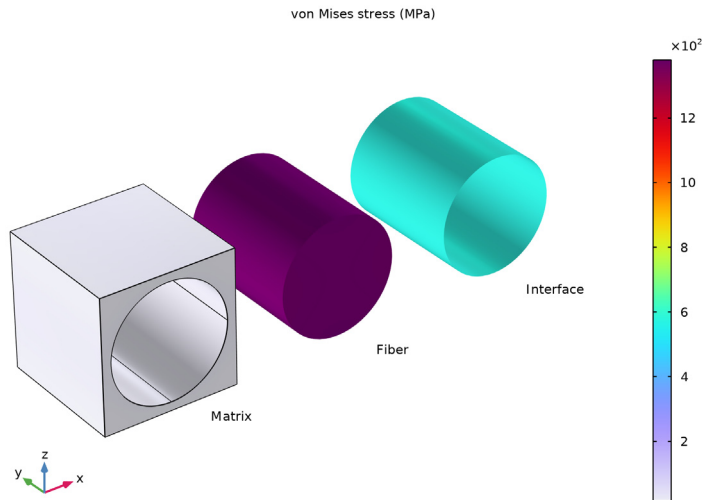

Figure 10: von Mises stress in the constituents at a particular material location of the composite cylinder.

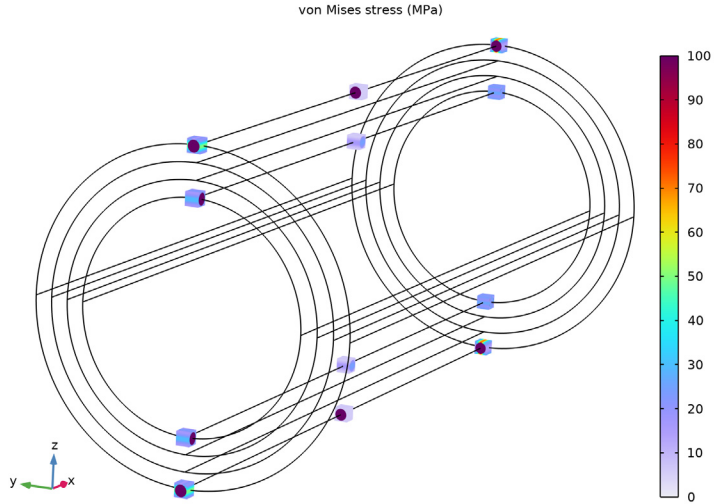

Figure 11: von Mises stress in the constituents at multiple material locations of the composite cylinder.

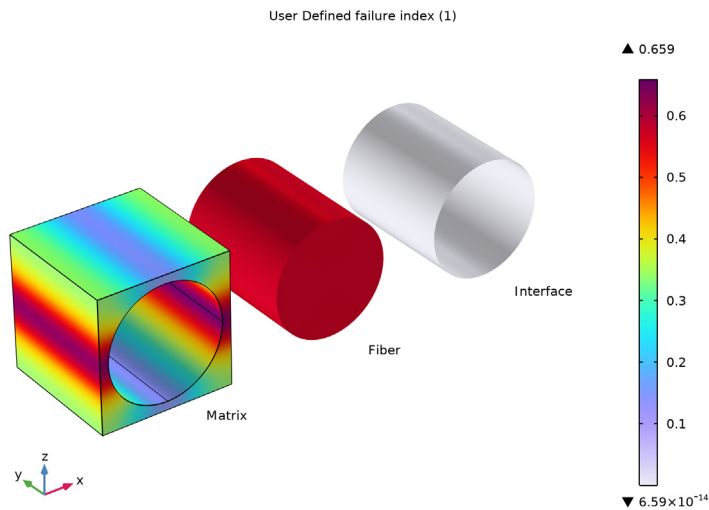

Figure 12: User defined failure indexes in the constituents at a particular material location of the composite cylinder.

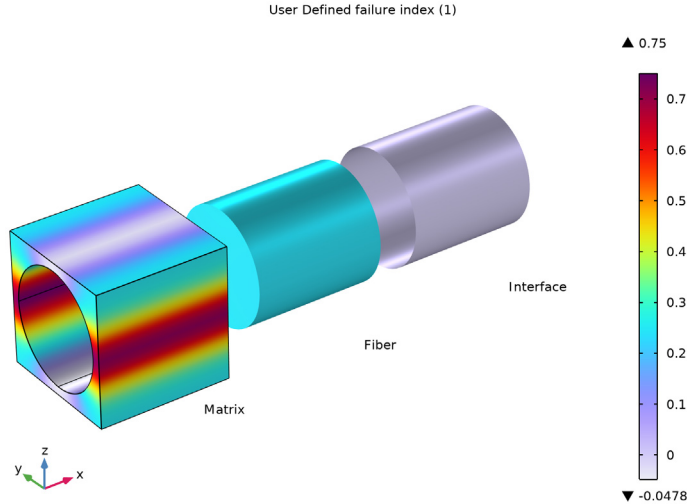

Figure 13: User defined failure indexes in the constituents at a particular material location of the composite cylinder.

Notes About the COMSOL Implementation

- Modeling a composite laminated shell requires a 2D surface geometry, called a base surface, and a **Layered Material** node that adds an extra dimension (1D) to the base surface geometry in the surface normal direction. Using the **Layered Material** functionality, you can model several layers of different thicknesses, material properties, and fiber orientations. You can optionally specify the interface materials between the layers and the control mesh elements in each layer.
- The **Layered Material Link** and **Layered Material Stack** have an option to transform the given **Layered Material** into a symmetric or antisymmetric laminate. A repeated laminate can also be constructed using a transform option.
- through-thickness mesh elements for each layer.
- The third direction for the selected coordinate system in the **Single Layer Material**, **Layered Material Link**, or **Layered Material Stack** represents the normal direction of the **Layered Shell** or **Shell** physics. This is also the direction in which the layer stacking is

interpreted from bottom to top, and therefore, it is crucial to know it during modeling. There are two ways to achieve this:

- Using physics symbols: Go to the physics settings, find the **Physics Symbols** section, and select the **Enable physics symbols** checkbox. Then go to the material feature, for instance, **Linear Elastic Material**, to see the normal direction represented by green arrows in the geometry.
- Using result templates: When a solution dataset is available, use the result template **Thickness and Orientation** to plot the normal direction.
- The built-in **Composites** material library contains data for fiber and matrix constituents as well as for unidirectional and bidirectional laminae.
- To analyze the results in a composite shell, you can either create a slice plot using the **Layered Material Slice** plot for in-plane variation of a quantity, or you can create a **Through Thickness** plot for out-of-plane variation of a quantity at a point. To visualize the results as a 3D solid object, you can use the **Layered Material** dataset, which creates a virtual 3D solid object combining the surface geometry (2D) and the extra dimension (1D).

References

1. K.K. Chawla, *Composite Materials: Science and Engineering*, 4th ed., Springer, 2019.
2. S.K. Ha, K.K. Jin, and Y. Huang, “Micro-Mechanics of Failure (MMF) for Continuous Fiber Reinforced Composites,” *J. Comp. Mat.*, vol. 42, no. 18, pp. 1873–1895, 2008.

Application Library path: Composite_Materials_Module/Tutorials/composite_multiscale

Modeling Instructions (Micromechanics)

From the **File** menu, choose **New**.

NEW

In the **New** window, click  **Model Wizard**.

MODEL WIZARD

1 In the **Model Wizard** window, click  **3D**.

2 In the **Select Physics** tree, select **Structural Mechanics > Solid Mechanics (solid)**.



- 3 Click **Add**.
- 4 Click  **Done**.

GLOBAL DEFINITIONS



Geometric Properties

- 1 In the **Model Builder** window, under **Global Definitions** click **Parameters I**.
- 2 In the **Settings** window for **Parameters**, type Geometric Properties in the **Label** text field.
- 3 Locate the **Parameters** section. Click  **Load from File**.
- 4 Browse to the model's Application Libraries folder and double-click the file `composite_multiscale_parameters.txt`.

Elastic Properties

- 1 In the **Home** toolbar, click  **Parameters** and choose **Add > Parameters**.
- 2 In the **Settings** window for **Parameters**, type Elastic Properties in the **Label** text field.
- 3 Locate the **Parameters** section. Click  **Load from File**.
- 4 Browse to the model's Application Libraries folder and double-click the file `composite_multiscale_material_properties.txt`.

Strength Properties

- 1 In the **Home** toolbar, click  **Parameters** and choose **Add > Parameters**.
- 2 In the **Settings** window for **Parameters**, type Strength Properties in the **Label** text field.
- 3 Locate the **Parameters** section. Click  **Load from File**.
- 4 Browse to the model's Application Libraries folder and double-click the file `composite_multiscale_strength_properties.txt`.
- 5 In the **Model Builder** window, right-click **Global Definitions** and choose **Geometry Parts > Part Libraries**.

PART LIBRARIES

- 1 In the **Part Libraries** window, select **COMSOL Multiphysics > Unit Cells and RVEs > Fiber Composites > unidirectional_fiber_square_packing** in the tree.
- 2 Click  **Add to Model**.
- 3 In the **Select Part Variant** dialog, select **Specify fiber diameter** in the **Select part variant** list.

4 Click **OK**.

COMPONENT: MICROMECHANICS (MATERIAL PROPERTIES)

- 1 In the **Model Builder** window, click **Component 1 (comp1)**.
- 2 In the **Settings** window for **Component**, type Component: Micromechanics (Material Properties) in the **Label** text field.

GEOMETRY 1

Unidirectional Fiber Composite, Square Packing 1 (pi1)

- 1 In the **Geometry** toolbar, click  **Part Instance** and choose **Unidirectional Fiber Composite, Square Packing**.



To customize the unit cell geometry, enter the unit cell parameters in the input parameters of the part.

- 2 In the **Settings** window for **Part Instance**, locate the **Input Parameters** section.
- 3 In the table, enter the following settings:

Name	Expression	Value	Description
df	$2 * r_f$	0.0087404 m	Fiber diameter
wm	1	0.01 m	Cell width
dm	1	0.01 m	Cell depth
hm	1	0.01 m	Cell height

- 4 Locate the **Position and Orientation of Output** section. Find the **Displacement** subsection. In the **xwi** text field, type -0.005[m].
- 5 In the **ywi** text field, type -0.005[m].
- 6 In the **zwi** text field, type -0.005[m].

Form Union (fin)

- 1 In the **Model Builder** window, click **Form Union (fin)**.
- 2 In the **Settings** window for **Form Union/Assembly**, click  **Build Selected**.
- 3 Click the  **Zoom Extents** button in the **Graphics** toolbar.

In order to simplify the modeling process create explicit selections.

Interface Selection

- 1 In the **Geometry** toolbar, click  **Selections** and choose **Explicit Selection**.
- 2 In the **Settings** window for **Explicit Selection**, locate the **Entities to Select** section.

- 3 From the **Geometric entity level** list, choose **Boundary**.
- 4 On the object **fin**, select Boundaries 6–9 only.
- 5 In the **Label** text field, type **Interface Selection**.

SOLID MECHANICS (SOLID)

Linear Elastic Material 1

- 1 In the **Model Builder** window, under **Component: Micromechanics (Material Properties) (comp1) > Solid Mechanics (solid)** click **Linear Elastic Material 1**.
- 2 In the **Settings** window for **Linear Elastic Material**, locate the **Linear Elastic Material** section.
- 3 From the **Material symmetry** list, choose **Orthotropic**.

Add a **Thin Layer** feature to model the interface between the fiber and matrix.

Thin Layer 1

- 1 In the **Physics** toolbar, click  **Boundaries** and choose **Thin Layer**.
- 2 In the **Settings** window for **Thin Layer**, locate the **Boundary Selection** section.
- 3 From the **Selection** list, choose **Interface Selection**.
- 4 Locate the **Boundary Properties** section. In the L_{th} text field, type **th_i**.

Cell Periodicity 1

- 1 In the **Physics** toolbar, click  **Domains** and choose **Cell Periodicity**.
- 2 In the **Settings** window for **Cell Periodicity**, locate the **Periodicity Settings** section.
- 3 From the **Boundary conditions** list, choose **Average strain**.
- 4 Locate the **Effective Properties** section. Select the **Compute density** checkbox.
- 5 Select the **Compute elasticity matrix, standard notation** checkbox.

Boundary Pair 1

- 1 In the **Physics** toolbar, click  **Attributes** and choose **Boundary Pair**.
- 2 In the **Settings** window for **Boundary Pair**, locate the **Boundary Selection** section.
- 3 From the **Selection** list, choose **Pair 1 (Unidirectional Fiber Composite, Square Packing 1)**.

Boundary Pair 2

- 1 Right-click **Boundary Pair 1** and choose **Duplicate**.
- 2 In the **Settings** window for **Boundary Pair**, locate the **Boundary Selection** section.
- 3 From the **Selection** list, choose **Pair 2 (Unidirectional Fiber Composite, Square Packing 1)**.

Boundary Pair 3

- 1 Right-click **Boundary Pair 2** and choose **Duplicate**.
- 2 In the **Settings** window for **Boundary Pair**, locate the **Boundary Selection** section.
- 3 From the **Selection** list, choose **Pair 3 (Unidirectional Fiber Composite, Square Packing 1)**.

In the upper-right corner of the **Periodicity type** section, you can find three buttons: **Create Load Groups and Study**, **Create Material by Reference**, and **Create Material by Value**. When the **Average strain** option is selected for the computation of the elasticity matrix, you can automatically generate load groups, a study, and a material by clicking on these buttons.

Cell Periodicity 1

- 1 In the **Model Builder** window, click **Cell Periodicity 1**.
- 2 In the **Settings** window for **Cell Periodicity**, click **Automated Model Setup** in the upper-right corner of the **Periodicity Settings** section. From the menu, choose **Create Load Groups and Study** to generate load groups and a study node.

COMSOL Multiphysics is equipped with built-in material properties for a number of composite constituents. Select the needed materials from the **Composites** material folder in the built-in material library.

MATERIALS

Material Link 1: Matrix

- 1 In the **Model Builder** window, under **Component: Micromechanics (Material Properties) (comp1)** right-click **Materials** and choose **More Materials > Material Link**.
- 2 In the **Settings** window for **Material Link**, type **Material Link 1: Matrix** in the **Label** text field.
- 3 Locate the **Geometric Entity Selection** section. From the **Selection** list, choose **Matrix (Unidirectional Fiber Composite, Square Packing 1)**.
- 4 Locate the **Link Settings** section. Click  **Add Material from Library**.

ADD MATERIAL TO MATERIAL LINK 1: MATRIX (MATLNK1)

- 1 Go to the **Add Material to Material Link 1: Matrix (matlnk1)** window.
- 2 In the tree, select **Composites > Matrix Constituents > Epoxy polymer**.
- 3 Click **Add Material**.

MATERIALS

Material Link 2: Fiber

- 1 Right-click **Materials** and choose **More Materials > Material Link**.
- 2 In the **Settings** window for **Material Link**, type Material Link 2: Fiber in the **Label** text field.
- 3 Locate the **Geometric Entity Selection** section. From the **Selection** list, choose **Fiber (Unidirectional Fiber Composite, Square Packing I)**.
- 4 Locate the **Link Settings** section. Click  **Add Material from Library**.

ADD MATERIAL TO MATERIAL LINK 2: FIBER (MATLNK2)

- 1 Go to the **Add Material to Material Link 2: Fiber (matlnk2)** window.
- 2 In the tree, select **Composites > Fiber Constituents > T-300 carbon fiber**.
- 3 Click **Add Material**.

MATERIALS

Material Link 3: Interface

- 1 Right-click **Materials** and choose **More Materials > Material Link**.
- 2 In the **Settings** window for **Material Link**, type Material Link 3: Interface in the **Label** text field.
- 3 Locate the **Geometric Entity Selection** section. From the **Geometric entity level** list, choose **Boundary**.
- 4 From the **Selection** list, choose **Interface Selection**.
- 5 Locate the **Link Settings** section. Click  **Blank Material**.

GLOBAL DEFINITIONS

Interface material

- 1 In the **Model Builder** window, under **Global Definitions > Materials** click **Material 3 (mat3)**.
- 2 In the **Settings** window for **Material**, type Interface material in the **Label** text field.
- 3 Locate the **Material Contents** section. In the table, enter the following settings:

Property	Variable	Value	Unit	Property group
Young's modulus	E	E_i	Pa	Young's modulus and Poisson's ratio



Property	Variable	Value	Unit	Property group
Poisson's ratio	nu	nu_i	l	Young's modulus and Poisson's ratio
Density	rho	rho_i	kg/m ³	Basic

MESH 1

Identical Mesh 1

- 1 In the **Mesh** toolbar, click  **More Attributes** and choose **Identical Mesh**.
- 2 In the **Settings** window for **Identical Mesh**, locate the **First Entity Group** section.
- 3 From the **Selection** list, choose **Pair 1, Source (Unidirectional Fiber Composite, Square Packing 1)**.
- 4 Locate the **Second Entity Group** section. From the **Selection** list, choose **Pair 1, Destination (Unidirectional Fiber Composite, Square Packing 1)**.

Free Triangular 1

- 1 In the **Mesh** toolbar, click  **More Generators** and choose **Free Triangular**.
- 2 In the **Settings** window for **Free Triangular**, locate the **Boundary Selection** section.
- 3 From the **Selection** list, choose **Pair 1, Source (Unidirectional Fiber Composite, Square Packing 1)**.
- 4 Click  **Build Selected**.

Swept 1

- 1 In the **Mesh** toolbar, click  **Swept**.
- 2 In the **Settings** window for **Swept**, click  **Build All**.

STUDY: MICROMECHANICS (MATERIAL PROPERTIES)

- 1 In the **Model Builder** window, click **Cell Periodicity Study**.
- 2 In the **Settings** window for **Study**, type Study: Micromechanics (Material Properties) in the **Label** text field.
- 3 In the **Study** toolbar, click  **Compute**.

Set default units for result presentation.

RESULTS

Preferred Units 1

- 1 In the **Results** toolbar, click  **Configurations** and choose **Preferred Units**.
- 2 In the **Settings** window for **Preferred Units**, locate the **Units** section.

- 3 Click  **Add Physical Quantity**.
- 4 In the **Physical Quantity** dialog, select **Solid Mechanics > Stress tensor (N/m²)** in the tree.
- 5 Click **OK**.
- 6 In the **Settings** window for **Preferred Units**, locate the **Units** section.
- 7 In the table, enter the following settings:

Quantity	Unit	Preferred unit
Stress tensor	N/m ²	MPa

- 8 Click  **Apply**.

Stress, Unit Cell

- 1 In the **Model Builder** window, under **Results** click **Stress (solid)**.
- 2 In the **Settings** window for **3D Plot Group**, type **Stress, Unit Cell** in the **Label** text field.
- 3 Click to expand the **Title** section. From the **Title type** list, choose **Manual**.
- 4 Click to expand the **Plot Array** section. From the **Array type** list, choose **Linear**.

Selection 1

- 1 In the **Model Builder** window, expand the **Stress, Unit Cell** node.
- 2 Right-click **Volume 1** and choose **Selection**.
- 3 Select Domain 1 only.

Deformation

In the **Model Builder** window, right-click **Deformation** and choose **Delete**.

Volume 2

- 1 In the **Model Builder** window, under **Results > Stress, Unit Cell** right-click **Volume 1** and choose **Duplicate**.
- 2 In the **Settings** window for **Volume**, click to expand the **Inherit Style** section.
- 3 From the **Plot** list, choose **Volume 1**.
- 4 Click to expand the **Plot Array** section. Clear the **Apply to dataset edges** checkbox.

Selection 1

- 1 In the **Model Builder** window, expand the **Volume 2** node, then click **Selection 1**.
- 2 In the **Settings** window for **Selection**, locate the **Selection** section.
- 3 Click  **Clear Selection**.
- 4 Select Domain 2 only.

Surface 1

In the **Model Builder** window, expand the **Results > Stress, Thin Layer (solid)** node, then click **Surface 1**.

- 1 Drag and drop below **Stress, Unit Cell > Volume 2**.
- 2 In the **Settings** window for **Surface**, click to expand the **Inherit Style** section.
- 3 From the **Plot** list, choose **Volume 1**.
- 4 Click to expand the **Plot Array** section. Clear the **Apply to dataset edges** checkbox.

Deformation

- 1 In the **Model Builder** window, expand the **Surface 1** node.
- 2 Right-click **Deformation** and choose **Delete**.

Stress, Unit Cell

In the **Model Builder** window, under **Results** click **Stress, Unit Cell**.

Table Annotation 1

- 1 In the **Stress, Unit Cell** toolbar, click  **More Plots** and choose **Table Annotation**.
- 2 In the **Settings** window for **Table Annotation**, locate the **Data** section.
- 3 From the **Source** list, choose **Local table**.
- 4 In the table, enter the following settings:

x-coordinate	y-coordinate	z-coordinate	Annotation
-1/4	-1.2*1	0	Matrix
1	-1.2*1	0	Fiber
2.2*1	-1.2*1	0	Interface

- 5 Locate the **Coloring and Style** section. Clear the **Show point** checkbox.

Stress, Unit Cell

- 1 Click the  **Go to Default View** button in the **Graphics** toolbar.
- 2 Click the  **Show Grid** button in the **Graphics** toolbar.
- 3 In the **Model Builder** window, click **Stress, Unit Cell**.
- 4 In the **Stress, Unit Cell** toolbar, click  **Plot**.

Stress, Thin Layer (solid)

In the **Model Builder** window, right-click **Stress, Thin Layer (solid)** and choose **Delete**.

Stress, Unit Cell

In the **Model Builder** window, under **Results** right-click **Stress, Unit Cell** and choose **Group**.

Micromechanics (Material Properties)

In the **Settings** window for **Group**, type **Micromechanics (Material Properties)** in the **Label** text field.

Before you add a **Layered Shell** interface, create a homogenized material from the **Cell Periodicity** feature.

The homogenized material can be created by using either of the two action buttons in the **Periodicity type** section: **Create Material by Reference** or **Create Material by Value**. Choose the second action button in order to generate the material with numbers.

SOLID MECHANICS (SOLID)

Cell Periodicity 1

- 1 In the **Model Builder** window, under **Component: Micromechanics (Material Properties) (comp1) > Solid Mechanics (solid)** click **Cell Periodicity 1**.
- 2 In the **Settings** window for **Cell Periodicity**, click **Automated Model Setup** in the upper-right corner of the **Periodicity Settings** section. From the menu, choose **Create Material by Value** to generate a global material node with computed elastic properties.

Modeling Instructions (Macromechanics: Global Response)

This section describes how to carry out macromechanics analysis of a laminated composite cylinder using the **Layered Shell** interface based on the layerwise theory.

ADD COMPONENT

In the **Model Builder** window, right-click the root node and choose **Add Component > 3D**.



COMPONENT: MACROMECHANICS (GLOBAL RESPONSE)

In the **Settings** window for **Component**, type **Component: Macromechanics (Global Response)** in the **Label** text field.

GEOMETRY 2

Cylinder 1 (cyl1)

- 1 In the **Geometry** toolbar, click  **Cylinder**.
- 2 In the **Settings** window for **Cylinder**, locate the **Object Type** section.
- 3 From the **Type** list, choose **Surface**.



- 4 Locate the **Size and Shape** section. In the **Radius** text field, type rc .
- 5 In the **Height** text field, type hc .
- 6 Locate the **Axis** section. From the **Axis type** list, choose **x-axis**.
- 7 Click  **Build Selected**.
- 8 Click the  **Show Grid** button in the **Graphics** toolbar.

DEFINITIONS (COMP2)

Boundary System 2 (sys2)

- 1 In the **Model Builder** window, expand the **Component: Macromechanics (Global Response) (comp2) > Definitions** node, then click **Boundary System 2 (sys2)**.
- 2 In the **Settings** window for **Boundary System**, locate the **Settings** section.
- 3 Find the **Coordinate names** subsection. From the **Axis** list, choose **x**.

ADD PHYSICS

- 1 In the **Home** toolbar, click  **Add Physics** to open the **Add Physics** window.
- 2 Go to the **Add Physics** window.
- 3 In the tree, select **Structural Mechanics > Layered Shell (lshell)**.
- 4 Find the **Physics interfaces in study** subsection. In the table, clear the **Solve** checkbox for **Study: Micromechanics (Material Properties)**.
- 5 Click the **Add to Component: Macromechanics (Global Response)** button in the window toolbar.
- 6 In the **Home** toolbar, click  **Add Physics** to close the **Add Physics** window.

GLOBAL DEFINITIONS

The full laminate is a repetition of two layers. Therefore, it is sufficient to define only a part of it in the **Layered Material** node. The transformation into the full laminate is performed through layered material settings in the **Layered Material Link** node.

Layered Material: [90/0]_2

- 1 In the **Model Builder** window, under **Global Definitions** right-click **Materials** and choose **Layered Material**.
- 2 In the **Settings** window for **Layered Material**, type **Layered Material: [90/0]_2** in the **Label** text field.

3 Locate the **Layer Definition** section. In the table, enter the following settings:

Layer	Material	Rotation	Value	Thickness	Mesh elements
Layer 1	Homogeneous Material (solidcp1mat)	90	1.5708 rad	th	2

4 Click **Add**.

5 In the table, enter the following settings:

Layer	Material	Rotation	Value	Thickness	Mesh elements
Layer 2	Homogeneous Material (solidcp1mat)	0	0 rad	th	2

MATERIALS

Layered Material Link 1 (lmat1)

1 In the **Model Builder** window, under **Component: Macromechanics (Global Response) (comp2)** right-click **Materials** and choose **Layers > Layered Material Link**.

The laminate partially defined in the **Layered Material** node can be transformed into a full laminate using a transform option in the layered material settings.

- 2 In the **Settings** window for **Layered Material Link**, locate the **Layered Material Settings** section.
- 3 From the **Transform** list, choose **Repeated**.
- 4 In the **Number of repeats** text field, type 2.
- 5 Click to expand the **Preview Plot Settings** section. In the **Thickness-to-width ratio** text field, type 0.4.
- 6 Locate the **Layered Material Settings** section. Click **Layer Cross-Section Preview** in the upper-right corner of the section to enable the through-thickness view of the laminated material.
- 7 Click **Layer Stack Preview** in the upper-right corner of the **Layered Material Settings** section to show the stacking sequence including the fiber orientation.

LAYERED SHELL (LSHELL)

Linear Elastic Material 1

- 1 In the **Model Builder** window, under **Component: Macromechanics (Global Response) (comp2) > Layered Shell (lshell)** click **Linear Elastic Material 1**.
- 2 In the **Settings** window for **Linear Elastic Material**, locate the **Linear Elastic Material** section.
- 3 From the **Material symmetry** list, choose **Anisotropic**.

Add **Safety** features with composite-specific **Hashin** and **Puck** failure criteria.

Safety 1

- 1 In the **Physics** toolbar, click  **Attributes** and choose **Safety**.
- 2 In the **Settings** window for **Safety**, locate the **Failure Model** section.
- 3 From the **Failure criterion** list, choose **Hashin**.

Safety 2

- 1 Right-click **Safety 1** and choose **Duplicate**.
- 2 In the **Settings** window for **Safety**, locate the **Failure Model** section.
- 3 From the **Failure criterion** list, choose **Puck**.
- 4 Find the **Interfiber failure** subsection. In the p_{t1} text field, type 0.35.
- 5 In the p_{c1} text field, type 0.3.

GLOBAL DEFINITIONS

Homogeneous Material (solidcp1mat)

- 1 In the **Model Builder** window, under **Global Definitions > Materials** click **Homogeneous Material (solidcp1mat)**.
- 2 In the **Settings** window for **Material**, locate the **Material Contents** section.
- 3 In the table, enter the following settings:

Property	Variable	Value	Unit	Property group
Tensile strengths	{sigmats1, sigmats2, sigmats3}	{Sigmats1, Sigmats2, Sigmats3}	Pa	Orthotropic strength parameters, Voigt notation
Compressive strengths	{sigmacs1, sigmacs2, sigmacs3}	{Sigmacs1, Sigmacs2, Sigmacs3}	Pa	Orthotropic strength parameters, Voigt notation

Property	Variable	Value	Unit	Property group
Shear strengths	{sigmass1, sigmass2, sigmass3}	{Sigmass23, Sigmass13, Sigmass12}	Pa	Orthotropic strength parameters, Voigt notation
Ultimate tensile strain in longitudinal direction	epsilont1	epsilonts1	l	Orthotropic strength parameters, Voigt notation
Ultimate compressive strain in longitudinal direction	epsilonc1	epsiloncs1	l	Orthotropic strength parameters, Voigt notation
Young's modulus of fiber in longitudinal direction	Ef1	235[GPa]	Pa	Orthotropic strength parameters, Voigt notation
In-plane Poisson's ratio of fiber	nuf12	0.2	l	Orthotropic strength parameters, Voigt notation
Linear degradation stress	sigma1D	Sigma1D	N/m ²	Orthotropic strength parameters, Voigt notation

LAYERED SHELL (LSHELL)

Fixed Constraint 1

- 1 In the **Physics** toolbar, click  **Edges** and choose **Fixed Constraint**.
- 2 Select Edges 9–12 only.

Boundary Load 1

- 1 In the **Physics** toolbar, click  **Edges** and choose **Boundary Load**.
- 2 Select Edges 1, 2, 4, and 6 only.
- 3 In the **Settings** window for **Boundary Load**, locate the **Force** section.
- 4 From the **Load type** list, choose **Total force**.
- 5 Specify the \mathbf{F}_{tot} vector as

0	x
0	y
-7.5E4	z

MESH 2



Mapped 1

- 1 In the **Mesh** toolbar, click  **More Generators** and choose **Mapped**.
- 2 In the **Settings** window for **Mapped**, locate the **Boundary Selection** section.
- 3 From the **Selection** list, choose **All boundaries**.

Distribution 1

- 1 Right-click **Mapped 1** and choose **Distribution**.
- 2 In the **Settings** window for **Distribution**, locate the **Edge Selection** section.
- 3 From the **Selection** list, choose **All edges**.
- 4 Locate the **Distribution** section. In the **Number of elements** text field, type 20.
- 5 Click  **Build All**.

ADD STUDY

- 1 In the **Home** toolbar, click  **Add Study** to open the **Add Study** window.
- 2 Go to the **Add Study** window.
- 3 Find the **Studies** subsection. In the **Select Study** tree, select **General Studies > Stationary**.
- 4 Find the **Physics interfaces in study** subsection. In the table, clear the **Solve** checkbox for **Solid Mechanics (solid)**.
- 5 Click the **Add Study** button in the window toolbar.
- 6 In the **Home** toolbar, click  **Add Study** to close the **Add Study** window.

STUDY: MACROMECHANICS (GLOBAL RESPONSE)

- 1 In the **Settings** window for **Study**, type Study: Macromechanics (Global Response) in the **Label** text field.
- 2 In the **Study** toolbar, click  **Compute**.

RESULTS

Layered Material

- 1 In the **Model Builder** window, expand the **Results > Datasets** node, then click **Layered Material**.
- 2 In the **Settings** window for **Layered Material**, locate the **Layers** section.
- 3 In the **Scale** text field, type 5.



Stress (Ishell)

- 1 In the **Model Builder** window, under **Results** click **Stress (Ishell)**.
- 2 In the **Settings** window for **3D Plot Group**, locate the **Title** section.
- 3 From the **Title type** list, choose **Manual**.
- 4 Locate the **Color Legend** section. Select the **Show maximum and minimum values** checkbox.

Surface 1

- 1 In the **Model Builder** window, expand the **Stress (Ishell)** node, then click **Surface 1**.
- 2 In the **Stress (Ishell)** toolbar, click  **Plot**.

RESULT TEMPLATES

- 1 In the **Results** toolbar, click  **Result Templates** to open the **Result Templates** window.
- 2 Go to the **Result Templates** window.
- 3 In the tree, select **Study: Macromechanics (Global Response)/Solution 1 (3) (sol1) > Layered Shell > Stress, Slice (Ishell)**.
- 4 Click the **Add Result Template** button in the window toolbar.
- 5 In the **Results** toolbar, click  **Result Templates** to close the **Result Templates** window.

RESULTS

Stress, Slice (Ishell)

- 1 In the **Model Builder** window, expand the **Results > Stress, Slice (Ishell)** node, then click **Stress, Slice (Ishell)**.
- 2 In the **Settings** window for **3D Plot Group**, locate the **Plot Settings** section.
- 3 Clear the **Plot dataset edges** checkbox.

Layered Material Slice 1

- 1 In the **Model Builder** window, click **Layered Material Slice 1**.
- 2 In the **Settings** window for **Layered Material Slice**, click to expand the **Title** section.
- 3 From the **Title type** list, choose **Manual**.
- 4 Locate the **Through-Thickness Location** section. From the **Location definition** list, choose **Interfaces**.
- 5 Locate the **Layout** section. From the **Displacement** list, choose **Rectangular**.
- 6 From the **Orientation** list, choose **zx**.
- 7 In the **Relative x-separation** text field, type 0.3.

- 8 In the **Relative z-separation** text field, type 0.7.
- 9 Select the **Show descriptions** checkbox.
- 10 In the **Relative separation** text field, type 0.6.
- 11 Click to expand the **Quality** section. From the **Resolution** list, choose **No refinement**.

Deformation

- 1 In the **Model Builder** window, expand the **Layered Material Slice I** node.
- 2 Right-click **Deformation** and choose **Disable**.

Stress, Slice (Ishell)

- 1 In the **Model Builder** window, under **Results** click **Stress, Slice (Ishell)**.
- 2 In the **Stress, Slice (Ishell)** toolbar, click  **Plot**.

From the **Stress, Slice** it is clear that the maximum stress in fiber direction occurs either at the inner or outer layer of the composite cylinder. To get the position where the maximum stress in fiber direction occurs in the laminate, add a **Surface Maximum** derived-values node. These coordinates are useful for the next micromechanical analysis.

Surface Maximum I

- 1 In the **Model Builder** window, under **Results** right-click **Derived Values** and choose **Maximum > Surface Maximum**.
- 2 In the **Settings** window for **Surface Maximum**, locate the **Data** section.
- 3 From the **Dataset** list, choose **Study: Macromechanics (Global Response)/ Solution I (3) (sol1)**.
- 4 Locate the **Selection** section. From the **Selection** list, choose **All boundaries**.
- 5 Locate the **Expressions** section. In the table, enter the following settings:

Expression	Unit	Description
lshell.atxd1(0, lshell.s11Gp11)	N/m ²	Stress in the inner layer
lshell.atxd1(lshell.d, lshell.s11Gp11)	N/m ²	Stress in the outer layer

- 6 Click to expand the **Configuration** section. Select the **Include position** checkbox.
- 7 Click  **Evaluate**.

Use the following instructions to plot the through-thickness variation of the stress in fiber direction at a point where the stress is maximal.



Cut Point 3D 1

- 1 In the **Results** toolbar, click  **Cut Point 3D**.
- 2 In the **Settings** window for **Cut Point 3D**, locate the **Data** section.
- 3 From the **Dataset** list, choose **Study: Macromechanics (Global Response)/Solution 1 (3) (sol1)**.
- 4 Locate the **Point Data** section. In the **X** text field, type 0.
- 5 In the **Y** text field, type 0.
- 6 In the **Z** text field, type -rc.
- 7 From the **Snapping** list, choose **Snap to closest boundary**.

Cut Point 3D 2

- 1 Right-click **Cut Point 3D 1** and choose **Duplicate**.
- 2 In the **Settings** window for **Cut Point 3D**, locate the **Point Data** section.
- 3 In the **X** text field, type hc.
- 4 In the **Y** text field, type 0.
- 5 In the **Z** text field, type rc.

RESULT TEMPLATES

- 1 In the **Results** toolbar, click  **Result Templates** to open the **Result Templates** window.
- 2 Go to the **Result Templates** window.
- 3 In the tree, select **Study: Macromechanics (Global Response)/Solution 1 (3) (sol1) > Layered Shell > Stress, Through Thickness (Ishell)**.
- 4 Click the **Add Result Template** button in the window toolbar.
- 5 In the **Results** toolbar, click  **Result Templates** to close the **Result Templates** window.

RESULTS

Stress, Through Thickness (Ishell)

- 1 In the **Settings** window for **ID Plot Group**, locate the **Plot Settings** section.
- 2 In the **x-axis label** text field, type Stress tensor, layer coordinate system (MPa).

Through Thickness 1

- 1 In the **Model Builder** window, expand the **Stress, Through Thickness (Ishell)** node, then click **Through Thickness 1**.
- 2 In the **Settings** window for **Through Thickness**, locate the **Data** section.

- 3 From the **Dataset** list, choose **Cut Point 3D 1**.
- 4 Locate the **x-Axis Data** section. In the **Expression** text field, type `1shell.s11Gp11`.
- 5 Click to expand the **Legends** section. From the **Legends** list, choose **Manual**.
- 6 In the table, enter the following settings:

Legends
Cut Point 1

Through Thickness 2

- 1 In the **Model Builder** window, click **Through Thickness 2**.
- 2 In the **Settings** window for **Through Thickness**, locate the **Data** section.
- 3 From the **Dataset** list, choose **Cut Point 3D 2**.
- 4 Locate the **x-Axis Data** section. In the **Expression** text field, type `1shell.s11Gp11`.
- 5 Click to expand the **Legends** section. From the **Legends** list, choose **Manual**.
- 6 In the table, enter the following settings:

Legends
Cut Point 2

- 7 In the **Stress, Through Thickness (Ishell)** toolbar, click  **Plot**.

RESULT TEMPLATES

- 1 In the **Results** toolbar, click  **Result Templates** to open the **Result Templates** window.
- 2 Go to the **Result Templates** window.
- 3 In the tree, select **Study: Macromechanics (Global Response)/Solution 1 (3) (sol1) > Layered Shell > Failure Indices (Ishell) > Failure Index (Safety 1)**.
- 4 Click the **Add Result Template** button in the window toolbar.

RESULTS

Hashin Failure Index

- 1 In the **Settings** window for **3D Plot Group**, type `Hashin Failure Index` in the **Label** text field.
- 2 Locate the **Title** section. From the **Title type** list, choose **Manual**.
- 3 In the **Title** text area, type `Hashin Failure Index`.
- 4 Locate the **Color Legend** section. Select the **Show maximum and minimum values** checkbox.

5 Locate the **Data** section. Click  **Go to Source**.

Layered Material 2 (Safety)

1 In the **Model Builder** window, under **Results > Datasets** click **Layered Material 2 (Safety)**.

2 In the **Settings** window for **Layered Material**, locate the **Layers** section.

3 In the **Scale** text field, type 12.

Marker 1

1 In the **Model Builder** window, expand the **Results > Hashin Failure Index** node.

2 Right-click **Surface 1** and choose **Marker**.

3 In the **Settings** window for **Marker**, locate the **Display** section.

4 From the **Display** list, choose **Max**.

5 Locate the **Text Format** section. In the **Precision** text field, type 3.

6 Locate the **Coloring and Style** section. In the **Point radius** text field, type 4.

7 From the **Background color** list, choose **Gray**.

8 From the **Anchor point** list, choose **Lower right**.

9 In the **Hashin Failure Index** toolbar, click  **Plot**.

RESULT TEMPLATES

1 Go to the **Result Templates** window.

2 In the tree, select **Study: Macromechanics (Global Response)/Solution 1 (3) (sol1) > Layered Shell > Failure Indices (Ishell) > Failure Index (Safety 2)**.

3 Click the **Add Result Template** button in the window toolbar.

4 In the **Results** toolbar, click  **Result Templates** to close the **Result Templates** window.

RESULTS

Puck Failure Index

1 In the **Settings** window for **3D Plot Group**, type Puck Failure Index in the **Label** text field.

2 Locate the **Title** section. From the **Title type** list, choose **Manual**.

3 In the **Title** text area, type Puck Failure Index.

4 Locate the **Color Legend** section. Select the **Show maximum and minimum values** checkbox.

Marker 1

1 In the **Model Builder** window, expand the **Puck Failure Index** node.

- 2 Right-click **Surface 1** and choose **Marker**.
- 3 In the **Settings** window for **Marker**, locate the **Display** section.
- 4 From the **Display** list, choose **Max**.
- 5 Locate the **Text Format** section. In the **Precision** text field, type 3.
- 6 Locate the **Coloring and Style** section. In the **Point radius** text field, type 4.
- 7 From the **Background color** list, choose **Gray**.
- 8 From the **Anchor point** list, choose **Lower right**.
- 9 In the **Puck Failure Index** toolbar, click  **Plot**.

Hashin Failure Indexes (Study: Macromechanics (Global Response))

- 1 In the **Results** toolbar, click  **Evaluation Group**.
- 2 In the **Settings** window for **Evaluation Group**, type Hashin Failure Indexes (Study: Macromechanics (Global Response)) in the **Label** text field.
- 3 Locate the **Data** section. From the **Dataset** list, choose **Layered Material 2 (Safety)**.

Volume Maximum 1

- 1 Right-click **Hashin Failure Indexes (Study: Macromechanics (Global Response))** and choose **Maximum > Volume Maximum**.
- 2 In the **Settings** window for **Volume Maximum**, click **Add Expression** in the upper-right corner of the **Expressions** section. From the menu, choose **Component: Macromechanics (Global Response) (comp2) > Layered Shell > Safety > Hashin > Ishell.lemml.sfl.f_ifT - Hashin fiber tensile failure index - 1**.
- 3 Click **Add Expression** in the upper-right corner of the **Expressions** section. From the menu, choose **Component: Macromechanics (Global Response) (comp2) > Layered Shell > Safety > Hashin > Ishell.lemml.sfl.f_ifC - Hashin fiber compressive failure index - 1**.
- 4 Click **Add Expression** in the upper-right corner of the **Expressions** section. From the menu, choose **Component: Macromechanics (Global Response) (comp2) > Layered Shell > Safety > Hashin > Ishell.lemml.sfl.f_imT - Hashin matrix tensile failure index - 1**.
- 5 Click **Add Expression** in the upper-right corner of the **Expressions** section. From the menu, choose **Component: Macromechanics (Global Response) (comp2) > Layered Shell > Safety > Hashin > Ishell.lemml.sfl.f_imC - Hashin matrix compressive failure index - 1**.
- 6 Click **Add Expression** in the upper-right corner of the **Expressions** section. From the menu, choose **Component: Macromechanics (Global Response) (comp2) > Layered Shell > Safety > Hashin > Ishell.lemml.sfl.f_iiT - Hashin interlaminar tensile failure index - 1**.

- Click **Add Expression** in the upper-right corner of the **Expressions** section. From the menu, choose **Component: Macromechanics (Global Response) (comp2) > Layered Shell > Safety > Hashin > lshell.lemm1.sf1.f_iiC - Hashin interlaminar compressive failure index - I**.

Hashin Failure Indexes (Study: Macromechanics (Global Response))

- In the **Model Builder** window, click **Hashin Failure Indexes (Study: Macromechanics (Global Response))**.
- In the **Settings** window for **Evaluation Group**, locate the **Transformation** section.
- Select the **Transpose** checkbox.
- In the **Hashin Failure Indexes (Study: Macromechanics (Global Response))** toolbar, click  **Evaluate**.

Puck Failure Indexes (Study: Macromechanics (Global Response))

- In the **Results** toolbar, click  **Evaluation Group**.
- In the **Settings** window for **Evaluation Group**, type Puck Failure Indexes (Study: Macromechanics (Global Response)) in the **Label** text field.
- Locate the **Data** section. From the **Dataset** list, choose **Layered Material 2 (Safety)**.

Volume Maximum I

- Right-click **Puck Failure Indexes (Study: Macromechanics (Global Response))** and choose **Maximum > Volume Maximum**.
- In the **Settings** window for **Volume Maximum**, click **Add Expression** in the upper-right corner of the **Expressions** section. From the menu, choose **Component: Macromechanics (Global Response) (comp2) > Layered Shell > Safety > Puck > lshell.lemm1.sf2.f_ifT - Puck fiber tensile failure index - I**.
- Click **Add Expression** in the upper-right corner of the **Expressions** section. From the menu, choose **Component: Macromechanics (Global Response) (comp2) > Layered Shell > Safety > Puck > lshell.lemm1.sf2.f_ifC - Puck fiber compressive failure index - I**.
- Click **Add Expression** in the upper-right corner of the **Expressions** section. From the menu, choose **Component: Macromechanics (Global Response) (comp2) > Layered Shell > Safety > Puck > lshell.lemm1.sf2.f_imA - Puck interfiber mode A failure index - I**.
- Click **Add Expression** in the upper-right corner of the **Expressions** section. From the menu, choose **Component: Macromechanics (Global Response) (comp2) > Layered Shell > Safety > Puck > lshell.lemm1.sf2.f_imB - Puck interfiber mode B failure index - I**.
- Click **Add Expression** in the upper-right corner of the **Expressions** section. From the menu, choose **Component: Macromechanics (Global Response) (comp2) > Layered Shell > Safety > Puck > lshell.lemm1.sf2.f_imC - Puck interfiber mode C failure index - I**.

Puck Failure Indexes (Study: Macromechanics (Global Response))

- 1 In the **Model Builder** window, click **Puck Failure Indexes (Study: Macromechanics (Global Response))**.
- 2 In the **Settings** window for **Evaluation Group**, locate the **Transformation** section.
- 3 Select the **Transpose** checkbox.
- 4 In the **Puck Failure Indexes (Study: Macromechanics (Global Response))** toolbar, click  **Evaluate**.

Hashin Failure Index, Puck Failure Index, Stress (Ishell), Stress, Slice (Ishell), Stress, Through Thickness (Ishell)

- 1 In the **Model Builder** window, under **Results**, Ctrl-click to select **Stress (Ishell)**, **Stress, Slice (Ishell)**, **Stress, Through Thickness (Ishell)**, **Hashin Failure Index**, and **Puck Failure Index**.
- 2 Right-click and choose **Group**.

Macromechanics (Global Response)

In the **Settings** window for **Group**, type Macromechanics (Global Response) in the **Label** text field.

Modeling Instructions (Micromechanics: Local Response)

This section describes how to carry out micromechanical failure analysis of a unit cell using the macro level strain field from the global analysis of the **Layered Shell** interface.

In order to do a micromechanical analysis at multiple material points, create a list of such point coordinates using a **Parameter** node. The points where the maximum stress occurs in inner and outer layers are included in this list.

GLOBAL DEFINITIONS

Material Point Location

- 1 In the **Home** toolbar, click  **Parameters** and choose **Add > Parameters**.
- 2 In the **Settings** window for **Parameters**, type Material Point Location in the **Label** text field.
- 3 Locate the **Parameters** section. In the table, enter the following settings:

Name	Expression	Value	Description
X0	0[m]	0 m	Material point, X coordinate

Name	Expression	Value	Description
Y0	0[m]	0 m	Material point, Y coordinate
Z0	-rc	-0.1 m	Material point, Z coordinate

4 In the **Home** toolbar, click  **Parameter Case**.

5 Right-click **Global Definitions** > **Material Point Location** > **Case 1** and choose **Duplicate**.

6 In the **Settings** window for **Case**, locate the **Parameters** section.

7 In the table, enter the following settings:

Name	Expression	Description
X0	hc/2	Material point, X coordinate
Y0	0[m]	Material point, Y coordinate
Z0	-rc	Material point, Z coordinate

8 Right-click **Global Definitions** > **Material Point Location** > **Case 2** and choose **Duplicate**.

9 In the **Settings** window for **Case**, locate the **Parameters** section.

10 In the table, enter the following settings:

Name	Expression	Description
X0	hc	Material point, X coordinate
Y0	0[m]	Material point, Y coordinate
Z0	-rc	Material point, Z coordinate

11 Right-click **Global Definitions** > **Material Point Location** > **Case 3** and choose **Duplicate**.

12 In the **Settings** window for **Case**, locate the **Parameters** section.

13 In the table, enter the following settings:

Name	Expression	Description
X0	0[m]	Material point, X coordinate
Y0	0[m]	Material point, Y coordinate
Z0	rc	Material point, Z coordinate

14 Right-click **Global Definitions** > **Material Point Location** > **Case 4** and choose **Duplicate**.

15 In the **Settings** window for **Case**, locate the **Parameters** section.

16 In the table, enter the following settings:

Name	Expression	Description
X0	hc/2	Material point, X coordinate
Y0	0[m]	Material point, Y coordinate
Z0	rc	Material point, Z coordinate

17 Right-click **Global Definitions > Material Point Location > Case 5** and choose **Duplicate**.

18 In the **Settings** window for **Case**, locate the **Parameters** section.

19 In the table, enter the following settings:

Name	Expression	Description
X0	hc	Material point, X coordinate
Y0	0[m]	Material point, Y coordinate
Z0	rc	Material point, Z coordinate

COMPONENT: MICROMECHANICS (MATERIAL PROPERTIES) (COMP1)

The model setup can be simplified by copying the **Component: Micromechanics (Material Properties)** component.

In the **Model Builder** window, right-click

Component: Micromechanics (Material Properties) (comp1) and choose **Copy**.

COMPONENT: MICROMECHANICS (MATERIAL PROPERTIES) I (COMP3)

In the **Model Builder** window, right-click the root node and choose **Paste Multiple Items**.

COMPONENT: MICROMECHANICS (LOCAL RESPONSE)

1 In the **Messages from Paste** dialog, click **OK**.

2 In the **Model Builder** window, click



Component: Micromechanics (Material Properties) I (comp3).

3 In the **Settings** window for **Component**, type **Component: Micromechanics (Local Response)** in the **Label** text field.

The unit cell is analyzed at different through-thickness locations of the composite cylinder where the layers have different rotation angles with respect to the laminate coordinate system. Hence, rotate the unit cell geometry with a conditional rotation angle expression.

GEOMETRY I

Rotate 1 (rot1)

- 1 In the **Geometry** toolbar, click  **Transforms** and choose **Rotate**.
- 2 Select the object **pill** only.
- 3 In the **Settings** window for **Rotate**, locate the **Rotation** section.
- 4 In the **Angle** text field, type `if(xd==0,90[deg],0)`.
- 5 Click  **Build Selected**.

In order to input the fiber material properties in the correct coordinate system, use a **Rotated System**.

DEFINITIONS (COMP3)

Rotated System 4 (sys4)

- 1 In the **Definitions** toolbar, click  **Coordinate Systems** and choose **Rotated System**.
- 2 In the **Settings** window for **Rotated System**, locate the **Rotation** section.
- 3 Find the **Euler angles** subsection. In the α text field, type `if(xd==0,90[deg],0)`.

Boundary System 1 (sys3)

- 1 In the **Model Builder** window, click **Boundary System 1 (sys3)**.
- 2 In the **Settings** window for **Boundary System**, locate the **Settings** section.
- 3 Find the **Coordinate names** subsection. From the **Create first tangent direction from** list, choose **Rotated System 4 (sys4)**.
- 4 From the **Axis** list, choose **x1**.

The failure criteria used for fiber, matrix, and interface materials are user defined, so use a **Variable** node to define them.

Variables 1

- 1 In the **Model Builder** window, right-click **Definitions** and choose **Variables**.
- 2 In the **Settings** window for **Variables**, locate the **Variables** section.
- 3 Click  **Load from File**.
- 4 Browse to the model's Application Libraries folder and double-click the file `composite_multiscale_variables.txt`.

SOLID MECHANICS (SOLID2)

Linear Elastic Material 1

- 1 In the **Model Builder** window, expand the **Component: Micromechanics (Local Response) (comp3) > Solid Mechanics (solid2)** node, then click **Linear Elastic Material 1**.
- 2 In the **Settings** window for **Linear Elastic Material**, locate the **Coordinate System Selection** section.
- 3 From the **Coordinate system** list, choose **Rotated System 4 (sys4)**.

Add **Safety** features to the matrix, fiber, and interface domains. Use user-defined criteria.

Fiber Failure Criterion

- 1 In the **Physics** toolbar, click  **Attributes** and choose **Safety**.
- 2 In the **Settings** window for **Safety**, type Fiber Failure Criterion in the **Label** text field.
- 3 Select Domain 2 only.
- 4 Locate the **Failure Model** section. From the **Failure criterion** list, choose **User defined**.
- 5 In the $g(\sigma)$ text field, type `g_f`.
- 6 In the $s_f(\sigma)$ text field, type `sf_f`.

Linear Elastic Material 1

In the **Model Builder** window, click **Linear Elastic Material 1**.

Matrix Failure Criterion

- 1 In the **Physics** toolbar, click  **Attributes** and choose **Safety**.
- 2 In the **Settings** window for **Safety**, type Matrix Failure Criterion in the **Label** text field.
- 3 Select Domain 1 only.
- 4 Locate the **Failure Model** section. From the **Failure criterion** list, choose **User defined**.
- 5 In the $g(\sigma)$ text field, type `g_m`.
- 6 In the $s_f(\sigma)$ text field, type `sf_m`.

Thin Layer 1

In the **Model Builder** window, expand the **Component: Micromechanics (Local Response) (comp3) > Solid Mechanics (solid2) > Thin Layer 1** node.

Linear Elastic Material I

In the **Model Builder** window, expand the

Component: Micromechanics (Local Response) (comp3) > Solid Mechanics (solid2) > Thin Layer I > Linear Elastic Material I node, then click **Linear Elastic Material I**.

Interface Failure Criterion

- 1 In the **Physics** toolbar, click  **Attributes** and choose **Safety**.
- 2 In the **Settings** window for **Safety**, type Interface Failure Criterion in the **Label** text field.
- 3 Locate the **Failure Model** section. From the **Failure criterion** list, choose **User defined**.
- 4 In the $g(\sigma)$ text field, type g_i .
- 5 In the $s_f(\sigma)$ text field, type sf_i .

Cell Periodicity I

- 1 In the **Model Builder** window, under **Component: Micromechanics (Local Response) (comp3) > Solid Mechanics (solid2)** click **Cell Periodicity I**.
- 2 In the **Settings** window for **Cell Periodicity**, locate the **Periodicity Settings** section.
- 3 From the **Boundary conditions** list, choose **Mixed**.
- 4 Find the **XX component** subsection. In the ϵ_{avgXX} text field, type eXX .
- 5 Find the **YY component** subsection. In the ϵ_{avgYY} text field, type eYY .
- 6 Find the **ZZ component** subsection. In the ϵ_{avgZZ} text field, type eZZ .
- 7 Find the **XY component** subsection. In the ϵ_{avgXY} text field, type eXY .
- 8 Find the **YZ component** subsection. In the ϵ_{avgYZ} text field, type eYZ .
- 9 Find the **XZ component** subsection. In the ϵ_{avgXZ} text field, type eXZ .

MESH I

Swept I

- 1 In the **Model Builder** window, expand the **Component: Micromechanics (Local Response) (comp3) > Mesh I** node.
- 2 Right-click **Component: Micromechanics (Local Response) (comp3) > Mesh I > Swept I** and choose **Build Selected**.

ADD STUDY

- 1 In the **Home** toolbar, click  **Add Study** to open the **Add Study** window.
- 2 Go to the **Add Study** window.

- 3 Find the **Studies** subsection. In the **Select Study** tree, select **General Studies > Stationary**.
- 4 Find the **Physics interfaces in study** subsection. In the table, clear the **Solve** checkboxes for **Solid Mechanics (solid)** and **Layered Shell (Ishell)**.
- 5 Click the **Add Study** button in the window toolbar.
- 6 In the **Home** toolbar, click  **Add Study** to close the **Add Study** window.

STUDY: MICROMECHANICS (LOCAL RESPONSE)

- 1 In the **Settings** window for **Study**, type **Study: Micromechanics (Local Response)** in the **Label** text field.
- 2 Locate the **Study Settings** section. Clear the **Generate default plots** checkbox.

Parametric Sweep

- 1 In the **Study** toolbar, click  **Parametric Sweep**.
Add two **Parametric Sweep** nodes, one for different in-plane locations and another for different through-thickness locations.
- 2 In the **Settings** window for **Parametric Sweep**, locate the **Study Settings** section.
- 3 From the **Sweep type** list, choose **Parameter switch**.
- 4 Click **+ Add**.
- 5 In the table, enter the following settings:

Switch	Cases	Case numbers
Material Point Location	All	range(1,1,6)

Parametric Sweep 2

- 1 In the **Study** toolbar, click  **Parametric Sweep**.
- 2 In the **Settings** window for **Parametric Sweep**, locate the **Study Settings** section.
- 3 Click **+ Add**.
- 4 In the table, enter the following settings:

Parameter name	Parameter value list	Parameter unit
xd (Extra dimension location)	0 4*th	mm

Step 1: Stationary

- 1 In the **Model Builder** window, click **Step 1: Stationary**.
- 2 In the **Settings** window for **Stationary**, click to expand the **Values of Dependent Variables** section.

- 3 Find the **Values of variables not solved for** subsection. From the **Settings** list, choose **User controlled**.
- 4 From the **Method** list, choose **Solution**.
- 5 From the **Study** list, choose **Study: Macromechanics (Global Response), Stationary**.
- 6 In the **Study** toolbar, click  **Compute**.

RESULTS

Micromechanics (Local Response)

- 1 In the **Model Builder** window, right-click **Micromechanics (Material Properties)** and choose **Duplicate**.
- 2 In the **Settings** window for **Group**, type **Micromechanics (Local Response)** in the **Label** text field.

Stress, Unit Cell (At First Material Point in Inner Layer)

- 1 In the **Model Builder** window, expand the **Micromechanics (Local Response)** node, then click **Stress, Unit Cell I**.
- 2 In the **Settings** window for **3D Plot Group**, type **Stress, Unit Cell (At First Material Point in Inner Layer)** in the **Label** text field.
- 3 Locate the **Data** section. From the **Dataset** list, choose **Study: Micromechanics (Local Response)/Parametric Solutions I (9) (sol3)**.
- 4 From the **Parameter value (xd (mm))** list, choose **0**.
- 5 From the **Material Point Location** list, choose **Case I**.
- 6 Locate the **Title** section. Clear the **Parameter indicator** text field.

Volume I

- 1 In the **Model Builder** window, expand the **Stress, Unit Cell (At First Material Point in Inner Layer)** node, then click **Volume I**.
- 2 In the **Settings** window for **Volume**, locate the **Expression** section.
- 3 In the **Expression** text field, type `solid2.mises`.

Selection I

- 1 In the **Model Builder** window, expand the **Volume I** node, then click **Selection I**.
- 2 In the **Settings** window for **Selection**, locate the **Selection** section.
- 3 Click to select the  **Activate Selection** toggle button.
- 4 Select Domain 1 only.

Volume 2

- 1 In the **Model Builder** window, under **Results > Micromechanics (Local Response) > Stress, Unit Cell (At First Material Point in Inner Layer)** click **Volume 2**.
- 2 In the **Settings** window for **Volume**, locate the **Expression** section.
- 3 In the **Expression** text field, type `solid2.mises`.



Selection 1

- 1 In the **Model Builder** window, expand the **Volume 2** node, then click **Selection 1**.
- 2 In the **Settings** window for **Selection**, locate the **Selection** section.
- 3 Click to select the  **Activate Selection** toggle button.
- 4 Select Domain 2 only.

Surface 1

- 1 In the **Model Builder** window, under **Results > Micromechanics (Local Response) > Stress, Unit Cell (At First Material Point in Inner Layer)** click **Surface 1**.
- 2 In the **Settings** window for **Surface**, locate the **Expression** section.
- 3 In the **Expression** text field, type `solid2.mises`.

Selection 1

- 1 In the **Model Builder** window, click **Selection 1**.
- 2 In the **Settings** window for **Selection**, locate the **Selection** section.
- 3 Click to select the  **Activate Selection** toggle button.
- 4 Select Boundaries 6–9 only.
- 5 Click the  **Zoom Extents** button in the **Graphics** toolbar.
- 6 In the **Stress, Unit Cell (At First Material Point in Inner Layer)** toolbar, click  **Plot**.

Stress, Unit Cell (At Multiple Material Points)

- 1 In the **Results** toolbar, click  **3D Plot Group**.
- 2 In the **Settings** window for **3D Plot Group**, type **Stress, Unit Cell (At Multiple Material Points)** in the **Label** text field.
- 3 Locate the **Data** section. From the **Dataset** list, choose **Study: Micromechanics (Local Response)/Parametric Solutions 1 (9) (sol3)**.
- 4 Locate the **Title** section. From the **Title type** list, choose **Manual**.
- 5 In the **Title** text area, type `von Mises stress (MPa)`.
- 6 Clear the **Parameter indicator** text field.
- 7 Locate the **Plot Settings** section. Clear the **Plot dataset edges** checkbox.

Surface 1

- 1 Right-click **Stress, Unit Cell (At Multiple Material Points)** and choose **Surface**.
- 2 In the **Settings** window for **Surface**, locate the **Data** section.
- 3 From the **Dataset** list, choose **Study: Micromechanics (Local Response)/ Parametric Solutions 1 (9) (sol3)**.
- 4 From the **Parameter value (xd (mm))** list, choose **0**.
- 5 From the **Material Point Location** list, choose **Case 1**.
- 6 Locate the **Expression** section. In the **Expression** text field, type `solid2.mises`.
- 7 Click to expand the **Range** section. Select the **Manual color range** checkbox.
- 8 In the **Maximum** text field, type 100.
- 9 Locate the **Coloring and Style** section. From the **Color table** list, choose **Prism**.
- 10 Click to expand the **Quality** section. From the **Evaluation settings** list, choose **Manual**.
- 11 From the **Resolution** list, choose **Custom**.
- 12 In the **Element refinement** text field, type 2.
- 13 From the **Smoothing threshold** list, choose **Manual**.
- 14 In the **Threshold** text field, type 0.2.

Transformation 1

- 1 Right-click **Surface 1** and choose **Transformation**.
- 2 In the **Settings** window for **Transformation**, locate the **Transformation** section.
- 3 In the **X** text field, type `X0`.
- 4 In the **Y** text field, type `Y0`.
- 5 In the **Z** text field, type `Z0+18*th`.

Surface 2

- 1 In the **Model Builder** window, under **Results > Micromechanics (Local Response) > Stress, Unit Cell (At Multiple Material Points)** right-click **Surface 1** and choose **Duplicate**.
- 2 In the **Settings** window for **Surface**, locate the **Data** section.
- 3 From the **Material Point Location** list, choose **Case 2**.
- 4 Locate the **Inherit Style** section. From the **Plot** list, choose **Surface 1**.

Surface 3

- 1 Right-click **Surface 2** and choose **Duplicate**.
- 2 In the **Settings** window for **Surface**, locate the **Data** section.
- 3 From the **Material Point Location** list, choose **Case 3**.

Surface 4

- 1 Right-click **Surface 3** and choose **Duplicate**.
- 2 In the **Settings** window for **Surface**, locate the **Data** section.
- 3 From the **Material Point Location** list, choose **Case 4**.

Transformation 1

- 1 In the **Model Builder** window, expand the **Surface 4** node, then click **Transformation 1**.
- 2 In the **Settings** window for **Transformation**, locate the **Transformation** section.
- 3 In the **Z** text field, type $Z0-18*th$.

Surface 5

- 1 In the **Model Builder** window, under **Results > Micromechanics (Local Response) > Stress, Unit Cell (At Multiple Material Points)** right-click **Surface 4** and choose **Duplicate**.
- 2 In the **Settings** window for **Surface**, locate the **Data** section.
- 3 From the **Material Point Location** list, choose **Case 5**.

Surface 6

- 1 Right-click **Surface 5** and choose **Duplicate**.
- 2 In the **Settings** window for **Surface**, locate the **Data** section.
- 3 From the **Material Point Location** list, choose **Case 6**.

Surface 7

- 1 Right-click **Surface 6** and choose **Duplicate**.
- 2 In the **Settings** window for **Surface**, locate the **Data** section.
- 3 From the **Parameter value (xd (mm))** list, choose **4**.
- 4 From the **Material Point Location** list, choose **Case 1**.

Surface 8

- 1 Right-click **Surface 7** and choose **Duplicate**.
- 2 In the **Settings** window for **Surface**, locate the **Data** section.
- 3 From the **Material Point Location** list, choose **Case 2**.

Surface 9

- 1 Right-click **Surface 8** and choose **Duplicate**.
- 2 In the **Settings** window for **Surface**, locate the **Data** section.
- 3 From the **Material Point Location** list, choose **Case 3**.

Surface 10

- 1 Right-click **Surface 9** and choose **Duplicate**.
- 2 In the **Settings** window for **Surface**, locate the **Data** section.
- 3 From the **Material Point Location** list, choose **Case 4**.

Transformation 1

- 1 In the **Model Builder** window, expand the **Surface 10** node, then click **Transformation 1**.
- 2 In the **Settings** window for **Transformation**, locate the **Transformation** section.
- 3 In the **Z** text field, type $Z0+18*th$.

Surface 11

- 1 In the **Model Builder** window, under **Results > Micromechanics (Local Response) > Stress, Unit Cell (At Multiple Material Points)** right-click **Surface 10** and choose **Duplicate**.
- 2 In the **Settings** window for **Surface**, locate the **Data** section.
- 3 From the **Material Point Location** list, choose **Case 5**.



Surface 12

- 1 Right-click **Surface 11** and choose **Duplicate**.
- 2 In the **Settings** window for **Surface**, locate the **Data** section.
- 3 From the **Material Point Location** list, choose **Case 6**.

Line 1

- 1 In the **Model Builder** window, right-click **Stress, Unit Cell (At Multiple Material Points)** and choose **Line**.
- 2 In the **Settings** window for **Line**, locate the **Expression** section.
- 3 In the **Expression** text field, type 0.
- 4 Locate the **Data** section. From the **Dataset** list, choose **Layered Material 2 (Safety)**.
- 5 Locate the **Coloring and Style** section. From the **Coloring** list, choose **Uniform**.
- 6 From the **Color** list, choose **Black**.

Stress, Unit Cell (At Multiple Material Points)

- 1 Click the  **Zoom Extents** button in the **Graphics** toolbar.
- 2 In the **Model Builder** window, click **Stress, Unit Cell (At Multiple Material Points)**.
- 3 In the **Settings** window for **3D Plot Group**, locate the **Plot Settings** section.
- 4 From the **View** list, choose **New view**.
- 5 In the **Stress, Unit Cell (At Multiple Material Points)** toolbar, click  **Plot**.

User Defined Failure Indexes (At First Material Point in Inner Layer)

- 1 In the **Model Builder** window, right-click **Stress, Unit Cell (At First Material Point in Inner Layer)** and choose **Duplicate**.
- 2 In the **Settings** window for **3D Plot Group**, type **User Defined Failure Indexes (At First Material Point in Inner Layer)** in the **Label** text field.
- 3 Locate the **Title** section. In the **Title** text area, type **User Defined failure index (1)**.
- 4 Locate the **Color Legend** section. Select the **Show maximum and minimum values** checkbox.

Volume 1

- 1 In the **Model Builder** window, expand the **User Defined Failure Indexes (At First Material Point in Inner Layer)** node, then click **Volume 1**.
- 2 In the **Settings** window for **Volume**, click **Replace Expression** in the upper-right corner of the **Expression** section. From the menu, choose **Component: Micromechanics (Local Response) (comp3) > Solid Mechanics > Safety > User defined > solid2.lemm1.sf2.f_i - User-defined failure index - 1**.



Volume 2

- 1 In the **Model Builder** window, click **Volume 2**.
- 2 In the **Settings** window for **Volume**, click **Replace Expression** in the upper-right corner of the **Expression** section. From the menu, choose **Component: Micromechanics (Local Response) (comp3) > Solid Mechanics > Safety > User defined > solid2.lemm1.sf1.f_i - User-defined failure index - 1**.



Surface 1

- 1 In the **Model Builder** window, click **Surface 1**.
- 2 In the **Settings** window for **Surface**, click **Replace Expression** in the upper-right corner of the **Expression** section. From the menu, choose **Component: Micromechanics (Local Response) (comp3) > Solid Mechanics > Safety > User defined > solid2.tl1.lemm1.sf1.f_i - User-defined failure index - 1**.

User Defined Failure Indexes (At First Material Point in Inner Layer)

- 1 Click the  **Zoom Extents** button in the **Graphics** toolbar.
- 2 In the **Model Builder** window, click **User Defined Failure Indexes (At First Material Point in Inner Layer)**.
- 3 In the **User Defined Failure Indexes (At First Material Point in Inner Layer)** toolbar, click  **Plot**.

User Defined Failure Indexes (At First Material Point in Outer Layer)

- 1 Right-click **User Defined Failure Indexes (At First Material Point in Inner Layer)** and choose **Duplicate**.
- 2 In the **Settings** window for **3D Plot Group**, type User Defined Failure Indexes (At First Material Point in Outer Layer) in the **Label** text field.
- 3 Locate the **Data** section. From the **Parameter value (xd (mm))** list, choose **4**.
- 4 Click the  **Zoom Extents** button in the **Graphics** toolbar.
- 5 In the **User Defined Failure Indexes (At First Material Point in Outer Layer)** toolbar, click  **Plot**.

User Defined Failure Indexes at First Material Point in Inner Layer (Study: Micromechanics (Local Response))

- 1 In the **Results** toolbar, click  **Evaluation Group**.
- 2 In the **Settings** window for **Evaluation Group**, type User Defined Failure Indexes at First Material Point in Inner Layer (Study: Micromechanics (Local Response)) in the **Label** text field.
- 3 Locate the **Data** section. From the **Dataset** list, choose **Study: Micromechanics (Local Response)/Parametric Solutions 1 (9) (sol3)**.
- 4 From the **Parameter selection (xd)** list, choose **First**.
- 5 From the **Material Point Location** list, choose **First**.

Volume Maximum 1

- 1 Right-click **User Defined Failure Indexes at First Material Point in Inner Layer (Study: Micromechanics (Local Response))** and choose **Maximum > Volume Maximum**.
- 2 Select Domain 1 only.
- 3 In the **Settings** window for **Volume Maximum**, click **Replace Expression** in the upper-right corner of the **Expressions** section. From the menu, choose **Component: Micromechanics (Local Response) (comp3) > Solid Mechanics > Safety > User defined > solid2.lemm1.sf2.f_i - User-defined failure index - 1**.
- 4 Locate the **Expressions** section. In the table, enter the following settings:

Expression	Unit	Description
solid2.lemm1.sf2.f_i	1	User-defined matrix failure index

Volume Maximum 2

- 1 In the **Model Builder** window, right-click **User Defined Failure Indexes at First Material Point in Inner Layer (Study: Micromechanics (Local Response))** and choose **Maximum > Volume Maximum**.
- 2 Select Domain 2 only.
- 3 In the **Settings** window for **Volume Maximum**, click **Replace Expression** in the upper-right corner of the **Expressions** section. From the menu, choose **Component: Micromechanics (Local Response) (comp3) > Solid Mechanics > Safety > User defined > solid2.lemm1.sf1.f_i - User-defined failure index - 1**.
- 4 Locate the **Expressions** section. In the table, enter the following settings:

Expression	Unit	Description
solid2.lemm1.sf1.f_i	1	User-defined fiber failure index

Surface Maximum 3

- 1 Right-click **User Defined Failure Indexes at First Material Point in Inner Layer (Study: Micromechanics (Local Response))** and choose **Maximum > Surface Maximum**.
- 2 In the **Settings** window for **Surface Maximum**, locate the **Selection** section.
- 3 From the **Selection** list, choose **Interface Selection**.
- 4 Click **Replace Expression** in the upper-right corner of the **Expressions** section. From the menu, choose **Component: Micromechanics (Local Response) (comp3) > Solid Mechanics > Safety > User defined > solid2.tl1.lemm1.sf1.f_i - User-defined failure index - 1**.
- 5 Locate the **Expressions** section. In the table, enter the following settings:

Expression	Unit	Description
solid2.tl1.lemm1.sf1.f_i	1	User-defined interface failure index

User Defined Failure Indexes at First Material Point in Inner Layer (Study: Micromechanics (Local Response))

- 1 In the **Model Builder** window, click **User Defined Failure Indexes at First Material Point in Inner Layer (Study: Micromechanics (Local Response))**.
- 2 In the **Settings** window for **Evaluation Group**, locate the **Transformation** section.
- 3 Select the **Transpose** checkbox.
- 4 Click to expand the **Format** section. From the **Include parameters** list, choose **Off**.

- 5 In the **User Defined Failure Indexes at First Material Point in Inner Layer (Study: Micromechanics (Local Response))** toolbar, click  **Evaluate**.

User Defined Failure Indexes at First Material Point in Outer Layer (Study: Micromechanics (Local Response))

- 1 Right-click **User Defined Failure Indexes at First Material Point in Inner Layer (Study: Micromechanics (Local Response))** and choose **Duplicate**.
- 2 In the **Settings** window for **Evaluation Group**, type User Defined Failure Indexes at First Material Point in Outer Layer (Study: Micromechanics (Local Response)) in the **Label** text field.
- 3 Locate the **Data** section. From the **Parameter selection (xd)** list, choose **Last**.
- 4 In the **User Defined Failure Indexes at First Material Point in Outer Layer (Study: Micromechanics (Local Response))** toolbar, click  **Evaluate**.