



Model created in COMSOL Multiphysics 6.4

Dome Tweeter with Composite Diaphragm — Frequency-Domain Response

Introduction

Fiber composites are widely used in industrial applications. Compared to more traditional metallic engineering materials, fiber composites often have superior specific stiffness and strength properties. Properties like toughness, stiffness, and weight can often be tailored to specific applications such as a diaphragm in loudspeakers.

Loudspeaker design is a challenging task, where the design objective is to achieve better sound quality without violating manufacturing and operational constraints. The sound quality depends on many parameters, one of them being the ability to control, damp, and shift the diaphragm resonance, and another controlling the diaphragm breakup. Composites can be used to make diaphragms that give a smoother frequency response compared to conventional diaphragm materials like titanium. The ability of composites to break the symmetries in mode shapes and shift resonances can improve the frequency response of a dome tweeter.

This multiphysics example analyzes the frequency response of a tweeter dome. The model uses the **Pressure Acoustic, Frequency Domain** interface of the Acoustic Module in combination with the **Electrical Circuit** interface from the AC/DC Module, the **Solid Mechanics** interface from the Structural Mechanics Module, and the **Layered Shell** interface from the Composite Materials Module.

This example uses composite materials imported from the accompanying Composite Materials Module Application Library model [Dome Tweeter with Composite Diaphragm — Eigenfrequency Analysis](#).



Read more about the Composite Materials Module in the COMSOL blog, [Introduction to the Composite Materials Module](#).

Model Definition

[Figure 1](#) shows the tweeter-dome geometry. For acoustic modeling, the air domains surrounding the tweeter dome also need to be modeled. The model geometry of the tweeter dome is shown in [Figure 2](#). Due to geometry and material symmetries, only one quarter of the geometry is needed for modeling.

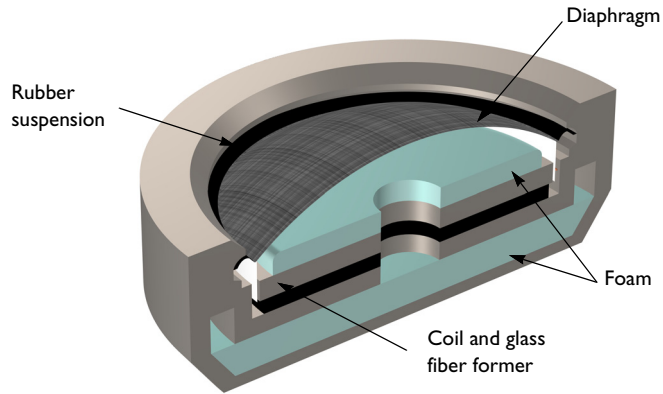

Figure 1: Geometry showing a half section of a tweeter dome.

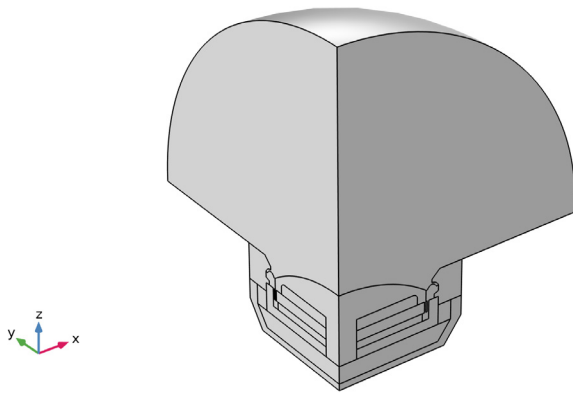

Figure 2: Computational domain corresponding to one quarter of the geometry.

Material Properties

The different components of the tweeter dome use different materials. For the diaphragm, three different materials are tested: two composite materials and one monolithic material, like titanium. The composite properties are computed from a micromechanical analysis

(imported in the model), while the material properties of titanium are taken from the built-in material library. The suspension is made of rubber, with material properties taken from the built-in material library. The former is made of glass fiber and its material properties are noted in [Table 1](#).

TABLE 1: GLASS FIBER MATERIAL PROPERTIES.

Material Property	Value
E	70 GPa
ν	0.33
ρ	2000 kg/m ³

For the surrounding air domains, air from the built-in material library is used. For the soft porous parts of the tweeter, the fluid material is assumed to be air, while the matrix material is assumed to be foam with the material properties listed in [Table 2](#).

TABLE 2: FOAM MATERIAL PROPERTIES.

Material Property	Value
ϵ_p	0.97
R_f	55000 Pa.s/m ²
L_v	41 μ m
L_{th}	117 μ m
τ_∞	2.47

The coil is made of built-in copper material which is available in the material library.

Physics Setup and Boundary Conditions

Each physics interface has different loading and boundary conditions. The voltage is the main driving force of the dome tweeter. The electric physics is modeled by lumped elements using the **Electric Currents** interface. This interface has one ground node and two voltage sources in addition to two resistors and one inductor.

The structural domains are modeled by **Solid Mechanics** and **Layered Shell** interfaces. The common boundaries between these two interfaces are connected through the multiphysics coupling. For the **Solid Mechanics** interface, a body load is applied in the axial direction to account for the magnetic field. For the **Layered Shell** interface, the outer boundaries are fixed.

For the **Pressure Acoustic, Frequency Domain** interface, the exterior boundaries of the air domains are modeled as perfectly matched boundaries. The structural interfaces are coupled to the **Pressure Acoustic, Frequency Domain** interface through multiphysics couplings.

All interfaces except the **Electric Currents** have symmetry boundary conditions.

Results and Discussion

Figure 3 shows the displacement of the diaphragm at 10 kHz with different materials. The displacement magnitude is larger for composite materials due to the lower specific weight. The acoustic pressure profile and sound pressure level computed for different diaphragm materials are shown in Figure 4 and Figure 5, respectively.

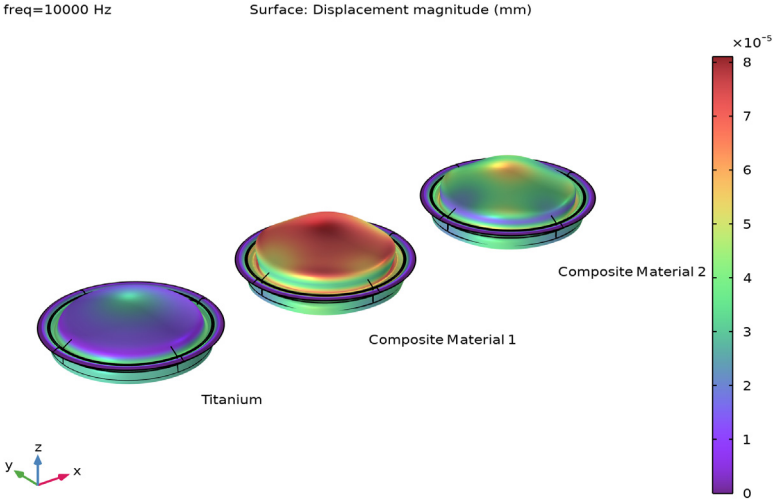

Figure 3: Displacement of the diaphragm.

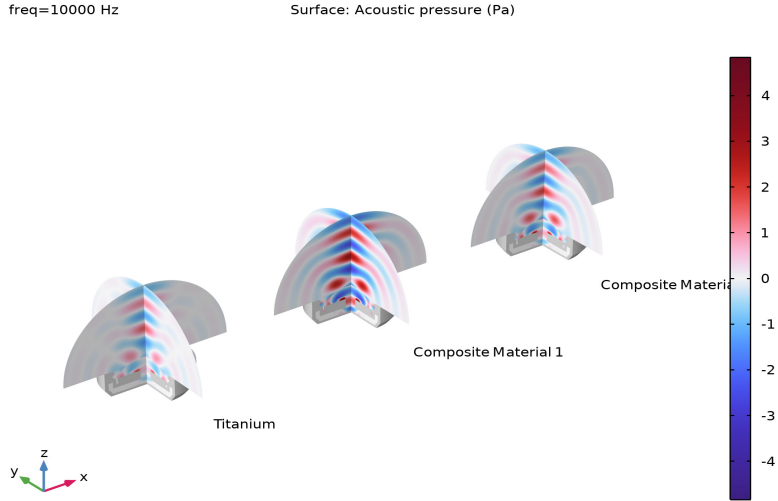

Figure 4: Acoustic pressure profile for different diaphragm materials.

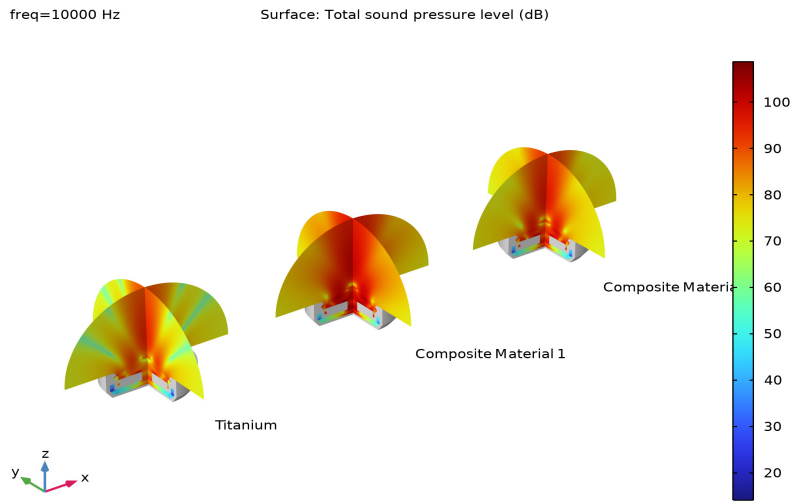

Figure 5: Sound pressure level for different diaphragm materials.

Figure 6 shows frequency-response curves for different diaphragm materials. Note that the continuous curves are obtained by solving the same model for a fine frequency range, while the dotted response is obtained for a coarse frequency range to reduce computation time.

Many important observations can be made from these curves. The first breakup frequency is shifted to higher frequency when using composite materials as compared to titanium. Based on results presented in the model [Dome Tweeter with Composite Diaphragm — Eigenfrequency Analysis](#), the first eigenmodes for the composite materials are antisymmetric and cannot thus be excited by the coil movement, leading to a higher first peak in the sensitivity. This helps to get a smoother frequency-response curve. A smooth frequency response means smoother and higher-quality sound, eliminating trashy sound patterns. So, for a tweeter whose working range is 4–8 kHz, the use of titanium is not advisable as it will give a trashy sound due to the breakup mode being in the same range. Using a composite diaphragm will shift the breakup mode from the working range of the tweeter and give a higher-quality sound. Another advantage of using a composite material for the diaphragm is that it is much lighter than titanium.

The spatial sensitivity analysis of a diaphragm with titanium, composite material 1, and composite material 2 for 10 kHz are shown in [Figure 7](#), [Figure 8](#), and [Figure 9](#), respectively.

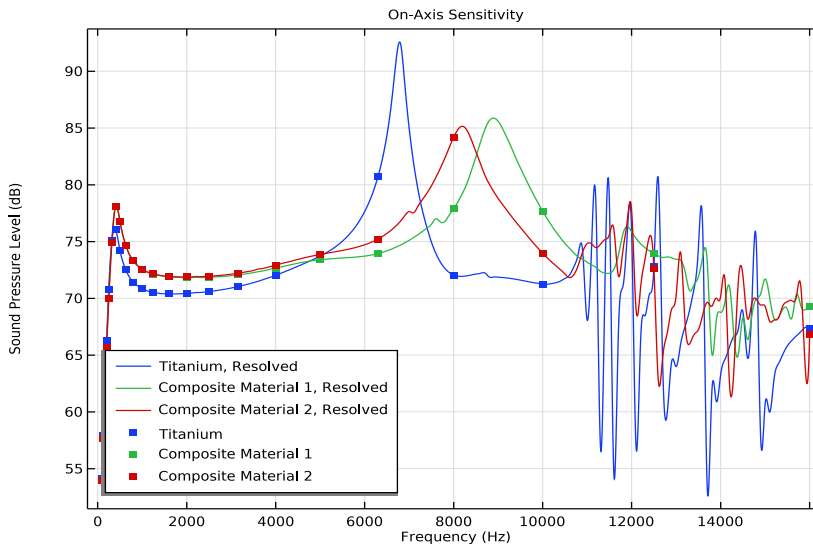

Figure 6: Frequency response curves for different diaphragm materials.

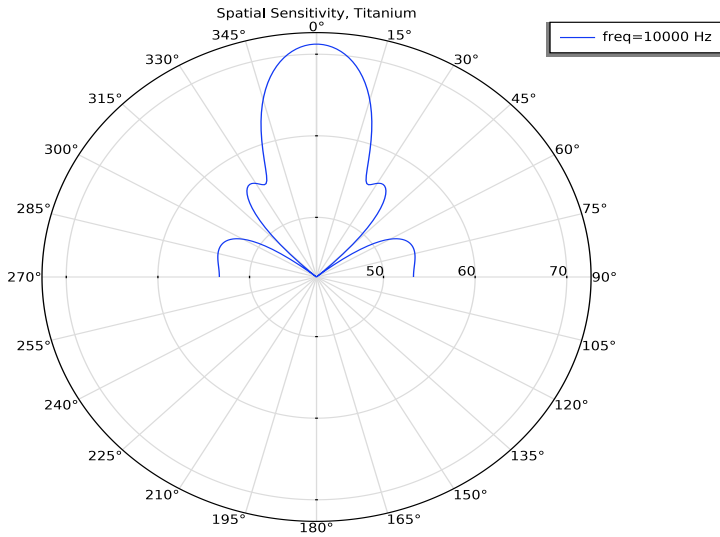

Figure 7: Spatial sensitivity with a diaphragm made of titanium.

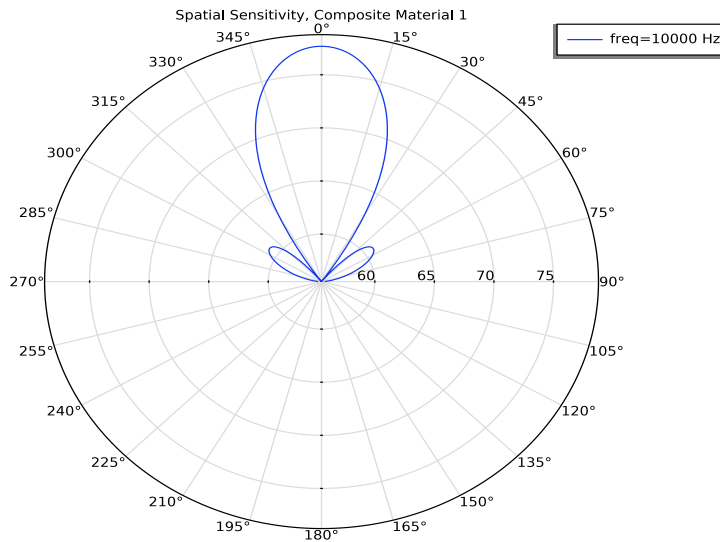

Figure 8: Spatial sensitivity with a diaphragm made of the first composite material.

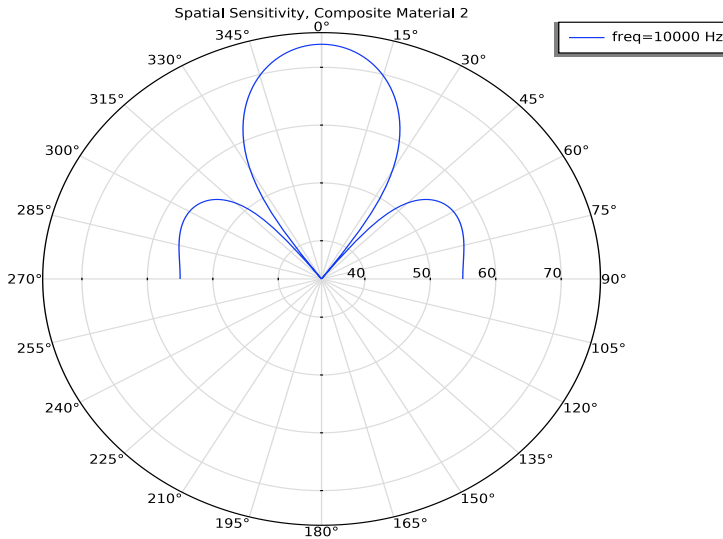

Figure 9: Spatial sensitivity with a diaphragm made of the second composite material.

Notes About the COMSOL Implementation

- Modeling a composite laminate as a layered shell requires a surface geometry, in general referred to as a base surface, and a **Layered Material** node which adds an extra dimension (1D) to the base surface geometry in the surface normal direction. You can use the **Layered Material** functionality to model several layers stacked on top of each other having different thicknesses, material properties, and fiber orientations. You can optionally specify the interface materials between the layers, and control the number of through-thickness mesh elements for each layer.
- The third direction for the selected coordinate system in the **Single Layer Material**, **Layered Material Link**, or **Layered Material Stack** represents the normal direction of the **Layered Shell** or **Shell** physics. This is also the direction in which the layer stacking is interpreted from bottom to top, and therefore, it is crucial to know it during modeling. There are two ways to achieve this:
 - Using physics symbols: Go to the physics settings, find the **Physics Symbols** section, and select the **Enable physics symbols** checkbox. Then go to the material feature, for

instance, **Linear Elastic Material**, to see the normal direction represented by green arrows in the geometry.

- Using result templates: When a solution dataset is available, use the result template **Thickness and Orientation** to plot the normal direction.
- To run the analysis for different layered materials and compare the results, all the layered materials can be defined using a **Switch** node in **Global Materials**. This **Switch** node can be selected in the **Layered Material Link** node and a **Material Sweep** node is added in the study.
- From a constitutive model point of view, you can either use the *Layerwise (LW)* theory based **Layered Shell** interface, or the *Equivalent Single Layer (ESL)* theory based **Linear Elastic Material, Layered** node in the **Shell** interface. The laminated composite presented in the current model is modeled using a **Layered Shell** interface.

Application Library path: Composite_Materials_Module/Multiphysics/
composite_dome_tweeter_freq

Modeling Instructions

From the **File** menu, choose **New**.

NEW

In the **New** window, click  **Model Wizard**.

MODEL WIZARD

- 1 In the **Model Wizard** window, click  **3D**.
- 2 In the **Select Physics** tree, select **Structural Mechanics > Layered Shell (lshell)**.
- 3 Right-click and choose **Add Physics**.
- 4 In the **Select Physics** tree, select **Structural Mechanics > Solid Mechanics (solid)**.
- 5 Right-click and choose **Add Physics**.
- 6 In the **Select Physics** tree, select **Acoustics > Pressure Acoustics > Pressure Acoustics, Frequency Domain (acpr)**.
- 7 Right-click and choose **Add Physics**.
- 8 In the **Select Physics** tree, select **AC/DC > Electrical Circuit (cir)**.
- 9 Right-click and choose **Add Physics**.

10 Click  **Study**.

11 In the **Select Study** tree, select **General Studies > Frequency Domain**.

12 Click  **Done**.

Import the geometric and model parameters from text files.

GLOBAL DEFINITIONS

Geometry Parameters

1 In the **Model Builder** window, under **Global Definitions** click **Parameters I**.

2 In the **Settings** window for **Parameters**, type Geometry Parameters in the **Label** text field.

3 Locate the **Parameters** section. Click  **Load from File**.

4 Browse to the model's Application Libraries folder and double-click the file `composite_dome_tweeter_freq_geom_parameters.txt`.

Model Parameters

1 In the **Home** toolbar, click  **Parameters** and choose **Add > Parameters**.

2 In the **Settings** window for **Parameters**, type Model Parameters in the **Label** text field.

3 Locate the **Parameters** section. Click  **Load from File**.

4 Browse to the model's Application Libraries folder and double-click the file `composite_dome_tweeter_freq_model_parameters.txt`.

Import numerical data for interpolation functions from files.

Interpolation Function: Lp Data

1 In the **Home** toolbar, click  **Functions** and choose **Global > Interpolation**.

2 In the **Settings** window for **Interpolation**, type Interpolation Function: Lp Data in the **Label** text field.

3 Locate the **Definition** section. From the **Data source** list, choose **File**.

4 Click  **Browse**.

5 Browse to the model's Application Libraries folder and double-click the file `composite_dome_tweeter_freq_Lp_data.txt`.

6 Locate the **Data Column Settings** section. In the table, click to select the cell at row number 1 and column number 1.

7 In the **Unit** text field, type Hz.

8 In the table, enter the following settings:

Columns	Type	Settings
Column 2	Function values	Function name=Lp1

9 In the **Name** text field, type Lp1.

10 In the **Unit** text field, type dB.

11 In the table, enter the following settings:

Columns	Type	Settings
Column 3	Function values	Function name=Lp2

12 In the **Name** text field, type Lp2.

13 In the **Unit** text field, type dB.

14 In the table, click to select the cell at row number 4 and column number 1.

15 In the **Name** text field, type Lp3.

16 In the **Unit** text field, type dB.

17 Locate the **Interpolation and Extrapolation** section. From the **Interpolation** list, choose **Cubic spline**.

18 From the **Extrapolation** list, choose **Linear**.

Interpolation Function: Z Data

1 In the **Home** toolbar, click  **Functions** and choose **Global > Interpolation**.

2 In the **Settings** window for **Interpolation**, type Interpolation Function: Z Data in the **Label** text field.

3 Locate the **Definition** section. From the **Data source** list, choose **File**.

4 Click  **Browse**.

5 Browse to the model's Application Libraries folder and double-click the file composite_dome_tweeter_freq_Z_data.txt.

6 Locate the **Data Column Settings** section. In the table, click to select the cell at row number 1 and column number 1.

7 In the **Unit** text field, type Hz.

8 In the table, enter the following settings:



Columns	Type	Settings
Column 2	Function values	Function name=Zabs1

- 9 In the **Name** text field, type Zabs1.
- 10 In the **Unit** text field, type ohm.
- 11 In the table, enter the following settings:

Columns	Type	Settings
Column 3	Function values	Function name=Zabs2

- 12 In the **Name** text field, type Zabs2.
 - 13 In the **Unit** text field, type ohm.
 - 14 In the table, click to select the cell at row number 4 and column number 1.
 - 15 In the **Name** text field, type Zabs3.
 - 16 In the **Unit** text field, type ohm.
 - 17 Locate the **Interpolation and Extrapolation** section. From the **Extrapolation** list, choose **Linear**.
- Define all required materials and layered materials under **Global Definitions > Materials**.

ADD MATERIAL

- 1 In the **Materials** toolbar, click  **Add Material** to open the **Add Material** window.
- 2 Go to the **Add Material** window.
- 3 In the tree, select **Built-in > Air**.
- 4 Right-click and choose **Add to Global Materials**.
- 5 In the tree, select **Built-in > Copper**.
- 6 Right-click and choose **Add to Global Materials**.
- 7 In the tree, select **Built-in > Rubber**.
- 8 Right-click and choose **Add to Global Materials**.
- 9 In the tree, select **Built-in > Titanium beta-21S**.
- 10 Right-click and choose **Add to Global Materials**.
- 11 In the **Materials** toolbar, click  **Add Material** to close the **Add Material** window.

GLOBAL DEFINITIONS

Glass Fiber

- 1 In the **Model Builder** window, under **Global Definitions** right-click **Materials** and choose **Blank Material**.
- 2 In the **Settings** window for **Material**, type Glass Fiber in the **Label** text field.

- 3 Click to expand the **Material Properties** section. In the **Material properties** tree, select **Basic Properties > Density**.
- 4 Right-click and choose **Add to Material**.
- 5 In the **Material properties** tree, select **Basic Properties > Poisson's Ratio**.
- 6 Right-click and choose **Add to Material**.
- 7 In the **Material properties** tree, select **Basic Properties > Young's Modulus**.
- 8 Right-click and choose **Add to Material**.
- 9 Locate the **Material Contents** section. In the table, enter the following settings:

Property	Variable	Value	Unit	Property group
Density	rho	2000 [kg/m ³]	kg/m ³	Basic
Poisson's ratio	nu	0.33		Basic
Young's modulus	E	70 [GPa]	Pa	Basic

Foam

- 1 Right-click **Materials** and choose **Blank Material**.
- 2 In the **Settings** window for **Material**, type Foam in the **Label** text field.
- 3 Click to expand the **Material Properties** section. In the **Material properties** tree, select **Basic Properties > Porosity**.
- 4 Right-click and choose **Add to Material**.
- 5 In the **Material properties** tree, select **Acoustics > Poroacoustics Model > Flow resistivity (Rf)**.
- 6 Right-click and choose **Add This Property Group to Material**.

7 Locate the **Material Contents** section. In the table, enter the following settings:

Property	Variable	Value	Unit	Property group
Porosity	epsilon	0.97		Basic
Flow resistivity	Rf_iso ; Rfii = Rf_iso, Rfij = 0	55000 [Pa* s/m^2]	Pa·s/m ²	Poroacoustics model
Thermal characteristic length	Lth	117 [um]	m	Poroacoustics model
Viscous characteristic length	Lv_iso ; Lvii = Lv_iso, Lvij = 0	41 [um]	m	Poroacoustics model
Tortuosity factor	tau_iso ; tau_ii = tau_iso, tau_ij = 0	2.47		Poroacoustics model

The homogenized composite materials can be imported from an existing Application Library example.

8 In the **Materials** toolbar, click **Import Materials** and choose **Import Materials**.

9 In the **Import Materials** dialog, click  **Browse**.

10 From the **File** menu, choose **Application Libraries**.

11 In the **Application Libraries** window, select **Composite Materials Module > Dynamics and Vibration > composite_dome_tweeter_eigen** in the tree.

12 Click  **Open**.

13 In the **Material** list, choose **Homogeneous Material: RUC 1** and **Homogeneous Material: RUC 2**.

14 Click **OK**.

Layered Material: Rubber

1 Right-click **Materials** and choose **Layered Material**.

2 In the **Settings** window for **Layered Material**, type Layered Material: Rubber in the **Label** text field.

3 Locate the **Layer Definition** section. In the table, enter the following settings:

Layer	Material	Rotation	Value	Thickness	Mesh elements
Layer 1	Rubber (mat3)	0.0	0 rad	th_susp	2

Layered Material: Glass Fiber

- 1 Right-click **Layered Material: Rubber** and choose **Duplicate**.
- 2 In the **Settings** window for **Layered Material**, type Layered Material: Glass Fiber in the **Label** text field.
- 3 Locate the **Layer Definition** section. In the table, enter the following settings:

Layer	Material	Rotation	Value	Thickness	Mesh elements
Layer 1	Glass Fiber (mat5)	0.0	0 rad	th_former	2

Material Switch 1 (sw1)

In the **Model Builder** window, right-click **Materials** and choose **Material Switch**.

Layered Material: Titanium

- 1 In the **Model Builder** window, right-click **Material Switch 1 (sw1)** and choose **Layered Material**.
- 2 In the **Settings** window for **Layered Material**, type Layered Material: Titanium in the **Label** text field.
- 3 Locate the **Layer Definition** section. In the table, enter the following settings:

Layer	Material	Rotation	Value	Thickness	Mesh elements
Layer 1	Titanium beta-21S (mat4)	0.0	0 rad	th_dome	2

Layered Material: Composite Material 1

- 1 Right-click **Layered Material: Titanium** and choose **Duplicate**.
- 2 In the **Settings** window for **Layered Material**, type Layered Material: Composite Material 1 in the **Label** text field.

3 Locate the **Layer Definition** section. In the table, enter the following settings:

Layer	Material	Rotation	Value	Thickness	Mesh elements
Layer 1	Homogeneous Material: RUC 1 (solidcp1mat)	0.0	0 rad	th_dome	2

Layered Material: Composite Material 2

- 1 Right-click **Layered Material: Composite Material 1** and choose **Duplicate**.
- 2 In the **Settings** window for **Layered Material**, type Layered Material: Composite Material 2 in the **Label** text field.
- 3 Locate the **Layer Definition** section. In the table, enter the following settings:





Layer	Material	Rotation	Value	Thickness	Mesh elements
Layer 1	Homogeneous Material: RUC 2 (solid2cp1mat)	0.0	0 rad	th_dome	2

Import the dome tweeter geometry from a file.

GEOMETRY 1

- 1 In the **Model Builder** window, under **Component 1 (comp1)** click **Geometry 1**.
- 2 In the **Settings** window for **Geometry**, locate the **Units** section.
- 3 From the **Length unit** list, choose **mm**.



Import 1 (imp1)

- 1 In the **Geometry** toolbar, click  **Import**.
- 2 In the **Settings** window for **Import**, locate the **Source** section.
- 3 Click  **Browse**.
- 4 Browse to the model's Application Libraries folder and double-click the file composite_dome_tweeter_freq_geom_sequence.mphbin.
- 5 Click  **Import**.
- 6 Click the  **Show Grid** button in the **Graphics** toolbar.



Create explicit selections that are helpful for the model setup.

DEFINITIONS



Acoustic Domains

- 1 In the **Definitions** toolbar, click  **Explicit**.
- 2 In the **Settings** window for **Explicit**, type `Acoustic Domains` in the **Label** text field.
- 3 Locate the **Input Entities** section. Click  **Paste Selection**.
- 4 In the **Paste Selection** dialog, type 2-4, 8, 11 in the **Selection** text field.
- 5 Click **OK**.



Poroacoustics Domains

- 1 In the **Definitions** toolbar, click  **Explicit**.
- 2 In the **Settings** window for **Explicit**, type `Poroacoustics Domains` in the **Label** text field.
- 3 Locate the **Input Entities** section. Click  **Paste Selection**.
- 4 In the **Paste Selection** dialog, type 2, 8 in the **Selection** text field.
- 5 Click **OK**.

Coil Domains

- 1 In the **Definitions** toolbar, click  **Explicit**.
- 2 In the **Settings** window for **Explicit**, type `Coil Domains` in the **Label** text field.
- 3 Locate the **Input Entities** section. Click  **Paste Selection**.
- 4 In the **Paste Selection** dialog, type 9 in the **Selection** text field.
- 5 Click **OK**.

Rubber Boundaries



- 1 In the **Definitions** toolbar, click  **Explicit**.
- 2 In the **Settings** window for **Explicit**, type `Rubber Boundaries` in the **Label** text field.
- 3 Locate the **Input Entities** section. From the **Geometric entity level** list, choose **Boundary**.
- 4 Click  **Paste Selection**.
- 5 In the **Paste Selection** dialog, type 41, 51 in the **Selection** text field.
- 6 Click **OK**.

Glass Fiber Boundaries



- 1 In the **Definitions** toolbar, click  **Explicit**.
- 2 In the **Settings** window for **Explicit**, type `Glass Fiber Boundaries` in the **Label** text field.

- 3 Locate the **Input Entities** section. From the **Geometric entity level** list, choose **Boundary**.
- 4 Click  **Paste Selection**.
- 5 In the **Paste Selection** dialog, type 35, 37 in the **Selection** text field.
- 6 Click **OK**.



Diaphragm Boundaries

- 1 In the **Definitions** toolbar, click  **Explicit**.
- 2 In the **Settings** window for **Explicit**, type Diaphragm Boundaries in the **Label** text field.
- 3 Locate the **Input Entities** section. From the **Geometric entity level** list, choose **Boundary**.
- 4 Click  **Paste Selection**.
- 5 In the **Paste Selection** dialog, type 12, 39 in the **Selection** text field.
- 6 Click **OK**.

Layered Shell Boundaries

- 1 In the **Definitions** toolbar, click  **Union**.
- 2 In the **Settings** window for **Union**, locate the **Geometric Entity Level** section.
- 3 From the **Level** list, choose **Boundary**.
- 4 Locate the **Input Entities** section. Under **Selections to add**, click  **Add**.
- 5 In the **Add** dialog, in the **Selections to add** list, choose **Rubber Boundaries**, **Glass Fiber Boundaries**, and **Diaphragm Boundaries**.
- 6 Click **OK**.
- 7 In the **Settings** window for **Union**, type Layered Shell Boundaries in the **Label** text field.

Perfectly Matched Boundaries



- 1 In the **Definitions** toolbar, click  **Explicit**.
- 2 In the **Settings** window for **Explicit**, type Perfectly Matched Boundaries in the **Label** text field.
- 3 Locate the **Input Entities** section. From the **Geometric entity level** list, choose **Boundary**.
- 4 Click  **Paste Selection**.
- 5 In the **Paste Selection** dialog, type 13 in the **Selection** text field.
- 6 Click **OK**.

Acoustic–Solid Boundaries



- 1 In the **Definitions** toolbar, click  **Explicit**.

- 2 In the **Settings** window for **Explicit**, type Acoustic-Solid Boundaries in the **Label** text field.
- 3 Locate the **Input Entities** section. From the **Geometric entity level** list, choose **Boundary**.
- 4 Click  **Paste Selection**.
- 5 In the **Paste Selection** dialog, type 35, 36, 38, 40 in the **Selection** text field.
- 6 Click **OK**.



Acoustic-Layered Shell Boundaries

- 1 In the **Definitions** toolbar, click  **Explicit**.
- 2 In the **Settings** window for **Explicit**, type Acoustic-Layered Shell Boundaries in the **Label** text field.
- 3 Locate the **Input Entities** section. From the **Geometric entity level** list, choose **Boundary**.
- 4 Click  **Paste Selection**.
- 5 In the **Paste Selection** dialog, type 12, 35, 37, 39, 41, 51 in the **Selection** text field.
- 6 Click **OK**.

Fixed Boundaries

- 1 In the **Definitions** toolbar, click  **Explicit**.
- 2 In the **Settings** window for **Explicit**, type Fixed Boundaries in the **Label** text field.
- 3 Locate the **Input Entities** section. From the **Geometric entity level** list, choose **Boundary**.
- 4 Click  **Paste Selection**.
- 5 In the **Paste Selection** dialog, type 51 in the **Selection** text field.
- 6 Click **OK**.

Symmetry Boundaries

- 1 In the **Definitions** toolbar, click  **Explicit**.
- 2 In the **Settings** window for **Explicit**, type Symmetry Boundaries in the **Label** text field.
- 3 Locate the **Input Entities** section. From the **Geometric entity level** list, choose **Boundary**.
- 4 Click  **Paste Selection**.
- 5 In the **Paste Selection** dialog, type 1 2 4 5 7 8 10 11 14 17 20 23 34 44 53 66 67 68 69 70 71 72 in the **Selection** text field.
- 6 Click **OK**.

Symmetry Edges

- 1 In the **Definitions** toolbar, click  **Explicit**.
- 2 In the **Settings** window for **Explicit**, type Symmetry Edges in the **Label** text field.

- 3 Locate the **Input Entities** section. From the **Geometric entity level** list, choose **Edge**.
- 4 Click  **Paste Selection**.
- 5 In the **Paste Selection** dialog, type 12, 13, 44, 47, 50, 55, 116, 118, 120, 122 in the **Selection** text field.
- 6 Click **OK**.

Define the variables needed for the **Electrical Circuit** interface in a **Variable** node.

Average I (aveopI)

- 1 In the **Definitions** toolbar, click  **Nonlocal Couplings** and choose **Average**.
- 2 In the **Settings** window for **Average**, locate the **Source Selection** section.
- 3 From the **Selection** list, choose **Coil Domains**.

Variables I

- 1 In the **Model Builder** window, right-click **Definitions** and choose **Variables**.
- 2 In the **Settings** window for **Variables**, locate the **Variables** section.
- 3 In the table, enter the following settings:

Name	Expression	Unit	Description
L_E	$(L_e / (\sin(n_e \pi / 2))) * (\text{acpr}.\omega[\text{s/rad}]^{(n_e - 1)})$	H	Voice coil inductance (frequency dependent)
Rp_E	$(L_e / (\cos(n_e \pi / 2))) * (\text{acpr}.\omega[\text{s/rad}]^{(n_e)} [\text{ohm/H}])$	Ω	Resistance (losses in magnetic system)
v0	aveop1(solid.u_tZ)	m/s	Voice coil velocity

MATERIALS

Material Link: Air

- 1 In the **Model Builder** window, under **Component 1 (comp1)** right-click **Materials** and choose **More Materials > Material Link**.
- 2 In the **Settings** window for **Material Link**, type Material Link: Air in the **Label** text field.
- 3 Locate the **Geometric Entity Selection** section. From the **Selection** list, choose **Acoustic Domains**.

Material Link: Copper

- 1 Right-click **Material Link: Air** and choose **Duplicate**.

- 2 In the **Settings** window for **Material Link**, type Material Link: Copper in the **Label** text field.
- 3 Locate the **Geometric Entity Selection** section. From the **Selection** list, choose **Coil Domains**.
- 4 Locate the **Link Settings** section. From the **Material** list, choose **Copper (mat2)**.

Layered Material Link: Rubber

- 1 In the **Model Builder** window, right-click **Materials** and choose **Layers > Layered Material Link**.
- 2 In the **Settings** window for **Layered Material Link**, type Layered Material Link: Rubber in the **Label** text field.
- 3 Locate the **Boundary Selection** section. From the **Selection** list, choose **Rubber Boundaries**.
- 4 Locate the **Orientation and Position** section. From the **Position** list, choose **Top side on boundary**.

Layered Material Link: Glass Fiber

- 1 Right-click **Layered Material Link: Rubber** and choose **Duplicate**.
- 2 In the **Settings** window for **Layered Material Link**, type Layered Material Link: Glass Fiber in the **Label** text field.
- 3 Locate the **Boundary Selection** section. From the **Selection** list, choose **Glass Fiber Boundaries**.
- 4 Locate the **Layered Material Settings** section. From the **Material** list, choose **Layered Material: Glass Fiber (lmat2)**.

Layered Material Link: Diaphragm

- 1 Right-click **Layered Material Link: Glass Fiber** and choose **Duplicate**.
- 2 In the **Settings** window for **Layered Material Link**, type Layered Material Link: Diaphragm in the **Label** text field.
- 3 Locate the **Boundary Selection** section. From the **Selection** list, choose **Diaphragm Boundaries**.
- 4 Locate the **Layered Material Settings** section. From the **Material** list, choose **Material Switch I (sw1)**.
- 5 Locate the **Orientation and Position** section. Click  **Go to Source** for **Coordinate system**.

DEFINITIONS (COMPI)

Boundary System 1 (sys1)

- 1 In the **Model Builder** window, under **Component 1 (comp1) > Definitions** click **Boundary System 1 (sys1)**.
- 2 In the **Settings** window for **Boundary System**, locate the **Settings** section.
- 3 Find the **Coordinate names** subsection. From the **Axis** list, choose **x**.

LAYERED SHELL (LSHELL)

- 1 In the **Model Builder** window, under **Component 1 (comp1)** click **Layered Shell (lshell)**.
- 2 In the **Settings** window for **Layered Shell**, locate the **Boundary Selection** section.
- 3 From the **Selection** list, choose **Layered Shell Boundaries**.

Linear Elastic Material 1

- 1 In the **Model Builder** window, under **Component 1 (comp1) > Layered Shell (lshell)** click **Linear Elastic Material 1**.
- 2 In the **Settings** window for **Linear Elastic Material**, locate the **Linear Elastic Material** section.
- 3 From the **Material symmetry** list, choose **Anisotropic**.

Damping 1

- 1 In the **Physics** toolbar, click  **Attributes** and choose **Damping**.
- 2 In the **Settings** window for **Damping**, locate the **Boundary Selection** section.
- 3 From the **Selection** list, choose **Rubber Boundaries**.
- 4 Locate the **Damping Settings** section. In the β_{dK} text field, type $0.46/\omega_{loss}$.

Continuity 1

- 1 In the **Physics** toolbar, click  **Edges** and choose **Continuity**.
- 2 In the **Settings** window for **Continuity**, locate the **Layer Selection** section.
- 3 From the **Source** list, choose **Layered Material Link: Diaphragm (lmat3)**.
- 4 From the **Destination** list, choose **Layered Material Link: Glass Fiber (lmat2)**.
- 5 In the **Selection** table, enter the following settings:

	Layered material	Offset (m)
√	Layered Material: Glass Fiber (lmat2)	0

Continuity 2

- 1 Right-click **Continuity 1** and choose **Duplicate**.

- 2 In the **Settings** window for **Continuity**, locate the **Layer Selection** section.
- 3 From the **Destination** list, choose **Layered Material Link: Rubber (lmat1)**.
- 4 In the **Selection** table, enter the following settings:

	Layered material	Offset (m)
√	Layered Material: Rubber (lmat1)	0

Fixed Constraint 1

- 1 In the **Physics** toolbar, click  **Boundaries** and choose **Fixed Constraint**.
- 2 In the **Settings** window for **Fixed Constraint**, locate the **Boundary Selection** section.
- 3 From the **Selection** list, choose **Fixed Boundaries**.

Symmetry

- 1 In the **Physics** toolbar, click  **Edges** and choose **Symmetry**.
- 2 In the **Settings** window for **Symmetry**, type Symmetry in the **Label** text field.
- 3 Locate the **Edge Selection** section. From the **Selection** list, choose **Symmetry Edges**.

SOLID MECHANICS (SOLID)

- 1 In the **Model Builder** window, under **Component 1 (comp1)** click **Solid Mechanics (solid)**.
- 2 In the **Settings** window for **Solid Mechanics**, locate the **Domain Selection** section.
- 3 From the **Selection** list, choose **Coil Domains**.

Body Load 1

- 1 In the **Physics** toolbar, click  **Domains** and choose **Body Load**.
- 2 In the **Settings** window for **Body Load**, locate the **Domain Selection** section.
- 3 From the **Selection** list, choose **All domains**.
- 4 Locate the **Force** section. From the **Load type** list, choose **Total force**.
- 5 Specify the \mathbf{F}_{tot} vector as

0.25*BL*cir.R1.i	z
------------------	---

Symmetry

- 1 In the **Physics** toolbar, click  **Boundaries** and choose **Symmetry**.
- 2 In the **Settings** window for **Symmetry**, type Symmetry in the **Label** text field.
- 3 Locate the **Boundary Selection** section. From the **Selection** list, choose **Symmetry Boundaries**.

PRESSURE ACOUSTICS, FREQUENCY DOMAIN (ACPR)

- 1 In the **Model Builder** window, under **Component 1 (comp1)** click **Pressure Acoustics, Frequency Domain (acpr)**.
- 2 In the **Settings** window for **Pressure Acoustics, Frequency Domain**, locate the **Domain Selection** section.
- 3 From the **Selection** list, choose **Acoustic Domains**.

Poroacoustics 1

- 1 In the **Physics** toolbar, click  **Domains** and choose **Poroacoustics**.
- 2 In the **Settings** window for **Poroacoustics**, locate the **Domain Selection** section.
- 3 From the **Selection** list, choose **Poroacoustics Domains**.
- 4 Locate the **Poroacoustics Model** section. From the **Poroacoustics model** list, choose **Johnson–Champoux–Allard (JCA)**.
- 5 Locate the **Porous Matrix Properties** section. From the **Porous elastic material** list, choose **Foam (mat6)**.

Perfectly Matched Boundary 1

- 1 In the **Physics** toolbar, click  **Boundaries** and choose **Perfectly Matched Boundary**.
- 2 In the **Settings** window for **Perfectly Matched Boundary**, locate the **Boundary Selection** section.
- 3 From the **Selection** list, choose **Perfectly Matched Boundaries**.

Exterior Field Calculation 1

- 1 In the **Physics** toolbar, click  **Boundaries** and choose **Exterior Field Calculation**.
- 2 In the **Settings** window for **Exterior Field Calculation**, locate the **Boundary Selection** section.
- 3 From the **Selection** list, choose **Perfectly Matched Boundaries**.
- 4 Locate the **Exterior Field Calculation** section. From the **Symmetry type** list, choose **Sector symmetry with one symmetry plane**.
- 5 From the **Transformation** list, choose **Rotation and reflection**.
- 6 In the n text field, type 4.

Symmetry

- 1 In the **Physics** toolbar, click  **Boundaries** and choose **Symmetry**.
- 2 In the **Settings** window for **Symmetry**, type Symmetry in the **Label** text field.
- 3 Locate the **Boundary Selection** section. From the **Selection** list, choose **Symmetry Boundaries**.

ELECTRICAL CIRCUIT (CIR)

In the **Model Builder** window, under **Component 1 (comp1)** click **Electrical Circuit (cir)**.

Voltage Source 1 (V1)

- 1 In the **Electrical Circuit** toolbar, click  **Voltage Source**.
- 2 In the **Settings** window for **Voltage Source**, locate the **Node Connections** section.
- 3 In the table, enter the following settings:

Label	Node names
n	0

- 4 Locate the **Device Parameters** section. In the v_{src} text field, type V_0 .

Resistor 1 (R1)

- 1 In the **Electrical Circuit** toolbar, click  **Resistor**.
- 2 In the **Settings** window for **Resistor**, locate the **Node Connections** section.
- 3 In the table, enter the following settings:

Label	Node names
p	1
n	2

- 4 Locate the **Device Parameters** section. In the R text field, type R_E .

Inductor 1 (L1)

- 1 In the **Electrical Circuit** toolbar, click  **Inductor**.
- 2 In the **Settings** window for **Inductor**, locate the **Node Connections** section.
- 3 In the table, enter the following settings:

Label	Node names
p	2
n	3

- 4 Locate the **Device Parameters** section. In the L text field, type L_E .

Resistor 2 (R2)

- 1 In the **Electrical Circuit** toolbar, click  **Resistor**.
- 2 In the **Settings** window for **Resistor**, locate the **Node Connections** section.

3 In the table, enter the following settings:

Label	Node names
p	2
n	3

4 Locate the **Device Parameters** section. In the R text field, type Rp_E .

Voltage Source 2 (V2)

1 In the **Electrical Circuit** toolbar, click  **Voltage Source**.

2 In the **Settings** window for **Voltage Source**, locate the **Node Connections** section.

3 In the table, enter the following settings:

Label	Node names
p	3
n	0

4 Locate the **Device Parameters** section. In the v_{src} text field, type $BL*v0$.

MULTIPHYSICS

Layered Shell–Structure Cladding 1 (Issc1)

In the **Model Builder** window, under **Component 1 (comp1)** right-click **Multiphysics** and choose **Layered Shell–Structure Cladding**.

Acoustic–Solid Boundary

1 In the **Model Builder** window, right-click **Multiphysics** and choose **Acoustic–Structure Boundary**.

2 In the **Settings** window for **Acoustic–Structure Boundary**, type **Acoustic-Solid Boundary** in the **Label** text field.

3 Locate the **Coupled Interfaces** section. From the **Structure** list, choose **Solid Mechanics (solid)**.

4 Locate the **Boundary Selection** section. From the **Selection** list, choose **Acoustic–Solid Boundaries**.

Acoustic–Layered Shell Boundary

1 Right-click **Multiphysics** and choose **Acoustic–Structure Boundary**.

2 In the **Settings** window for **Acoustic–Structure Boundary**, type **Acoustic-Layered Shell Boundary** in the **Label** text field.

- 3 Locate the **Boundary Selection** section. From the **Selection** list, choose **Acoustic-Layered Shell Boundaries**.

Create a customized mesh sequence using the **User-controlled mesh** option in the **Sequence Type** section.

MESH 1

Free Triangular 1

- 1 In the **Mesh** toolbar, click  **More Generators** and choose **Free Triangular**.
- 2 In the **Settings** window for **Free Triangular**, locate the **Boundary Selection** section.
- 3 From the **Selection** list, choose **Layered Shell Boundaries**.

Size 1

- 1 Right-click **Free Triangular 1** and choose **Size**.
- 2 In the **Settings** window for **Size**, locate the **Element Size** section.
- 3 Click the **Custom** button.
- 4 Locate the **Geometric Entity Selection** section. From the **Selection** list, choose **Diaphragm Boundaries**.
- 5 Locate the **Element Size Parameters** section.
- 6 Select the **Maximum element size** checkbox. In the associated text field, type 1 [mm].
- 7 Select the **Minimum element size** checkbox. In the associated text field, type 1 [mm].

Size 2

- 1 Right-click **Size 1** and choose **Duplicate**.
- 2 In the **Settings** window for **Size**, locate the **Geometric Entity Selection** section.
- 3 From the **Selection** list, choose **Rubber Boundaries**.

Size 3

- 1 Right-click **Size 2** and choose **Duplicate**.
- 2 In the **Settings** window for **Size**, locate the **Geometric Entity Selection** section.
- 3 From the **Selection** list, choose **Glass Fiber Boundaries**.
- 4 Locate the **Element Size Parameters** section. In the **Maximum element size** text field, type 4 [mm].

Swept 1

- 1 In the **Mesh** toolbar, click  **Swept**.
- 2 In the **Settings** window for **Swept**, locate the **Domain Selection** section.

3 From the **Geometric entity level** list, choose **Domain**.

4 From the **Selection** list, choose **Coil Domains**.

Free Tetrahedral I

In the **Mesh** toolbar, click  **Free Tetrahedral**.

Boundary Layers I

1 In the **Mesh** toolbar, click  **Boundary Layers**.

2 In the **Settings** window for **Boundary Layers**, locate the **Geometric Entity Selection** section.

3 From the **Geometric entity level** list, choose **Domain**.

4 Select Domain 4 only.

Boundary Layer Properties

1 In the **Model Builder** window, click **Boundary Layer Properties**.

2 In the **Settings** window for **Boundary Layer Properties**, locate the **Boundary Selection** section.

3 From the **Selection** list, choose **Perfectly Matched Boundaries**.

4 Locate the **Layers** section. In the **Number of layers** text field, type 1.

Size

1 In the **Model Builder** window, under **Component 1 (comp1) > Mesh 1** click **Size**.

2 In the **Settings** window for **Size**, locate the **Element Size** section.

3 Click the **Custom** button.

4 Locate the **Element Size Parameters** section. In the **Maximum element size** text field, type $1\text{mm}/6$.

5 In the **Minimum element size** text field, type $2[\text{mm}]$.

6 In the **Curvature factor** text field, type 0.5.

7 Click  **Build All**.



STUDY: FREQUENCY RESPONSE

1 In the **Model Builder** window, click **Study 1**.

2 In the **Settings** window for **Study**, type Study: Frequency Response in the **Label** text field.

3 Locate the **Study Settings** section. Clear the **Generate default plots** checkbox.

Material Sweep

- 1 In the **Study** toolbar, click  **More Study Extensions** and choose **Material Sweep**.
- 2 In the **Settings** window for **Material Sweep**, locate the **Study Settings** section.
- 3 Click  **Add**.

Step 1: Frequency Domain

- 1 In the **Model Builder** window, click **Step 1: Frequency Domain**.
- 2 In the **Settings** window for **Frequency Domain**, locate the **Study Settings** section.
- 3 Click  **Range**.
- 4 In the **Range** dialog, choose **ISO preferred frequencies** from the **Entry method** list.
- 5 From the **Interval** list, choose **1/3 octave**.
- 6 In the **Start frequency** text field, type 100.
- 7 In the **Stop frequency** text field, type 16000.
- 8 Click **Replace**.
- 9 In the **Settings** window for **Frequency Domain**, locate the **Study Settings** section.
- 10 From the **Tolerance** list, choose **User controlled**.
- 11 In the **Relative tolerance** text field, type 0.0001.

Create a customized solver sequence to improve convergence.

Solution 1 (sol1)

- 1 In the **Study** toolbar, click  **Show Default Solver**.
- 2 In the **Model Builder** window, expand the **Solution 1 (sol1)** node.
- 3 In the **Model Builder** window, expand the **Study: Frequency Response > Solver Configurations > Solution 1 (sol1) > Stationary Solver 1** node.
- 4 Right-click **Study: Frequency Response > Solver Configurations > Solution 1 (sol1) > Stationary Solver 1 > Suggested Iterative Solver (GMRES with GMG and Direct Precond.) (asb1_asb2)** and choose **Enable**.
- 5 In the **Settings** window for **Iterative**, locate the **General** section.
- 6 In the **Number of iterations before restart** text field, type 300.
- 7 From the **Preconditioning** list, choose **Right**.
- 8 In the **Model Builder** window, expand the **Study: Frequency Response > Solver Configurations > Solution 1 (sol1) > Stationary Solver 1 >**

Suggested Iterative Solver (GMRES with GMG and Direct Precond.) (asb1_asb2) node, then click **Direct Preconditioner I**.

- 9 In the **Settings** window for **Direct Preconditioner**, locate the **General** section.
- 10 From the **Solver** list, choose **PARDISO**.
- 11 Click to expand the **Hybridization** section. Under **Preconditioner variables**, click **+ Add**.
- 12 In the **Add** dialog, in the **Preconditioner variables** list, choose **Voltages (compl.voltages)**, **Currents (compl.currents)**, and **Currents, Time Derivatives (compl.current_time)**.
- 13 Click **OK**.
- 14 In the **Study** toolbar, click **= Compute**.

RESULTS

- 1 In the **Model Builder** window, click **Results**.
- 2 In the **Settings** window for **Results**, locate the **Update of Results** section.
- 3 Select the **Only plot when requested** checkbox.

RESULT TEMPLATES

- 1 From the **Windows** menu, choose **Result Templates**.
- 2 Go to the **Result Templates** window.
- 3 In the tree, select **Study: Frequency Response/Parametric Solutions I (sol2) > Layered Shell > Displacement (Ishell)**.
- 4 Click the **Add Result Template** button in the window toolbar.
- 5 From the **Results** menu, choose **Result Templates**.

RESULTS

Sector 3D I

- 1 In the **Model Builder** window, expand the **Results** node.
- 2 Right-click **Results > Datasets** and choose **More 3D Datasets > Sector 3D**.
- 3 In the **Settings** window for **Sector 3D**, locate the **Data** section.
- 4 From the **Dataset** list, choose **Layered Material**.
- 5 Locate the **Symmetry** section. In the **Number of sectors** text field, type 4.
- 6 From the **Transformation** list, choose **Rotation and reflection**.

Diaphragm Displacement (Ishell)

- 1 In the **Model Builder** window, under **Results** click **Displacement (Ishell)**.

- 2 In the **Settings** window for **3D Plot Group**, type Diaphragm Displacement (Ishell) in the **Label** text field.
- 3 Locate the **Data** section. From the **Dataset** list, choose **Sector 3D I**.
- 4 From the **Material Switch 1** list, choose **Layered Material: Titanium**.
- 5 From the **Parameter value (freq (Hz))** list, choose **10000**.
- 6 Click to expand the **Title** section. From the **Title type** list, choose **Manual**.
- 7 In the **Title** text area, type Surface: Displacement magnitude (mm).
- 8 In the **Parameter indicator** text field, type freq=10000 Hz.
- 9 Click to expand the **Plot Array** section. From the **Array type** list, choose **Linear**.

Surface 2

- 1 In the **Model Builder** window, expand the **Diaphragm Displacement (Ishell)** node.
- 2 Right-click **Results > Diaphragm Displacement (Ishell) > Surface 1** and choose **Duplicate**.
- 3 In the **Settings** window for **Surface**, locate the **Data** section.
- 4 From the **Dataset** list, choose **Sector 3D I**.
- 5 From the **Material Switch 1** list, choose **Layered Material: Composite Material 1**.
- 6 From the **Parameter value (freq (Hz))** list, choose **10000**.
- 7 Click to expand the **Inherit Style** section. From the **Plot** list, choose **Surface 1**.

Surface 3

- 1 Right-click **Surface 2** and choose **Duplicate**.
- 2 In the **Settings** window for **Surface**, locate the **Data** section.
- 3 From the **Material Switch 1** list, choose **Layered Material: Composite Material 2**.

Diaphragm Displacement (Ishell)

In the **Model Builder** window, click **Diaphragm Displacement (Ishell)**.

Table Annotation 1



- 1 In the **Diaphragm Displacement (Ishell)** toolbar, click  **More Plots** and choose **Table Annotation**.
- 2 In the **Settings** window for **Table Annotation**, locate the **Data** section.
- 3 From the **Source** list, choose **Local table**.

4 In the table, enter the following settings:

x-coordinate	y-coordinate	z-coordinate	Annotation
-20[mm]	-80[mm]	0	Titanium
80[mm]	-80[mm]	0	Composite Material 1
200[mm]	-80[mm]	0	Composite Material 2

5 Locate the **Coloring and Style** section. Clear the **Show point** checkbox.

Diaphragm Displacement (Ishell)

- 1 In the **Model Builder** window, click **Diaphragm Displacement (Ishell)**.
- 2 In the **Diaphragm Displacement (Ishell)** toolbar, click  **Plot**.
- 3 Click the  **Show Grid** button in the **Graphics** toolbar.
- 4 Click the  **Zoom Extents** button in the **Graphics** toolbar.

Mirror 3D 1

- 1 In the **Results** toolbar, click  **More Datasets** and choose **Mirror 3D**.
- 2 In the **Settings** window for **Mirror 3D**, locate the **Data** section.
- 3 From the **Dataset** list, choose **Study: Frequency Response/Parametric Solutions 1 (sol2)**.

Mirror 3D 2

- 1 Right-click **Mirror 3D 1** and choose **Duplicate**.
- 2 In the **Settings** window for **Mirror 3D**, locate the **Data** section.
- 3 From the **Dataset** list, choose **Mirror 3D 1**.
- 4 Locate the **Plane Data** section. From the **Plane** list, choose **xz-planes**.

Acoustic Pressure (acpr)

- 1 In the **Results** toolbar, click  **3D Plot Group**.
- 2 In the **Settings** window for **3D Plot Group**, type Acoustic Pressure (acpr) in the **Label** text field.
- 3 Locate the **Data** section. From the **Dataset** list, choose **Mirror 3D 2**.
- 4 From the **Material Switch 1** list, choose **Layered Material: Titanium**.
- 5 From the **Parameter value (freq (Hz))** list, choose **10000**.
- 6 Locate the **Title** section. From the **Title type** list, choose **Manual**.
- 7 In the **Title** text area, type Surface: Acoustic pressure (Pa).
- 8 In the **Parameter indicator** text field, type freq=10000 Hz.
- 9 Locate the **Plot Settings** section. Clear the **Plot dataset edges** checkbox.

10 Locate the **Plot Array** section. From the **Array type** list, choose **Linear**.

Multislice 1

- 1 In the **Acoustic Pressure (acpr)** toolbar, click  **More Plots** and choose **Multislice**.
- 2 In the **Settings** window for **Multislice**, locate the **Expression** section.
- 3 In the **Expression** text field, type `acpr.p_t`.
- 4 Locate the **Multipane Data** section. Find the **z-planes** subsection. In the **Planes** text field, type 0.
- 5 Locate the **Coloring and Style** section. From the **Color table** list, choose **Wave**.
- 6 From the **Scale** list, choose **Linear symmetric**.

Multislice 2

- 1 Right-click **Multislice 1** and choose **Duplicate**.
- 2 In the **Settings** window for **Multislice**, locate the **Data** section.
- 3 From the **Dataset** list, choose **Mirror 3D 2**.
- 4 From the **Material Switch 1** list, choose **Layered Material: Composite Material 1**.
- 5 From the **Parameter value (freq (Hz))** list, choose **10000**.
- 6 Click to expand the **Inherit Style** section. From the **Plot** list, choose **Multislice 1**.

Multislice 3

- 1 Right-click **Multislice 2** and choose **Duplicate**.
- 2 In the **Settings** window for **Multislice**, locate the **Data** section.
- 3 From the **Material Switch 1** list, choose **Layered Material: Composite Material 2**.

Volume 1

In the **Model Builder** window, right-click **Acoustic Pressure (acpr)** and choose **Volume**.

Sector 3D 2

- 1 In the **Model Builder** window, under **Results > Datasets** right-click **Sector 3D 1** and choose **Duplicate**.
- 2 In the **Settings** window for **Sector 3D**, locate the **Data** section.
- 3 From the **Dataset** list, choose **Study: Frequency Response/Parametric Solutions 1 (sol2)**.
- 4 Locate the **Symmetry** section. From the **Sectors to include** list, choose **Manual**.
- 5 In the **Number of sectors to include** text field, type 3.
- 6 In the **Start sector** text field, type 3.

Volume 1

- 1 In the **Model Builder** window, under **Results > Acoustic Pressure (acpr)** click **Volume 1**.
- 2 In the **Settings** window for **Volume**, locate the **Data** section.
- 3 From the **Dataset** list, choose **Sector 3D 2**.
- 4 Locate the **Expression** section. In the **Expression** text field, type 1.
- 5 Locate the **Coloring and Style** section. From the **Coloring** list, choose **Uniform**.
- 6 From the **Color** list, choose **Gray**.
- 7 Click to expand the **Plot Array** section. Select the **Manual indexing** checkbox.

Selection 1

- 1 Right-click **Volume 1** and choose **Selection**.
- 2 In the **Settings** window for **Selection**, locate the **Selection** section.
- 3 Click  **Paste Selection**.
- 4 In the **Paste Selection** dialog, type 1, 5-7, 10 in the **Selection** text field.
- 5 Click **OK**.

Volume 2

- 1 Right-click **Volume 1** and choose **Duplicate**.
- 2 In the **Settings** window for **Volume**, locate the **Plot Array** section.
- 3 In the **Index** text field, type 1.

Volume 3

Right-click **Volume 2** and choose **Duplicate**.

Volume 1

In the **Model Builder** window, collapse the **Results > Acoustic Pressure (acpr) > Volume 1** node.

Volume 3

- 1 In the **Model Builder** window, click **Volume 3**.
- 2 In the **Settings** window for **Volume**, locate the **Plot Array** section.
- 3 In the **Index** text field, type 2.

Acoustic Pressure (acpr)

In the **Model Builder** window, click **Acoustic Pressure (acpr)**.



Table Annotation 1

- 1 In the **Acoustic Pressure (acpr)** toolbar, click  **More Plots** and choose **Table Annotation**.
- 2 In the **Settings** window for **Table Annotation**, locate the **Data** section.
- 3 From the **Source** list, choose **Local table**.
- 4 In the table, enter the following settings:

x-coordinate	y-coordinate	z-coordinate	Annotation
-20[mm]	-140[mm]	0	Titanium
260[mm]	-140[mm]	0	Composite Material 1
540[mm]	-140[mm]	0	Composite Material 2

- 5 Locate the **Coloring and Style** section. Clear the **Show point** checkbox.

Acoustic Pressure (acpr)

- 1 In the **Model Builder** window, click **Acoustic Pressure (acpr)**.
- 2 In the **Acoustic Pressure (acpr)** toolbar, click  **Plot**.
- 3 Click the  **Show Grid** button in the **Graphics** toolbar.
- 4 Click the  **Zoom Extents** button in the **Graphics** toolbar.

Sound Pressure Level (acpr)

- 1 Right-click **Acoustic Pressure (acpr)** and choose **Duplicate**.
- 2 In the **Settings** window for **3D Plot Group**, type Sound Pressure Level (acpr) in the **Label** text field.
- 3 Locate the **Title** section. In the **Title** text area, type Surface: Total sound pressure level (dB).

Multislice 1

- 1 In the **Model Builder** window, expand the **Sound Pressure Level (acpr)** node, then click **Multislice 1**.
- 2 In the **Settings** window for **Multislice**, locate the **Expression** section.
- 3 In the **Expression** text field, type `acpr.Lp_t`.
- 4 Locate the **Coloring and Style** section. From the **Color table** list, choose **Rainbow**.
- 5 From the **Scale** list, choose **Linear**.

Multislice 2

- 1 In the **Model Builder** window, click **Multislice 2**.
- 2 In the **Settings** window for **Multislice**, locate the **Expression** section.

3 In the **Expression** text field, type `acpr.Lp_t`.

Multislice 3

- 1** In the **Model Builder** window, click **Multislice 3**.
- 2** In the **Settings** window for **Multislice**, locate the **Expression** section.
- 3** In the **Expression** text field, type `acpr.Lp_t`.

Sound Pressure Level (acpr)

- 1** In the **Model Builder** window, click **Sound Pressure Level (acpr)**.
- 2** In the **Sound Pressure Level (acpr)** toolbar, click  **Plot**.

GLOBAL DEFINITIONS

Interpolation Function: Lp Data (Lp1, Lp2, Lp3)

- 1** In the **Model Builder** window, under **Global Definitions** click **Interpolation Function: Lp Data (Lp1, Lp2, Lp3)**.
- 2** In the **Settings** window for **Interpolation**, click  **Create Plot**.

RESULTS

Grid ID 1

- 1** In the **Settings** window for **Grid ID**, locate the **Parameter Bounds** section.
- 2** In the **Minimum** text field, type 100.
- 3** In the **Maximum** text field, type 16000.

GLOBAL DEFINITIONS

Interpolation Function: Z Data (Zabs1, Zabs2, Zabs3)

- 1** In the **Model Builder** window, under **Global Definitions** click **Interpolation Function: Z Data (Zabs1, Zabs2, Zabs3)**.
- 2** In the **Settings** window for **Interpolation**, click  **Create Plot**.

RESULTS

Grid ID 1a

- 1** In the **Settings** window for **Grid ID**, locate the **Parameter Bounds** section.
- 2** In the **Minimum** text field, type 100.
- 3** In the **Maximum** text field, type 16000.

On-Axis Sensitivity

- 1 In the **Model Builder** window, under **Results** click **ID Plot Group 4**.
- 2 In the **Settings** window for **ID Plot Group**, type On-Axis Sensitivity in the **Label** text field.
- 3 Click to expand the **Title** section. From the **Title type** list, choose **Label**.
- 4 Locate the **Plot Settings** section.
- 5 Select the **x-axis label** checkbox. In the associated text field, type Frequency (Hz).
- 6 Select the **y-axis label** checkbox. In the associated text field, type Sound Pressure Level (dB).
- 7 Click to expand the **Number Format** section. Locate the **Legend** section. From the **Position** list, choose **Lower left**.

Octave Band 1

- 1 In the **On-Axis Sensitivity** toolbar, click  **More Plots** and choose **Octave Band**.
- 2 In the **Settings** window for **Octave Band**, locate the **Data** section.
- 3 From the **Dataset** list, choose **Study: Frequency Response/Parametric Solutions 1 (sol2)**.
- 4 Locate the **y-Axis Data** section. In the **Expression** text field, type `pext(0,0,1[m])`.
- 5 Locate the **Plot** section. From the **Quantity** list, choose **Continuous power spectral density**.
- 6 Click to expand the **Coloring and Style** section. Find the **Line style** subsection. From the **Line** list, choose **None**.
- 7 Find the **Line markers** subsection. From the **Marker** list, choose **Point**.
- 8 From the **Color** list, choose **Cycle (reset)**.
- 9 Click to expand the **Legends** section. Select the **Show legends** checkbox.
- 10 From the **Legends** list, choose **Manual**.
- 11 In the table, enter the following settings:

Legends
Titanium
Composite Material 1
Composite Material 2

Function 1

- 1 In the **Model Builder** window, click **Function 1**.
- 2 In the **Settings** window for **Function**, click to expand the **Legends** section.

3 In the table, enter the following settings:

Legends

Titanium, Resolved

Function 2

- 1 In the **Model Builder** window, click **Function 2**.
- 2 In the **Settings** window for **Function**, locate the **Legends** section.
- 3 In the table, enter the following settings:

Legends

Composite Material 1, Resolved

Function 3

- 1 In the **Model Builder** window, click **Function 3**.
- 2 In the **Settings** window for **Function**, locate the **Legends** section.
- 3 In the table, enter the following settings:

Legends

Composite Material 2, Resolved

On-Axis Sensitivity

- 1 In the **Model Builder** window, click **On-Axis Sensitivity**.
- 2 In the **On-Axis Sensitivity** toolbar, click  **Plot**.

Electric Input Impedance

- 1 In the **Model Builder** window, under **Results** click **ID Plot Group 5**.
- 2 In the **Settings** window for **ID Plot Group**, type Electric Input Impedance in the **Label** text field.
- 3 Locate the **Title** section. From the **Title type** list, choose **Label**.
- 4 Locate the **Plot Settings** section.
- 5 Select the **x-axis label** checkbox. In the associated text field, type Frequency (Hz).
- 6 Select the **y-axis label** checkbox. In the associated text field, type Electric Impedance ([Omega]).

Global 1

- 1 Right-click **Electric Input Impedance** and choose **Global**.
- 2 In the **Settings** window for **Global**, locate the **Data** section.

3 From the **Dataset** list, choose **Study: Frequency Response/Parametric Solutions I (sol2)**.

4 Locate the **y-Axis Data** section. In the table, enter the following settings:

Expression	Unit	Description
$\text{abs}(\text{cir.V1.v}/\text{cir.V1.i})$	Ω	abs(Z)

5 Locate the **x-Axis Data** section. From the **Axis source data** list, choose **freq**.

6 Click to expand the **Coloring and Style** section. Find the **Line style** subsection. From the **Line** list, choose **None**.

7 Find the **Line markers** subsection. From the **Marker** list, choose **Point**.

8 From the **Color** list, choose **Cycle (reset)**.

9 Click to expand the **Legends** section. From the **Legends** list, choose **Manual**.

10 In the table, enter the following settings:

Legends
Titanium
Composite Material 1
Composite Material 2

Function 1

1 In the **Model Builder** window, click **Function 1**.

2 In the **Settings** window for **Function**, locate the **Legends** section.

3 In the table, enter the following settings:

Legends
Titanium, Resolved

Function 2

1 In the **Model Builder** window, click **Function 2**.

2 In the **Settings** window for **Function**, locate the **Legends** section.

3 In the table, enter the following settings:

Legends
Composite Material 1, Resolved

Function 3

1 In the **Model Builder** window, click **Function 3**.

2 In the **Settings** window for **Function**, locate the **Legends** section.

3 In the table, enter the following settings:

Legends

Composite Material 2, Resolved

Electric Input Impedance

- 1 In the **Model Builder** window, click **Electric Input Impedance**.
- 2 In the **Electric Input Impedance** toolbar, click  **Plot**.

Spatial Sensitivity, Titanium

- 1 In the **Results** toolbar, click  **Polar Plot Group**.
- 2 In the **Settings** window for **Polar Plot Group**, type Spatial Sensitivity, Titanium in the **Label** text field.
- 3 Locate the **Data** section. From the **Dataset** list, choose **Study: Frequency Response/ Parametric Solutions 1 (sol2)**.
- 4 From the **Material Switch 1** list, choose **From list**.
- 5 In the **Values (Material Switch 1)** list box, select **Layered Material: Titanium**.
- 6 From the **Parameter selection (freq)** list, choose **From list**.
- 7 In the **Parameter values (freq (Hz))** list box, select **10000**.
- 8 Click to expand the **Title** section. From the **Title type** list, choose **Label**.
- 9 Locate the **Axis** section. From the **Zero angle** list, choose **Up**.
- 10 From the **Rotation direction** list, choose **Clockwise**.

Radiation Pattern 1

- 1 In the **Spatial Sensitivity, Titanium** toolbar, click  **More Plots** and choose **Radiation Pattern**.
- 2 In the **Settings** window for **Radiation Pattern**, locate the **Evaluation** section.
- 3 Find the **Angles** subsection. In the **Number of angles** text field, type 180.
- 4 From the **Restriction** list, choose **Manual**.
- 5 In the ϕ **start** text field, type -90.
- 6 In the ϕ **range** text field, type 180.
- 7 Find the **Normal vector** subsection. In the **y** text field, type 1.
- 8 In the **z** text field, type 0.
- 9 Find the **Evaluation distance** subsection. In the **Radius** text field, type 1000.
- 10 Find the **Reference direction** subsection. In the **x** text field, type 0.

11 In the **z** text field, type 1.

12 Click to expand the **Legends** section. Select the **Show legends** checkbox.

13 From the **Legends** list, choose **Manual**.

14 In the table, enter the following settings:

Legends
freq=10000 Hz

Spatial Sensitivity, Titanium

1 In the **Model Builder** window, click **Spatial Sensitivity, Titanium**.

2 In the **Spatial Sensitivity, Titanium** toolbar, click  **Plot**.

Spatial Sensitivity, Composite Material 1

1 Right-click **Spatial Sensitivity, Titanium** and choose **Duplicate**.

2 In the **Settings** window for **Polar Plot Group**, type Spatial Sensitivity, Composite Material 1 in the **Label** text field.

3 Locate the **Data** section. In the **Values (Material Switch 1)** list box, select **Layered Material: Composite Material 1**.

4 In the **Spatial Sensitivity, Composite Material 1** toolbar, click  **Plot**.

Spatial Sensitivity, Composite Material 2

1 Right-click **Spatial Sensitivity, Composite Material 1** and choose **Duplicate**.

2 In the **Settings** window for **Polar Plot Group**, type Spatial Sensitivity, Composite Material 2 in the **Label** text field.

3 Locate the **Data** section. In the **Values (Material Switch 1)** list box, select **Layered Material: Composite Material 2**.

4 In the **Spatial Sensitivity, Composite Material 2** toolbar, click  **Plot**.

Directivity Plot

1 In the **Results** toolbar, click  **ID Plot Group**.

2 In the **Settings** window for **ID Plot Group**, type Directivity Plot in the **Label** text field.

3 Locate the **Data** section. From the **Dataset** list, choose **Study: Frequency Response/ Parametric Solutions 1 (sol2)**.

4 From the **Material Switch 1** list, choose **From list**.

5 In the **Values (Material Switch 1)** list box, select **Layered Material: Composite Material 2**.

6 Locate the **Plot Settings** section. Select the **y-axis label** checkbox.

- 7 Select the **x-axis label** checkbox. In the associated text field, type Frequency (Hz).
- 8 In the **y-axis label** text field, type Angle (deg).

Directivity I

- 1 In the **Directivity Plot** toolbar, click  **More Plots** and choose **Directivity**.
- 2 In the **Settings** window for **Directivity**, locate the **Evaluation** section.
- 3 Find the **Angles** subsection. In the **Number of angles** text field, type 180.
- 4 From the **Restriction** list, choose **Manual**.
- 5 In the ϕ **start** text field, type -90.
- 6 In the ϕ **range** text field, type 180.
- 7 Find the **Normal vector** subsection. In the **y** text field, type 1.
- 8 In the **z** text field, type 0.
- 9 Find the **Evaluation distance** subsection. In the **Radius** text field, type 1000.
- 10 Find the **Reference direction** subsection. In the **x** text field, type 0.
- 11 In the **z** text field, type 1.

Directivity Plot

- 1 In the **Model Builder** window, click **Directivity Plot**.
- 2 In the **Directivity Plot** toolbar, click  **Plot**.