



Model created in COMSOL Multiphysics 6.4

Aluminum Nitride Lamb Wave Resonator — Layered Shell Version

Introduction

This tutorial demonstrates how to model an aluminum nitride Lamb wave resonator using the Electric Currents in Layered Shells interface in combination with the Layered Shell interface. The Lamb wave resonator (LWR) is an important building block in circuits used in mobile communication systems. Its operational characteristics are controlled by the piezoelectric material properties, the pattern of thin conducting layer on its surface, and its dimensions. Using the Piezoelectricity, Layered Shell multiphysics interface and materials from the Piezoelectric Material Library, you can create a digital prototype of an LWR.

This model is a layered shell version of *Aluminum Nitride Lamb Wave Resonator — 3D* from the MEMS Module Application Library and requires the MEMS Module, Structural Mechanics Module, and Composite Materials Module.



Read more about the Composite Materials Module and piezoelectricity modeling in the following COMSOL blogs:

- [Introduction to the Composite Materials Module.](#)
 - [Modeling Piezoelectricity: Which Module to Use?](#)
-

Model Definition

In this tutorial, the LWR is an aluminum nitride (piezoelectric) block with an interdigitated electrode (IDE) on its surface, as shown in [Figure 1](#). The base geometry used to set up the layered physics interfaces is shown in [Figure 2](#). Suspended from four anchor points, the $0.4\ \mu\text{m}$ piezoelectric block responds to AC excitation through the platinum IDE (80 nm). The LWR is designed to resonate at 7.9809 GHz.

The LWR geometric parameters are summarized in the first table in the [Modeling Instructions](#) section so the geometry can easily be modified for design optimization. The geometry is rebuilt automatically when geometric parameters are changed if the rules are followed. For example, n must be chosen so that $(n+1)/4$ is an integer, or $n = \{3, 7, 11, \dots\}$. Also, the overlap parameter op should be smaller than the length of the finger l , that is, $op < l$. Keep in mind, however, that changes in the geometry will shift the resonant frequency. An outline of the steps in the fabrication of an actual LWR can be found in [Ref. 1](#).

In this model, the fully coupled structural and electrostatic equations are solved in the piezoelectric and conducting domain. The model also includes mechanical loss through an isotropic structural loss factor of 0.002 for the piezoelectric and the platinum layers.

In this tutorial we are interested in the symmetric S0 mode, which, in typical applications, results in maximal electromechanical coupling efficiency. Because of the symmetry of the device structure and the symmetry of the S0 mode, only one half of the device needs to be modeled. This reduces computational time, which is important because this model requires a fine mesh to compute accurate eigenmodes.

This tutorial shows the setup of Eigenfrequency and Frequency Domain studies. In the Eigenfrequency study you investigate the eigenmodes of the structure to find the S0 mode. In the subsequent Frequency Domain study, a 1 V drive signal is applied to the signal electrode and the resonator's frequency response from 7.95 to 8.05 GHz is analyzed.

The results of this example is compared with the solid model variant *Aluminum Nitride Lamb Wave Resonator — 3D*. To match the results, the model setup needs to be the same. In the solid version of the example, the thin Platinum layer is not modeled explicitly in the **Electrostatic** interface, rather this thin layer modeled as a layer with either constant voltage or zero voltage using the **Terminal** and **Ground** features. In the current example, the thin layer is considered as a conducting layer with uniform or zero voltage across all interfaces using the similar boundary conditions.

In the solid version of example, the **Solid Mechanics** interface has quadratic Serendipity discretization with three mesh elements across the thickness of the piezoelectric layer, and linear discretization with single mesh element across the conducting layer (through **Thin Layer** feature). While the **Electrostatic** interface has quadratic Lagrange discretization. In this example, the quadratic-linear discretization is chosen for the **Layered Shell** interface, and quadratic discretization for the **Electric Currents in Layered Shells** interface. Three mesh elements are used in the piezoelectric layer, while only one mesh element is used in the conducting layer. This is specified using the settings of **Layered Material** nodes.

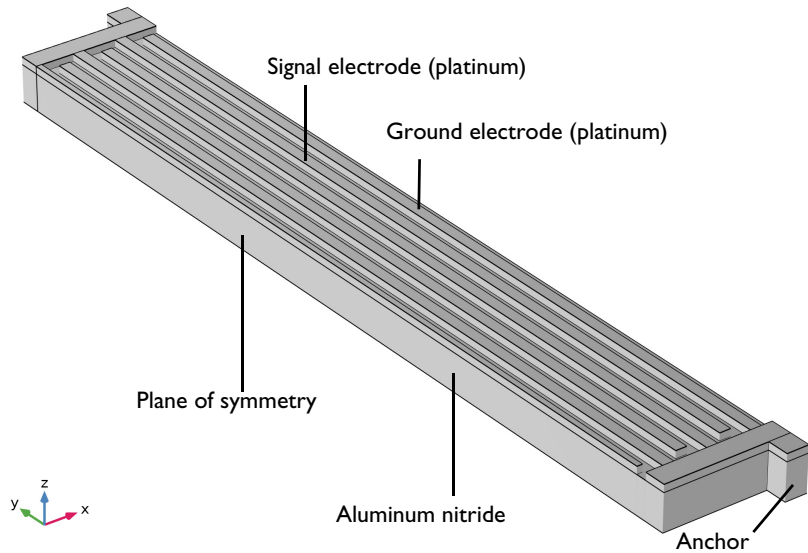

Figure 1: The 3D geometry of one half of the Lamb wave resonator.

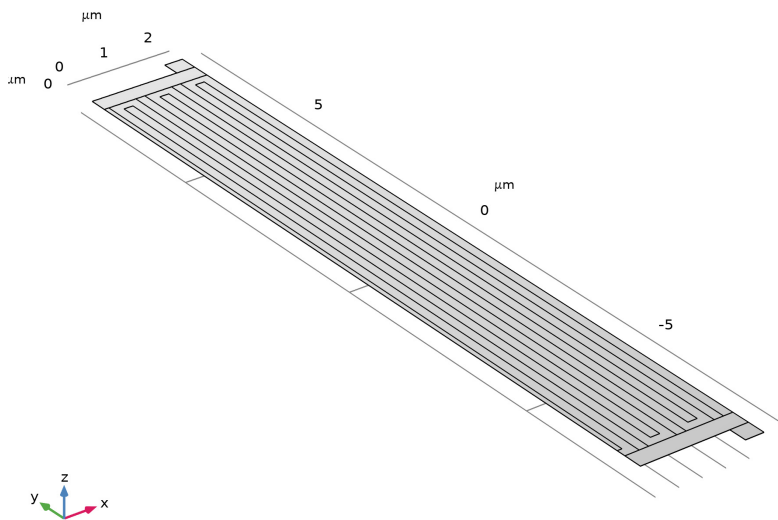

Figure 2: The layered shell version of the model geometry.

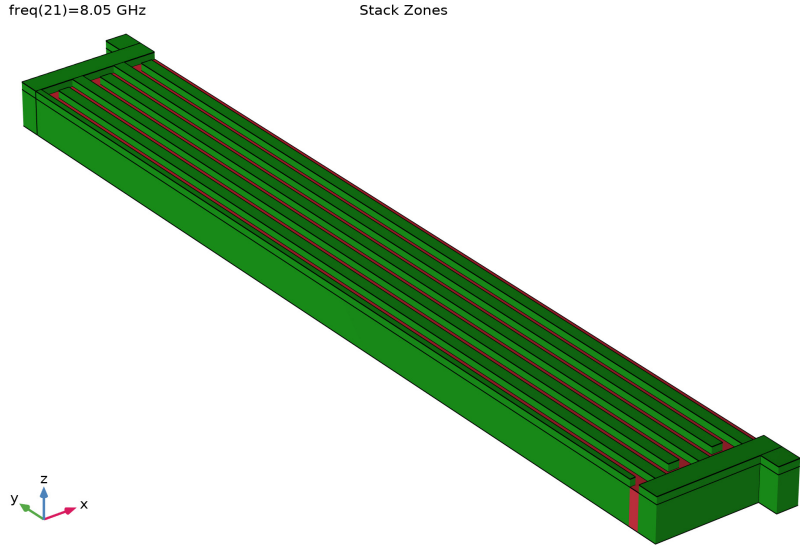

Figure 3: Zones with different layers in the layered shell geometry. The red zone has only aluminum nitride, the green zone has aluminum nitride and platinum layers.

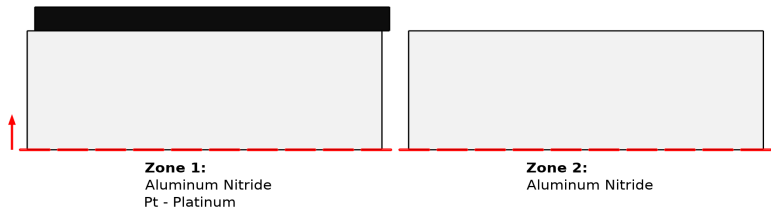

Figure 4: Cross-sectional view of zones having layers of different material and thickness.

Results and Discussion

Figure 5 shows the displacement in the z direction for the S_0 mode at 7.9809 GHz. In high-frequency resonant devices such as LWRs, the Eigenfrequency study returns many extraneous solutions very close to the mode of interest. Only through visual inspection, one can distinguish the correct mode from the spurious modes. Figure 6 shows the solid displacement across the XZ cut plane through the center of the resonator to verify the S_0 mode.

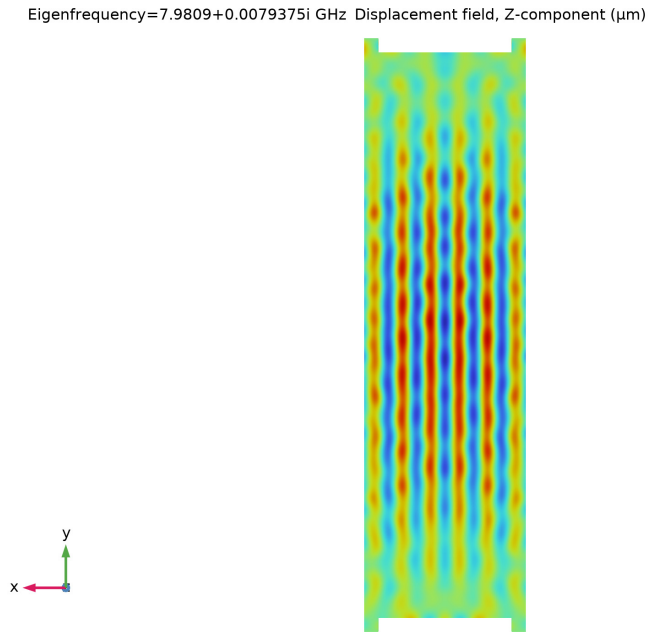

Figure 5: Displacement along the z -axis for the S_0 mode at 7.7506 GHz.

Eigenfrequency=7.9809+0.0079375i GHz Displacement magnitude (μm)



Figure 6: Solid displacement across the XZ cut plane through the center of the resonator for the S0 mode at 7.9809 GHz.

Figure 7 shows a log plot of the admittance magnitude versus frequency from 7.95 to 8.05 GHz. The plot is annotated with the positions of resonance and anti-resonance peaks for the calculation of the electromechanical coupling coefficient.

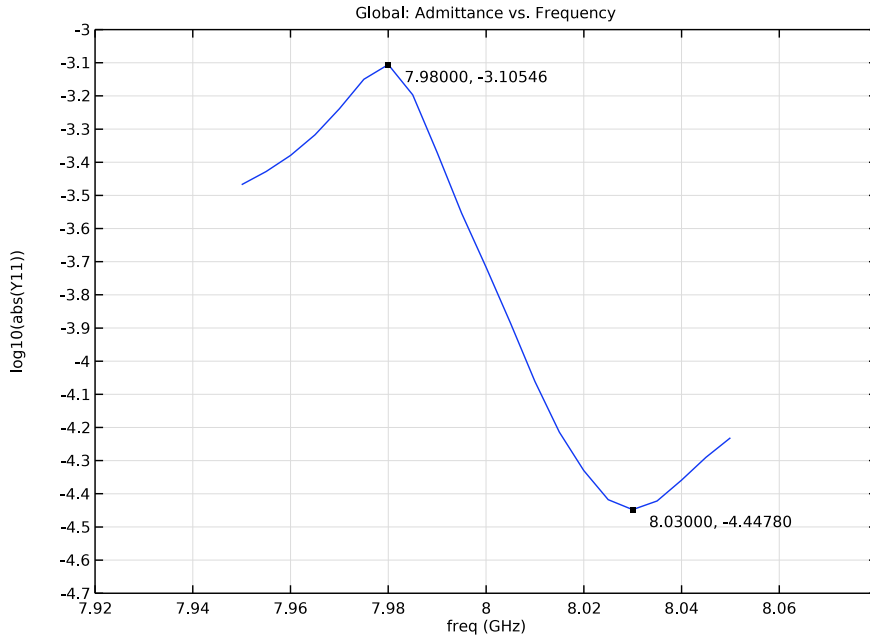

Figure 7: Admittance versus frequency.

The frequency response yields important information relating to the device performance such as the effective electromechanical coupling coefficient given by

$$k_t^2 = \frac{\pi^2}{4} \times \frac{f_s(f_p - f_s)}{f_p^2}$$

where f_s and f_p are the resonance and anti-resonance frequencies, respectively, with $f_s = 7.98$, $f_p = 8.03$, and $k_t^2 = 1.526\%$. The effective electromechanical coupling coefficient is known to be a measure of the transduction efficiency for conversion of electrical into mechanical energy.

Notes About the COMSOL Implementation

- Modeling a composite laminated shell requires a 2D surface geometry, called a base surface, and a **Layered Material** node that adds an extra dimension (1D) to the base surface geometry in the surface normal direction. Using the **Layered Material** functionality, you can model several layers of different thicknesses, material properties,

and fiber orientations. You can optionally specify the interface materials between the layers and the control mesh elements in each layer.

- The **Layered Material Stack** node is used to define various zones/sections of the Lamb wave resonator.
- The third direction for the selected coordinate system in the **Single Layer Material**, **Layered Material Link**, or **Layered Material Stack** represents the normal direction of the **Layered Shell** or **Shell** physics. This is also the direction in which the layer stacking is interpreted from bottom to top, and therefore, it is crucial to know it during modeling. There are two ways to achieve this:
 - Using physics symbols: Go to the physics settings, find the **Physics Symbols** section, and select the **Enable physics symbols** checkbox. Then go to the material feature, for instance, **Linear Elastic Material**, to see the normal direction represented by green arrows in the geometry.
 - Using result templates: When a solution dataset is available, use the result template **Thickness and Orientation** to plot the normal direction.

Reference

I. J. Zou, C.M. Lin, A. Gao, and A.P. Pisano, “The Multi-Mode Resonance in AlN Lamb Wave Resonators,” *J. Microelectromech. Syst.*, vol. 27, no. 6, pp. 973–84, 2018.

Application Library path: Composite_Materials_Module/Multiphysics/
aln_lamb_wave_resonator_layered

Modeling Instructions

From the **File** menu, choose **New**.



NEW

In the **New** window, click  **Model Wizard**.

MODEL WIZARD

1 In the **Model Wizard** window, click  **3D**.

Start by creating a new 3D model with a **Piezoelectricity, Layered Shell** multiphysics interface.

- 2 In the **Select Physics** tree, select **Structural Mechanics > Electromagnetics–Structure Interaction > Piezoelectricity > Piezoelectricity, Layered Shell**.
- 3 Click **Add**.
- 4 Click  **Study**.
- 5 In the **Select Study** tree, select **Preset Studies for Selected Multiphysics > Eigenfrequency**.
- 6 Click  **Done**.

GEOMETRY I

Use microns as the geometry unit.

- 1 In the **Model Builder** window, under **Component I (comp1)** click **Geometry I**.
- 2 In the **Settings** window for **Geometry**, locate the **Units** section.
- 3 From the **Length unit** list, choose **μm**.

Define and specify the parameters of the model.

GLOBAL DEFINITIONS

Parameters I



- 1 In the **Model Builder** window, under **Global Definitions** click **Parameters I**.
- 2 In the **Settings** window for **Parameters**, locate the **Parameters** section.
- 3 In the table, enter the following settings:

| Name | Expression | Value | Description |
|------|------------|-----------|--|
| tp | 0.4[um] | 4E-7 m | Thickness of piezoelectric layer |
| l | 15[um] | 1.5E-5 m | Length of finger |
| wf | 0.2[um] | 2E-7 m | Width of finger |
| op | 14.6[um] | 1.46E-5 m | Length of overlap, for op less than l |
| dy | (1-op)/2 | 2E-7 m | Electrode separation |
| n | 11 | 11 | Number of fingers, where (n+1)/4 = integer |
| we | 0.2[um] | 2E-7 m | Width of edge |
| la | 0.4[um] | 4E-7 m | Length of anchor |
| Vapp | 1[V] | 1 V | Applied voltage |
| eta0 | 2.0e-3 | 0.002 | Loss factor for electrode layer |

| Name | Expression | Value | Description |
|------|------------|--------|-------------------------------------|
| eta1 | 2.0e-3 | 0.002 | Loss factor for piezoelectric layer |
| te | 80[nm] | 8E-8 m | Thickness of electrode layer |

Add material models and layered materials under **Global Definitions** node.

ADD MATERIAL

- 1 In the **Materials** toolbar, click  **Add Material** to open the **Add Material** window.
- 2 Go to the **Add Material** window.
- 3 In the tree, select **MEMS > Metals > Pt - Platinum**.
- 4 Click the **Add to Global Materials** button in the window toolbar.
- 5 In the tree, select **Piezoelectric > Aluminum Nitride**.
- 6 Click the **Add to Global Materials** button in the window toolbar.
- 7 In the **Materials** toolbar, click  **Add Material** to close the **Add Material** window.

GLOBAL DEFINITIONS

Pt - Platinum (mat1)

- 1 In the **Model Builder** window, under **Global Definitions > Materials** click **Pt - Platinum (mat1)**.
- 2 In the **Settings** window for **Material**, click to expand the **Material Properties** section.
- 3 In the **Material properties** tree, select **Basic Properties > Isotropic Structural Loss Factor**.
- 4 Click  **Add to Material**.
- 5 Locate the **Material Contents** section. In the table, enter the following settings:

| Property | Variable | Value | Unit | Property group |
|----------------------------------|----------|-------|------|----------------|
| Isotropic structural loss factor | eta_s | eta0 | l | Basic |

- 6 Locate the **Material Properties** section. In the **Material properties** tree, select **Basic Properties > Relative Permittivity**.
- 7 Click  **Add to Material**.

8 Locate the **Material Contents** section. In the table, enter the following settings:

| Property | Variable | Value | Unit | Property group |
|-----------------------|---|-------|------|----------------|
| Relative permittivity | epsilon _{r_} iso ; epsilon _{r_} ii = epsilon _{r_} iso, epsilon _{r_} ij = 0 | 1 | | Basic |

Layered Material: Platinum

- 1 In the **Model Builder** window, right-click **Materials** and choose **Layered Material**.
- 2 In the **Settings** window for **Layered Material**, type Layered Material: Platinum in the **Label** text field.
- 3 Locate the **Layer Definition** section. In the table, enter the following settings:

| Layer | Material | Rotation | Value | Thickness | Mesh elements |
|---------|----------------------|----------|-------|-----------|---------------|
| Layer 1 | Pt - Platinum (mat1) | 0.0 | 0 rad | te | 1 |

Layered Material: Aluminum Nitride

- 1 Right-click **Materials** and choose **Layered Material**.
- 2 In the **Settings** window for **Layered Material**, type Layered Material: Aluminum Nitride in the **Label** text field.
- 3 Locate the **Layer Definition** section. In the table, enter the following settings:

| Layer | Material | Rotation | Value | Thickness | Mesh elements |
|---------|-------------------------|----------|-------|-----------|---------------|
| Layer 1 | Aluminum Nitride (mat2) | 0.0 | 0 rad | tp | 3 |

Aluminum Nitride (mat2)

- 1 In the **Model Builder** window, click **Aluminum Nitride (mat2)**.
- 2 In the **Settings** window for **Material**, locate the **Material Properties** section.
- 3 In the **Material properties** tree, select **Basic Properties > Isotropic Structural Loss Factor**.
- 4 Click **+ Add to Material**.

5 Locate the **Material Contents** section. In the table, enter the following settings:

| Property | Variable | Value | Unit | Property group |
|----------------------------------|----------|-------|------|----------------|
| Isotropic structural loss factor | eta_s | eta1 | | Basic |

Create the geometry model for half part of the lamb wave resonator.

GEOMETRY I

Work Plane 1 (wp1)

- 1 In the **Model Builder** window, expand the **Component 1 (comp1) > Geometry 1** node.
- 2 Right-click **Geometry 1** and choose **Work Plane**.



Work Plane 1 (wp1) > Rectangle 1 (r1)

- 1 In the **Work Plane** toolbar, click  **Rectangle**.
- 2 In the **Settings** window for **Rectangle**, locate the **Size and Shape** section.
- 3 In the **Width** text field, type wf.
- 4 In the **Height** text field, type 1.
- 5 Locate the **Position** section. From the **Base** list, choose **Center**.
- 6 In the **yw** text field, type dy/2.

Work Plane 1 (wp1) > Array 1 (arr1)

- 1 In the **Work Plane** toolbar, click  **Transforms** and choose **Array**.
- 2 Select the object **r1** only.
- 3 In the **Settings** window for **Array**, locate the **Size** section.
- 4 In the **xw size** text field, type (n+1)/4.
- 5 Locate the **Displacement** section. In the **xw** text field, type 4*wf.

Work Plane 1 (wp1) > Move 1 (mov1)

- 1 In the **Work Plane** toolbar, click  **Transforms** and choose **Move**.
- 2 Click the  **Select All** button in the **Graphics** toolbar.
- 3 In the **Settings** window for **Move**, locate the **Input** section.
- 4 Select the **Keep input objects** checkbox.
- 5 Locate the **Displacement** section. In the **xw** text field, type 2*wf.
- 6 In the **yw** text field, type -dy.

Work Plane 1 (wp1) > Rectangle 2 (r2)

- 1 In the **Work Plane** toolbar, click  **Rectangle**.
- 2 In the **Settings** window for **Rectangle**, locate the **Size and Shape** section.
- 3 In the **Width** text field, type $(n-1/2)*wf+we$.
- 4 In the **Height** text field, type $2*wf$.
- 5 Locate the **Position** section. In the **yw** text field, type $(1+dy)/2$.

Work Plane 1 (wp1) > Rectangle 3 (r3)

- 1 In the **Work Plane** toolbar, click  **Rectangle**.
- 2 In the **Settings** window for **Rectangle**, locate the **Size and Shape** section.
- 3 In the **Width** text field, type $2*we$.
- 4 In the **Height** text field, type $1a$.
- 5 Locate the **Position** section. In the **xw** text field, type $(n-1/2)*wf-we$.
- 6 In the **yw** text field, type $(1+dy)/2+2*wf$.

Work Plane 1 (wp1) > Mirror 1 (mir1)

- 1 In the **Work Plane** toolbar, click  **Transforms** and choose **Mirror**.
- 2 Select the objects **r2** and **r3** only.
- 3 In the **Settings** window for **Mirror**, locate the **Input** section.
- 4 Select the **Keep input objects** checkbox.
- 5 Locate the **Normal Vector to Line of Reflection** section. In the **xw** text field, type 0.
- 6 In the **yw** text field, type -1.

Work Plane 1 (wp1) > Rectangle 4 (r4)



- 1 In the **Work Plane** toolbar, click  **Rectangle**.
- 2 In the **Settings** window for **Rectangle**, locate the **Size and Shape** section.
- 3 In the **Width** text field, type $(n+1/2)*wf$.
- 4 In the **Height** text field, type $1+dy$.
- 5 Locate the **Position** section. From the **Base** list, choose **Center**.
- 6 In the **xw** text field, type $(n+1/2)*wf/2$.

Work Plane 1 (wp1) > Partition Objects 1 (par1)

- 1 In the **Work Plane** toolbar, click  **Booleans and Partitions** and choose **Partition Objects**.
- 2 Select the object **arr1(1,1)** only.

- 3 In the **Settings** window for **Partition Objects**, locate the **Partition Objects** section.
- 4 Click to select the  **Activate Selection** toggle button for **Tool objects**.
- 5 Select the object **r4** only.
- 6 Select the **Keep tool objects** checkbox.

Work Plane 1 (wp1) > Delete Entities 1 (dell)

- 1 In the **Model Builder** window, right-click **Plane Geometry** and choose **Delete Entities**.
- 2 In the **Settings** window for **Delete Entities**, locate the **Entities or Objects to Delete** section.
- 3 From the **Geometric entity level** list, choose **Domain**.
- 4 On the object **par1**, select Domain 1 only.
- 5 Click  **Build Selected**.
- 6 In the **Model Builder** window, right-click **Geometry 1** and choose **Build All**.
- 7 Click the  **Zoom Extents** button in the **Graphics** toolbar.

Define selections for the electrodes and other boundaries. This will make specifying the material models and physics interface settings easier.

DEFINITIONS



Signal

- 1 In the **Model Builder** window, expand the **Component 1 (comp1) > Definitions** node.
- 2 Right-click **Definitions** and choose **Selections > Box**.
- 3 In the **Settings** window for **Box**, type **Signal** in the **Label** text field.
- 4 Locate the **Geometric Entity Level** section. From the **Level** list, choose **Boundary**.
- 5 Locate the **Box Limits** section. In the **y minimum** text field, type $-1/2$.
- 6 In the **z minimum** text field, type 0 .
- 7 Locate the **Output Entities** section. From the **Include entity if** list, choose **Entity inside box**.

Ground

- 1 Right-click **Signal** and choose **Duplicate**.
- 2 In the **Settings** window for **Box**, type **Ground** in the **Label** text field.
- 3 Locate the **Box Limits** section. In the **y minimum** text field, type $-\text{Inf}$.
- 4 In the **y maximum** text field, type $1/2$.

Electrodes

- 1 In the **Definitions** toolbar, click  **Union**.
- 2 In the **Settings** window for **Union**, type Electrodes in the **Label** text field.
- 3 Locate the **Geometric Entity Level** section. From the **Level** list, choose **Boundary**.
- 4 Locate the **Input Entities** section. Under **Selections to add**, click  **Add**.
- 5 In the **Add** dialog, in the **Selections to add** list, choose **Signal** and **Ground**.
- 6 Click **OK**.

Symmetry

- 1 In the **Definitions** toolbar, click  **Box**.
- 2 In the **Settings** window for **Box**, type Symmetry in the **Label** text field.
- 3 Locate the **Geometric Entity Level** section. From the **Level** list, choose **Edge**.
- 4 Locate the **Box Limits** section. In the **x maximum** text field, type 0.
- 5 Locate the **Output Entities** section. From the **Include entity if** list, choose **Entity inside box**.

Base Surface

- 1 In the **Definitions** toolbar, click  **Box**.
- 2 In the **Settings** window for **Box**, type Base Surface in the **Label** text field.
- 3 Locate the **Geometric Entity Level** section. From the **Level** list, choose **Boundary**.
- 4 Locate the **Box Limits** section. In the **z minimum** text field, type 0.
- 5 Locate the **Output Entities** section. From the **Include entity if** list, choose **Entity inside box**.

Device

- 1 In the **Definitions** toolbar, click  **Box**.
- 2 In the **Settings** window for **Box**, type Device in the **Label** text field.
- 3 Locate the **Geometric Entity Level** section. From the **Level** list, choose **Boundary**.
- 4 Locate the **Box Limits** section. In the **y minimum** text field, type $-((1+dy)/2+2*wf+1a)+0.01$.
- 5 In the **y maximum** text field, type $(1+dy)/2+2*wf+1a-0.01$.

Fixed Constraints

- 1 In the **Definitions** toolbar, click  **Explicit**.
- 2 In the **Settings** window for **Explicit**, type Fixed Constraints in the **Label** text field.
- 3 Locate the **Input Entities** section. From the **Geometric entity level** list, choose **Edge**.

- 4 Click  **Paste Selection**.
- 5 In the **Paste Selection** dialog, type 33 40 in the **Selection** text field.
- 6 Click **OK**.

The stacking of the Platinum layer is not the same across the Aluminum Nitride base. In order to model the stacking, add a **Layered Material Stack** node with **Layered Material Link** subnodes having different selections.

MATERIALS

Layered Material Stack 1 (stlmat1)

- 1 In the **Model Builder** window, under **Component 1 (comp1)** right-click **Materials** and choose **Layers > Layered Material Stack**.
- 2 In the **Settings** window for **Layered Material Stack**, locate the **Orientation and Position** section.
- 3 From the **Position** list, choose **Bottom side on boundary**.

Aluminum Nitride

- 1 In the **Model Builder** window, under **Component 1 (comp1) > Materials > Layered Material Stack 1 (stlmat1)** click **Layered Material Link 1 (stlmat1.stlmat1)**.
- 2 In the **Settings** window for **Layered Material Link**, type Aluminum Nitride in the **Label** text field.
- 3 Locate the **Link Settings** section. From the **Material** list, choose **Layered Material: Aluminum Nitride (lmat2)**.

Pt - Platinum

- 1 In the **Model Builder** window, right-click **Layered Material Stack 1 (stlmat1)** and choose **Layered Material Link**.
- 2 In the **Settings** window for **Layered Material Link**, type Pt - Platinum in the **Label** text field.
- 3 Locate the **Boundary Selection** section. From the **Selection** list, choose **Electrodes**.

To visualize the stacking, create a **Layer Cross Section Preview** plot through an action button in the **Layered Material Settings** section.

Layered Material Stack 1 (stlmat1)

- 1 In the **Model Builder** window, click **Layered Material Stack 1 (stlmat1)**.

- 2 In the **Settings** window for **Layered Material Stack**, click **Layer Cross-Section Preview** in the upper-right corner of the **Layered Material Settings** section. From the menu, choose **Create Layer Cross-Section Plot**.

RESULTS

Layer Cross-Section Preview

- 1 In the **Model Builder** window, expand the **Results** node, then click **Layer Cross-Section Preview**.
- 2 In the **Layer Cross-Section Preview** toolbar, click  **Plot**.

Specify the settings for the **Layered Shell** interface.

LAYERED SHELL (LSHELL)

Linear Elastic Material 1

In the **Model Builder** window, under **Component 1 (comp1) > Layered Shell (lshell)** click **Linear Elastic Material 1**.

Damping 1

- 1 In the **Physics** toolbar, click  **Attributes** and choose **Damping**.
- 2 In the **Settings** window for **Damping**, locate the **Damping Settings** section.
- 3 From the **Damping type** list, choose **Isotropic loss factor**.

Piezoelectric Material 1

- 1 In the **Model Builder** window, under **Component 1 (comp1) > Layered Shell (lshell)** click **Piezoelectric Material 1**.
- 2 In the **Settings** window for **Piezoelectric Material**, locate the **Shell Properties** section.
- 3 Clear the **Use all layers** checkbox.
- 4 In the **Selection** table, clear the checkbox for **Layer 1 - Pt - Platinum**.

Mechanical Damping 1

- 1 In the **Physics** toolbar, click  **Attributes** and choose **Mechanical Damping**.
- 2 In the **Settings** window for **Mechanical Damping**, locate the **Damping Settings** section.
- 3 From the **Damping type** list, choose **Isotropic loss factor**.

Fixed Constraint 1

- 1 In the **Physics** toolbar, click  **Edges** and choose **Fixed Constraint**.
- 2 In the **Settings** window for **Fixed Constraint**, locate the **Edge Selection** section.
- 3 From the **Selection** list, choose **Fixed Constraints**.

Symmetry 1

- 1 In the **Physics** toolbar, click  **Edges** and choose **Symmetry**.
- 2 In the **Settings** window for **Symmetry**, locate the **Edge Selection** section.
- 3 From the **Selection** list, choose **Symmetry**.

Continuity 1

- 1 In the **Physics** toolbar, click  **Edges** and choose **Continuity**.
- 2 In the **Settings** window for **Continuity**, locate the **Layer Selection** section.
- 3 From the **Source** list, choose **Layered Material Stack 1 (stlmat1.zone1)**.
- 4 From the **Destination** list, choose **Layered Material Stack 1 (stlmat1.zone2)**.
- 5 In the **Model Builder** window, click **Layered Shell (lshell)**.
- 6 In the **Settings** window for **Layered Shell**, click to expand the **Discretization** section.
- 7 From the **Displacement field** list, choose **Quadratic-linear serendipity**.

Specify the settings for the **Electric Currents in Layered Shells** interface.

ELECTRIC CURRENTS IN LAYERED SHELLS (ECIS)

Conductive Shell 1

In the **Model Builder** window, under **Component 1 (comp1) > Electric Currents in Layered Shells (ecis)** click **Conductive Shell 1**.

Ground 1

- 1 In the **Physics** toolbar, click  **Boundaries** and choose **Ground**.
- 2 In the **Settings** window for **Ground**, locate the **Boundary Selection** section.
- 3 From the **Selection** list, choose **Ground**.
- 4 Locate the **Interface Selection** section. From the **Apply to** list, choose **All interfaces**.

Conductive Shell 1

In the **Model Builder** window, click **Conductive Shell 1**.

Interface Terminal 1

- 1 In the **Physics** toolbar, click  **Attributes** and choose **Interface Terminal**.
- 2 In the **Settings** window for **Interface Terminal**, locate the **Boundary Selection** section.
- 3 From the **Selection** list, choose **Signal**.
- 4 Locate the **Interface Selection** section. From the **Apply to** list, choose **All interfaces**.
- 5 Locate the **Terminal** section. From the **Terminal type** list, choose **Voltage**.
- 6 In the V_0 text field, type V_{app} .

Piezoelectric Layer 1

- 1 In the **Model Builder** window, under **Component 1 (comp1) > Electric Currents in Layered Shells (ecis)** click **Piezoelectric Layer 1**.
- 2 In the **Settings** window for **Piezoelectric Layer**, locate the **Shell Properties** section.
- 3 Clear the **Use all layers** checkbox.
- 4 In the **Selection** table, clear the checkbox for **Layer 1 - Pt - Platinum**.

Electric Continuity 1

- 1 In the **Physics** toolbar, click  **Edges** and choose **Electric Continuity**.
- 2 In the **Settings** window for **Electric Continuity**, locate the **Layer Selection** section.
- 3 From the **Source** list, choose **Layered Material Stack 1 (stlmat1)**.
- 4 From the **Destination** list, choose **Layered Material Stack 1 (stlmat1.zone2)**.
- 5 From the **Source** list, choose **Layered Material Stack 1 (stlmat1.zone1)**.
- 6 In the **Selection** table, enter the following settings:

| | Layered material | Offset (m) |
|---|-------------------------|-------------------|
| √ | Aluminum Nitride | 0 |

Create the mesh for the model.

MESH 1

Free Quad 1

- 1 In the **Mesh** toolbar, click  **More Generators** and choose **Free Quad**.
- 2 In the **Settings** window for **Free Quad**, locate the **Boundary Selection** section.
- 3 From the **Selection** list, choose **Base Surface**.

Size 1

- 1 Right-click **Free Quad 1** and choose **Size**.
- 2 In the **Settings** window for **Size**, locate the **Element Size** section.
- 3 Click the **Custom** button.
- 4 Locate the **Element Size Parameters** section.
- 5 Select the **Maximum element size** checkbox. In the associated text field, type 0.1.
- 6 Click  **Build Selected**.

Set up an **Eigenfrequency** study to search for an eigenfrequency around 8 GHz.



EIGENFREQUENCY

- 1 In the **Model Builder** window, click **Study 1**.
- 2 In the **Settings** window for **Study**, type Eigenfrequency in the **Label** text field.
- 3 Locate the **Study Settings** section. Clear the **Generate default plots** checkbox.

Step 1: Eigenfrequency

- 1 In the **Model Builder** window, under **Eigenfrequency** click **Step 1: Eigenfrequency**.
- 2 In the **Settings** window for **Eigenfrequency**, locate the **Study Settings** section.
- 3 Select the **Desired number of eigenfrequencies** checkbox. In the associated text field, type 20.
- 4 From the **Unit** list, choose **GHz**.
- 5 In the **Search for eigenfrequencies around shift** text field, type 8.

Solution 1 (sol1)

- 1 In the **Study** toolbar, click  **Show Default Solver**.
- 2 In the **Model Builder** window, expand the **Solution 1 (sol1)** node, then click **Eigenvalue Solver 1**.
- 3 In the **Settings** window for **Eigenvalue Solver**, locate the **Output** section.
- 4 From the **Scaling of eigenvectors** list, choose **Mass matrix**.
- 5 In the **Study** toolbar, click  **Compute**.



Add a **Layered Material** dataset and a **Mirror** dataset. This dataset will be used to plot the result of the **Eigenfrequency** study.

RESULTS

Layered Material 1

- 1 In the **Model Builder** window, expand the **Results > Datasets** node.
- 2 Right-click **Results > Datasets** and choose **More Datasets > Layered Material**.

Mirror 3D 1





- 1 In the **Results** toolbar, click  **More Datasets** and choose **Mirror 3D**.
- 2 In the **Settings** window for **Mirror 3D**, locate the **Data** section.
- 3 From the **Dataset** list, choose **Layered Material 1**.
- 4 Click  **Plot**.

With the solution from the **Eigenfrequency** study, create a 3D plot to display the shape of the eigenmode at 8 GHz. Use the **Mirror** dataset previously created.

Mode Shape

- 1 In the **Results** toolbar, click  **3D Plot Group**.
- 2 In the **Settings** window for **3D Plot Group**, type Mode Shape in the **Label** text field.
- 3 Locate the **Data** section. From the **Dataset** list, choose **Mirror 3D I**.
- 4 Locate the **Plot Settings** section. Clear the **Plot dataset edges** checkbox.
- 5 From the **View** list, choose **New view**.
- 6 Locate the **Color Legend** section. Clear the **Show legends** checkbox.

Surface 1

- 1 Right-click **Mode Shape** and choose **Surface**.
- 2 In the **Settings** window for **Surface**, locate the **Expression** section.
- 3 In the **Expression** text field, type w .
- 4 Select the **Description** checkbox.
- 5 Click to expand the **Range** section. Select the **Manual color range** checkbox.
- 6 In the **Minimum** text field, type $-1E10$.
- 7 In the **Maximum** text field, type $1E10$.
- 8 In the **Mode Shape** toolbar, click  **Plot**.
- 9 Click the  **Go to XY View** button in the **Graphics** toolbar.
- 10 Click the  **Go to XY View** button in the **Graphics** toolbar.
- 11 Click the  **Go to XY View** button in the **Graphics** toolbar.
- 12 Click the  **Show Grid** button in the **Graphics** toolbar.

With the solution from the **Eigenfrequency** study, create a **Slice** plot to display the eigenmode in the xz cut plane through the center.

Mode Shape, Center XZ Plane



- 1 In the **Results** toolbar, click  **3D Plot Group**.
- 2 In the **Settings** window for **3D Plot Group**, type Mode Shape, Center XZ Plane in the **Label** text field.
- 3 Locate the **Data** section. From the **Dataset** list, choose **Mirror 3D I**.
- 4 Locate the **Plot Settings** section. From the **View** list, choose **New view**.
- 5 Locate the **Color Legend** section. Clear the **Show legends** checkbox.

Slice 1

- 1 Right-click **Mode Shape, Center XZ Plane** and choose **Slice**.



- 2 In the **Settings** window for **Slice**, locate the **Expression** section.
- 3 Select the **Description** checkbox.
- 4 Locate the **Plane Data** section. From the **Plane** list, choose **zx-planes**.
- 5 In the **Planes** text field, type 1.
- 6 Locate the **Coloring and Style** section. From the **Color table type** list, choose **Discrete**.
- 7 In the **Number of bands** text field, type 15.

Mode Shape, Center XZ Plane

- 1 In the **Model Builder** window, click **Mode Shape, Center XZ Plane**.
- 2 In the **Settings** window for **3D Plot Group**, locate the **Plot Settings** section.
- 3 Clear the **Plot dataset edges** checkbox.
- 4 In the **Mode Shape, Center XZ Plane** toolbar, click  **Plot**.
- 5 Click the  **Go to XZ View** button in the **Graphics** toolbar.
- 6 Click the  **Show Grid** button in the **Graphics** toolbar.

Set up a **Frequency Domain** study with a range that includes the features of interest, for example, resonance and anti-resonance peaks. Disable the option to generate default plots from this study.

ADD STUDY



- 1 In the **Home** toolbar, click  **Add Study** to open the **Add Study** window.
- 2 Go to the **Add Study** window.
- 3 Find the **Studies** subsection. In the **Select Study** tree, select **Preset Studies for Selected Multiphysics > Frequency Domain**.
- 4 Click the **Add Study** button in the window toolbar.
- 5 In the **Home** toolbar, click  **Add Study** to close the **Add Study** window.

FREQUENCY DOMAIN - 7.95 TO 8.05 GHZ

- 1 In the **Settings** window for **Study**, type Frequency Domain - 7.95 to 8.05 GHz in the **Label** text field.
- 2 Locate the **Study Settings** section. Clear the **Generate default plots** checkbox.

Step 1: Frequency Domain

- 1 In the **Model Builder** window, under **Frequency Domain - 7.95 to 8.05 GHz** click **Step 1: Frequency Domain**.
- 2 In the **Settings** window for **Frequency Domain**, locate the **Study Settings** section.

- 3 From the **Frequency unit** list, choose **GHz**.
- 4 Click  **Range**.
- 5 In the **Range** dialog, type 7.95 in the **Start** text field.
- 6 In the **Step** text field, type 0.005.
- 7 In the **Stop** text field, type 8.05.
- 8 Click **Add**.
- 9 In the **Study** toolbar, click  **Compute**.

With the solution from **Frequency Domain** study, plot the admittance versus frequency and add a **Graph Marker** to return the coordinates of the maximum and minimum values.

RESULTS

Admittance vs. Frequency (Frequency Domain)

- 1 In the **Results** toolbar, click  **ID Plot Group**.
- 2 In the **Settings** window for **ID Plot Group**, type Admittance vs. Frequency (Frequency Domain) in the **Label** text field.
- 3 Locate the **Data** section. From the **Dataset** list, choose **Frequency Domain - 7.95 to 8.05 GHz/Solution 2 (sol2)**.
- 4 Click to expand the **Title** section. From the **Title type** list, choose **Manual**.
- 5 In the **Title** text area, type Global: Admittance vs. Frequency.
- 6 Locate the **Plot Settings** section.
- 7 Select the **y-axis label** checkbox. In the associated text field, type $\log_{10}(\text{abs}(Y_{11}))$.
- 8 Locate the **Axis** section. Select the **Manual axis limits** checkbox.
- 9 In the **x minimum** text field, type 7.92.
- 10 In the **x maximum** text field, type 8.08.
- 11 In the **y minimum** text field, type -4.7.
- 12 In the **y maximum** text field, type -3.0.
- 13 Locate the **Legend** section. Clear the **Show legends** checkbox.

Global 1

- 1 Right-click **Admittance vs. Frequency (Frequency Domain)** and choose **Global**.
- 2 In the **Settings** window for **Global**, locate the **y-Axis Data** section.



3 In the table, enter the following settings:

| Expression | Unit | Description |
|--|------|-------------|
| $\log_{10}(\text{abs}(\text{ecis.I0}_1/\text{ecis.V0}_1))$ | | |

Graph Marker 1



- 1 Right-click **Global 1** and choose **Graph Marker**.
- 2 In the **Settings** window for **Graph Marker**, locate the **Text Format** section.
- 3 Select the **Show x-coordinate** checkbox.
- 4 In the **Admittance vs. Frequency (Frequency Domain)** toolbar, click  **Plot**.

RESULT TEMPLATES

- 1 In the **Results** toolbar, click  **Result Templates** to open the **Result Templates** window.
- 2 Go to the **Result Templates** window.
- 3 In the tree, select **Frequency Domain - 7.95 to 8.05 GHz/Solution 2 (sol2) > Layered Shell > Geometry and Layup (Ishell) > Shell Geometry (Ishell)**.
- 4 Click the **Add Result Template** button in the window toolbar.
- 5 In the **Results** toolbar, click  **Result Templates** to close the **Result Templates** window.

RESULTS

Shell Geometry (Ishell)

- 1 Click the  **Zoom Extents** button in the **Graphics** toolbar.
- 2 Click the  **Show Grid** button in the **Graphics** toolbar.

Stack Zones

- 1 In the **Model Builder** window, right-click **Shell Geometry (Ishell)** and choose **Duplicate**.
- 2 In the **Settings** window for **3D Plot Group**, type **Stack Zones** in the **Label** text field.

Surface 1

- 1 In the **Model Builder** window, expand the **Stack Zones** node, then click **Surface 1**.
- 2 In the **Settings** window for **Surface**, locate the **Expression** section.
- 3 In the **Expression** text field, type `st1mat1.zone`.
- 4 Locate the **Coloring and Style** section. From the **Coloring** list, choose **Color table**.
- 5 From the **Color table** list, choose **TrafficLight**.

Stack Zones

- 1 In the **Model Builder** window, click **Stack Zones**.

- 2 Drag and drop below **Layer Cross-Section Preview**.
- 3 In the **Stack Zones** toolbar, click  **Plot**.