



Model created in COMSOL Multiphysics 6.4

Homogeneous Charge Compression Ignition of Methane

Introduction

Homogeneous Charge Compression Ignition (HCCI) engines are being considered as an alternative to traditional spark- and compression-ignition engines. As the name implies, a homogeneous fuel/oxidant mixture is auto-ignited by compression with simultaneous combustion occurring throughout the cylinder volume. Combustion temperatures under lean burn operation are relatively low, resulting in low levels of NO_x emission.

Furthermore, the fuel's homogeneous nature, as well as the combustion process itself, lead to low levels of particulate matter being produced.

Although HCCI combustion shows promise, the method has several recurring problems: an important one to be addressed is ignition timing. This example examines the HCCI of methane, investigating ignition trends as a function of initial temperature, initial pressure, and fuel additives.

This example solves the mass and energy balances describing the detailed combustion of methane in a variable-volume system. The large amount of kinetic and thermodynamic data required to set up the problem is easily available by importing the relevant files into the Reaction Engineering interface.

Model Definition

It is difficult to form the uniform mixtures required for HCCI with conventional diesel fuel. Natural gas fuels, on the other hand, readily produce homogeneous mixtures and have the potential to serve as HCCI fuels. This example considers the combustion of methane, as described by the GRI-3.0 mechanism, incorporating a detailed reaction mechanism of 53 species taking part in 325 reactions. The files describing the reaction kinetics and thermodynamics of the GRI-3.0 mechanism are available on the Internet ([Ref. 1](#)), and you can import the files into the Reaction Engineering interface.

VARIABLE VOLUME REACTOR

This model represents the combustion cylinder with a perfectly mixed batch system of variable volume, a predefined reactor type available with the Reaction Engineering

interface. Figure 1 shows an engine cylinder and it includes the relevant parameters to calculate the instantaneous cylinder volume.

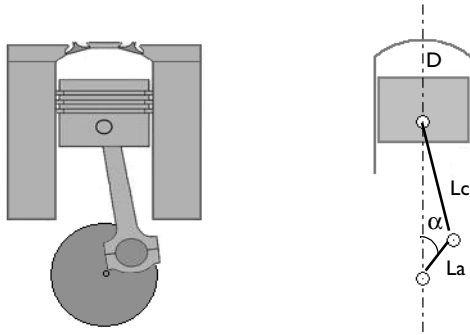

Figure 1: The volume of a combustion cylinder can be expressed as a function of time with the slider-crank relationship. The diagram shows the key geometric parameters. L_a is the length of the crank arm, L_c is the length of the connecting rod, D equals the cylinder diameter, and α is the crank angle.

The volume change as a function of time is described by the slider-crank equation:

$$\frac{V}{V_c} = 1 + \frac{(CR-1)}{2} [R + 1 - \cos \alpha - \sqrt{R^2 - (\sin \alpha)^2}]$$

where V is the cylinder volume (SI unit: m^3), V_c is the clearance volume (SI unit: m^3), CR equals the compression ratio, and R denotes the ratio of the connecting rod to the crank arm (L_c/L_a). Further, α is the crank angle (SI unit: rad), which is also a function of time

$$\alpha = \frac{2\pi N}{60} t$$

where N is the engine speed in rpm, and t is the time (SI unit: s).

The engine specifications are:

Engine specification	Variable name	Value
Bore	D	13 cm
Stroke	S	16 cm
Connecting rod	L_c	26.93 cm
Crank arm	L_a	8 cm
Engine speed	N	1500 rpm
Compression ratio	CR	15

Equation 1 includes the clearance volume V_c , which is calculated from

$$V_c = \frac{V_s}{(CR - 1)} \quad (1)$$

V_s is the volume swept by the piston during a cycle from the equation

$$V_s = \frac{\pi D^2}{4} S$$

Figure 2 shows the calculated cylinder volume as a function of the crank angle. The piston is initially at bottom dead center (BDC), corresponding to a crank angle of -180 degrees.

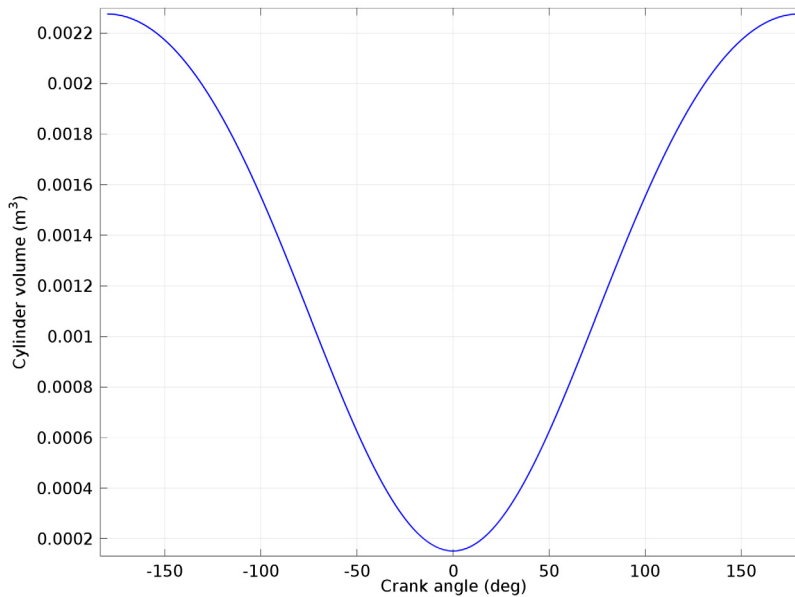

Figure 2: Cylinder volume as a function of crank angle. The crank angle is defined as being zero at top dead center (TDC).

METHANE COMBUSTION REACTION

The kinetic and thermodynamic data for methane combustion is available in the form of CHEMKIN data input files. The files are imported into the Reaction Engineering interface within the Reversible Reaction Group and Species Thermodynamics (belongs to Species Group) features. This automatically sets up the mass and energy balances for a batch reactor.

In this example methane is combusted under lean conditions, that is, supplying more than the stoichiometric amount of oxidizer. The stoichiometric requirement of the oxidizer (air) to combust methane is found from the overall reaction:



Assuming that the composition of air is 21% oxygen and 79% nitrogen, the stoichiometric air-fuel ratio is

$$(A/F)_{\text{stoic}} = \left(\frac{m_{\text{air}}}{m_{\text{fuel}}} \right)_{\text{stoic}} = \frac{4.76 \cdot 2 \cdot M_{\text{air}}}{1 \cdot M_{\text{fuel}}} \quad (2)$$

The equivalence ratio relates the actual air-fuel ratio to the stoichiometric requirements

$$\Phi = \frac{(A/F)_{\text{stoic}}}{(A/F)} \quad (3)$$

This model sets the equivalence ratio to $\Phi = 0.5$.

From [Equation 2](#) and [Equation 3](#) it is possible to calculate the molar fraction of fuel in the reacting mixture as

$$x_{\text{fuel}} = \frac{1}{4.76 \cdot 2 / \Phi + 1}$$

and subsequently the initial concentration is

$$c_{\text{fuel}} = \frac{x_{\text{fuel}} P_{\text{init}}}{RgT_{\text{init}}}$$

Results and Discussion

[Figure 3](#) shows the cylinder pressure as a function of time when a methane-air mixture is compressed and ignites. The piston starts at bottom dead center (BDC) and reaches top

dead center (TDC) after 0.02 s. At BDC the pressure is set to 1.5×10^5 Pa, Φ is 0.5, and the compression ratio is $CR = 15$. The initial temperature is varied from 400 K to 800 K.

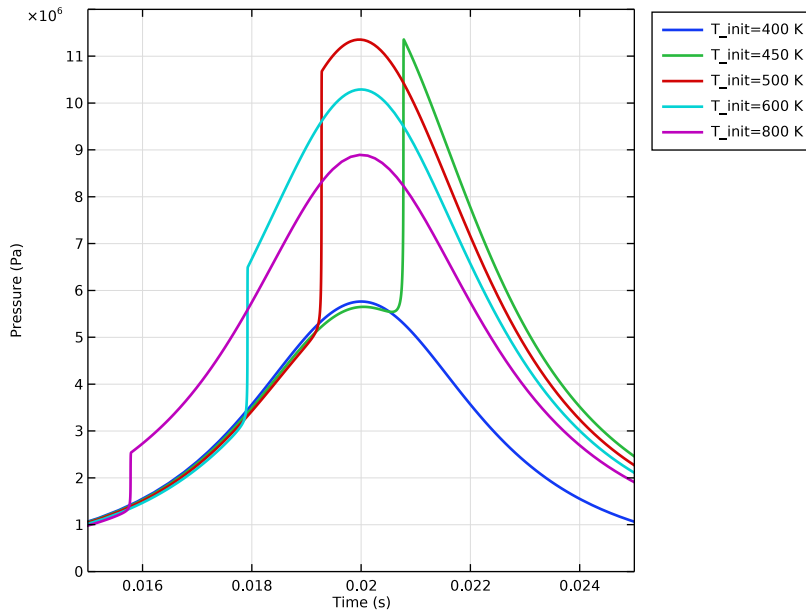

Figure 3: Pressure traces illustrating the compression and ignition of fuel in an engine cylinder. The initial temperature varies between 400 K and 800 K.

Consistent with results in literature, methane does not ignite at an initial temperature of 400 K (Ref. 2). Furthermore, the induction delay decreases with increasing initial temperature. The induction delay time can be evaluated from the pressure gradient. For instance, the induction delay is 0.0193 s when $T_{init} = 500$ K.

Figure 4 illustrates the pressure traces as the initial pressure varies from 1×10^5 Pa to 3×10^5 Pa. The initial temperature is 500 K. An increase in pressure means an increase in

the species concentrations in the fuel-air mixture, resulting in the expected advance in ignition times.

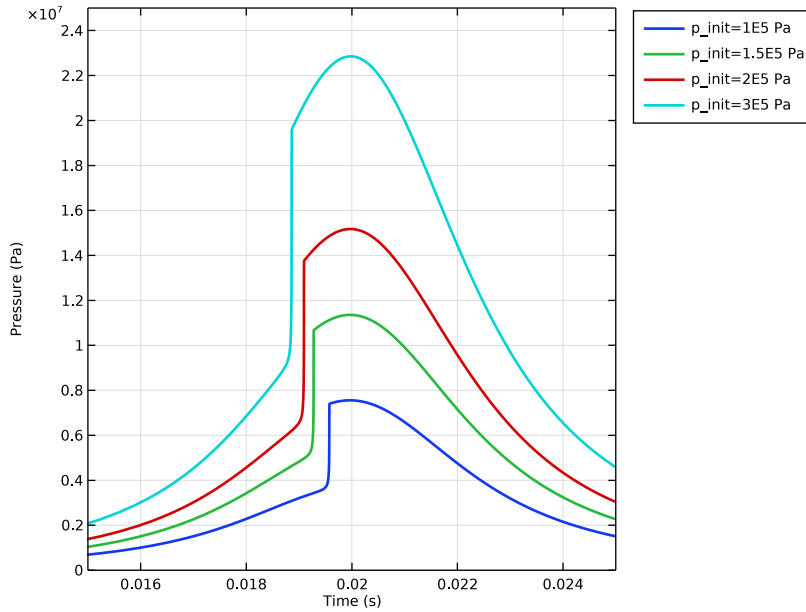

Figure 4: Increased initial gas pressure advances ignition times.

As mentioned, a significant challenge to the realization of HCCI engines is ignition control. In this regard, combustion at TDC is suggested as the optimum timing (Ref. 3). These results show that the inlet temperature of the fuel-air mixture is a potential tuning parameter for ignition. However, relatively high inlet temperatures are often required for proper timing. This adversely affects engine performance because the trapped mass as well as the volumetric efficiency decreases. An alternative that facilitates ignition is to mix small amounts of additives into the fuel-air mixture (Ref. 4). These additives chemically activate the reaction mixture even at relatively low temperatures. This approach alleviates the requirements of high intake temperatures. Figure 5 shows how small amounts of

formaldehyde (CH₂O) cause ignition at an initial temperature of 400 K, which is a temperature insufficient to induce combustion with a pure methane fuel.

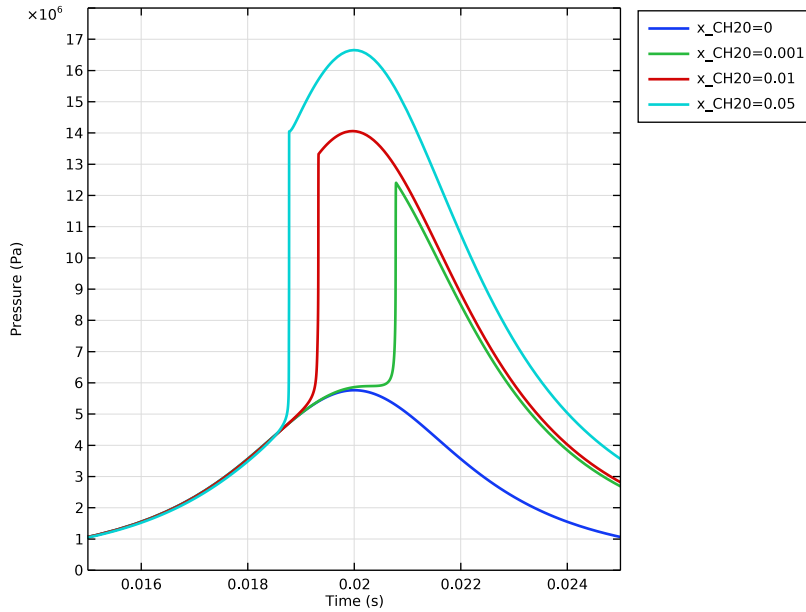

Figure 5: Small amounts of formaldehyde stimulate ignition of the fuel-air mixture.

The increased reactivity observed in the presence of CH₂O is explained by the opening of a new chemical pathway leading to the formation of hydroxyl radicals. Specifically, CH₂O reacts with O₂ to produce H₂O₂:



H₂O₂, in turn, decomposes to reactive OH radicals, which subsequently react violently with the fuel molecules to cause ignition:



The results in the following figures show the species molar fractions of CH₂O, HO₂, H₂O₂, and OH during the combustion of methane. Figure 6 shows molar fraction plots for the case when 0.13% CH₂O is added to the fuel; Figure 7 is the equivalent species plots for the case when pure methane is combusted. In each case conditions are tuned to

produce ignition near TDC, thus providing a reference point for comparing the species concentrations.

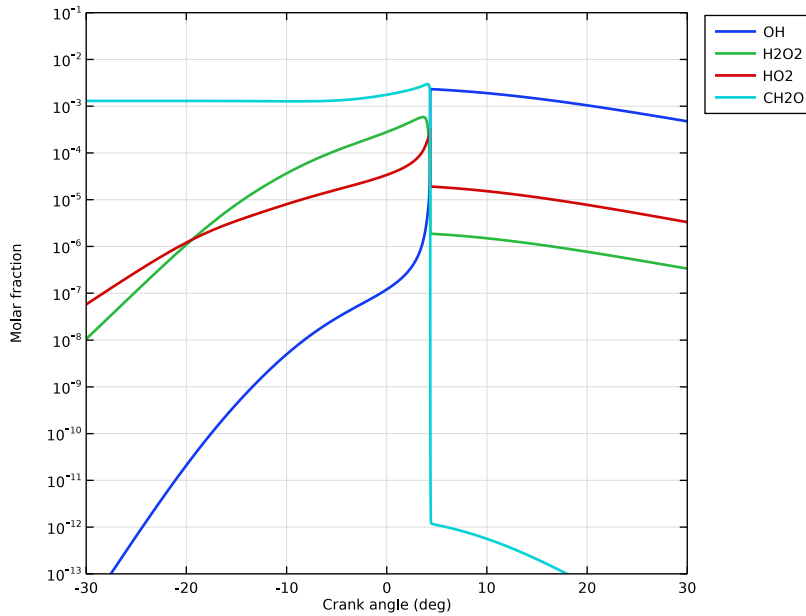

Figure 6: Selected species molar fractions as a function of crank angle. 0.13 molar percent CH_2O is added to the reacting mixture, which is initially at 400 K and 1.5 bar.

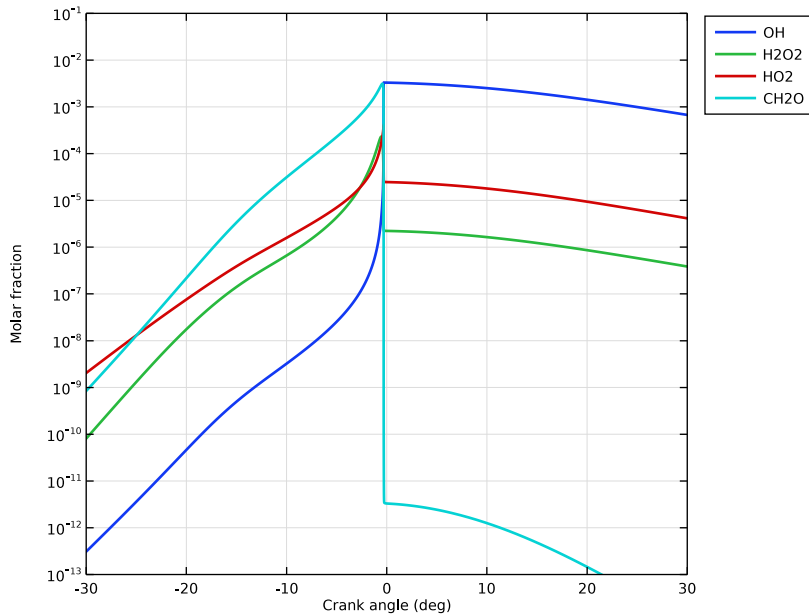

Figure 7: Selected species molar fraction as a function of crank angle. Only methane is combusted. The initial temperature is 469 K and the initial pressure is 1.5 bar.

The implications of the CH_2O reaction path are apparent by comparing Figure 6 and Figure 7: CH_2O stimulates the production of HO_2 and H_2O_2 , which in turn produce OH radicals in amounts critical to fuel ignition.

References

1. G.P. Smith, D.M. Golden, M. Frenklach, N.W. Moriarty, B. Eiteneer, M. Goldenberg, C.T. Bowman, R.K. Hanson, S. Song, W.C. Gardiner, Jr., V.V. Lissianski, and Z. Qin, GRI-Mech 3.0 home page, http://combustion.berkeley.edu/gri_mech/.
2. S.B. Fiveland and D.N. Assanis, "A four-stroke homogeneous charge compression ignition engine simulation for combustion and performance studies," *SAE Paper 2000-01-0332*, 2000.
3. D.L. Flowers, S.M. Aceves, C.K. Westbrook, J.R. Smith, and R.W. Dibble, "Detailed Chemical Kinetic Simulation of Natural Gas HCCI Combustion: Gas Composition Effects and Investigation of Control Strategies," *J. Eng. Gas Turbine Power*, vol. 123, no. 2, pp. 433–439, 2001.

4. M.H. Morsy, “Ignition control of methane fueled homogeneous charge compression ignition engines using additives,” *Fuel*, vol. 86, no. 4, pp. 533–540, 2007.

Application Library path: Chemical_Reaction_Engineering_Module/
Ideal_Tank_Reactors/compression_ignition

Notes about the COMSOL Implementation

The kinetic and thermodynamic data required for this model are available on the Internet. Find the GRI-Mech 3.0 input files at (Ref. 1):

http://combustion.berkeley.edu/gri_mech/version30/text30.html

Download the reaction mechanism and rate coefficient file (`grimech30.dat`), as well as thermodynamic data file (`thermo30.dat`) and store them on your computer so you can import these into the Reaction Engineering interface.



Modeling Instructions

From the **File** menu, choose **New**.

NEW

In the **New** window, click  **Model Wizard**.

MODEL WIZARD

- 1 In the **Model Wizard** window, click  **OD**.
- 2 In the **Select Physics** tree, select **Chemical Species Transport > Reaction Engineering (re)**.
- 3 Click **Add**.
- 4 Click  **Study**.
- 5 In the **Select Study** tree, select **General Studies > Time Dependent**.
- 6 Click  **Done**.

GLOBAL DEFINITIONS

Import the model parameters from a text file.

Parameters 1



- 1 In the **Model Builder** window, under **Global Definitions** click **Parameters 1**.

- 2 In the **Settings** window for **Parameters**, locate the **Parameters** section.
- 3 Click  **Load from File**.
- 4 Browse to the model's Application Libraries folder and double-click the file `compression_ignition_parameters.txt`.

Next, import some necessary variables, among these the cylinder volume function, from a text file.

DEFINITIONS

Variables I



- 1 In the **Model Builder** window, under **Component 1 (comp1)** right-click **Definitions** and choose **Variables**.
- 2 In the **Settings** window for **Variables**, locate the **Variables** section.
- 3 Click  **Load from File**.
- 4 Browse to the model's Application Libraries folder and double-click the file `compression_ignition_variables.txt`.
- 5 Click the  **Show More Options** button in the **Model Builder** toolbar.
- 6 In the **Show More Options** dialog, in the tree, select the checkbox for the node **Physics > Advanced Physics Options**.
- 7 Click **OK**.

REACTION ENGINEERING (RE)

- 1 In the **Model Builder** window, under **Component 1 (comp1)** click **Reaction Engineering (re)**.
- 2 In the **Settings** window for **Reaction Engineering**, locate the **Reactor** section.
- 3 From the **Reactor type** list, choose **Batch**.
- 4 Locate the **Energy Balance** section. From the **Energy balance** list, choose **Include**.
Use uniform scaling of the concentration variables to improve the computational performance.
- 5 Click to expand the **Advanced Settings** section. Select the **Uniform scaling of concentration variables** checkbox.
- 6 Locate the **Reactor** section. Find the **Mass balance** subsection. In the V_r text field, type `Vol`.



Reversible Reaction Group I

Import the reaction kinetics data, available as a CHEMKIN file (`grimech30.dat`).

- 1 In the **Reaction Engineering** toolbar, click  **Reversible Reaction Group**.
- 2 In the **Settings** window for **Reversible Reaction Group**, click to expand the **CHEMKIN Import for Kinetics** section.
- 3 Select the **Import CHEMKIN data** checkbox.
- 4 Click  **Browse**.
- 5 Browse to the model's Application Libraries folder and double-click the file `grimech30.dat`.
- 6 Click  **Import**.

Species Thermodynamics I

Import also the thermodynamic data, available as a CHEMKIN file (`thermo30.dat`).

- 1 In the **Model Builder** window, expand the **Component I (comp1) > Reaction Engineering (re) > Species Group I** node, then click **Species Thermodynamics I**.
- 2 In the **Settings** window for **Species Thermodynamics**, click to expand the **CHEMKIN Import for Thermodynamic Data** section.
- 3 Click  **Browse**.
- 4 Browse to the model's Application Libraries folder and double-click the file `thermo30.dat`.
- 5 Click  **Import**.

Initial Values I

- 1 In the **Model Builder** window, under **Component I (comp1) > Reaction Engineering (re)** click **Initial Values I**.
- 2 In the **Settings** window for **Initial Values**, locate the **General Parameters** section.
- 3 In the T_0 text field, type `T_init`.
- 4 Locate the **Volumetric Species Initial Values** section. In the table, enter the following settings:

Species	Concentration (mol/m ³)
CH2O	c_CH2O_0
CH4	c_CH4_0
N2	c_N2_0
O2	c_O2_0



STUDY 1

Step 1: Time Dependent

Set up the time dependent study, modify the default tolerance settings to improve the accuracy of the solution.

- 1 In the **Model Builder** window, under **Study 1** click **Step 1: Time Dependent**.
- 2 In the **Settings** window for **Time Dependent**, locate the **Study Settings** section.
- 3 In the **Output times** text field, type 0 0.03.
- 4 From the **Tolerance** list, choose **User controlled**.
- 5 In the **Relative tolerance** text field, type 1e-6.

Solution 1 (sol1)

- 1 In the **Study** toolbar, click  **Show Default Solver**.
- 2 In the **Model Builder** window, expand the **Solution 1 (sol1)** node, then click **Time-Dependent Solver 1**.
- 3 In the **Settings** window for **Time-Dependent Solver**, click to expand the **Absolute Tolerance** section.
- 4 Clear the **Update scaled absolute tolerance** checkbox.
- 5 In the **Study** toolbar, click  **Compute**.

RESULTS

Concentration (re)



- 1 In the **Settings** window for **ID Plot Group**, click to expand the **Title** section.
- 2 From the **Title type** list, choose **None**.
- 3 Locate the **Legend** section. From the **Layout** list, choose **Outside graph axis area**.

Global 1

- 1 In the **Model Builder** window, expand the **Concentration (re)** node, then click **Global 1**.
- 2 In the **Settings** window for **Global**, click **Replace Expression** in the upper-right corner of the **y-Axis Data** section. From the menu, choose **Component 1 (comp1) > Reaction Engineering > re.c_N2 - Concentration (N2) - mol/m³**.
- 3 Click **Add Expression** in the upper-right corner of the **y-Axis Data** section. From the menu, choose **Component 1 (comp1) > Reaction Engineering > re.c_O2 - Concentration (O2) - mol/m³**.

- 4 Click **Add Expression** in the upper-right corner of the **y-Axis Data** section. From the menu, choose **Component I (comp1) > Reaction Engineering > re.c_CH4 - Concentration (CH4) - mol/m³**.
- 5 Click **Add Expression** in the upper-right corner of the **y-Axis Data** section. From the menu, choose **Component I (comp1) > Reaction Engineering > re.c_CH2O - Concentration (CH2O) - mol/m³**.
- 6 Click to expand the **Coloring and Style** section. From the **Width** list, choose **2**.
- 7 Click to expand the **Legends** section. From the **Legends** list, choose **Manual**.
- 8 In the table, enter the following settings:

Legends
N2
O2
CH4
CH2O

- 9 In the **Concentration (re)** toolbar, click  **Plot**.
- 10 Click the  **Zoom Extents** button in the **Graphics** toolbar.

Temperature (re)

- 1 In the **Model Builder** window, under **Results** click **Temperature (re)**.
- 2 In the **Settings** window for **ID Plot Group**, locate the **Legend** section.
- 3 Clear the **Show legends** checkbox.

Global I

- 1 In the **Model Builder** window, expand the **Temperature (re)** node, then click **Global I**.
- 2 In the **Settings** window for **Global**, click to expand the **Coloring and Style** section.
- 3 From the **Width** list, choose **2**.
- 4 In the **Temperature (re)** toolbar, click  **Plot**.

The following steps create a plot of the pressure versus time.

ID Plot Group 3

- 1 In the **Results** toolbar, click  **ID Plot Group**.
- 2 In the **Settings** window for **ID Plot Group**, click to expand the **Title** section.
- 3 From the **Title type** list, choose **None**.
- 4 Locate the **Legend** section. From the **Layout** list, choose **Outside graph axis area**.

Global 1

- 1 Right-click **ID Plot Group 3** and choose **Global**.
- 2 In the **Settings** window for **Global**, click **Replace Expression** in the upper-right corner of the **y-Axis Data** section. From the menu, choose **Component 1 (comp1) > Reaction Engineering > re.p - Pressure - Pa**.
- 3 In the **ID Plot Group 3** toolbar, click  **Plot**.

The following steps reproduce [Figure 6](#).

Mole Fraction

- 1 In the **Results** toolbar, click  **ID Plot Group**.
- 2 In the **Settings** window for **ID Plot Group**, type **Mole Fraction** in the **Label** text field.
- 3 Locate the **Title** section. From the **Title type** list, choose **None**.
- 4 Locate the **Plot Settings** section.
- 5 Select the **x-axis label** checkbox. In the associated text field, type **Crank angle (deg)**.
- 6 Select the **y-axis label** checkbox. In the associated text field, type **Molar fraction**.
- 7 Locate the **Axis** section. Select the **Manual axis limits** checkbox.
- 8 In the **x minimum** text field, type **-30**.
- 9 In the **x maximum** text field, type **30**.
- 10 In the **y minimum** text field, type **1e-13**.
- 11 In the **y maximum** text field, type **1e-1**.
- 12 Select the **y-axis log scale** checkbox.
- 13 Locate the **Legend** section. From the **Layout** list, choose **Outside graph axis area**.

Global 1

- 1 Right-click **Mole Fraction** and choose **Global**.
- 2 In the **Settings** window for **Global**, click **Replace Expression** in the upper-right corner of the **y-Axis Data** section. From the menu, choose **Component 1 (comp1) > Reaction Engineering > re.m_OH - Molar fraction - I**.
- 3 Locate the **x-Axis Data** section. From the **Parameter** list, choose **Expression**.
- 4 In the **Expression** text field, type **comp1.crank_angle**.
- 5 Locate the **Coloring and Style** section. From the **Width** list, choose **2**.
- 6 Locate the **Legends** section. From the **Legends** list, choose **Manual**.

7 In the table, enter the following settings:

Legends

OH

Global 2

- 1 In the **Model Builder** window, right-click **Global 1** and choose **Duplicate**.
- 2 In the **Settings** window for **Global**, click **Replace Expression** in the upper-right corner of the **y-Axis Data** section. From the menu, choose **Component 1 (comp1) > Reaction Engineering > re.m_H2O2 - Molar fraction - 1**.
- 3 Locate the **Legends** section. In the table, enter the following settings:

Legends

H2O2

Global 3

- 1 Right-click **Global 2** and choose **Duplicate**.
- 2 In the **Settings** window for **Global**, click **Replace Expression** in the upper-right corner of the **y-Axis Data** section. From the menu, choose **Component 1 (comp1) > Reaction Engineering > re.m_HO2 - Molar fraction - 1**.
- 3 Locate the **Legends** section. In the table, enter the following settings:

Legends

HO2

Global 4

- 1 Right-click **Global 3** and choose **Duplicate**.
- 2 In the **Settings** window for **Global**, click **Replace Expression** in the upper-right corner of the **y-Axis Data** section. From the menu, choose **Component 1 (comp1) > Reaction Engineering > re.m_CH2O - Molar fraction - 1**.
- 3 Locate the **Legends** section. In the table, enter the following settings:

Legends

CH2O

- 4 In the **Mole Fraction** toolbar, click  **Plot**.

The following steps reproduce [Figure 7](#). First change the temperature and the initial CH2O concentration, then resolve.

GLOBAL DEFINITIONS

Parameters I

- 1 In the **Model Builder** window, under **Global Definitions** click **Parameters I**.
- 2 In the **Settings** window for **Parameters**, locate the **Parameters** section.
- 3 In the table, enter the following settings:

Name	Expression	Value	Description
T_init	469[K]	469 K	Initial temperature at BDC
x_CH2O	0	0	Initial CH2O mole fraction

STUDY I

In the **Study** toolbar, click  **Compute**.

RESULTS



Mole Fraction

- 1 In the **Model Builder** window, under **Results** click **Mole Fraction**.
- 2 In the **Mole Fraction** toolbar, click  **Plot**.

To reproduce [Figure 3](#), create a parametric sweep over the initial temperature parameter.

STUDY I

Parametric Sweep

- 1 In the **Study** toolbar, click  **Parametric Sweep**.
- 2 In the **Settings** window for **Parametric Sweep**, locate the **Study Settings** section.
- 3 Click  **Add**.
- 4 In the table, enter the following settings:

Parameter name	Parameter value list	Parameter unit
T_init (Initial temperature at BDC)	400 450 500 600 800	K

- 5 In the **Model Builder** window, click **Study I**.
- 6 In the **Settings** window for **Study**, locate the **Study Settings** section.
- 7 Clear the **Generate default plots** checkbox.
- 8 In the **Study** toolbar, click  **Compute**.

RESULTS

ID Plot Group 3

- 1 In the **Model Builder** window, under **Results** click **ID Plot Group 3**.
- 2 In the **Settings** window for **ID Plot Group**, locate the **Data** section.
- 3 From the **Dataset** list, choose **Study 1/Parametric Solutions 1 (sol2)**.
- 4 In the **ID Plot Group 3** toolbar, click  **Plot**.
- 5 Locate the **Axis** section. Select the **Manual axis limits** checkbox.
- 6 In the **x minimum** text field, type 0.015.
- 7 In the **x maximum** text field, type 0.025.
- 8 In the **y minimum** text field, type 0.
- 9 In the **y maximum** text field, type 1.2e7.

Global 1

- 1 In the **Model Builder** window, click **Global 1**.
- 2 In the **Settings** window for **Global**, locate the **Coloring and Style** section.
- 3 From the **Width** list, choose **2**.
- 4 Locate the **Legends** section. From the **Legends** list, choose **Manual**.
- 5 In the table, enter the following settings:

Legends
T_init=400 K
T_init=450 K
T_init=500 K
T_init=600 K
T_init=800 K

- 6 In the **ID Plot Group 3** toolbar, click  **Plot**.

GLOBAL DEFINITIONS

Parameters 1

To reproduce [Figure 4](#), sweep instead over the initial pressure parameter. Set the initial temperature to 500 K first.

- 1 In the **Model Builder** window, under **Global Definitions** click **Parameters 1**.
- 2 In the **Settings** window for **Parameters**, locate the **Parameters** section.

3 In the table, enter the following settings:

Name	Expression	Value	Description
T_init	500[K]	500 K	Initial temperature at BDC

STUDY 1

Parametric Sweep

- 1 In the **Model Builder** window, under **Study 1** click **Parametric Sweep**.
- 2 In the **Settings** window for **Parametric Sweep**, locate the **Study Settings** section.
- 3 In the table, enter the following settings:

Parameter name	Parameter value list	Parameter unit
p_init (Initial pressure at BDC)	{1 1.5 2 3}*1e5	Pa

- 4 In the **Study** toolbar, click  **Compute**.

RESULTS

ID Plot Group 3

- 1 In the **Settings** window for **ID Plot Group**, locate the **Axis** section.
- 2 In the **y maximum** text field, type 2.5e7.

Global 1

- 1 In the **Model Builder** window, click **Global 1**.
- 2 In the **Settings** window for **Global**, locate the **Legends** section.
- 3 In the table, enter the following settings:

Legends
p_init=1E5 Pa
p_init=1.5E5 Pa
p_init=2E5 Pa
p_init=3E5 Pa

- 4 In the **ID Plot Group 3** toolbar, click  **Plot**.

GLOBAL DEFINITIONS

Parameters I

To reproduce Figure 5, sweep instead over the initial CH₂O mole fraction. Set the initial temperature to 400 K first.

- 1 In the **Model Builder** window, under **Global Definitions** click **Parameters I**.
- 2 In the **Settings** window for **Parameters**, locate the **Parameters** section.
- 3 In the table, enter the following settings:

Name	Expression	Value	Description
T_init	400[K]	400 K	Initial temperature at BDC

STUDY I

Parametric Sweep

- 1 In the **Model Builder** window, under **Study I** click **Parametric Sweep**.
- 2 In the **Settings** window for **Parametric Sweep**, locate the **Study Settings** section.
- 3 In the table, enter the following settings:

Parameter name	Parameter value list	Parameter unit
x_CH ₂ O (Initial CH ₂ O mole fraction)	0 0.001 0.01 0.05	Pa

- 4 In the **Study** toolbar, click  **Compute**.

RESULTS

Reactor Pressure

- 1 In the **Settings** window for **ID Plot Group**, type Reactor Pressure in the **Label** text field.
- 2 Locate the **Axis** section. In the **y maximum** text field, type 1.8e7.

Global I

- 1 In the **Model Builder** window, click **Global I**.
- 2 In the **Settings** window for **Global**, locate the **Legends** section.

3 In the table, enter the following settings:

Legends

x_CH20=0

x_CH20=0.001

x_CH20=0.01

x_CH20=0.05

4 In the **Reactor Pressure** toolbar, click  **Plot**.