



Model created in COMSOL Multiphysics 6.4

Carbon Deposition in Heterogeneous Catalysis

Introduction

Carbon deposition onto the surface of solid catalysts is commonly observed in hydrocarbon processing. Carbon deposits can affect both the activity of catalysts as well as the flow of gas through a catalyst bed.

This example investigates the thermal decomposition of methane into hydrogen and solid carbon with two models. In the first model, the isothermal process occurring in an ideal reactor is simulated with the Reaction Engineering interface. The influence of carbon deposition on catalyst activity is also considered. In the second model, the effect that the carbon deposits have on the porosity and the fluid flow is studied. The second simulation takes both time and space dependencies into account.

Model Definition

CHEMISTRY

Methane decomposes over a Ni/Al₂O₃ catalyst according to the overall chemical reaction

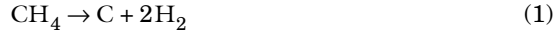

Under atmospheric pressure, the temperature ranging from 490°C to 590°C and a volume fraction of hydrogen between 0 and 40%, the following reaction rate expression has been reported in the literature (Ref. 1):

$$r = k \cdot \frac{P_{\text{CH}_4} - \frac{P_{\text{H}_2}^2}{K_p}}{(1 + k_{\text{H}} \sqrt{P_{\text{H}_2}})^2} \quad (2)$$

where

$$k = k_0 \cdot \exp\left(20.492 - \frac{1.042 \cdot 10^5 \text{ J/mol}}{R_g T}\right) \quad (3)$$

$$k_{\text{H}} = \exp\left(\frac{1.632 \cdot 10^5 \text{ J/mol}}{R_g T} - 22.426\right)$$

and

$$K_p = 5.088 \cdot 10^5 \cdot \exp\left(-\frac{9.12 \cdot 10^4 \text{ J/mol}}{R_g T}\right)$$

The constant k_0 in Equation 3 is $2.31 \cdot 10^{-5} \text{ mol}/(\text{m}^3 \cdot \text{s})$, supposing the amount of catalyst being $1 \text{ g}/\text{m}^3$. The unit for pressure in Equation 2 is bar.

IDEAL REACTOR MODEL

This model treats the isothermal decomposition of methane (Figure 2) in a perfectly mixed batch reactor with constant volume. The species mass balances are summarized by

$$\frac{dc_i}{dt} = R_i$$

The rate term, R_i (SI unit: $\text{mol}/(\text{m}^3 \cdot \text{s})$) for each species, takes into account the reaction stoichiometry coefficients, ν_i , the reaction rate reported in Equation 2, r (SI units: $\text{mol}/(\text{m}^3 \cdot \text{s})$), and the catalyst activity, a :

$$R_i = \nu_i r a$$

The mass balances of the reacting species are then

$$\frac{dc_{CH_4}}{dt} = -r a$$

$$\frac{dc_C}{dt} = r a$$

$$\frac{dc_{H_2}}{dt} = 2r a$$

The time dependence of the catalytic activity is expressed by

$$\frac{da}{dt} = -k_a r^2 c_C a$$

where

$$k_a = k_{a0} \cdot \exp\left(\frac{1.356 \cdot 10^5 \text{ J/mol}}{R_g T} - 32.077\right)$$

where k_{a0} is $6.238 \cdot 10^6 (\text{m}^3/\text{mol})^3 \cdot \text{s}$. Solving the mass balances provides the evolution of the species concentrations over time. The fact that carbon is in the solid phase is taken into

account by removing its effect on gas phase physical properties. The pressure in the reactor is a function of only the methane and hydrogen concentrations:

$$P = R_g T (c_{CH_4} + c_{H_2})$$

SPACE- AND TIME-DEPENDENT MODEL

The second model takes fluid flow, mass transport, heat transfer, and the chemical reaction into account. It is created by the Generate Space-Dependent Model feature available in the Reaction Engineering interface.

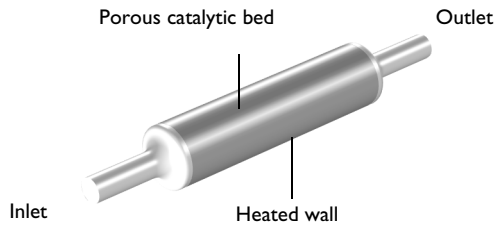

Figure 1: Methane enters from the left and reacts in the porous catalytic bed. The wall of the bed is heated.

EQUATIONS

The space-dependent model solves coupled momentum, mass, and energy balances together with a void fraction balance. The fluid flow is laminar, the concentrations are high (no solvent is present), and porous media with variable porosity exist within the reactor. Additionally, the impact of heating is studied. The following physics interfaces are used in this example:

- Chemistry
- Transport of Concentrated Species
- Heat Transfer in Porous Media
- Laminar Flow
- Domain ODEs and DAEs

The Domain ODEs and DAEs interface solves a balance for the void fraction, or porosity, of the bed given by

$$\frac{d\varepsilon}{dt} = -\frac{\varepsilon r M_C}{\rho_{\text{soot}}}$$

where M_C is the carbon molar weight (SI unit: kg/mol), and ρ_{soot} is the deposited carbon density (SI unit: kg/m³). The equation states that the porosity decreases with the formation rate r of carbon in the pores. The porosity ε on the right hand side is needed to correct the reaction rate to pore volume base, and M_C/ρ_{soot} gives the unit 1/s. This equation can be implemented in the Domain ODEs and DAEs interface, resulting in a porosity distribution across the catalytic bed as a function of time. The initial porosity of the bed is assumed to be $\varepsilon = 0.4$.

The porosity is related to the permeability of the porous domain by (Ref. 2)

$$\kappa = \kappa_0 \left(\frac{\varepsilon}{\varepsilon_0} \right)^{3.55}$$

The reactor geometry (see Figure 1) is set up in 2D axisymmetry in the model as the angular gradients are negligible.

Results and Discussion

IDEAL REACTOR MODEL

Figure 2 shows the concentration transients of methane, hydrogen, and deposited carbon as methane decomposes over a Ni/Al₂O₃ catalyst. The compositions are displayed both with and without catalyst deactivation. From the change in concentrations with time, the reaction rate which does not consider deactivation is higher than when catalyst deactivation is accounted for.

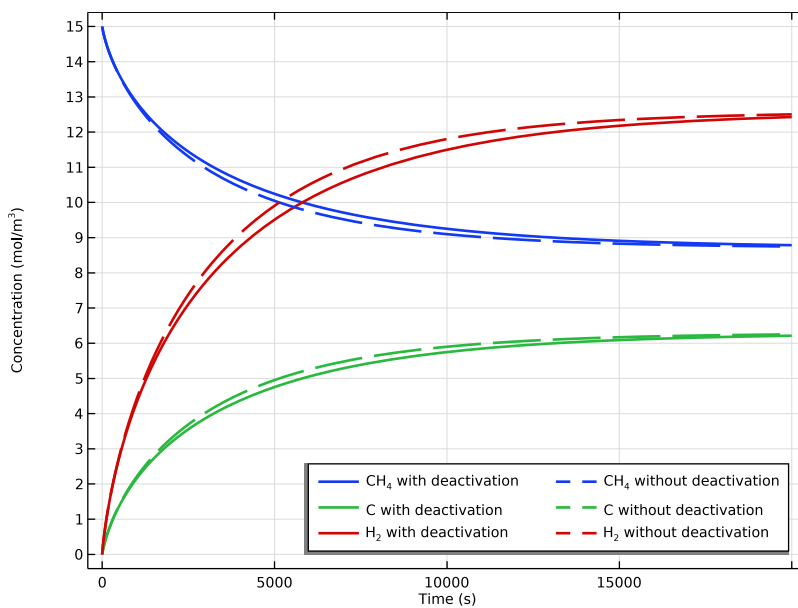

Figure 2: Concentration transients of methane decomposition over a Ni/Al_2O_3 catalyst for two catalyst conditions: 1) with deactivation; 2) without deactivation.

Figure 3 shows the deactivation of the catalyst activity during methane decomposition. The activity decreases rapidly at the early stage of reaction, then decreases slowly.

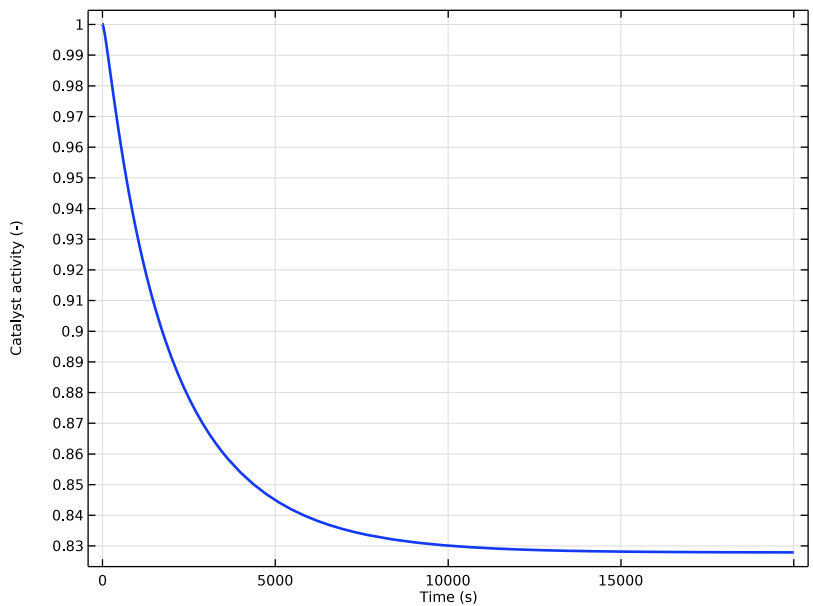

Figure 3: Change of catalyst activity with reacting time.

SPACE- AND TIME-DEPENDENT MODEL

Figure 4 shows the velocity profile (surface) and pressure difference (contour) in the reactor at the end of the simulation. The flow velocity of gas is lower within the porous catalytic bed. The figure also displays the pressure drop across the bed.

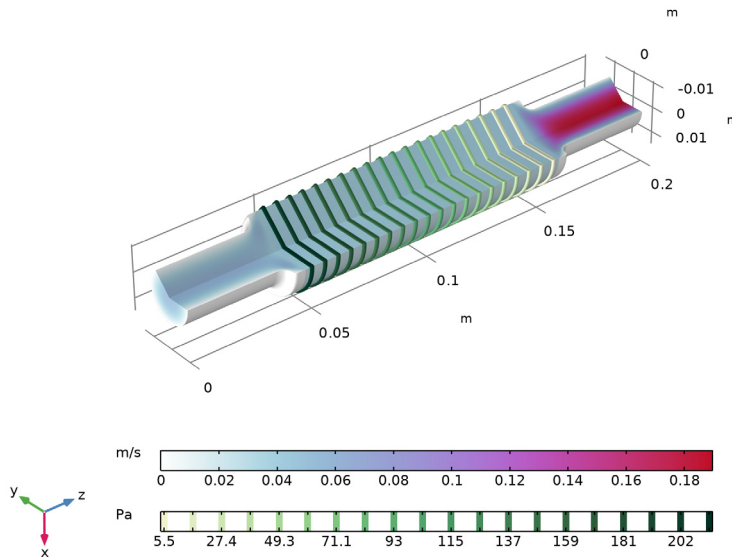

Figure 4: Velocity flow field and pressure drop within the porous catalyst bed after 20,000 s. Surface plot displays the velocity (SI unit: m/s) and contour plot the pressure (SI unit: Pa).

Figure 5 shows the temperature distribution after 50 s and 500 s. It takes approximately 300 s for the bed to heat up to the same temperature as the walls (850 K).

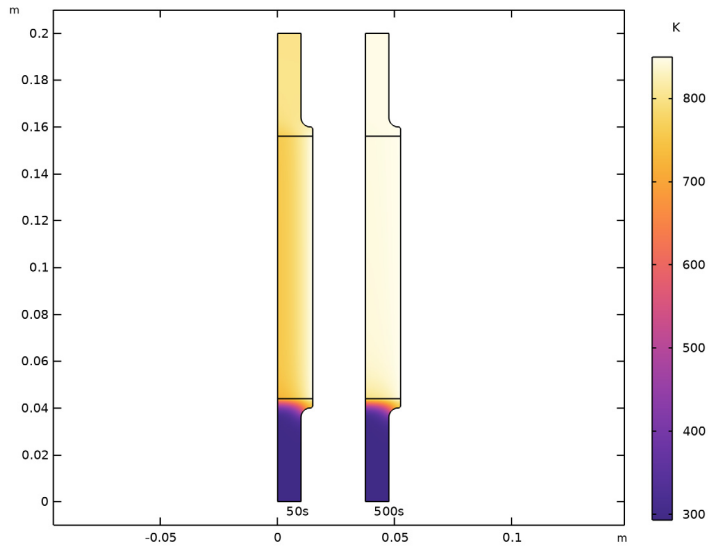

Figure 5: Temperature distribution within the reactor after 50 s and 500 s.

Figure 6 shows a comparison of the concentration distributions for methane and hydrogen at 50 s and 500 s. The concentration of methane decreases quickly as soon as the bed is sufficiently heated (Figure 5).

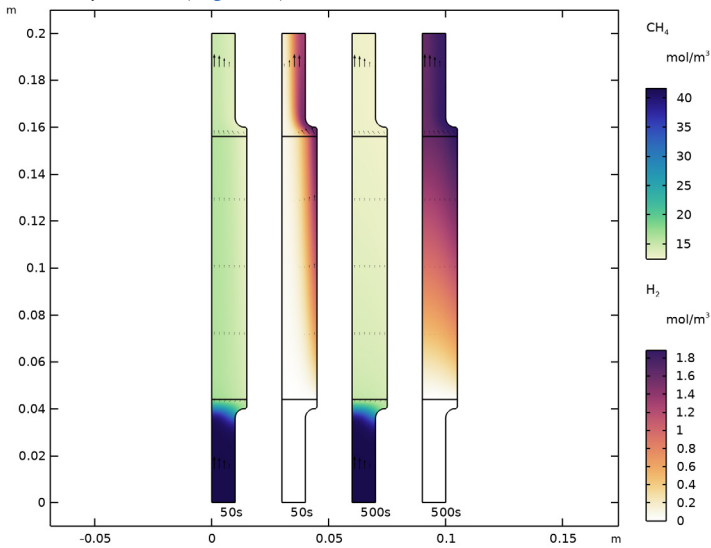

Figure 6: Concentration distribution of methane and hydrogen in the reactor at 50 s and 500 s.

The concentration distribution of methane and hydrogen is displayed along the centerline of the porous catalyst bed in Figure 7. The figure shows that the production of hydrogen varies with time and temperature.

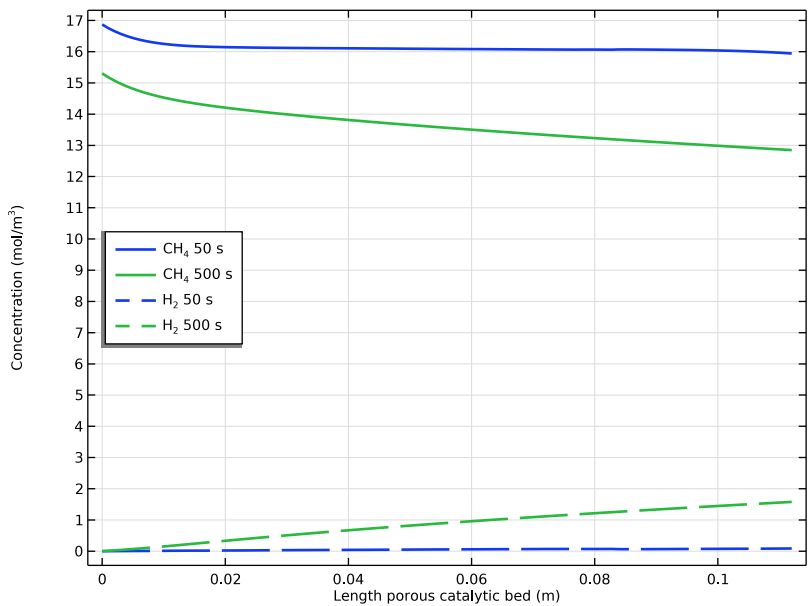

Figure 7: Concentration distribution of CH₄ and H₂ along the center of the porous catalytic bed at 50 s and 500 s.

Figure 8 illustrates that the porosity varies within the bed at 20,000 s and that the pores may become completely clogged near the bed inlet with time.

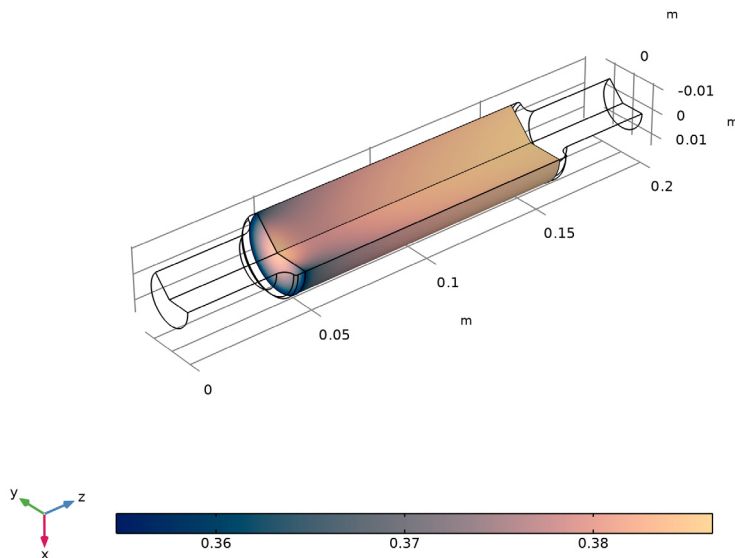

Figure 8: Porosity distribution within the porous catalyst bed at 20,000 s.

References

1. S.G. Zavarukhin and G.G. Kuvshinov, "The kinetic model of formation of nanofibrous carbon from $\text{CH}_4\text{-H}_2$ mixture over a high-loaded nickel catalyst with consideration for the catalyst deactivation," *J. Appl. Catal. A*, vol. 272, pp. 219–227, 2004.
2. E.A. Borisova and P.M. Adler, "Deposition in porous media and clogging on the field scale," *Phys. Rev. E*, vol. 71, p. 016311-1, 2005.

Application Library path: Chemical_Reaction_Engineering_Module/
Reactors_with_Porous_Catalysts/carbon_deposition



Modeling Instructions

From the **File** menu, choose **New**.

NEW

In the **New** window, click  **Model Wizard**.

MODEL WIZARD

- 1 In the **Model Wizard** window, click  **OD**.
- 2 In the **Select Physics** tree, select **Chemical Species Transport** > **Reaction Engineering (re)**.
- 3 Click **Add**.
- 4 Click  **Study**.
- 5 In the **Select Study** tree, select **General Studies** > **Time Dependent**.
- 6 Click  **Done**.

REACTION ENGINEERING (RE)

Reaction 1

- 1 In the **Reaction Engineering** toolbar, click  **Reaction**.
- 2 In the **Settings** window for **Reaction**, locate the **Reaction Formula** section.
- 3 In the **Formula** text field, type $\text{CH}_4 \Rightarrow \text{C} + 2\text{H}_2$.

Species 1

Add an individual species representing the catalyst activity.

- 1 In the **Reaction Engineering** toolbar, click  **Species**.
- 2 In the **Settings** window for **Species**, locate the **Name** section.
- 3 In the text field, type **a**.

When a new species is created a mass balance equation is set up along with it. Note that you can remove the effect of catalyst activity from your model by selecting the **Lock concentration/activity** checkbox. This removes the species mass balance and sets the concentration of the species to the value entered in the **Initial Values** node.

GLOBAL DEFINITIONS

Load the model parameters from a text file.

Parameters 1

- 1 In the **Model Builder** window, under **Global Definitions** click **Parameters 1**.
- 2 In the **Settings** window for **Parameters**, locate the **Parameters** section.
- 3 Click  **Load from File**.

- 4 Browse to the model's Application Libraries folder and double-click the file `carbon_deposition_parameters.txt`.

DEFINITIONS

Load the model variables from a text file.

Variables 1

- 1 In the **Model Builder** window, under **Component 1 (comp1)** right-click **Definitions** and choose **Variables**.
- 2 In the **Settings** window for **Variables**, locate the **Variables** section.
- 3 Click  **Load from File**.
- 4 Browse to the model's Application Libraries folder and double-click the file `carbon_deposition_variables.txt`.
For the k variable definition above, it is assumed that there is $1 \text{ [g/m}^3\text{]}$ catalyst.

REACTION ENGINEERING (RE)

1: $\text{CH}_4 \Rightarrow \text{C} + 2 \text{H}_2$

- 1 In the **Model Builder** window, under **Component 1 (comp1) > Reaction Engineering (re)** click **1: CH₄ => C + 2 H₂**.
- 2 In the **Settings** window for **Reaction**, locate the **Reaction Rate** section.
- 3 From the list, choose **User defined**.
- 4 In the r_j text field, type $\text{re.c}_a * k * (\text{P}_{\text{CH}_4} - \text{P}_{\text{H}_2}^2 / K_p) / (1 + k_H * \text{sqrt}(\text{P}_{\text{H}_2}))^2$.

Additional Source 1

- 1 In the **Reaction Engineering** toolbar, click  **Additional Source**.
- 2 In the **Settings** window for **Additional Source**, locate the **Additional Rate Expression** section.
- 3 In the **Volumetric species** table, enter the following settings:

Species	Additional rate expression (mol/(m ³ s))
a	$-k_a * \text{re.r}_1^2 * \text{re.c}_C * \text{re.c}_a$

Initial Values 1

- 1 In the **Model Builder** window, click **Initial Values 1**.
- 2 In the **Settings** window for **Initial Values**, locate the **Volumetric Species Initial Values** section.

3 In the table, enter the following settings:

Species	Concentration (mol/m ³)
C	0
CH4	c_CH4in
H2	c_H2in
a	1

4 In the **Model Builder** window, click **Reaction Engineering (re)**.

5 In the **Settings** window for **Reaction Engineering**, locate the **Energy Balance** section.

6 In the T text field, type 850[K].

7 Locate the **Mixture Properties** section. From the **Reactor pressure** list, choose **User defined**.

8 In the p text field, type $R_const \cdot re.T \cdot (re.c_CH4 + re.c_H2)$.

STUDY I

Step 1: Time Dependent

1 In the **Model Builder** window, under **Study I** click **Step 1: Time Dependent**.

2 In the **Settings** window for **Time Dependent**, locate the **Study Settings** section.

3 In the **Output times** text field, type range(0,500,20000).

4 In the **Study** toolbar, click  **Compute**.

STUDY I

Solution 1 (sol1)

1 In the **Model Builder** window, expand the **Study I > Solver Configurations** node.

2 Right-click **Solution 1 (sol1)** and choose **Solution > Copy**.

With catalyst deactivation

1 In the **Model Builder** window, under **Study I > Solver Configurations** click **Solution 1 - Copy 1 (sol2)**.

2 In the **Settings** window for **Solution**, type With catalyst deactivation in the **Label** text field.

RESULTS

Catalyst Activity (re)

1 In the **Model Builder** window, under **Results** click **Concentration (re)**.

- 2 In the **Settings** window for **ID Plot Group**, locate the **Data** section.
- 3 From the **Dataset** list, choose **Study 1/With catalyst deactivation (sol2)**.
- 4 In the **Label** text field, type **Catalyst Activity (re)**.
- 5 Click to expand the **Title** section. From the **Title type** list, choose **None**.
- 6 Locate the **Plot Settings** section.
- 7 Select the **y-axis label** checkbox. In the associated text field, type **Catalyst activity (-)**.

Global 1

- 1 In the **Model Builder** window, expand the **Catalyst Activity (re)** node, then click **Global 1**.
- 2 In the **Settings** window for **Global**, click **Replace Expression** in the upper-right corner of the **y-Axis Data** section. From the menu, choose **Component 1 (comp1) > Reaction Engineering > re.c_a - Concentration - mol/m³**.
- 3 Click to expand the **Coloring and Style** section. From the **Width** list, choose **2**.
- 4 Click to expand the **Legends** section. Clear the **Show legends** checkbox.
- 5 In the **Catalyst Activity (re)** toolbar, click  **Plot**.

Now study the reaction when the catalyst activity is held constant (initial value).

REACTION ENGINEERING (RE)

Species: a

- 1 In the **Model Builder** window, under **Component 1 (comp1) > Reaction Engineering (re)** click **Species: a**.
- 2 In the **Settings** window for **Species**, locate the **Constant Concentration/Activity** section.
- 3 Select the **Keep concentration/activity constant** checkbox.

STUDY 1

In the **Study** toolbar, click  **Compute**.

Solution 1 (sol1)

In the **Model Builder** window, under **Study 1 > Solver Configurations** right-click **Solution 1 (sol1)** and choose **Solution > Copy**.

Constant catalyst activity

- 1 In the **Model Builder** window, under **Study 1 > Solver Configurations** click **Solution 1 - Copy 1 (sol3)**.

- 2 In the **Settings** window for **Solution**, type Constant catalyst activity in the **Label** text field.

RESULTS

Compare the concentrations between locked (constant catalyst activity) and unlocked (with catalyst deactivation) species a.

Concentration Comparison (re)

- 1 In the **Model Builder** window, under **Results** click **Concentration (re)**.
- 2 In the **Settings** window for **ID Plot Group**, type Concentration Comparison (re) in the **Label** text field.
- 3 Locate the **Title** section. From the **Title type** list, choose **None**.
- 4 Locate the **Legend** section. From the **Position** list, choose **Lower right**.
- 5 In the **Number of columns** text field, type 2.
- 6 In the **Maximum relative width** text field, type 1.

With catalyst deactivation

- 1 In the **Model Builder** window, expand the **Concentration Comparison (re)** node, then click **Global 1**.
- 2 In the **Settings** window for **Global**, type With catalyst deactivation in the **Label** text field.
- 3 Locate the **Data** section. From the **Dataset** list, choose **Study 1/ With catalyst deactivation (sol2)**.
- 4 Locate the **Coloring and Style** section. From the **Width** list, choose **2**.
- 5 Locate the **Legends** section. From the **Legends** list, choose **Manual**.
- 6 In the table, enter the following settings:

Legends

CH₄ with deactivation

C with deactivation

H₂ with deactivation

Constant catalyst activity

- 1 Right-click **With catalyst deactivation** and choose **Duplicate**.
- 2 In the **Settings** window for **Global**, type Constant catalyst activity in the **Label** text field.

- 3 Locate the **Data** section. From the **Dataset** list, choose **Study 1/ Constant catalyst activity (sol3)**.
- 4 Locate the **Coloring and Style** section. Find the **Line style** subsection. From the **Line** list, choose **Dashed**.
- 5 From the **Color** list, choose **Cycle (reset)**.
- 6 Locate the **Legends** section. In the table, enter the following settings:

Legends
CH ₄ without deactivation
C without deactivation
H ₂ without deactivation

- 7 In the **Concentration Comparison (re)** toolbar, click  **Plot**.

Create a time- and space-dependent model from the **Reaction Engineering** interface. All solid species should be locked before this is done.

REACTION ENGINEERING (RE)

Species: C

- 1 In the **Model Builder** window, under **Component 1 (comp1) > Reaction Engineering (re)** click **Species: C**.
- 2 In the **Settings** window for **Species**, locate the **Constant Concentration/Activity** section.
- 3 Select the **Keep concentration/activity constant** checkbox.

Generate Space-Dependent Model 1

- 1 In the **Reaction Engineering** toolbar, click  **Generate Space-Dependent Model**.
- 2 In the **Settings** window for **Generate Space-Dependent Model**, locate the **Component Settings** section.
- 3 From the **Component to use** list, choose **2Daxi: New**.
- 4 Locate the **Physics Interfaces** section. Find the **Chemical species transport** subsection. From the list, choose **Transport of Concentrated Species: New**.
- 5 Find the **Heat transfer** subsection. From the list, choose **Heat Transfer in Porous Media: New**.
- 6 Find the **Fluid flow** subsection. From the list, choose **Laminar Flow: New**.
- 7 Locate the **Space-Dependent Model Generation** section. Click **Create/Refresh**.

DEFINITIONS (COMP2)

Add variables for the **Chemistry** node which are similar to those used in the **Reaction Engineering** interface.

Variables 2

- 1 In the **Model Builder** window, expand the **Component 2 (comp2)** node.
- 2 Right-click **Component 2 (comp2)** > **Definitions** and choose **Variables**.
- 3 In the **Settings** window for **Variables**, locate the **Variables** section.
- 4 Click  **Load from File**.
- 5 Browse to the model's Application Libraries folder and double-click the file `carbon_deposition_2D_variables.txt`.

In order to get significant carbon deposition, the amount of catalyst is increased to $300[\text{g}/\text{m}^3]$. The k value is 300 times as that in 0D.

GEOMETRY 1 (2DAXI)



Rectangle 1 (r1)

- 1 In the **Geometry** toolbar, click  **Rectangle**.
- 2 In the **Settings** window for **Rectangle**, locate the **Size and Shape** section.
- 3 In the **Width** text field, type 0.01.
- 4 In the **Height** text field, type 0.04.



Rectangle 2 (r2)

- 1 In the **Geometry** toolbar, click  **Rectangle**.
- 2 In the **Settings** window for **Rectangle**, locate the **Size and Shape** section.
- 3 In the **Width** text field, type 0.015.
- 4 In the **Height** text field, type 0.12.
- 5 Locate the **Position** section. In the **z** text field, type 0.04.



Rectangle 3 (r3)

- 1 In the **Geometry** toolbar, click  **Rectangle**.
- 2 In the **Settings** window for **Rectangle**, locate the **Size and Shape** section.
- 3 In the **Width** text field, type 0.01.
- 4 In the **Height** text field, type 0.04.
- 5 Locate the **Position** section. In the **z** text field, type 0.16.
- 6 Click  **Build All Objects**.

Fillet 1 (fil1)

- 1 In the **Geometry** toolbar, click  **Fillet**.
- 2 On the object **r2**, select Points 2 and 3 only.
- 3 In the **Settings** window for **Fillet**, locate the **Radius** section.
- 4 In the **Radius** text field, type 0.001.
- 5 Click  **Build All Objects**.



Union 1 (uni1)

- 1 In the **Geometry** toolbar, click  **Booleans and Partitions** and choose **Union**.
- 2 Click in the **Graphics** window and then press Ctrl+A to select all objects.
- 3 In the **Settings** window for **Union**, locate the **Union** section.
- 4 Clear the **Keep interior boundaries** checkbox.
- 5 Click  **Build All Objects**.

Fillet 2 (fil2)

- 1 In the **Geometry** toolbar, click  **Fillet**.
- 2 On the object **uni1**, select Points 6 and 7 only.
- 3 In the **Settings** window for **Fillet**, locate the **Radius** section.
- 4 In the **Radius** text field, type 0.004.

Rectangle 4 (r4)

- 1 In the **Geometry** toolbar, click  **Rectangle**.
- 2 In the **Settings** window for **Rectangle**, locate the **Size and Shape** section.
- 3 In the **Width** text field, type 0.015.
- 4 In the **Height** text field, type 0.112.
- 5 Locate the **Position** section. In the **z** text field, type 0.044.
- 6 Click  **Build All Objects**.
- 7 Click the  **Zoom Extents** button in the **Graphics** toolbar.

COMPONENT 2 (COMP2)

Add the **Domain ODE and DAE** interface for modeling of the porosity change in the porous domain.

ADD PHYSICS

- 1 In the **Home** toolbar, click  **Add Physics** to open the **Add Physics** window.
- 2 Go to the **Add Physics** window.

- 3 In the tree, select **Mathematics > ODE and DAE Interfaces > Domain ODEs and DAEs (dode)**.
- 4 Click the **Add to Component 2** button in the window toolbar.
- 5 In the **Home** toolbar, click  **Add Physics** to close the **Add Physics** window.

POROSITY CHANGE

- 1 In the **Settings** window for **Domain ODEs and DAEs**, type Porosity Change in the **Label** text field.
- 2 Locate the **Domain Selection** section. Click  **Clear Selection**.
- 3 Select Domain 2 only.
- 4 Locate the **Units** section. In the **Source term quantity** table, enter the following settings:

Source term quantity	Unit
Custom unit	1/s

- 5 Click to expand the **Dependent Variables** section. In the **Field name (I)** text field, type *por*.
- 6 In the **Dependent variables (I)** table, enter the following settings:

<i>por</i>

Distributed ODE 1

- 1 In the **Model Builder** window, under **Component 2 (comp2) > Porosity Change (dode)** click **Distributed ODE 1**.
- 2 In the **Settings** window for **Distributed ODE**, locate the **Source Term** section.
- 3 In the *f* text field, type $-por \cdot \text{chem.r}_1 \cdot \text{chem.M}_C / \rho_{\text{soot}}$.

Initial Values 1

- 1 In the **Model Builder** window, click **Initial Values 1**.
- 2 In the **Settings** window for **Initial Values**, locate the **Initial Values** section.
- 3 In the *por* text field, type *por0*.

CHEMISTRY (CHEM)

Species: CH4

- 1 In the **Model Builder** window, expand the **Component 2 (comp2) > Chemistry (chem)** node, then click **Species: CH4**.
- 2 In the **Settings** window for **Species**, click to expand the **Transport Expressions** section.
- 3 From the **Thermal conductivity** list, choose **User defined**.

- 4 In the k text field, type kt_CH4 .
- 5 Click to expand the **Thermodynamic Expressions** section. From the list, choose **User defined**.
- 6 In the C_p text field, type $Cp_CH4*chem.M_CH4$.
- 7 In the h text field, type h_CH4 .
- 8 In the s text field, type s_CH4 .

Species: H2

- 1 In the **Model Builder** window, click **Species: H2**.
- 2 In the **Settings** window for **Species**, locate the **Transport Expressions** section.
- 3 From the **Thermal conductivity** list, choose **User defined**.
- 4 In the k text field, type kt_H2 .
- 5 Locate the **Thermodynamic Expressions** section. From the list, choose **User defined**.
- 6 In the C_p text field, type $Cp_H2*chem.M_H2$.
- 7 In the h text field, type h_H2 .
- 8 In the s text field, type s_H2 .

Species: C (Constant)

- 1 In the **Model Builder** window, click **Species: C (Constant)**.
- 2 In the **Settings** window for **Species**, locate the **Transport Expressions** section.
- 3 From the **Thermal conductivity** list, choose **User defined**.
- 4 In the k text field, type kt_C .
- 5 Locate the **Thermodynamic Expressions** section. From the list, choose **User defined**.
- 6 In the C_p text field, type $Cp_C*chem.M_C$.
- 7 In the h text field, type h_C .
- 8 In the s text field, type s_C .

Species: a (Constant)

- 1 In the **Model Builder** window, click **Species: a (Constant)**.
- 2 In the **Settings** window for **Species**, locate the **Chemical Formula** section.
- 3 In the M text field, type M_a .
- 4 Locate the **Transport Expressions** section. From the **Thermal conductivity** list, choose **User defined**.
- 5 In the k text field, type kt_cat .

6 Locate the **Thermodynamic Expressions** section. From the list, choose **User defined**.

TRANSPORT OF CONCENTRATED SPECIES (TCS)

1 In the **Model Builder** window, under **Component 2 (comp2)** click **Transport of Concentrated Species (tcs)**.

2 In the **Settings** window for **Transport of Concentrated Species**, locate the **Transport Mechanisms** section.

3 Select the **Mass transfer in porous media** checkbox.

Fluid 1

1 In the **Model Builder** window, expand the **Transport of Concentrated Species (tcs)** node, then click **Fluid 1**.

2 In the **Settings** window for **Fluid**, locate the **Diffusion** section.

3 In the table, enter the following settings:

Species 1	Species 2	Diffusivity	Diffusion coefficient (m ² /s)
wCH4	wH2	User defined	D_CH4H2

Reaction Sources 1

1 In the **Model Builder** window, click **Reaction Sources 1**.

2 Select Domain 2 only.

Inflow 1

1 In the **Physics** toolbar, click  **Boundaries** and choose **Inflow**.

2 Select Boundary 2 only.

3 In the **Settings** window for **Inflow**, locate the **Inflow** section.

4 In the $\omega_{0,wH2}$ text field, type 0.

Outflow 1

1 In the **Physics** toolbar, click  **Boundaries** and choose **Outflow**.

2 Select Boundary 9 only.

Porous Medium 1

1 In the **Physics** toolbar, click  **Domains** and choose **Porous Medium**.

2 Select Domain 2 only.

Fluid 1

1 In the **Model Builder** window, click **Fluid 1**.

2 In the **Settings** window for **Fluid**, click to expand the **Model Input** section.

- 3 From the p_A list, choose **Absolute pressure (spf)**.
- 4 Locate the **Convection** section. From the \mathbf{u} list, choose **Velocity field (spf)**.
- 5 Locate the **Diffusion** section. In the table, enter the following settings:

Species 1	Species 2	Diffusivity	Diffusion coefficient (m ² /s)
wCH4	wH2	User defined	D_CH4H2

Porous Matrix 1

- 1 In the **Model Builder** window, click **Porous Matrix 1**.
- 2 In the **Settings** window for **Porous Matrix**, locate the **Matrix Properties** section.
- 3 In the ε_p text field, type por.

HEAT TRANSFER IN POROUS MEDIA (HT)

Fluid 1

- 1 In the **Model Builder** window, expand the **Component 2 (comp2)** > **Heat Transfer in Porous Media (ht)** > **Porous Medium 1** node, then click **Fluid 1**.
- 2 In the **Settings** window for **Fluid**, locate the **Thermodynamics, Fluid** section.
- 3 From the M_n list, choose **Mean molar mass (chem)**.

Porous Matrix 1

- 1 In the **Model Builder** window, click **Porous Matrix 1**.
- 2 In the **Settings** window for **Porous Matrix**, locate the **Matrix Properties** section.
- 3 From the ε_p list, choose **User defined**. In the associated text field, type por.
- 4 From the **Define** list, choose **Solid phase properties**.
- 5 Locate the **Heat Conduction, Porous Matrix** section. From the k_s list, choose **User defined**. In the associated text field, type kt_cat.
- 6 Locate the **Thermodynamics, Porous Matrix** section. From the ρ_s list, choose **User defined**. In the associated text field, type rho_cat.
- 7 From the $C_{p,s}$ list, choose **User defined**. In the associated text field, type Cp_cat.

Temperature 1

- 1 In the **Physics** toolbar, click  **Boundaries** and choose **Temperature**.
- 2 Select Boundary 2 only.

Outflow 1

- 1 In the **Physics** toolbar, click  **Boundaries** and choose **Outflow**.

2 Select Boundary 9 only.

Temperature 2

- 1 In the **Physics** toolbar, click  **Boundaries** and choose **Temperature**.
- 2 Select Boundary 13 only.
- 3 In the **Settings** window for **Temperature**, locate the **Temperature** section.
- 4 In the T_0 text field, type 850[K].

Fluid 1

- 1 In the **Physics** toolbar, click  **Domains** and choose **Fluid**.
- 2 Select Domains 1 and 3 only.

LAMINAR FLOW (SPF)

- 1 In the **Model Builder** window, under **Component 2 (comp2)** click **Laminar Flow (spf)**.
- 2 In the **Settings** window for **Laminar Flow**, locate the **Physical Model** section.
- 3 Select the **Enable porous media domains** checkbox.

Porous Medium 1

- 1 In the **Physics** toolbar, click  **Domains** and choose **Porous Medium**.
- 2 Select Domain 2 only.

Porous Matrix 1

- 1 In the **Model Builder** window, click **Porous Matrix 1**.
- 2 In the **Settings** window for **Porous Matrix**, locate the **Matrix Properties** section.
- 3 From the ϵ_p list, choose **User defined**. In the associated text field, type por.
- 4 From the κ list, choose **User defined**. In the associated text field, type kappa.

Inlet 1

- 1 In the **Physics** toolbar, click  **Boundaries** and choose **Inlet**.
- 2 Select Boundary 2 only.
- 3 In the **Settings** window for **Inlet**, locate the **Boundary Condition** section.
- 4 From the list, choose **Fully developed flow**.
- 5 Locate the **Fully Developed Flow** section. In the U_{av} text field, type u_in.

Outlet 1



- 1 In the **Physics** toolbar, click  **Boundaries** and choose **Outlet**.
- 2 Select Boundary 9 only.

STUDY 2

Step 1: Stationary

- 1 In the **Model Builder** window, expand the **Study 2** node, then click **Step 1: Stationary**.
- 2 In the **Settings** window for **Stationary**, locate the **Physics and Variables Selection** section.
- 3 In the **Solve for** column of the table, under **Component 2 (comp2)**, clear the checkboxes for **Chemistry (chem)**, **Transport of Concentrated Species (tcs)**, **Heat Transfer in Porous Media (ht)**, and **Porosity Change (dode)**.

Step 2: Time Dependent

- 1 In the **Study** toolbar, click  **Time Dependent**.
- 2 In the **Settings** window for **Time Dependent**, locate the **Study Settings** section.
- 3 In the **Output times** text field, type range (0, 50, 1000) range (2000, 1000, 20000).
- 4 Locate the **Physics and Variables Selection** section. In the **Solve for** column of the table, under **Component 1 (comp1)**, clear the checkbox for **Reaction Engineering (re)**.
- 5 In the **Study** toolbar, click  **Compute**.

Begin by modifying the default plots, and making use of the available **Result Templates**.

Delete the default concentration plots.

RESULTS

*Concentration, CH4 (tcs), Concentration, CH4, 3D (tcs), Concentration, H2 (tcs),
Concentration, H2, 3D (tcs)*

- 1 In the **Model Builder** window, under **Results**, Ctrl-click to select **Concentration, CH4 (tcs)**, **Concentration, CH4, 3D (tcs)**, **Concentration, H2 (tcs)**, and **Concentration, H2, 3D (tcs)**.
- 2 Right-click and choose **Delete**.

RESULT TEMPLATES

- 1 In the **Home** toolbar, click  **Windows** and choose **Result Templates**.
- 2 Go to the **Result Templates** window.
- 3 In the tree, select **Study 2/Solution 4 (5) (sol4) > Transport of Concentrated Species > Plot array: Concentrations, CH4, H2 (tcs)**.
- 4 Click the **Add Result Template** button in the window toolbar.

Using the result template plot as a base, edit it to show the concentration change in the system for both methane and hydrogen.

RESULTS

Plot array: Concentrations, CH4, H2 (tcs)

- 1 In the **Settings** window for **2D Plot Group**, locate the **Data** section.
- 2 From the **Time (s)** list, choose **50**.
- 3 Click to expand the **Title** section. From the **Title type** list, choose **None**.
- 4 Click to expand the **Plot Array** section. In the **Relative padding** text field, type 1.

Surface, CH4

- 1 In the **Model Builder** window, expand the **Plot array: Concentrations, CH4, H2 (tcs)** node, then click **Surface, CH4**.
- 2 In the **Settings** window for **Surface**, locate the **Coloring and Style** section.
- 3 In the **Color legend title** text field, type CH₄.

CH4

- 1 In the **Model Builder** window, expand the **Results > Plot array: Concentrations, CH4, H2 (tcs)** node, then click **CH4**.
- 2 In the **Settings** window for **Annotation**, locate the **Annotation** section.
- 3 In the **Text** text field, type 50s.

Surface, H2

- 1 In the **Model Builder** window, click **Surface, H2**.
- 2 In the **Settings** window for **Surface**, locate the **Coloring and Style** section.
- 3 From the **Color table** list, choose **Iodinea**.
- 4 In the **Color legend title** text field, type H₂.

H2

- 1 In the **Model Builder** window, click **H2**.
- 2 In the **Settings** window for **Annotation**, locate the **Annotation** section.
- 3 In the **Text** text field, type 50s.

CH4, H2, Surface, CH4, Surface, H2, Total Flux, CH4, Total Flux, H2

- 1 In the **Model Builder** window, under **Results > Plot array: Concentrations, CH4, H2 (tcs)**, Ctrl-click to select **Surface, CH4, Total Flux, CH4, CH4, Surface, H2, Total Flux, H2**, and **H2**.
- 2 Right-click and choose **Duplicate**.

Surface, CH4.1

- 1 In the **Model Builder** window, click **Surface, CH4.1**.

- 2 In the **Settings** window for **Surface**, locate the **Data** section.
- 3 From the **Dataset** list, choose **Study 2/Solution 4 (5) (sol4)**.
- 4 From the **Time (s)** list, choose **500**.
- 5 Click to expand the **Inherit Style** section. From the **Plot** list, choose **Surface, CH4**.
- 6 Click to expand the **Plot Array** section. In the **Index** text field, type 2.

Total Flux, CH4.1

- 1 In the **Model Builder** window, click **Total Flux, CH4.1**.
- 2 In the **Settings** window for **Arrow Surface**, locate the **Data** section.
- 3 From the **Dataset** list, choose **Study 2/Solution 4 (5) (sol4)**.
- 4 From the **Time (s)** list, choose **500**.
- 5 Click to expand the **Plot Array** section. In the **Index** text field, type 2.

CH4.1

- 1 In the **Model Builder** window, click **CH4.1**.
- 2 In the **Settings** window for **Annotation**, locate the **Annotation** section.
- 3 In the **Text** text field, type 500s.
- 4 Click to expand the **Plot Array** section. In the **Index** text field, type 2.

Surface, H2.1



- 1 In the **Model Builder** window, click **Surface, H2.1**.
- 2 In the **Settings** window for **Surface**, locate the **Data** section.
- 3 From the **Dataset** list, choose **Study 2/Solution 4 (5) (sol4)**.
- 4 From the **Time (s)** list, choose **500**.
- 5 Locate the **Plot Array** section. In the **Index** text field, type 3.
- 6 Locate the **Inherit Style** section. From the **Plot** list, choose **Surface, H2**.

Total Flux, H2.1

- 1 In the **Model Builder** window, click **Total Flux, H2.1**.
- 2 In the **Settings** window for **Arrow Surface**, locate the **Data** section.
- 3 From the **Dataset** list, choose **Study 2/Solution 4 (5) (sol4)**.
- 4 From the **Time (s)** list, choose **500**.
- 5 Locate the **Plot Array** section. In the **Index** text field, type 3.

H2.1

- 1 In the **Model Builder** window, click **H2.1**.

- 2 In the **Settings** window for **Annotation**, locate the **Annotation** section.
- 3 In the **Text** text field, type 500s.
- 4 Locate the **Plot Array** section. In the **Index** text field, type 3.
- 5 In the **Plot array: Concentrations, CH4, H2 (tcs)** toolbar, click  **Plot**.
- 6 Click the  **Zoom Extents** button in the **Graphics** toolbar.

Modify the default temperature 2D plot.

Temperature (ht)

- 1 In the **Model Builder** window, under **Results** click **Temperature (ht)**.
- 2 In the **Settings** window for **2D Plot Group**, locate the **Data** section.
- 3 From the **Time (s)** list, choose **50**.
- 4 Locate the **Title** section. From the **Title type** list, choose **None**.
- 5 Locate the **Color Legend** section. Select the **Show units** checkbox.
- 6 Click to expand the **Plot Array** section. Select the **Enable** checkbox.
- 7 In the **Relative padding** text field, type 1.5.

CH4

- 1 In the **Model Builder** window, expand the **Temperature (ht)** node.
- 2 Right-click **Results > Plot array: Concentrations, CH4, H2 (tcs) > CH4** and choose **Copy**.

50s

- 1 In the **Model Builder** window, right-click **Temperature (ht)** and choose **Paste Annotation**.
- 2 In the **Settings** window for **Annotation**, type 50s in the **Label** text field.

50s, Surface 1

- 1 In the **Model Builder** window, under **Results > Temperature (ht)**, Ctrl-click to select **Surface 1** and **50s**.
- 2 Right-click and choose **Duplicate**.



Surface 2

- 1 In the **Model Builder** window, click **Surface 2**.
- 2 In the **Settings** window for **Surface**, locate the **Data** section.
- 3 From the **Dataset** list, choose **Study 2/Solution 4 (5) (sol4)**.
- 4 From the **Solution parameters** list, choose **Manual**.
- 5 From the **Time (s)** list, choose **500**.
- 6 Locate the **Inherit Style** section. From the **Plot** list, choose **Surface 1**.

500s

- 1 In the **Model Builder** window, click **50s I**.
- 2 In the **Settings** window for **Annotation**, locate the **Plot Array** section.
- 3 In the **Index** text field, type 1.
- 4 In the **Label** text field, type 500s.
- 5 Locate the **Annotation** section. In the **Text** text field, type 500s.
- 6 Click to expand the **Inherit Style** section. From the **Plot** list, choose **Surface I**.

Temperature (ht)

- 1 In the **Model Builder** window, click **Temperature (ht)**.
- 2 In the **Temperature (ht)** toolbar, click  **Plot**.
- 3 Click the  **Zoom Extents** button in the **Graphics** toolbar.

Modify the default velocity 3D plot.

Velocity and Pressure, 3D (spf)

- 1 In the **Model Builder** window, click **Velocity, 3D (spf)**.
- 2 In the **Settings** window for **3D Plot Group**, click to expand the **Title** section.
- 3 From the **Title type** list, choose **None**.
- 4 In the **Label** text field, type Velocity and Pressure, 3D (spf).
- 5 Locate the **Color Legend** section. Select the **Show units** checkbox.
- 6 From the **Position** list, choose **Bottom**.
- 7 Locate the **Plot Settings** section. Clear the **Plot dataset edges** checkbox.

Surface

- 1 In the **Model Builder** window, expand the **Velocity and Pressure, 3D (spf)** node, then click **Surface**.
- 2 In the **Settings** window for **Surface**, locate the **Coloring and Style** section.
- 3 From the **Color table** list, choose **Acanthaster**.

Contour I

- 1 In the **Model Builder** window, right-click **Velocity and Pressure, 3D (spf)** and choose **Contour**.
- 2 In the **Settings** window for **Contour**, locate the **Expression** section.
- 3 In the **Expression** text field, type p.
- 4 Locate the **Coloring and Style** section. From the **Contour type** list, choose **Tube**.

- 5 From the **Color table** list, choose **Bryophyta**.

Velocity and Pressure, 3D (spf)

- 1 In the **Model Builder** window, click **Velocity and Pressure, 3D (spf)**.
- 2 In the **Settings** window for **3D Plot Group**, locate the **Plot Settings** section.
- 3 From the **View** list, choose **View 3D 2**.
- 4 In the **Velocity and Pressure, 3D (spf)** toolbar, click  **Plot**.

Cut Line 3D 1

- 1 In the **Results** toolbar, click  **Cut Line 3D**.
- 2 In the **Settings** window for **Cut Line 3D**, locate the **Line Data** section.
- 3 In row **Point 1**, set **z** to 0.044.
- 4 In row **Point 2**, set **x** to 0 and **z** to 0.156.

Concentration CH4, Porous Catalyst Bed Center

- 1 In the **Results** toolbar, click  **ID Plot Group**.
- 2 In the **Settings** window for **ID Plot Group**, type Concentration CH4, Porous Catalyst Bed Center in the **Label** text field.
- 3 Locate the **Data** section. From the **Dataset** list, choose **Cut Line 3D 1**.
- 4 From the **Time selection** list, choose **From list**.
- 5 In the **Times (s)** list, choose **50** and **500**.
- 6 Click to expand the **Title** section. From the **Title type** list, choose **None**.
- 7 Locate the **Plot Settings** section.
- 8 Select the **x-axis label** checkbox. In the associated text field, type Length porous catalytic bed (m).
- 9 Select the **y-axis label** checkbox. In the associated text field, type Concentration (mol/m³).
- 10 Locate the **Legend** section. From the **Position** list, choose **Middle left**.

Line Graph 1

- 1 Right-click **Concentration CH4, Porous Catalyst Bed Center** and choose **Line Graph**.
- 2 In the **Settings** window for **Line Graph**, click **Replace Expression** in the upper-right corner of the **y-Axis Data** section. From the menu, choose **Component 2 (comp2) > Transport of Concentrated Species > Species wCH4 > tcs.c_wCH4 - Molar concentration - mol/m³**.
- 3 Click to expand the **Coloring and Style** section. From the **Width** list, choose **2**.

- 4 Click to expand the **Legends** section. Select the **Show legends** checkbox.
- 5 From the **Legends** list, choose **Evaluated**.
- 6 In the **Legend** text field, type $CH_4 \text{ eval}(t, s) \text{ s}$.

Line Graph 2

- 1 Right-click **Line Graph 1** and choose **Duplicate**.
- 2 In the **Settings** window for **Line Graph**, click **Replace Expression** in the upper-right corner of the **y-Axis Data** section. From the menu, choose **Component 2 (comp2) > Transport of Concentrated Species > Species wH2 > tcs.c_wH2 - Molar concentration - mol/m³**.
- 3 Locate the **Coloring and Style** section. Find the **Line style** subsection. From the **Line** list, choose **Dashed**.
- 4 From the **Color** list, choose **Cycle (reset)**.
- 5 Locate the **Legends** section. In the **Legend** text field, type $H_2 \text{ eval}(t, s) \text{ s}$.
- 6 In the **Concentration CH4, Porous Catalyst Bed Center** toolbar, click  **Plot**.

Porosity Distribution

- 1 In the **Model Builder** window, under **Results** click **Porosity Change 1**.
- 2 In the **Settings** window for **3D Plot Group**, type Porosity Distribution in the **Label** text field.
- 3 Click to expand the **Title** section. From the **Title type** list, choose **None**.
- 4 Locate the **Plot Settings** section. From the **View** list, choose **View 3D 2**.
- 5 Locate the **Color Legend** section. From the **Position** list, choose **Bottom**.

Surface 1

- 1 In the **Model Builder** window, expand the **Porosity Distribution** node, then click **Surface 1**.
- 2 In the **Settings** window for **Surface**, locate the **Coloring and Style** section.
- 3 From the **Color table** list, choose **Agama**.
- 4 From the **Color table transformation** list, choose **Reverse**.
- 5 In the **Porosity Distribution** toolbar, click  **Plot**.

The following modeling instructions explain how to set up the reactor overview plot.

Reactor Overview

- 1 In the **Model Builder** window, right-click **Porosity Distribution** and choose **Duplicate**.

- 2 In the **Settings** window for **3D Plot Group**, type Reactor Overview in the **Label** text field.
- 3 Locate the **Plot Settings** section. Clear the **Plot dataset edges** checkbox.
- 4 Locate the **Color Legend** section. Clear the **Show legends** checkbox.

Surface 1

- 1 In the **Model Builder** window, expand the **Reactor Overview** node, then click **Surface 1**.
- 2 In the **Settings** window for **Surface**, locate the **Coloring and Style** section.
- 3 From the **Color table type** list, choose **Discrete**.

Material Appearance 1

- 1 Right-click **Surface 1** and choose **Material Appearance**.
- 2 In the **Settings** window for **Material Appearance**, locate the **Appearance** section.
- 3 From the **Appearance** list, choose **Custom**.
- 4 From the **Material type** list, choose **Rock**.
- 5 Locate the **Color** section. Select the **Use the plot's color** checkbox.

Revolution 2D 2

In the **Model Builder** window, under **Results > Datasets** right-click **Revolution 2D 1** and choose **Duplicate**.

Selection

- 1 In the **Results** toolbar, click  **Attributes** and choose **Selection**.
- 2 In the **Settings** window for **Selection**, locate the **Geometric Entity Selection** section.
- 3 From the **Geometric entity level** list, choose **Boundary**.
- 4 Select Boundaries 10–18 only.

Surface 2

- 1 In the **Model Builder** window, under **Results > Reactor Overview** right-click **Surface 1** and choose **Duplicate**.
- 2 In the **Settings** window for **Surface**, locate the **Data** section.
- 3 From the **Dataset** list, choose **Revolution 2D 2**.
- 4 Locate the **Expression** section. In the **Expression** text field, type 1.

Material Appearance 1

- 1 In the **Model Builder** window, expand the **Surface 2** node, then click **Material Appearance 1**.
- 2 In the **Settings** window for **Material Appearance**, locate the **Appearance** section.

- 3 From the **Material type** list, choose **Steel**.
- 4 Locate the **Color** section. Clear the **Use the plot's color** checkbox.

Selection 1



- 1 In the **Model Builder** window, right-click **Surface 2** and choose **Selection**.
- 2 Click in the **Graphics** window and then press Ctrl+A to select all domains.
- 3 In the **Settings** window for **Selection**, locate the **Revolution Selection** section.
- 4 Clear the **Evaluate the start cap** checkbox.
- 5 Clear the **Evaluate the end cap** checkbox.

Add a view for the reactor overview plot, and modify it according to your preferences.

View 3D 3

In the **Model Builder** window, under **Results** right-click **Views** and choose **View 3D**.

Reactor Overview

- 1 In the **Model Builder** window, under **Results** click **Reactor Overview**.
- 2 In the **Settings** window for **3D Plot Group**, locate the **Plot Settings** section.
- 3 From the **View** list, choose **View 3D 3**.
- 4 In the **Reactor Overview** toolbar, click  **Plot**.
- 5 Click the  **Zoom Extents** button in the **Graphics** toolbar.

Delete the result nodes that are not needed.

Porosity Change, Pressure (spf), Velocity (spf)

- 1 In the **Model Builder** window, under **Results**, Ctrl-click to select **Velocity (spf)**, **Pressure (spf)**, and **Porosity Change**.
- 2 Right-click and choose **Delete**.

For future use of **Study 1**, turn off the interfaces associated with the space-dependent model.

STUDY 1

Step 1: Time Dependent

- 1 In the **Model Builder** window, expand the **Study 1** node, then click **Step 1: Time Dependent**.
- 2 In the **Settings** window for **Time Dependent**, locate the **Physics and Variables Selection** section.

3 In the **Solve for** column of the table, under **Component 2 (comp2)**, clear the checkbox for **Porosity Change (dode)**.