



Model created in COMSOL Multiphysics 6.4

Boat Reactor for Low-Pressure Chemical Vapor Deposition

Introduction

Chemical vapor deposition (CVD) is an important step in the process of manufacturing microchips. A common application is the deposition of silicon on wafers at low pressure. Low-pressure reactors such as shown in [Figure 1](#) below are used to get a high diffusivity of the gaseous species, which results in a uniform deposition thickness, because the process becomes limited by the deposition kinetics ([Ref. 1](#) and [Ref. 2](#)).

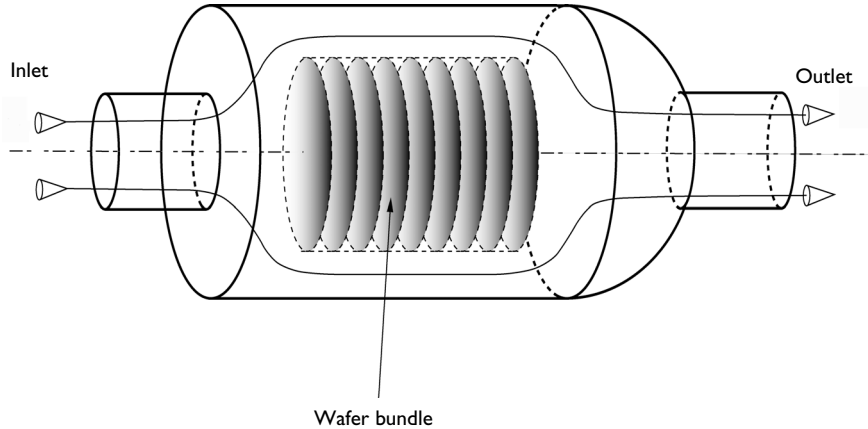

Figure 1: Schematic of a boat reactor and principle of the deposition process.

The gas, in this case silane (SiH_4), enters the reactor from the left and reacts on the wafers to form hydrogen and silicon. The remaining mixture leaves the reactor through the outlet on the right. The deposition of silicon on the wafers surface depends on the silane concentration. Further details can be found in *Elements of Chemical Reaction Engineering* by H. Scott Fogler ([Ref. 1](#)).

This example models the coupled reaction kinetics, fluid, and mass transport in a low-pressure boat reactor to describe the rate of deposition as a function of the operating conditions.

Model Definition

[Figure 2](#) shows the modeled domain of the boat reactor which is simplified as a 2D axisymmetric geometry. To further simplify the geometry and to save computational memory, the wafer bundle is modeled as a porous medium. The temperature in the reactor is assumed to be constant.

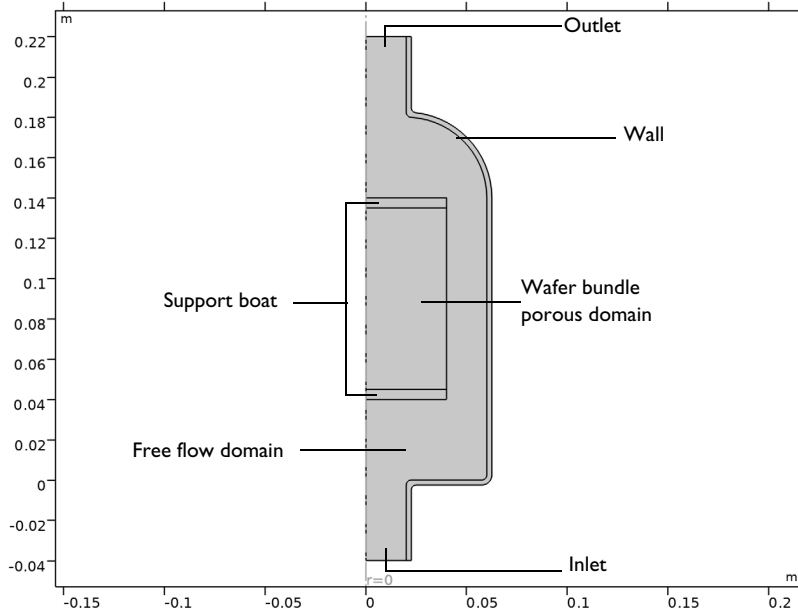

Figure 2: Model geometry including the domain and boundary labels.

The specific surface area (m^2/m^3) of the wafer bundle porous medium is calculated as the area per volume by assuming a pitch between the wafers as seen in Figure 3 below.

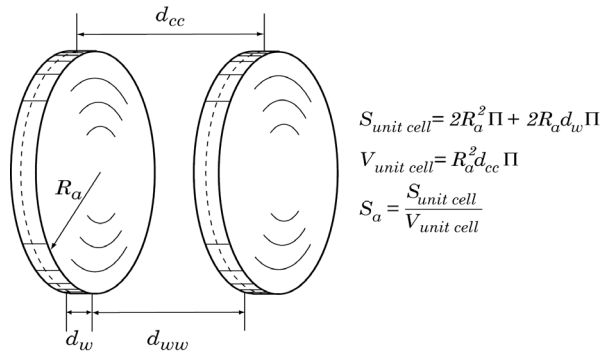

Figure 3: Specific surface area of wafer bundle calculation.

The wafer bundle porosity is the wafer volume per bundle volume:

$$\epsilon_p = \left(1 - \frac{d_w}{d_{cc}}\right)$$

CHEMISTRY

In the wafer bundle, silane gas reacts to form solid silicon which is deposited on the wafers:

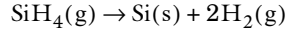

The reaction rate, R_i (mol/(m³·s)), is expressed as a first order reaction as follows:

$$R_{\text{SiH}_4} = S_a \cdot k \cdot c_{\text{SiH}_4} \quad (1)$$

where c_{SiH_4} is the local concentration (mol/m³) and k is the rate constant (m/s) which is based on experimental results (Ref. 2) as follows:

$$k = \frac{a}{1 + x_0 b P}$$

where a (m/s) and b (1/Pa) are experimental kinetic parameters (based on Ref. 2) which depend on temperature as follows:

$$a = 9.13 \cdot 10^8 \cdot T \cdot \exp\left(-\frac{3.79 \cdot 10^{-19}}{k_B T}\right)$$

$$b = 3.83 \cdot 10^9 \cdot \exp\left(-\frac{2.90 \cdot 10^{-19}}{k_B T}\right)$$

where k_B is the Boltzmann constant (J/K) and T is the reactor temperature (K).

A crucial characteristic of the reactor performance is the growth rate of the silicon layers on the wafers known as the deposition rate, Δ_{Si} (m/s), which is calculated as follows:

$$\Delta_{\text{Si}} = \frac{k c_{\text{SiH}_4} M_{\text{Si}}}{\rho_{\text{Si}}}$$

where M_{Si} is the molar mass (kg/mol) and ρ_{Si} is the density (kg/m³) of silicon.

The reacting gas species are diluted in inert nitrogen gas which is assumed to well represent the properties of the mixture.

FLUID FLOW

The flow in the reactor is modeled as laminar fluid flow. Flow inside the wafer bundle is neglected such that the reacting gas are only be transported by diffusion. This is justified since only transport in the radial direction is permitted by the physical wafers. And only dilute gas species, silane and hydrogen, experience a net transport through the wafer bundle from the deposition process. The inlet velocity is assumed to be fully developed with an average velocity and there is no slip at the reactor walls, support boat and along the wafer bundle.

MASS TRANSPORT

The diffusion, convection, and reaction of each gaseous species i in the diluted solution is described as follows:

$$\nabla \cdot (-D_i \nabla c_i) + \mathbf{u} \cdot \nabla c_i = R_i$$

where D_i is diffusion coefficient (m^2/s), c_i is the concentration (mol/m^3), \mathbf{u} is the velocity vector (m/s), and R_i is the reaction rate ($\text{mol}/(\text{m}^3 \cdot \text{s})$), as defined in [Equation 1](#). The reaction is defined only in the wafer bundle domain and therefore the reaction rate term is zero in the free flow domain. Since the gases do not diffuse through the physical wafers, the axial diffusion in the porous medium representing the wafer bundle is neglected by setting the z -component of the diffusivity matrix to zero. The inlet concentration of silane is defined from the ideal gas law at the operating conditions and there is no mass flux perpendicular to the support boat or the reactor wall boundaries.

Results and Discussion

[Figure 4](#) shows the velocity profile in the reactor, indicating that the velocity in the wafer bundle is much smaller than in the free flowing domain. [Figure 5](#) shows the concentration profile in the wafer bundle of the silane gas, which dictates the deposition rate and thickness of silicon.

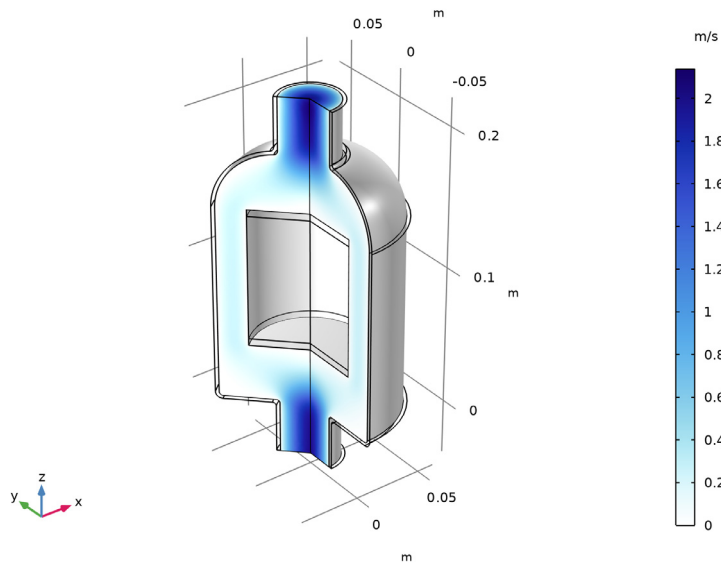

Figure 4: Velocity profile in boat reactor 600°C, 25 Pa.

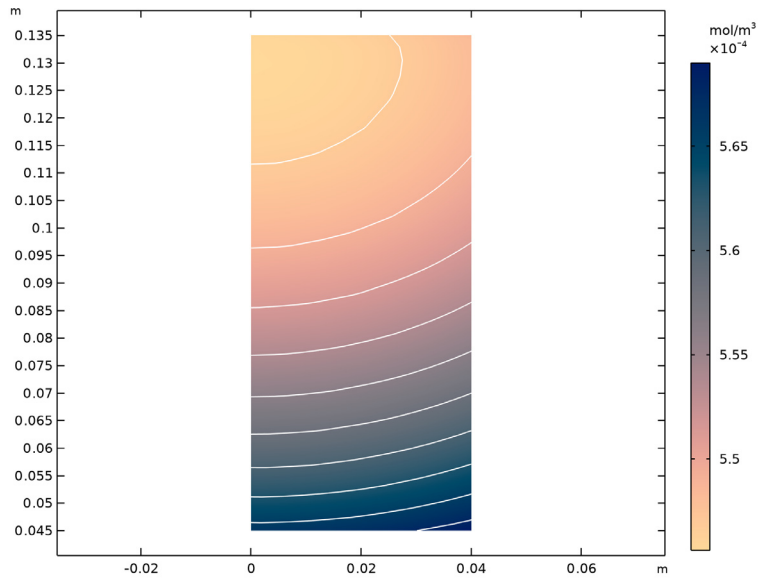

Figure 5: Silane concentration profile in wafer bundle at 600°C, 25 Pa. Lines indicate the concentration isocontours.

Figure 5 shows the concentration of the silane in the wafer bundle which is used to estimate the deposition rate of silicon on the wafers as shown in Figure 6 below. The highest concentration of silane is obtained near the reactor inlet and close to the free-fluid channel. The relative variation in silane concentration over the wafer bundle domain is 3.6%.

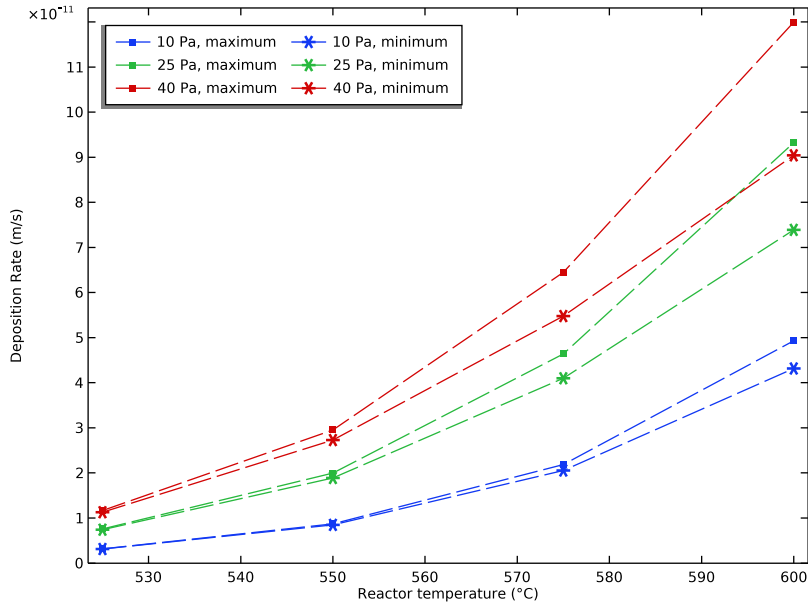

Figure 6: Variation in deposition rate with temperature, total pressure, and location in wafer bundle. The asterisks represent the minimum expected deposition rate whereas the squares represent the maximum expected deposition rate in the wafer bundle. The colors of the lines represent operating pressures.

Figure 6 shows that the variation in the deposition rate of silicon increases as the operating temperature and pressure of the reactor increases. Therefore, operating at lower pressures and higher temperatures is favorable to ensure a uniform deposition rate over the wafer bundle due to the higher diffusivity of the gaseous species.

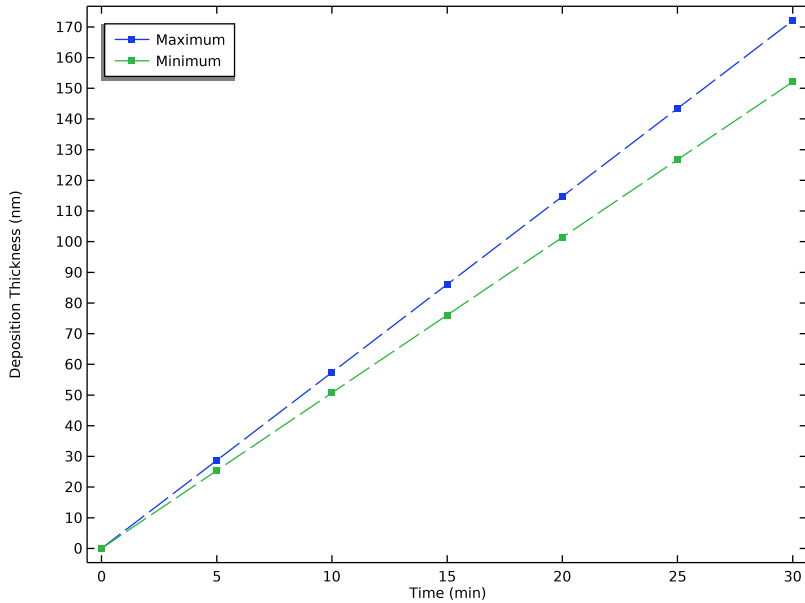

Figure 7: Deposition thickness over time at 575°C, 25 Pa.

References

1. H. Scott Fogler, *Elements of Chemical Reaction Engineering*, 3rd ed., Prentice Hall, 1999.
2. A.T. Voutsas and M.K. Hatalis, "Structure of As-Deposited LPCVD Silicon Films at Low Deposition Temperatures and Pressures," *J. Electrochem. Soc.*, vol. 139, no. 9, pp. 2659–2665, 1992.

Application Library path: Chemical_Reaction_Engineering_Module/
Reactors_with_Mass_Transfer/boat_reactor



Modeling Instructions

From the **File** menu, choose **New**.

NEW



In the **New** window, click  **Model Wizard**.

MODEL WIZARD

- 1 In the **Model Wizard** window, click  **2D Axisymmetric**.
- 2 In the **Select Physics** tree, select **Chemical Species Transport > Chemistry (chem)**.
- 3 Click **Add**.
- 4 In the **Select Physics** tree, select **Fluid Flow > Single-Phase Flow > Laminar Flow (spf)**.
- 5 Click **Add**.
- 6 In the **Select Physics** tree, select **Chemical Species Transport > Transport of Diluted Species (tds)**.
- 7 Click **Add**.
- 8 Click  **Add Concentration**.
- 9 In the **Concentrations (mol/m³)** table, enter the following settings:

cSiH4



cH2

- 10 Click  **Study**.
- 11 In the **Select Study** tree, select **General Studies > Stationary**.
- 12 Click  **Done**.

GLOBAL DEFINITIONS

Add the model parameters by importing their definitions from a data text file provided with the Application Library.

Geometric Parameters

- 1 In the **Home** toolbar, click  **Parameters** and choose **Select > Parameters I**.
- 2 In the **Settings** window for **Parameters**, type Geometric Parameters in the **Label** text field.
- 3 Locate the **Parameters** section. Click  **Load from File**.
- 4 Browse to the model's Application Libraries folder and double-click the file `boat_reactor_geometric_parameters.txt`.

Operating Parameters

- 1 In the **Home** toolbar, click  **Parameters** and choose **Add > Parameters**.

- 2 In the **Settings** window for **Parameters**, type Operating Parameters in the **Label** text field.
- 3 Locate the **Parameters** section. Click  **Load from File**.
- 4 Browse to the model's Application Libraries folder and double-click the file `boat_reactor_operating_parameters.txt`.



First, build the reactor geometry.

GEOMETRY I



Reactor

- 1 In the **Model Builder** window, under **Component 1 (comp1)** right-click **Geometry 1** and choose **Node Group**.
- 2 In the **Settings** window for **Group**, type Reactor in the **Label** text field.



Rectangle 1 (r1)

- 1 In the **Geometry** toolbar, click  **Rectangle**.
- 2 In the **Settings** window for **Rectangle**, locate the **Size and Shape** section.
- 3 In the **Width** text field, type W.
- 4 In the **Height** text field, type L.
- 5 Click  **Build Selected**.



Fillet 1 (fil1)

- 1 In the **Geometry** toolbar, click  **Fillet**.
- 2 On the object **r1**, select Point 3 only.
- 3 In the **Settings** window for **Fillet**, locate the **Radius** section.
- 4 In the **Radius** text field, type R_curve.
- 5 Click  **Build Selected**.



Rectangle 2 (r2)

- 1 In the **Geometry** toolbar, click  **Rectangle**.
- 2 In the **Settings** window for **Rectangle**, locate the **Size and Shape** section.
- 3 In the **Width** text field, type R_tube.
- 4 In the **Height** text field, type L_tube.
- 5 Locate the **Position** section. In the **z** text field, type -L_tube.
- 6 Click  **Build Selected**.



Rectangle 3 (r3)

- 1 In the **Geometry** toolbar, click  **Rectangle**.
- 2 In the **Settings** window for **Rectangle**, locate the **Size and Shape** section.
- 3 In the **Width** text field, type R_tube.
- 4 In the **Height** text field, type L_tube.
- 5 Locate the **Position** section. In the **z** text field, type L.
- 6 Click  **Build Selected**.



Union 1 (uni1)

- 1 In the **Geometry** toolbar, click  **Booleans and Partitions** and choose **Union**.
- 2 Click in the **Graphics** window and then press Ctrl+A to select all objects.
- 3 In the **Settings** window for **Union**, locate the **Union** section.
- 4 Clear the **Keep interior boundaries** checkbox.
- 5 Click  **Build Selected**.

Fillet 2 (fil2)

- 1 In the **Geometry** toolbar, click  **Fillet**.
- 2 On the object **uni1**, select Points 6, 7, and 9 only.
- 3 In the **Settings** window for **Fillet**, locate the **Radius** section.
- 4 In the **Radius** text field, type b.
- 5 Click  **Build Selected**.

Thicken 1 (thi1)

- 1 In the **Geometry** toolbar, click  **Conversions** and choose **Thicken**.
- 2 In the **Settings** window for **Thicken**, locate the **Input** section.
- 3 From the **Geometric entity level** list, choose **Boundary**.
- 4 On the object **fil2**, select Boundaries 6–13 only.
- 5 Select the **Keep input objects** checkbox.
- 6 Locate the **Options** section. From the **Offset** list, choose **Asymmetric**.
- 7 In the **Upside thickness** text field, type b.
- 8 Click  **Build Selected**.

Fillet 3 (fil3)

- 1 In the **Geometry** toolbar, click  **Fillet**.
- 2 On the object **thi1**, select Points 7 and 9 only.

3 In the **Settings** window for **Fillet**, locate the **Radius** section.

4 In the **Radius** text field, type b.

5 Click  **Build Selected**.

Wafer Bundle

1 In the **Model Builder** window, right-click **Geometry 1** and choose **Node Group**.

Next, build the wafer bundle geometry.

2 In the **Settings** window for **Group**, type Wafer Bundle in the **Label** text field.

Rectangle 4 (r4)

1 In the **Geometry** toolbar, click  **Rectangle**.

2 In the **Settings** window for **Rectangle**, locate the **Size and Shape** section.

3 In the **Width** text field, type R_w.

4 In the **Height** text field, type L_wb.

5 Locate the **Position** section. In the **z** text field, type L_space.

6 Click  **Build Selected**.

Rectangle 5 (r5)

1 In the **Geometry** toolbar, click  **Rectangle**.

2 In the **Settings** window for **Rectangle**, locate the **Size and Shape** section.

3 In the **Width** text field, type R_w.

4 In the **Height** text field, type H_sb.

5 Locate the **Position** section. In the **z** text field, type L_space.

6 Click  **Build Selected**.

Rectangle 6 (r6)

1 In the **Geometry** toolbar, click  **Rectangle**.

2 In the **Settings** window for **Rectangle**, locate the **Size and Shape** section.

3 In the **Width** text field, type R_w.

4 In the **Height** text field, type H_sb.

5 Locate the **Position** section. In the **z** text field, type L_space+L_wb-H_sb.

6 Click  **Build Selected**.

Form Union (fin)

1 In the **Model Builder** window, under **Component 1 (comp1)** > **Geometry 1** click **Form Union (fin)**.

2 In the **Settings** window for **Form Union/Assembly**, click  **Build Selected**.

3 Click the  **Zoom Extents** button in the **Graphics** toolbar.

DEFINITIONS

Next, define explicit selections with descriptive names for three domains to facilitate making selections in the physics interfaces later.

Wafer Bundle

1 In the **Definitions** toolbar, click  **Explicit**.

2 Select Domain 3 only.

3 In the **Settings** window for **Explicit**, type Wafer Bundle in the **Label** text field.

Reactor

1 In the **Definitions** toolbar, click  **Explicit**.

2 Select Domains 1 and 3 only.

3 In the **Settings** window for **Explicit**, type Reactor in the **Label** text field.

Wall

1 In the **Definitions** toolbar, click  **Explicit**.

2 Select Domains 2, 4, and 5 only.

3 In the **Settings** window for **Explicit**, type Wall in the **Label** text field.

Variables I

1 In the **Definitions** toolbar, click  **Local Variables**.

2 In the **Settings** window for **Variables**, locate the **Variables** section.

3 In the table, enter the following settings:

Name	Expression	Unit	Description
Delta_Si	$k_{rxn} * c_{SiH4} * M_{Si} / \rho_{Si}$	m/s	Deposition Rate

CHEMISTRY (CHEM)

1 In the **Model Builder** window, under **Component 1 (comp1)** click **Chemistry (chem)**.

2 In the **Settings** window for **Chemistry**, locate the **Model Input** section.

3 From the T list, choose **User defined**. In the associated text field, type T_r .

4 From the p list, choose **User defined**. In the associated text field, type p_{tot} .

Reaction 1

- 1 In the **Physics** toolbar, click  **Domains** and choose **Reaction**.
- 2 In the **Settings** window for **Reaction**, locate the **Reaction Formula** section.
- 3 In the **Formula** text field, type $\text{SiH}_4 \Rightarrow \text{Si}(s) + 2 \text{H}_2$.
- 4 Click **Apply**.
- 5 Locate the **Rate Constants** section. In the k^f text field, type $k_{\text{rxn}} \cdot S_a$.

Species 1

- 1 In the **Physics** toolbar, click  **Domains** and choose **Species**.
- 2 In the **Settings** window for **Species**, locate the **Name** section.
- 3 In the text field, type N_2 .
- 4 Locate the **Type** section. From the list, choose **Solvent**.
- 5 In the **Model Builder** window, click **Chemistry (chem)**.
- 6 In the **Settings** window for **Chemistry**, locate the **Species Matching** section.
- 7 Find the **Bulk species** subsection. From the **Species solved for** list, choose **Transport of Diluted Species**.
- 8 In the table, enter the following settings:

Species	Type	Molar concentration	Value (mol/m ³)
H2	Variable	cH2	Solved for
N2	Solvent	User defined	c_N2
SiH4	Variable	cSiH4	Solved for

- 9 Find the **Solid species** subsection. In the table, enter the following settings:

Species	Species concentration type	Molar concentration (mol/m ³)
Si(s)	Variable	0

LAMINAR FLOW (SPF)

- 1 In the **Model Builder** window, under **Component 1 (comp1)** click **Laminar Flow (spf)**.
- 2 Select Domain 1 only.
- 3 In the **Settings** window for **Laminar Flow**, locate the **Physical Model** section.
- 4 In the p_{ref} text field, type p_{tot} .
- 5 In the T_{ref} text field, type T_r .

Fluid Properties 1

- 1 In the **Model Builder** window, under **Component 1 (comp1) > Laminar Flow (spf)** click **Fluid Properties 1**.
- 2 In the **Settings** window for **Fluid Properties**, locate the **Fluid Properties** section.
- 3 From the ρ list, choose **Density (chem)**.
- 4 From the μ list, choose **Dynamic viscosity (chem)**.

Inlet 1

- 1 In the **Physics** toolbar, click  **Boundaries** and choose **Inlet**.
- 2 Select Boundary 2 only.
- 3 In the **Settings** window for **Inlet**, locate the **Boundary Condition** section.
- 4 From the list, choose **Fully developed flow**.
- 5 Locate the **Fully Developed Flow** section. In the U_{av} text field, type v_0 .

Outlet 1

- 1 In the **Physics** toolbar, click  **Boundaries** and choose **Outlet**.
- 2 Select Boundary 13 only.

TRANSPORT OF DILUTED SPECIES (TDS)

- 1 In the **Model Builder** window, under **Component 1 (comp1)** click **Transport of Diluted Species (tds)**.
- 2 In the **Settings** window for **Transport of Diluted Species**, locate the **Domain Selection** section.
- 3 From the **Selection** list, choose **Reactor**.
- 4 Locate the **Transport Mechanisms** section. Select the **Mass transfer in porous media** checkbox.

Fluid 1

- 1 In the **Model Builder** window, under **Component 1 (comp1) > Transport of Diluted Species (tds)** click **Fluid 1**.
- 2 In the **Settings** window for **Fluid**, locate the **Model Input** section.
- 3 From the T list, choose **User defined**. In the associated text field, type T_r .
- 4 Locate the **Convection** section. From the u list, choose **Velocity field (spf)**.
- 5 Locate the **Diffusion** section. From the **Source** list, choose **Chemistry**.
- 6 From the D_{cSiH4} list, choose **Diffusion coefficient , SiH4 in N2 (solvent) (chem)**.
- 7 From the D_{cH2} list, choose **Diffusion coefficient , H2 in N2 (solvent) (chem)**.

Reactions 1

- 1 In the **Physics** toolbar, click  **Domains** and choose **Reactions**.
- 2 In the **Settings** window for **Reactions**, locate the **Domain Selection** section.
- 3 From the **Selection** list, choose **Wafer Bundle**.
- 4 Locate the **Reaction Rates** section. From the **Chemistry** list, choose **Chemistry (chem)**.
- 5 Locate the **Reacting Volume** section. From the list, choose **Pore volume**.

Inflow 1

- 1 In the **Physics** toolbar, click  **Boundaries** and choose **Inflow**.
- 2 Select Boundary 2 only.
- 3 In the **Settings** window for **Inflow**, locate the **Concentration** section.
- 4 In the $c_{0,cSiH4}$ text field, type c_{SiH4} .

Outflow 1

- 1 In the **Physics** toolbar, click  **Boundaries** and choose **Outflow**.
- 2 Select Boundary 13 only.

Porous Medium 1

- 1 In the **Physics** toolbar, click  **Domains** and choose **Porous Medium**.
- 2 In the **Settings** window for **Porous Medium**, locate the **Domain Selection** section.
- 3 From the **Selection** list, choose **Wafer Bundle**.

Fluid 1

- 1 In the **Model Builder** window, click **Fluid 1**.
- 2 In the **Settings** window for **Fluid**, locate the **Model Input** section.
- 3 From the T list, choose **User defined**. In the associated text field, type T_r .
- 4 Locate the **Convection** section. From the u list, choose **Velocity field (spf)**.
- 5 Locate the **Diffusion** section. From the **Source** list, choose **Chemistry**.
- 6 From the list, choose **Diagonal**.
- 7 Specify the D_{cSiH4} matrix as

chem.D_SiH4	0
0	0

- 8 From the list, choose **Diagonal**.

9 Specify the D_{cH_2} matrix as

chem.D_H2	0
0	0

10 From the **Effective diffusivity model** list, choose **No correction**.

Porous Matrix 1

- 1 In the **Model Builder** window, click **Porous Matrix 1**.
- 2 In the **Settings** window for **Porous Matrix**, locate the **Matrix Properties** section.
- 3 From the ϵ_p list, choose **User defined**. In the associated text field, type e_p .

MULTIPHYSICS

Reacting Flow, Diluted Species 1 (rfd1)

In the **Physics** toolbar, click  **Multiphysics Couplings** and choose **Domain > Reacting Flow, Diluted Species**.

MESH 1

In the **Model Builder** window, under **Component 1 (comp1)** right-click **Mesh 1** and choose **Build All**.

STUDY 1

Parametric Sweep

- 1 In the **Study** toolbar, click  **Parametric Sweep**.
- 2 In the **Settings** window for **Parametric Sweep**, locate the **Study Settings** section.
- 3 From the **Sweep type** list, choose **All combinations**.
- 4 Click **+ Add**.
- 5 Click **+ Add**.
- 6 In the table, enter the following settings:

Parameter name	Parameter value list	Parameter unit
T_r (Reactor temperature)	range (525, 25, 600)	degC
p_tot (Total system pressure)	range (10, 15, 40)	Pa

- 7 In the **Study** toolbar, click  **Compute**.

RESULTS

Velocity (spf)

- 1 In the **Settings** window for **2D Plot Group**, locate the **Data** section.
- 2 From the **Parameter value (p_tot (Pa))** list, choose **25**.
- 3 Click to expand the **Title** section. From the **Title type** list, choose **None**.
- 4 Locate the **Color Legend** section. Select the **Show units** checkbox.

Surface

- 1 In the **Model Builder** window, expand the **Velocity (spf)** node, then click **Surface**.
- 2 In the **Settings** window for **Surface**, locate the **Coloring and Style** section.
- 3 From the **Color table** list, choose **Kyanite**.

Pressure (spf)

- 1 In the **Model Builder** window, under **Results** click **Pressure (spf)**.
- 2 In the **Settings** window for **2D Plot Group**, locate the **Data** section.
- 3 From the **Parameter value (p_tot (Pa))** list, choose **25**.
- 4 Locate the **Title** section. From the **Title type** list, choose **None**.
- 5 Locate the **Color Legend** section. Select the **Show units** checkbox.

Surface 1

- 1 In the **Model Builder** window, expand the **Pressure (spf)** node, then click **Surface 1**.
- 2 In the **Settings** window for **Surface**, locate the **Coloring and Style** section.
- 3 From the **Color table** list, choose **Kyanite**.

Velocity, 3D (spf)

- 1 In the **Model Builder** window, under **Results** click **Velocity, 3D (spf)**.
- 2 In the **Settings** window for **3D Plot Group**, locate the **Data** section.
- 3 From the **Parameter value (p_tot (Pa))** list, choose **25**.
- 4 Click to expand the **Title** section. From the **Title type** list, choose **None**.
- 5 Locate the **Color Legend** section. Select the **Show units** checkbox.

Surface

- 1 In the **Model Builder** window, expand the **Velocity, 3D (spf)** node, then click **Surface**.
- 2 In the **Settings** window for **Surface**, locate the **Coloring and Style** section.
- 3 From the **Color table** list, choose **Kyanite**.
- 4 Click the  **Zoom Extents** button in the **Graphics** toolbar.

Concentration, SiH4 (tds)

- 1 In the **Model Builder** window, under **Results** click **Concentration, SiH4 (tds)**.
- 2 In the **Settings** window for **2D Plot Group**, locate the **Data** section.
- 3 From the **Parameter value (p_tot (Pa))** list, choose **25**.
- 4 Locate the **Title** section. From the **Title type** list, choose **None**.
- 5 Locate the **Color Legend** section. Select the **Show units** checkbox.

Surface 1

- 1 In the **Model Builder** window, expand the **Concentration, SiH4 (tds)** node, then click **Surface 1**.
- 2 In the **Settings** window for **Surface**, locate the **Coloring and Style** section.
- 3 From the **Color table** list, choose **Agama**.
- 4 Click the  **Zoom Extents** button in the **Graphics** toolbar.

Concentration, SiH4 (tds) 1

- 1 In the **Model Builder** window, right-click **Concentration, SiH4 (tds)** and choose **Duplicate**.
- 2 Drag and drop **Concentration, SiH4 (tds) 1** below **Concentration, SiH4 (tds)**.

Surface 1

In the **Model Builder** window, expand the **Concentration, SiH4 (tds) 1** node, then click **Surface 1**.

Selection 1

- 1 In the **Concentration, SiH4 (tds) 1** toolbar, click  **Selection**.
- 2 In the **Settings** window for **Selection**, locate the **Selection** section.
- 3 From the **Selection** list, choose **Wafer Bundle**.

Arrow Surface 1

In the **Model Builder** window, under **Results > Concentration, SiH4 (tds) 1** right-click **Arrow Surface 1** and choose **Disable**.

Surface 1

In the **Model Builder** window, click **Surface 1**.

Concentration, SiH4 (tds) 1

In the **Concentration, SiH4 (tds) 1** toolbar, click  **Contour**.

Contour 1



- 1 In the **Settings** window for **Contour**, locate the **Expression** section.

- 2 In the **Expression** text field, type `cSiH4`.
- 3 Click to expand the **Title** section. From the **Title type** list, choose **None**.
- 4 Locate the **Levels** section. In the **Total levels** text field, type 10.
- 5 Locate the **Coloring and Style** section. From the **Coloring** list, choose **Uniform**.
- 6 From the **Color** list, choose **White**.
- 7 Clear the **Color legend** checkbox.

Selection 1

- 1 In the **Concentration, SiH4 (tds) 1** toolbar, click  **Selection**.
- 2 In the **Settings** window for **Selection**, locate the **Selection** section.
- 3 From the **Selection** list, choose **Wafer Bundle**.

Concentration, SiH4 (tds) 1

- 1 In the **Model Builder** window, under **Results** click **Concentration, SiH4 (tds) 1**.
- 2 In the **Settings** window for **2D Plot Group**, locate the **Plot Settings** section.
- 3 Clear the **Plot dataset edges** checkbox.
- 4 In the **Concentration, SiH4 (tds) 1** toolbar, click  **Plot**.
- 5 Click the  **Zoom Extents** button in the **Graphics** toolbar.

Concentration, SiH4, 3D (tds)

- 1 In the **Model Builder** window, click **Concentration, SiH4, 3D (tds)**.
- 2 In the **Settings** window for **3D Plot Group**, locate the **Data** section.
- 3 From the **Parameter value (p_tot (Pa))** list, choose **25**.
- 4 Locate the **Title** section. From the **Title type** list, choose **None**.
- 5 Locate the **Color Legend** section. Select the **Show units** checkbox.

Surface 1

- 1 In the **Model Builder** window, expand the **Concentration, SiH4, 3D (tds)** node, then click **Surface 1**.
- 2 In the **Settings** window for **Surface**, locate the **Coloring and Style** section.
- 3 From the **Color table** list, choose **Agama**.

Concentration, H2 (tds)

- 1 In the **Model Builder** window, under **Results** click **Concentration, H2 (tds)**.
- 2 In the **Settings** window for **2D Plot Group**, locate the **Data** section.
- 3 From the **Parameter value (p_tot (Pa))** list, choose **25**.

- 4 Locate the **Title** section. From the **Title type** list, choose **None**.
- 5 Locate the **Color Legend** section. Select the **Show units** checkbox.

Surface 1

- 1 In the **Model Builder** window, expand the **Concentration, H2 (tds)** node, then click **Surface 1**.
- 2 In the **Settings** window for **Surface**, locate the **Coloring and Style** section.
- 3 From the **Color table** list, choose **Caissara**.

Concentration, H2, 3D (tds)



- 1 In the **Model Builder** window, under **Results** click **Concentration, H2, 3D (tds)**.
- 2 In the **Settings** window for **3D Plot Group**, locate the **Data** section.
- 3 From the **Parameter value (p_tot (Pa))** list, choose **25**.
- 4 Locate the **Title** section. From the **Title type** list, choose **None**.
- 5 Locate the **Color Legend** section. Select the **Show units** checkbox.

Surface 1

- 1 In the **Model Builder** window, expand the **Concentration, H2, 3D (tds)** node, then click **Surface 1**.
- 2 In the **Settings** window for **Surface**, locate the **Coloring and Style** section.
- 3 From the **Color table** list, choose **Caissara**.

Define a cut point at the center of the wafer bundle to study the deposition rate of silicon at this point as a function of operating conditions.

Midpoint



- 1 In the **Results** toolbar, click  **Cut Point 2D**.
- 2 In the **Settings** window for **Cut Point 2D**, locate the **Point Data** section.
- 3 In the **r** text field, type 0.
- 4 In the **z** text field, type $L/2$.
- 5 In the **Label** text field, type Midpoint.
- 6 Click  **Plot**.

Deposition rate vs T, P at midpoint

- 1 In the **Results** toolbar, click  **ID Plot Group**.
- 2 In the **Settings** window for **ID Plot Group**, type Deposition rate vs T, P at midpoint in the **Label** text field.

- 3 Locate the **Data** section. From the **Dataset** list, choose **Midpoint**.
- 4 Click to expand the **Title** section. From the **Title type** list, choose **None**.
- 5 Locate the **Grid** section. Clear the **Show grid** checkbox.
- 6 Locate the **Legend** section. From the **Position** list, choose **Upper left**.

Point Graph 1

- 1 In the **Deposition rate vs T, P at midpoint** toolbar, click  **Point Graph**.
- 2 In the **Settings** window for **Point Graph**, locate the **y-Axis Data** section.
- 3 In the **Expression** text field, type `Delta_Si`.
- 4 Select the **Description** checkbox.
- 5 Locate the **x-Axis Data** section. From the **Axis source data** list, choose **T_r**.
- 6 From the **Parameter** list, choose **Expression**.
- 7 In the **Expression** text field, type `T_r`.
- 8 From the **Unit** list, choose **°C**.
- 9 Select the **Description** checkbox.
- 10 Click to expand the **Coloring and Style** section. Find the **Line style** subsection. From the **Line** list, choose **Dashed**.
- 11 Find the **Line markers** subsection. From the **Marker** list, choose **Point**.
- 12 Click to expand the **Legends** section. Select the **Show legends** checkbox.
- 13 Find the **Include** subsection. Clear the **Point** checkbox.
- 14 Clear the **Solution** checkbox.
- 15 Find the **Prefix and suffix** subsection. In the **Prefix** text field, type `eval(p_tot, Pa) Pa`.
- 16 In the **Deposition rate vs T, P at midpoint** toolbar, click  **Plot**.

Follow these instructions to generate [Figure 6](#) in the model documentation.

Maximum 1

In the **Results** toolbar, click  **More Datasets** and choose **Evaluation > Maximum**.

Minimum 1

In the **Results** toolbar, click  **More Datasets** and choose **Evaluation > Minimum**.

Variation in deposition rate

- 1 In the **Results** toolbar, click  **ID Plot Group**.
- 2 In the **Settings** window for **ID Plot Group**, type **Variation in deposition rate** in the **Label** text field.

- 3 Locate the **Data** section. From the **Dataset** list, choose **Maximum I**.
- 4 Locate the **Title** section. From the **Title type** list, choose **None**.
- 5 Locate the **Grid** section. Clear the **Show grid** checkbox.
- 6 Locate the **Legend** section. From the **Layout** list, choose **Inside graph axis area**.
- 7 From the **Position** list, choose **Upper left**.
- 8 In the **Number of columns** text field, type 2.
- 9 In the **Maximum relative width** text field, type 1.

Maximum

- 1 In the **Variation in deposition rate** toolbar, click  **Point Graph**.
- 2 In the **Settings** window for **Point Graph**, type Maximum in the **Label** text field.
- 3 Locate the **Data** section. From the **Dataset** list, choose **Maximum I**.
- 4 Locate the **y-Axis Data** section. Select the **Description** checkbox.
- 5 In the **Expression** text field, type Delta_Si.
- 6 In the **Description** text field, type Deposition Rate.
- 7 Locate the **x-Axis Data** section. From the **Axis source data** list, choose **T_r**.
- 8 From the **Parameter** list, choose **Expression**.
- 9 In the **Expression** text field, type T_r.
- 10 From the **Unit** list, choose °C.
- 11 Locate the **Coloring and Style** section. Find the **Line style** subsection. From the **Line** list, choose **Dashed**.
- 12 Find the **Line markers** subsection. From the **Marker** list, choose **Point**.
- 13 Locate the **Legends** section. Select the **Show legends** checkbox.
- 14 Find the **Include** subsection. Clear the **Point** checkbox.
- 15 Clear the **Solution** checkbox.
- 16 Find the **Prefix and suffix** subsection. In the **Prefix** text field, type eval(p_tot, Pa) Pa.
- 17 In the **Suffix** text field, type , maximum.

Variation in deposition rate

In the **Variation in deposition rate** toolbar, click  **Point Graph**.

Minimum

- 1 In the **Settings** window for **Point Graph**, type Minimum in the **Label** text field.
- 2 Locate the **Data** section. From the **Dataset** list, choose **Minimum I**.

- 3 Locate the **y-Axis Data** section. In the **Expression** text field, type `Delta_Si`.
- 4 Select the **Description** checkbox.
- 5 Locate the **x-Axis Data** section. From the **Axis source data** list, choose **T_r**.
- 6 From the **Parameter** list, choose **Expression**.
- 7 In the **Expression** text field, type `T_r`.
- 8 From the **Unit** list, choose **°C**.
- 9 Locate the **Coloring and Style** section. Find the **Line style** subsection. From the **Line** list, choose **Dashed**.
- 10 Find the **Line markers** subsection. From the **Marker** list, choose **Asterisk**.
- 11 Locate the **Legends** section. Select the **Show legends** checkbox.
- 12 Find the **Include** subsection. Clear the **Point** checkbox.
- 13 Clear the **Solution** checkbox.
- 14 Find the **Prefix and suffix** subsection. In the **Prefix** text field, type `eval(p_tot, Pa) Pa`.
- 15 In the **Suffix** text field, type `, minimum`.
- 16 Locate the **Coloring and Style** section. From the **Color** list, choose **Cycle (reset)**.
- 17 In the **Variation in deposition rate** toolbar, click  **Plot**.

The time-dependency needs to be introduced in order to study the deposition thickness. Since the system reaches steady state almost immediately, save computational memory by using an empty time-dependent study. The values of the dependent variables not solved for in this study are taken from the initial stationary study for a specific parameter sweep combination of interest.

ADD STUDY

- 1 In the **Study** toolbar, click  **Add Study** to open the **Add Study** window.
- 2 Go to the **Add Study** window.
- 3 Find the **Studies** subsection. In the **Select Study** tree, select **General Studies > Time Dependent**.
- 4 Click the **Add Study** button in the window toolbar.

STUDY 2

Step 1: Time Dependent



- 1 In the **Settings** window for **Time Dependent**, locate the **Study Settings** section.
- 2 From the **Time unit** list, choose **min**.

- 3 In the **Output times** text field, type range (0,5,30).
- 4 Locate the **Physics and Variables Selection** section. In the **Solve for** column of the table, clear the checkbox for **Component 1 (comp1)**.
- 5 Click to expand the **Values of Dependent Variables** section. Find the **Values of variables not solved for** subsection. From the **Settings** list, choose **User controlled**.
- 6 From the **Method** list, choose **Solution**.
- 7 From the **Study** list, choose **Study 1, Stationary**.
- 8 From the **Parameter value (T_r (degC),p_tot (Pa))** list, choose **8: T_r=575 degC, p_tot=25 Pa**.
- 9 In the **Study** toolbar, click  **Compute**.

RESULTS

Define another cut point at the center of the wafer bundle for the time-dependent study results to study the deposition thickness of silicon.

Midpoint, study 2

- 1 In the **Results** toolbar, click  **Cut Point 2D**.
- 2 In the **Settings** window for **Cut Point 2D**, type Midpoint, study 2 in the **Label** text field.
- 3 Locate the **Data** section. From the **Dataset** list, choose **Study 2/Solution 2 (sol2)**.
- 4 Locate the **Point Data** section. In the **r** text field, type 0.
- 5 In the **z** text field, type L/2.
- 6 Click  **Plot**.

Thickness over time at midpoint

- 1 In the **Results** toolbar, click  **ID Plot Group**.
- 2 In the **Settings** window for **ID Plot Group**, type Thickness over time at midpoint in the **Label** text field.
- 3 Locate the **Data** section. From the **Dataset** list, choose **Midpoint, study 2**.
- 4 Locate the **Title** section. From the **Title type** list, choose **None**.
- 5 Locate the **Grid** section. Clear the **Show grid** checkbox.

Point Graph 1

- 1 In the **Thickness over time at midpoint** toolbar, click  **Point Graph**.
- 2 In the **Settings** window for **Point Graph**, locate the **y-Axis Data** section.

- 3 In the **Expression** text field, type $\Delta_{Si} * t$.
- 4 From the **Unit** list, choose **nm**.
- 5 Select the **Description** checkbox. In the associated text field, type **Deposition Thickness**.
- 6 Locate the **Coloring and Style** section. Find the **Line style** subsection. From the **Line** list, choose **Dashed**.
- 7 Find the **Line markers** subsection. From the **Marker** list, choose **Point**.
- 8 In the **Thickness over time at midpoint** toolbar, click  **Plot**.

Follow these instructions to generate [Figure 7](#) in the model documentation.

Maximum 2

- 1 In the **Results** toolbar, click  **More Datasets** and choose **Evaluation > Maximum**.
- 2 In the **Settings** window for **Maximum**, locate the **Data** section.
- 3 From the **Dataset** list, choose **Study 2/Solution 2 (sol2)**.

Minimum 2

- 1 In the **Results** toolbar, click  **More Datasets** and choose **Evaluation > Minimum**.
- 2 In the **Settings** window for **Minimum**, locate the **Data** section.
- 3 From the **Dataset** list, choose **Study 2/Solution 2 (sol2)**.

Variation in thickness

- 1 In the **Results** toolbar, click  **ID Plot Group**.
- 2 In the **Settings** window for **ID Plot Group**, type **Variation in thickness** in the **Label** text field.
- 3 Locate the **Data** section. From the **Dataset** list, choose **Maximum 2**.
- 4 Locate the **Title** section. From the **Title type** list, choose **None**.
- 5 Locate the **Grid** section. Clear the **Show grid** checkbox.
- 6 Locate the **Legend** section. From the **Position** list, choose **Upper left**.

Maximum

- 1 In the **Variation in thickness** toolbar, click  **Point Graph**.
- 2 In the **Settings** window for **Point Graph**, type **Maximum** in the **Label** text field.
- 3 Locate the **Data** section. From the **Dataset** list, choose **Maximum 2**.
- 4 Locate the **y-Axis Data** section. In the **Expression** text field, type $\Delta_{Si} * t$.
- 5 From the **Unit** list, choose **nm**.

- 6 Select the **Description** checkbox. In the associated text field, type Deposition Thickness.
- 7 Locate the **Coloring and Style** section. Find the **Line style** subsection. From the **Line** list, choose **Dashed**.
- 8 Find the **Line markers** subsection. From the **Marker** list, choose **Point**.
- 9 Locate the **Legends** section. Select the **Show legends** checkbox.
- 10 Find the **Include** subsection. Clear the **Point** checkbox.
- 11 Clear the **Solution** checkbox.
- 12 Select the **Label** checkbox.

Variation in thickness

In the **Variation in thickness** toolbar, click  **Point Graph**.

Minimum

- 1 In the **Settings** window for **Point Graph**, type Minimum in the **Label** text field.
- 2 Locate the **Data** section. From the **Dataset** list, choose **Minimum 2**.
- 3 Locate the **y-Axis Data** section. In the **Expression** text field, type $\Delta_{Si} \cdot t$.
- 4 From the **Unit** list, choose **nm**.
- 5 Select the **Description** checkbox. In the associated text field, type Deposition Thickness.
- 6 Locate the **Coloring and Style** section. Find the **Line style** subsection. From the **Line** list, choose **Dashed**.
- 7 Find the **Line markers** subsection. From the **Marker** list, choose **Point**.
- 8 Locate the **Legends** section. Select the **Show legends** checkbox.
- 9 Find the **Include** subsection. Clear the **Point** checkbox.
- 10 Clear the **Solution** checkbox.
- 11 Select the **Label** checkbox.

Variation in thickness

- 1 In the **Model Builder** window, click **Variation in thickness**.
- 2 In the **Variation in thickness** toolbar, click  **Plot**.

Revolution 2D 2

- 1 In the **Results** toolbar, click  **More Datasets** and choose **Revolution 2D**.
- 2 In the **Settings** window for **Revolution 2D**, click to expand the **Revolution Layers** section.
- 3 In the **Start angle** text field, type -90.

4 In the **Revolution angle** text field, type 225.

5 Click  **Plot**.

Selection

1 In the **Results** toolbar, click  **Attributes** and choose **Selection**.

2 In the **Settings** window for **Selection**, locate the **Geometric Entity Selection** section.

3 From the **Geometric entity level** list, choose **Domain**.

4 From the **Selection** list, choose **Wafer Bundle**.

Revolution 2D 3

1 In the **Results** toolbar, click  **More Datasets** and choose **Revolution 2D**.

2 In the **Settings** window for **Revolution 2D**, locate the **Revolution Layers** section.

3 In the **Start angle** text field, type -90.

4 In the **Revolution angle** text field, type 225.

Selection

1 In the **Results** toolbar, click  **Attributes** and choose **Selection**.

2 In the **Settings** window for **Selection**, locate the **Geometric Entity Selection** section.

3 From the **Geometric entity level** list, choose **Domain**.

4 From the **Selection** list, choose **Wall**.

Revolution 2D 3

1 In the **Model Builder** window, click **Revolution 2D 3**.

2 In the **Settings** window for **Revolution 2D**, click  **Plot**.

3D Boat Reactor

1 In the **Results** toolbar, click  **3D Plot Group**.

2 In the **Settings** window for **3D Plot Group**, type 3D Boat Reactor in the **Label** text field.

3 Locate the **Data** section. From the **Parameter value (p_tot (Pa))** list, choose **25**.

4 Locate the **Title** section. From the **Title type** list, choose **None**.

5 Locate the **Plot Settings** section. Clear the **Plot dataset edges** checkbox.

6 Locate the **Color Legend** section. Clear the **Show legends** checkbox.

Wafer bundle

1 In the **3D Boat Reactor** toolbar, click  **Volume**.

2 In the **Settings** window for **Volume**, type Wafer bundle in the **Label** text field.

3 Locate the **Data** section. From the **Dataset** list, choose **Revolution 2D 2**.

- 4 From the **Solution parameters** list, choose **From parent**.
- 5 Locate the **Expression** section. In the **Expression** text field, type cSiH_4 .
- 6 Locate the **Coloring and Style** section. From the **Color table** list, choose **Garnet**.

3D Boat Reactor

In the **3D Boat Reactor** toolbar, click  **Volume**.

Walls

- 1 In the **Settings** window for **Volume**, locate the **Data** section.
- 2 From the **Dataset** list, choose **Revolution 2D 3**.
- 3 In the **Label** text field, type Walls.
- 4 Locate the **Data** section. From the **Solution parameters** list, choose **From parent**.
- 5 Locate the **Expression** section. In the **Expression** text field, type 1.

Material Appearance 1

- 1 In the **3D Boat Reactor** toolbar, click  **Material Appearance**.
- 2 In the **Settings** window for **Material Appearance**, locate the **Appearance** section.
- 3 From the **Appearance** list, choose **Custom**.
- 4 From the **Material type** list, choose **Steel**.

3D Boat Reactor

In the **3D Boat Reactor** toolbar, click  **Streamline**.

Flow





- 1 In the **Settings** window for **Streamline**, type Flow in the **Label** text field.
- 2 Locate the **Streamline Positioning** section. From the **Positioning** list, choose **Uniform density**.
- 3 In the **Density level** text field, type 9.
- 4 Locate the **Coloring and Style** section. Find the **Line style** subsection. From the **Type** list, choose **Ribbon**.

Color Expression 1

- 1 In the **3D Boat Reactor** toolbar, click  **Color Expression**.
- 2 In the **Settings** window for **Color Expression**, locate the **Coloring and Style** section.
- 3 From the **Color table** list, choose **Kyanite**.

3D Boat Reactor

- 1 Click the  **Show Grid** button in the **Graphics** toolbar.

- 2 Click the  **Go to Default View** button in the **Graphics** toolbar.
- 3 In the **Model Builder** window, under **Results** click **3D Boat Reactor**.
- 4 In the **3D Boat Reactor** toolbar, click  **Plot**.
- 5 Click the  **Zoom Extents** button in the **Graphics** toolbar.
- 6 In the **Settings** window for **3D Plot Group**, in the **Graphics** window toolbar, click ▼ next to  **Scene Light**, then choose **Outdoor**.