



Model created in COMSOL Multiphysics 6.4

# Solar Panel in Periodic Flow Template

## Introduction

---

This model is a template MPH file containing the geometry and mesh used by the *Solar Panel in Periodic Flow* model.

---

**Application Library path:** CFD\_Module/Fluid-Structure\_Interaction/  
solar\_panel\_geom

---

## Modeling Instructions



---

From the **File** menu, choose **New**.

### NEW

In the **New** window, click  **Model Wizard**.

### MODEL WIZARD

- 1 In the **Model Wizard** window, click  **3D**.
- 2 In the **Select Physics** tree, select **Fluid Flow > Single-Phase Flow > Turbulent Flow > Turbulent Flow, k- $\epsilon$  (spf)**.
- 3 Click **Add**.
- 4 Click  **Study**.
- 5 In the **Select Study** tree, select **General Studies > Stationary**.
- 6 Click  **Done**.

### GLOBAL DEFINITIONS

#### Parameters 1



- 1 In the **Model Builder** window, under **Global Definitions** click **Parameters 1**.
- 2 In the **Settings** window for **Parameters**, locate the **Parameters** section.
- 3 In the table, enter the following settings:

Name	Expression	Value	Description
Utop	25[m/s]	25 m/s	Velocity at top, Couette flow
yLen	6[m]	6 m	Streamwise box length
yEnd	4[m]	4 m	Streamwise box end point

## GEOMETRY I

Import the geometry of the solar panel.

### *Import I (impI)*



- 1 In the **Model Builder** window, expand the **Component 1 (comp1) > Geometry 1** node.
- 2 Right-click **Geometry 1** and choose **Import**.
- 3 In the **Settings** window for **Import**, locate the **Source** section.
- 4 Click  **Browse**.
- 5 Browse to the model's Application Libraries folder and double-click the file `solar_panel_geom_solid.mphbin`.
- 6 Click  **Import**.

Inscribe the solar panel in what will later become the fluid domains.

### *Block 1 (blk1)*

- 1 In the **Geometry** toolbar, click  **Block**.
- 2 In the **Settings** window for **Block**, locate the **Size and Shape** section.
- 3 In the **Width** text field, type 3[m].
- 4 In the **Depth** text field, type yLen.
- 5 In the **Height** text field, type 6[m].
- 6 Locate the **Position** section. In the **y** text field, type -2[m].

### *Difference 1 (dif1)*

- 1 In the **Geometry** toolbar, click  **Booleans and Partitions** and choose **Difference**.
- 2 Select the object **blk1** only.
- 3 In the **Settings** window for **Difference**, locate the **Difference** section.
- 4 Click to select the  **Activate Selection** toggle button for **Objects to subtract**.
- 5 Select the object **imp1** only.
- 6 Select the **Keep objects to subtract** checkbox.

Delete the parts of the structure that will not be simulated.

### *Delete Entities 1 (del1)*

- 1 Right-click **Geometry 1** and choose **Delete Entities**.
- 2 In the **Settings** window for **Delete Entities**, locate the **Entities or Objects to Delete** section.
- 3 From the **Geometric entity level** list, choose **Domain**.

- 4 On the object **dif1**, select Domains 2 and 3 only.
- 5 On the object **imp1**, select Domains 4 and 5 only.

#### *Union 1 (uni1)*

- 1 In the **Geometry** toolbar, click  **Booleans and Partitions** and choose **Union**.
- 2 Click in the **Graphics** window and then press Ctrl+A to select both objects.

Create a fluid domain tall enough to capture the boundary layer.

#### *Extrude 1 (ext1)*

- 1 In the **Geometry** toolbar, click  **Extrude**.
- 2 On the object **uni1**, select Boundary 4 only.
- 3 In the **Settings** window for **Extrude**, locate the **Distances** section.
- 4 In the table, enter the following settings:

<b>Distances (m)</b>
19[m]

Next, partition the geometry in order to facilitate the creation of a mapped mesh.

#### *Work Plane 1 (wp1)*

- 1 In the **Geometry** toolbar, click  **Work Plane**.
- 2 In the **Settings** window for **Work Plane**, locate the **Plane Definition** section.
- 3 From the **Plane type** list, choose **Face parallel**.
- 4 On the object **ext1**, select Boundary 166 only.

#### *Partition Domains 1 (pard1)*

- 1 In the **Geometry** toolbar, click  **Booleans and Partitions** and choose **Partition Domains**.
- 2 On the object **ext1**, select Domains 6, 8, 15, and 16 only.

#### *Work Plane 2 (wp2)*

- 1 In the **Geometry** toolbar, click  **Work Plane**.
- 2 In the **Settings** window for **Work Plane**, locate the **Plane Definition** section.
- 3 From the **Plane type** list, choose **Face parallel**.
- 4 On the object **pard1**, select Boundary 189 only.

*Partition Domains 2 (pard2)*

- 1 In the **Geometry** toolbar, click  **Booleans and Partitions** and choose **Partition Domains**.
- 2 On the object **pard1**, select Domains 3, 17, and 23–29 only.

*Delete Entities 2 (del2)*

- 1 Right-click **Geometry 1** and choose **Delete Entities**.
- 2 On the object **pard2**, select Boundaries 189, 192, 199, 203, 208, 215, 219, 223, and 230 only.

*Partition Domains 3 (pard3)*

- 1 In the **Geometry** toolbar, click  **Booleans and Partitions** and choose **Partition Domains**.
- 2 On the object **del2**, select Domain 7 only.
- 3 In the **Settings** window for **Partition Domains**, locate the **Partition Domains** section.
- 4 From the **Partition with** list, choose **Extended faces**.
- 5 On the object **del2**, select Boundary 37 only.

*Extrude 2 (ext2)*

- 1 In the **Geometry** toolbar, click  **Extrude**.
- 2 In the **Settings** window for **Extrude**, locate the **General** section.
- 3 From the **Extrude from** list, choose **Faces**.
- 4 On the object **pard3**, select Boundaries 34, 42, 81, 89, 167, 173, 182, and 188 only.
- 5 Locate the **Distances** section. In the table, enter the following settings:

---

<b>Distances (m)</b>
0.02 [m]

---

*Extrude 3 (ext3)*

- 1 In the **Geometry** toolbar, click  **Extrude**.
- 2 In the **Settings** window for **Extrude**, locate the **General** section.
- 3 From the **Extrude from** list, choose **Faces**.
- 4 On the object **ext2**, select Boundary 13 only.
- 5 Locate the **Distances** section. In the table, enter the following settings:

---

<b>Distances (m)</b>
0.02 [m]

---

6 Select the **Reverse direction** checkbox.

*Extrude 4 (ext4)*

- 1 In the **Geometry** toolbar, click  **Extrude**.
- 2 In the **Settings** window for **Extrude**, locate the **General** section.
- 3 From the **Extrude from** list, choose **Faces**.
- 4 On the object **ext3**, select Boundary 125 only.
- 5 Locate the **Distances** section. In the table, enter the following settings:

---

**Distances (m)**

---

0.06 [m]

---

*Partition Domains 4 (pard4)*

- 1 In the **Geometry** toolbar, click  **Booleans and Partitions** and choose **Partition Domains**.
- 2 On the object **ext4**, select Domain 16 only.
- 3 In the **Settings** window for **Partition Domains**, locate the **Partition Domains** section.
- 4 From the **Partition with** list, choose **Extended faces**.
- 5 On the object **ext4**, select Boundary 76 only.

*Partition Domains 5 (pard5)*

- 1 In the **Geometry** toolbar, click  **Booleans and Partitions** and choose **Partition Domains**.
- 2 On the object **pard4**, select Domain 16 only.
- 3 In the **Settings** window for **Partition Domains**, locate the **Partition Domains** section.
- 4 From the **Partition with** list, choose **Extended faces**.
- 5 On the object **pard4**, select Boundary 78 only.

*Partition Domains 6 (pard6)*

- 1 In the **Geometry** toolbar, click  **Booleans and Partitions** and choose **Partition Domains**.
- 2 On the object **pard5**, select Domain 14 only.
- 3 In the **Settings** window for **Partition Domains**, locate the **Partition Domains** section.
- 4 From the **Partition with** list, choose **Extended faces**.
- 5 On the object **pard5**, select Boundary 78 only.

### *Partition Domains 7 (pard7)*

- 1 In the **Geometry** toolbar, click  **Booleans and Partitions** and choose **Partition Domains**.
- 2 On the object **pard6**, select Domain 14 only.
- 3 In the **Settings** window for **Partition Domains**, locate the **Partition Domains** section.
- 4 From the **Partition with** list, choose **Extended faces**.
- 5 On the object **pard6**, select Boundary 79 only.

Finally, use the **Remove Details** functionality to remove unnecessary vertices.

### *Remove Details I (rmd1)*

- 1 In the **Geometry** toolbar, click  **Virtual Operations** and choose **Remove Details**.
- 2 In the **Settings** window for **Remove Details**, locate the **Details to Remove** section.
- 3 Clear the **Short edges** checkbox.
- 4 Clear the **Small faces** checkbox.
- 5 Clear the **Sliver faces** checkbox.
- 6 Clear the **Narrow face regions** checkbox.
- 7 Clear the **Thin domains** checkbox.
- 8 Right-click **Remove Details I (rmd1)** and choose **Build All Objects**.

9 Click the  **Zoom Extents** button in the **Graphics** toolbar.

The final geometry with boundaries 1, 2, 4, 5, 6, 7, 134, 135, 319 and 320 hidden is shown in the figure below.

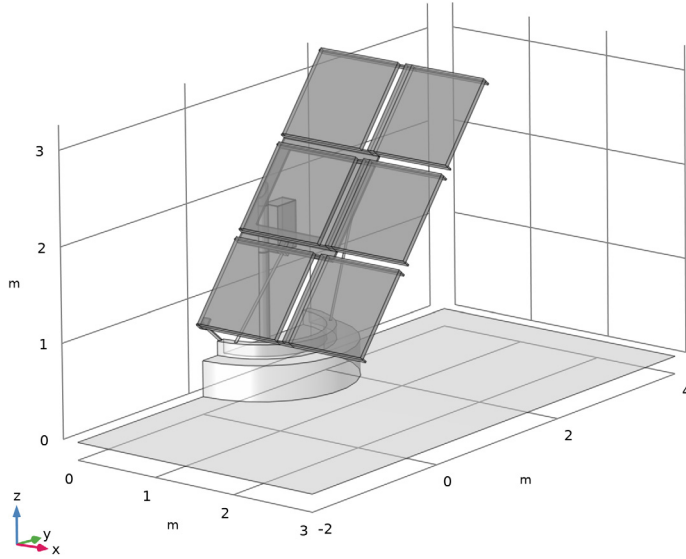

Disable the analysis of the geometry as the remaining small geometric details can be kept.

10 In the **Model Builder** window, click **Geometry I**.

11 In the **Settings** window for **Geometry**, locate the **Cleanup** section.

12 Clear the **Automatic detection of small details** checkbox.

The geometry contains both the fluid and solid domains. Proceed with the mesh.

## MESH I

The following meshing instructions are rather long. In practice, advanced meshing requires several views, but to follow the instructions below, the best way is to use the selection list.

1 In the **Model Builder** window, under **Component I (comp1)** click **Mesh I**.

2 In the **Settings** window for **Mesh**, locate the **Sequence Type** section.

3 From the list, choose **User-controlled mesh**.

### Size

- 1 In the **Model Builder** window, under **Component 1 (comp1) > Mesh 1** click **Size**.
- 2 In the **Settings** window for **Size**, locate the **Element Size** section.
- 3 Click the **Custom** button.
- 4 Locate the **Element Size Parameters** section. In the **Minimum element size** text field, type 0.005.
- 5 Click  **Build Selected**.

### Size 1

In the **Model Builder** window, right-click **Size 1** and choose **Delete**. Delete also **Corner Refinement 1** and **Free Tetrahedral 1**.

### Mapped 1

- 1 In the **Mesh** toolbar, click  **More Generators** and choose **Mapped**.
- 2 Select Boundaries 162, 163, and 165 only.

### Distribution 1

- 1 Right-click **Mapped 1** and choose **Distribution**.
- 2 Select Edges 249 and 366 only.
- 3 In the **Settings** window for **Distribution**, locate the **Distribution** section.
- 4 From the **Distribution type** list, choose **Predefined**.
- 5 In the **Number of elements** text field, type 26.
- 6 In the **Element ratio** text field, type 9.
- 7 Select the **Symmetric distribution** checkbox.

### Distribution 2

- 1 In the **Model Builder** window, right-click **Mapped 1** and choose **Distribution**.
- 2 Select Edges 248, 250, 254, and 255 only.
- 3 In the **Settings** window for **Distribution**, locate the **Distribution** section.
- 4 From the **Distribution type** list, choose **Predefined**.
- 5 In the **Number of elements** text field, type 28.
- 6 In the **Element ratio** text field, type 3.
- 7 Select the **Symmetric distribution** checkbox.

### Distribution 3

- 1 Right-click **Mapped 1** and choose **Distribution**.

- 2 Select Edges 247 and 253 only.
- 3 In the **Settings** window for **Distribution**, locate the **Distribution** section.
- 4 In the **Number of elements** text field, type 3.

#### *Swept 1*

- 1 In the **Mesh** toolbar, click  **Swept**.
- 2 In the **Settings** window for **Swept**, locate the **Domain Selection** section.
- 3 From the **Geometric entity level** list, choose **Domain**.
- 4 Select Domain 32 only.

#### *Distribution 1*

- 1 Right-click **Swept 1** and choose **Distribution**.
- 2 In the **Settings** window for **Distribution**, locate the **Distribution** section.
- 3 In the **Number of elements** text field, type 4.

#### *Copy Domain 1*

- 1 In the **Model Builder** window, right-click **Mesh 1** and choose **Copying Operations > Copy Domain**.
- 2 Select Domain 32 only.
- 3 In the **Settings** window for **Copy Domain**, locate the **Destination Domains** section.
- 4 Click to select the  **Activate Selection** toggle button.
- 5 Select Domains 29 and 31 only.

#### *Mapped 2*

- 1 In the **Mesh** toolbar, click  **More Generators** and choose **Mapped**.
- 2 Select Boundaries 116 and 130 only.

#### *Distribution 1*

- 1 Right-click **Mapped 2** and choose **Distribution**.
- 2 Select Edges 161 and 190 only.
- 3 In the **Settings** window for **Distribution**, locate the **Distribution** section.
- 4 In the **Number of elements** text field, type 3.

#### *Mapped 3*

- 1 In the **Mesh** toolbar, click  **More Generators** and choose **Mapped**.
- 2 Select Boundaries 211 and 212 only.

#### *Distribution 1*

- 1 Right-click **Mapped 3** and choose **Distribution**.
- 2 Select Edges 367 and 370 only.
- 3 In the **Settings** window for **Distribution**, locate the **Distribution** section.
- 4 In the **Number of elements** text field, type 6.

#### *Mapped 4*

- 1 In the **Mesh** toolbar, click  **More Generators** and choose **Mapped**.
- 2 Select Boundaries 256, 259, and 266 only.
- 3 In the **Settings** window for **Mapped**, click to expand the **Reduce Element Skewness** section.
- 4 Select the **Adjust edge mesh** checkbox.

#### *Distribution 1*

- 1 Right-click **Mapped 4** and choose **Distribution**.
- 2 Select Edge 431 only.
- 3 In the **Settings** window for **Distribution**, locate the **Distribution** section.
- 4 In the **Number of elements** text field, type 3.

#### *Distribution 2*

- 1 In the **Model Builder** window, right-click **Mapped 4** and choose **Distribution**.
- 2 Select Edges 435 and 516 only.
- 3 In the **Settings** window for **Distribution**, locate the **Distribution** section.
- 4 From the **Distribution type** list, choose **Predefined**.
- 5 In the **Number of elements** text field, type 26.
- 6 In the **Element ratio** text field, type 9.
- 7 Select the **Symmetric distribution** checkbox.

#### *Distribution 3*

- 1 Right-click **Mapped 4** and choose **Distribution**.
- 2 Select Edge 436 only.
- 3 In the **Settings** window for **Distribution**, locate the **Distribution** section.
- 4 In the **Number of elements** text field, type 4.

#### *Mapped 5*

- 1 In the **Mesh** toolbar, click  **More Generators** and choose **Mapped**.
- 2 Select Boundaries 299, 302, and 306 only.

- 3 In the **Settings** window for **Mapped**, locate the **Reduce Element Skewness** section.
- 4 Select the **Adjust edge mesh** checkbox.

#### *Distribution 1*

- 1 Right-click **Mapped 5** and choose **Distribution**.
- 2 Select Edges 517 and 528 only.
- 3 In the **Settings** window for **Distribution**, locate the **Distribution** section.
- 4 From the **Distribution type** list, choose **Predefined**.
- 5 In the **Number of elements** text field, type 24.
- 6 In the **Element ratio** text field, type 2.5.
- 7 Select the **Symmetric distribution** checkbox.

#### *Distribution 2*

- 1 In the **Model Builder** window, right-click **Mapped 5** and choose **Distribution**.
- 2 Select Edge 563 only.
- 3 In the **Settings** window for **Distribution**, locate the **Distribution** section.
- 4 From the **Distribution type** list, choose **Predefined**.
- 5 In the **Number of elements** text field, type 26.
- 6 In the **Element ratio** text field, type 9.
- 7 Select the **Symmetric distribution** checkbox.

#### *Swept 2*

- 1 In the **Mesh** toolbar, click  **Swept**.
- 2 In the **Settings** window for **Swept**, locate the **Domain Selection** section.
- 3 From the **Geometric entity level** list, choose **Domain**.
- 4 Select Domain 44 only.

#### *Distribution 1*

- 1 Right-click **Swept 2** and choose **Distribution**.
- 2 In the **Settings** window for **Distribution**, locate the **Distribution** section.
- 3 In the **Number of elements** text field, type 4.

#### *Copy Domain 2*

- 1 In the **Model Builder** window, right-click **Mesh 1** and choose **Copying Operations > Copy Domain**.
- 2 Select Domain 44 only.

- 3 In the **Settings** window for **Copy Domain**, locate the **Destination Domains** section.
- 4 Click to select the  **Activate Selection** toggle button.
- 5 Select Domains 37 and 39 only.

#### *Swept 3*

- 1 In the **Mesh** toolbar, click  **Swept**.
- 2 In the **Settings** window for **Swept**, locate the **Domain Selection** section.
- 3 From the **Geometric entity level** list, choose **Domain**.
- 4 Select Domains 26 and 46 only.

#### *Distribution 1*

- 1 Right-click **Swept 3** and choose **Distribution**.
- 2 In the **Settings** window for **Distribution**, locate the **Domain Selection** section.
- 3 In the list box, select **46**.
- 4 Click  **Remove from Selection**.
- 5 Select Domain 26 only.
- 6 Locate the **Distribution** section. From the **Distribution type** list, choose **Predefined**.
- 7 In the **Number of elements** text field, type 6.
- 8 In the **Element ratio** text field, type 2.
- 9 Select the **Symmetric distribution** checkbox.

#### *Copy Domain 3*

- 1 In the **Model Builder** window, right-click **Mesh 1** and choose **Copying Operations > Copy Domain**.
- 2 Select Domains 26 and 46 only.
- 3 In the **Settings** window for **Copy Domain**, locate the **Destination Domains** section.
- 4 Click to select the  **Activate Selection** toggle button.
- 5 Select Domain 28 only.

#### *Copy Domain 4*

- 1 Right-click **Mesh 1** and choose **Copying Operations > Copy Domain**.
- 2 Select Domains 26 and 46 only.
- 3 In the **Settings** window for **Copy Domain**, locate the **Destination Domains** section.
- 4 Click to select the  **Activate Selection** toggle button.
- 5 Select Domains 10 and 41 only.

### *Copy Domain 5*

- 1 Right-click **Mesh 1** and choose **Copying Operations > Copy Domain**.
- 2 Select Domains 10 and 41 only.
- 3 In the **Settings** window for **Copy Domain**, locate the **Destination Domains** section.
- 4 Click to select the  **Activate Selection** toggle button.
- 5 Select Domains 7 and 38 only.

### *Mapped 6*

- 1 In the **Mesh** toolbar, click  **More Generators** and choose **Mapped**.
- 2 Select Boundary 104 only.

### *Distribution 1*

- 1 Right-click **Mapped 6** and choose **Distribution**.
- 2 Select Edge 148 only.
- 3 In the **Settings** window for **Distribution**, locate the **Distribution** section.
- 4 In the **Number of elements** text field, type 3.

### *Mapped 7*

- 1 In the **Mesh** toolbar, click  **More Generators** and choose **Mapped**.
- 2 Select Boundary 209 only.

### *Distribution 1*

- 1 Right-click **Mapped 7** and choose **Distribution**.
- 2 Select Edge 360 only.
- 3 In the **Settings** window for **Distribution**, locate the **Distribution** section.
- 4 In the **Number of elements** text field, type 6.

### *Swept 4*

- 1 In the **Mesh** toolbar, click  **Swept**.
- 2 In the **Settings** window for **Swept**, locate the **Domain Selection** section.
- 3 From the **Geometric entity level** list, choose **Domain**.
- 4 Select Domains 23 and 43 only.

### *Distribution 1*

Right-click **Swept 4** and choose **Distribution**.

### *Mapped 8*

- 1 In the **Mesh** toolbar, click  **More Generators** and choose **Mapped**.

2 Select Boundary 112 only.

#### *Distribution 1*

- 1 Right-click **Mapped 8** and choose **Distribution**.
- 2 Select Edges 153 and 508 only.
- 3 In the **Settings** window for **Distribution**, locate the **Distribution** section.
- 4 From the **Distribution type** list, choose **Predefined**.
- 5 In the **Number of elements** text field, type 7.
- 6 In the **Element ratio** text field, type 2.
- 7 Select the **Symmetric distribution** checkbox.

#### *Swept 5*

- 1 In the **Mesh** toolbar, click  **Swept**.
- 2 In the **Settings** window for **Swept**, locate the **Domain Selection** section.
- 3 From the **Geometric entity level** list, choose **Domain**.
- 4 Select Domains 24, 25, and 27 only.

#### *Distribution 1*

- 1 Right-click **Swept 5** and choose **Distribution**.
- 2 In the **Settings** window for **Distribution**, locate the **Distribution** section.
- 3 In the **Number of elements** text field, type 2.

#### *Mapped 9*

- 1 In the **Mesh** toolbar, click  **More Generators** and choose **Mapped**.
- 2 Select Boundaries 54, 190, and 197 only.

#### *Distribution 1*

- 1 Right-click **Mapped 9** and choose **Distribution**.
- 2 Select Edges 312 and 314 only.
- 3 In the **Settings** window for **Distribution**, locate the **Distribution** section.
- 4 In the **Number of elements** text field, type 2.

#### *Distribution 2*

- 1 In the **Model Builder** window, right-click **Mapped 9** and choose **Distribution**.
- 2 Select Edges 76 and 78 only.
- 3 In the **Settings** window for **Distribution**, locate the **Distribution** section.
- 4 From the **Distribution type** list, choose **Predefined**.

- 5 In the **Number of elements** text field, type 16.
- 6 In the **Element ratio** text field, type 3.
- 7 From the **Growth rate** list, choose **Exponential**.
- 8 Select the **Reverse direction** checkbox.

#### *Distribution 3*

- 1 Right-click **Mapped 9** and choose **Distribution**.
- 2 Select Edges 327 and 329 only.
- 3 In the **Settings** window for **Distribution**, locate the **Distribution** section.
- 4 From the **Distribution type** list, choose **Predefined**.
- 5 In the **Number of elements** text field, type 19.
- 6 In the **Element ratio** text field, type 2.5.
- 7 From the **Growth rate** list, choose **Exponential**.

#### *Distribution 4*

- 1 Right-click **Mapped 9** and choose **Distribution**.
- 2 Select Edge 75 only.
- 3 In the **Settings** window for **Distribution**, locate the **Distribution** section.
- 4 In the **Number of elements** text field, type 3.

#### *Swept 6*

- 1 In the **Mesh** toolbar, click  **Swept**.
- 2 In the **Settings** window for **Swept**, locate the **Domain Selection** section.
- 3 From the **Geometric entity level** list, choose **Domain**.
- 4 Select Domain 11 only.
- 5 Click to expand the **Source Faces** section. Select Boundaries 54, 190, and 197 only.
- 6 Click to expand the **Destination Faces** section. Select Boundary 49 only.

#### *Distribution 1*



- 1 Right-click **Swept 6** and choose **Distribution**.
- 2 In the **Settings** window for **Distribution**, locate the **Distribution** section.
- 3 In the **Number of elements** text field, type 2.

#### *Copy Domain 6*

- 1 In the **Model Builder** window, right-click **Mesh 1** and choose **Copying Operations > Copy Domain**.

- 2 Select Domain 11 only.
- 3 In the **Settings** window for **Copy Domain**, locate the **Destination Domains** section.
- 4 Click to select the  **Activate Selection** toggle button.
- 5 Select Domain 8 only.

#### *Swept 7*

- 1 In the **Mesh** toolbar, click  **Swept**.
- 2 In the **Settings** window for **Swept**, locate the **Domain Selection** section.
- 3 From the **Geometric entity level** list, choose **Domain**.
- 4 Select Domains 40, 42, 45, and 47 only.
- 5 Locate the **Source Faces** section. Click to select the  **Activate Selection** toggle button.
- 6 Select Boundaries 228, 238, 251, and 261 only.

#### *Distribution 1*

- 1 Right-click **Swept 7** and choose **Distribution**.
- 2 In the **Settings** window for **Distribution**, locate the **Distribution** section.
- 3 In the **Number of elements** text field, type 2.

#### *Mapped 10*

- 1 In the **Mesh** toolbar, click  **More Generators** and choose **Mapped**.
- 2 Select Boundaries 43, 188, and 196 only.

#### *Distribution 1*

- 1 Right-click **Mapped 10** and choose **Distribution**.
- 2 Select Edges 62, 307, 323, and 479 only.
- 3 In the **Settings** window for **Distribution**, locate the **Distribution** section.
- 4 From the **Distribution type** list, choose **Predefined**.
- 5 In the **Number of elements** text field, type 7.
- 6 In the **Element ratio** text field, type 2.
- 7 Select the **Symmetric distribution** checkbox.

#### *Swept 8*

- 1 In the **Mesh** toolbar, click  **Swept**.
- 2 In the **Settings** window for **Swept**, locate the **Domain Selection** section.
- 3 From the **Geometric entity level** list, choose **Domain**.
- 4 Select Domain 9 only.

#### *Distribution 1*

- 1 Right-click **Swept 8** and choose **Distribution**.
- 2 In the **Settings** window for **Distribution**, locate the **Distribution** section.
- 3 In the **Number of elements** text field, type 2.

#### *Free Triangular 1*

- 1 In the **Mesh** toolbar, click  **More Generators** and choose **Free Triangular**.
- 2 Select Boundary 213 only.

#### *Distribution 1*

- 1 Right-click **Free Triangular 1** and choose **Distribution**.
- 2 Select Edges 372 and 373 only.
- 3 In the **Settings** window for **Distribution**, locate the **Distribution** section.
- 4 In the **Number of elements** text field, type 12.

#### *Mapped 11*

- 1 In the **Mesh** toolbar, click  **More Generators** and choose **Mapped**.
- 2 Select Boundaries 71 and 98 only.

#### *Distribution 1*

- 1 Right-click **Mapped 11** and choose **Distribution**.
- 2 Select Edges 133 and 143 only.
- 3 In the **Settings** window for **Distribution**, locate the **Distribution** section.
- 4 In the **Number of elements** text field, type 3.

#### *Distribution 2*

- 1 In the **Model Builder** window, right-click **Mapped 11** and choose **Distribution**.
- 2 Select Edges 95 and 107 only.
- 3 In the **Settings** window for **Distribution**, locate the **Distribution** section.
- 4 In the **Number of elements** text field, type 6.

#### *Free Triangular 2*

- 1 In the **Mesh** toolbar, click  **More Generators** and choose **Free Triangular**.
- 2 Select Boundary 77 only.

#### *Free Quad 1*

- 1 In the **Mesh** toolbar, click  **More Generators** and choose **Free Quad**.
- 2 Select Boundary 55 only.

### *Size 1*

- 1 Right-click **Free Quad 1** and choose **Size**.
- 2 In the **Settings** window for **Size**, locate the **Element Size** section.
- 3 Click the **Custom** button.
- 4 Locate the **Element Size Parameters** section.
- 5 Select the **Maximum element size** checkbox. In the associated text field, type 0.05.

### *Distribution 1*

- 1 In the **Model Builder** window, right-click **Free Quad 1** and choose **Distribution**.
- 2 Select Edge 493 only.
- 3 In the **Settings** window for **Distribution**, locate the **Distribution** section.
- 4 From the **Distribution type** list, choose **Predefined**.
- 5 In the **Number of elements** text field, type 32.
- 6 In the **Element ratio** text field, type 3.5.
- 7 Select the **Symmetric distribution** checkbox.

### *Distribution 2*

- 1 Right-click **Free Quad 1** and choose **Distribution**.
- 2 Select Edge 333 only.
- 3 In the **Settings** window for **Distribution**, locate the **Distribution** section.
- 4 From the **Distribution type** list, choose **Predefined**.
- 5 In the **Number of elements** text field, type 28.
- 6 In the **Element ratio** text field, type 3.

### *Distribution 3*

- 1 Right-click **Free Quad 1** and choose **Distribution**.
- 2 Select Edges 77 and 142 only.
- 3 In the **Settings** window for **Distribution**, locate the **Distribution** section.
- 4 From the **Distribution type** list, choose **Predefined**.
- 5 In the **Number of elements** text field, type 16.
- 6 In the **Element ratio** text field, type 3.
- 7 Select the **Symmetric distribution** checkbox.

### *Distribution 4*

- 1 Right-click **Free Quad 1** and choose **Distribution**.

- 2 Select Edges 277 and 333 only.
- 3 In the **Settings** window for **Distribution**, locate the **Distribution** section.
- 4 From the **Distribution type** list, choose **Predefined**.
- 5 In the **Number of elements** text field, type 28.
- 6 In the **Element ratio** text field, type 3.
- 7 Select the **Reverse direction** checkbox.

#### *Swept 9*

- 1 In the **Mesh** toolbar, click  **Swept**.
- 2 In the **Settings** window for **Swept**, locate the **Domain Selection** section.
- 3 From the **Geometric entity level** list, choose **Domain**.
- 4 Select Domain 12 only.

#### *Distribution 1*

Right-click **Swept 9** and choose **Distribution**.

#### *Swept 10*

- 1 In the **Mesh** toolbar, click  **Swept**.
- 2 In the **Settings** window for **Swept**, locate the **Domain Selection** section.
- 3 From the **Geometric entity level** list, choose **Domain**.
- 4 Select Domain 34 only.

#### *Distribution 1*

- 1 Right-click **Swept 10** and choose **Distribution**.
- 2 In the **Settings** window for **Distribution**, locate the **Distribution** section.
- 3 From the **Distribution type** list, choose **Predefined**.
- 4 In the **Number of elements** text field, type 60.
- 5 In the **Element ratio** text field, type 3.
- 6 Select the **Symmetric distribution** checkbox.

#### *Swept 11*

- 1 In the **Mesh** toolbar, click  **Swept**.
- 2 In the **Settings** window for **Swept**, locate the **Domain Selection** section.
- 3 From the **Geometric entity level** list, choose **Domain**.
- 4 Select Domains 17 and 22 only.

#### *Distribution 1*

- 1 Right-click **Swept 11** and choose **Distribution**.
- 2 In the **Settings** window for **Distribution**, locate the **Distribution** section.
- 3 In the **Number of elements** text field, type 8.

#### *Mapped 12*

- 1 In the **Mesh** toolbar, click  **More Generators** and choose **Mapped**.
- 2 Select Boundary 9 only.

#### *Distribution 1*

- 1 Right-click **Mapped 12** and choose **Distribution**.
- 2 Select Edge 11 only.
- 3 In the **Settings** window for **Distribution**, locate the **Distribution** section.
- 4 In the **Number of elements** text field, type 3.

#### *Mapped 13*

- 1 In the **Mesh** toolbar, click  **More Generators** and choose **Mapped**.
- 2 Select Boundary 202 only.

#### *Distribution 1*

- 1 Right-click **Mapped 13** and choose **Distribution**.
- 2 Select Edge 341 only.
- 3 In the **Settings** window for **Distribution**, locate the **Distribution** section.
- 4 In the **Number of elements** text field, type 6.

#### *Mapped 14*

- 1 In the **Mesh** toolbar, click  **More Generators** and choose **Mapped**.
- 2 Select Boundaries 13 and 149 only.

#### *Distribution 1*

- 1 Right-click **Mapped 14** and choose **Distribution**.
- 2 Select Edge 16 only.
- 3 In the **Settings** window for **Distribution**, locate the **Distribution** section.
- 4 In the **Number of elements** text field, type 3.

#### *Distribution 2*

- 1 In the **Model Builder** window, right-click **Mapped 14** and choose **Distribution**.
- 2 Select Edge 14 only.

- 3 In the **Settings** window for **Distribution**, locate the **Distribution** section.
- 4 In the **Number of elements** text field, type 3.

#### *Distribution 3*

- 1 Right-click **Mapped 14** and choose **Distribution**.
- 2 Select Edge 225 only.
- 3 In the **Settings** window for **Distribution**, locate the **Distribution** section.
- 4 In the **Number of elements** text field, type 2.

#### *Mapped 15*

- 1 In the **Mesh** toolbar, click  **More Generators** and choose **Mapped**.
- 2 Select Boundary 170 only.

#### *Distribution 1*

- 1 Right-click **Mapped 15** and choose **Distribution**.
- 2 Select Edges 267 and 270 only.
- 3 In the **Settings** window for **Distribution**, locate the **Distribution** section.
- 4 From the **Distribution type** list, choose **Predefined**.
- 5 In the **Number of elements** text field, type 26.
- 6 In the **Element ratio** text field, type 3.
- 7 Select the **Symmetric distribution** checkbox.

#### *Swept 12*

- 1 In the **Mesh** toolbar, click  **Swept**.
- 2 In the **Settings** window for **Swept**, locate the **Domain Selection** section.
- 3 From the **Geometric entity level** list, choose **Domain**.
- 4 Select Domains 3 and 30 only.

#### *Distribution 1*

- 1 Right-click **Swept 12** and choose **Distribution**.
- 2 In the **Settings** window for **Distribution**, locate the **Distribution** section.
- 3 From the **Distribution type** list, choose **Predefined**.
- 4 In the **Number of elements** text field, type 6.
- 5 In the **Element ratio** text field, type 2.
- 6 Select the **Symmetric distribution** checkbox.

### *Swept 13*

- 1 In the **Mesh** toolbar, click  **Swept**.
- 2 In the **Settings** window for **Swept**, locate the **Domain Selection** section.
- 3 From the **Geometric entity level** list, choose **Domain**.
- 4 Select Domain 36 only.

### *Swept 14*

- 1 In the **Mesh** toolbar, click  **Swept**.
- 2 In the **Settings** window for **Swept**, locate the **Domain Selection** section.
- 3 From the **Geometric entity level** list, choose **Domain**.
- 4 Select Domain 4 only.

### *Distribution 1*

- 1 Right-click **Swept 14** and choose **Distribution**.
- 2 In the **Settings** window for **Distribution**, locate the **Distribution** section.
- 3 In the **Number of elements** text field, type 2.

### *Free Triangular 3*

- 1 In the **Mesh** toolbar, click  **More Generators** and choose **Free Triangular**.
- 2 Select Boundary 21 only.

### *Distribution 1*

- 1 Right-click **Free Triangular 3** and choose **Distribution**.
- 2 Select Edges 26 and 33 only.
- 3 In the **Settings** window for **Distribution**, locate the **Distribution** section.
- 4 In the **Number of elements** text field, type 3.

### *Free Triangular 4*

- 1 In the **Mesh** toolbar, click  **More Generators** and choose **Free Triangular**.
- 2 Select Boundary 19 only.

### *Size 1*

- 1 Right-click **Free Triangular 4** and choose **Size**.
- 2 In the **Settings** window for **Size**, locate the **Element Size** section.
- 3 Click the **Custom** button.
- 4 Locate the **Element Size Parameters** section.
- 5 Select the **Maximum element size** checkbox. In the associated text field, type 0.02.

### *Swept 15*

- 1 In the **Mesh** toolbar, click  **Swept**.
- 2 In the **Settings** window for **Swept**, locate the **Domain Selection** section.
- 3 From the **Geometric entity level** list, choose **Domain**.
- 4 Select Domain 5 only.

### *Free Triangular 5*

- 1 In the **Mesh** toolbar, click  **More Generators** and choose **Free Triangular**.
- 2 Select Boundary 193 only.

### *Distribution 1*

- 1 Right-click **Free Triangular 5** and choose **Distribution**.
- 2 Select Edges 318 and 319 only.

### *Swept 16*

- 1 In the **Mesh** toolbar, click  **Swept**.
- 2 In the **Settings** window for **Swept**, locate the **Domain Selection** section.
- 3 From the **Geometric entity level** list, choose **Domain**.
- 4 Select Domain 6 only.

### *Distribution 1*

- 1 Right-click **Swept 16** and choose **Distribution**.
- 2 In the **Settings** window for **Distribution**, locate the **Distribution** section.
- 3 From the **Distribution type** list, choose **Predefined**.
- 4 In the **Number of elements** text field, type 15.
- 5 In the **Element ratio** text field, type 2.
- 6 Select the **Symmetric distribution** checkbox.

### *Free Tetrahedral 1*

- 1 In the **Mesh** toolbar, click  **Free Tetrahedral**.
- 2 In the **Settings** window for **Free Tetrahedral**, locate the **Domain Selection** section.
- 3 From the **Geometric entity level** list, choose **Domain**.
- 4 Select Domain 35 only.

### *Size 1*

- 1 Right-click **Free Tetrahedral 1** and choose **Size**.
- 2 In the **Settings** window for **Size**, locate the **Element Size** section.

- 3 Click the **Custom** button.
- 4 Locate the **Element Size Parameters** section.
- 5 Select the **Maximum element size** checkbox. In the associated text field, type 0.033.

#### *Swept 17*

- 1 In the **Mesh** toolbar, click  **Swept**.
- 2 In the **Settings** window for **Swept**, locate the **Domain Selection** section.
- 3 From the **Geometric entity level** list, choose **Domain**.
- 4 Select Domain 33 only.

#### *Distribution 1*

- 1 Right-click **Swept 17** and choose **Distribution**.
- 2 In the **Settings** window for **Distribution**, locate the **Distribution** section.
- 3 From the **Distribution type** list, choose **Predefined**.
- 4 In the **Number of elements** text field, type 40.
- 5 In the **Element ratio** text field, type 3.
- 6 Select the **Symmetric distribution** checkbox.

#### *Swept 18*

- 1 In the **Mesh** toolbar, click  **Swept**.
- 2 In the **Settings** window for **Swept**, locate the **Domain Selection** section.
- 3 From the **Geometric entity level** list, choose **Domain**.
- 4 Select Domain 16 only.

#### *Free Tetrahedral 2*

- 1 In the **Mesh** toolbar, click  **Free Tetrahedral**.
- 2 In the **Settings** window for **Free Tetrahedral**, locate the **Domain Selection** section.
- 3 From the **Geometric entity level** list, choose **Domain**.
- 4 Select Domain 20 only.

#### *Swept 19*

- 1 In the **Mesh** toolbar, click  **Swept**.
- 2 In the **Settings** window for **Swept**, locate the **Domain Selection** section.
- 3 From the **Geometric entity level** list, choose **Domain**.
- 4 Select Domains 15 and 19 only.

#### *Distribution 1*

- 1 Right-click **Swept 19** and choose **Distribution**.
- 2 In the **Settings** window for **Distribution**, locate the **Distribution** section.
- 3 From the **Distribution type** list, choose **Predefined**.
- 4 In the **Number of elements** text field, type 20.
- 5 In the **Element ratio** text field, type 4.
- 6 Select the **Symmetric distribution** checkbox.

#### *Swept 20*

- 1 In the **Mesh** toolbar, click  **Swept**.
- 2 In the **Settings** window for **Swept**, locate the **Domain Selection** section.
- 3 From the **Geometric entity level** list, choose **Domain**.
- 4 Select Domain 14 only.

#### *Distribution 1*

- 1 Right-click **Swept 20** and choose **Distribution**.
- 2 In the **Settings** window for **Distribution**, locate the **Distribution** section.
- 3 In the **Number of elements** text field, type 2.

#### *Mapped 16*

- 1 In the **Mesh** toolbar, click  **More Generators** and choose **Mapped**.
- 2 Select Boundaries 58 and 93 only.

#### *Distribution 1*

- 1 Right-click **Mapped 16** and choose **Distribution**.
- 2 Select Edges 81 and 97 only.
- 3 In the **Settings** window for **Distribution**, locate the **Distribution** section.
- 4 In the **Number of elements** text field, type 6.

#### *Distribution 2*

- 1 In the **Model Builder** window, right-click **Mapped 16** and choose **Distribution**.
- 2 Select Edges 126 and 136 only.
- 3 In the **Settings** window for **Distribution**, locate the **Distribution** section.
- 4 In the **Number of elements** text field, type 3.

#### *Swept 21*

- 1 In the **Mesh** toolbar, click  **Swept**.

- 2 In the **Settings** window for **Swept**, locate the **Domain Selection** section.
- 3 From the **Geometric entity level** list, choose **Domain**.
- 4 Select Domains 13 and 21 only.

#### *Distribution 1*

- 1 Right-click **Swept 21** and choose **Distribution**.
- 2 In the **Settings** window for **Distribution**, locate the **Distribution** section.
- 3 From the **Distribution type** list, choose **Predefined**.
- 4 In the **Number of elements** text field, type 50.
- 5 In the **Element ratio** text field, type 6.
- 6 Select the **Symmetric distribution** checkbox.

#### *Free Tetrahedral 3*

- 1 In the **Mesh** toolbar, click  **Free Tetrahedral**.
- 2 In the **Settings** window for **Free Tetrahedral**, locate the **Domain Selection** section.
- 3 From the **Geometric entity level** list, choose **Domain**.
- 4 Select Domain 18 only.

#### *Free Triangular 6*

- 1 In the **Mesh** toolbar, click  **More Generators** and choose **Free Triangular**.
- 2 Select Boundary 28 only.

#### *Size 1*

- 1 Right-click **Free Triangular 6** and choose **Size**.
- 2 In the **Settings** window for **Size**, locate the **Element Size** section.
- 3 From the **Calibrate for** list, choose **Fluid dynamics**.
- 4 Click the **Custom** button.
- 5 Locate the **Element Size Parameters** section.
- 6 Select the **Maximum element size** checkbox. In the associated text field, type 0.05.
- 7 Select the **Minimum element size** checkbox. In the associated text field, type 0.015.

#### *Distribution 1*

- 1 In the **Model Builder** window, right-click **Free Triangular 6** and choose **Distribution**.
- 2 Select Edges 40 and 48 only.
- 3 In the **Settings** window for **Distribution**, locate the **Distribution** section.
- 4 In the **Number of elements** text field, type 60.

### *Mapped 17*

- 1 In the **Mesh** toolbar, click  **More Generators** and choose **Mapped**.
- 2 Select Boundaries 23, 24, 27, and 30 only.

### *Distribution 1*

- 1 Right-click **Mapped 17** and choose **Distribution**.
- 2 Select Edge 193 only.
- 3 In the **Settings** window for **Distribution**, locate the **Distribution** section.
- 4 In the **Number of elements** text field, type 6.

### *Distribution 2*

- 1 In the **Model Builder** window, right-click **Mapped 17** and choose **Distribution**.
- 2 Select Edges 184 and 186 only.

### *Distribution 3*

- 1 Right-click **Mapped 17** and choose **Distribution**.
- 2 Select Edges 29 and 187 only.
- 3 In the **Settings** window for **Distribution**, locate the **Distribution** section.
- 4 In the **Number of elements** text field, type 7.

### *Mapped 17*

- 1 Right-click **Mapped 17** and choose **Build Selected**.
- 2 Click the  **Wireframe Rendering** button in the **Graphics** toolbar.

The mesh should at this point look like the figure below. All the solid parts are now meshed and only volume mesh for the fluid domains remains.

### Size 1

1 In the **Model Builder** window, right-click **Mesh 1** and choose **Size**.

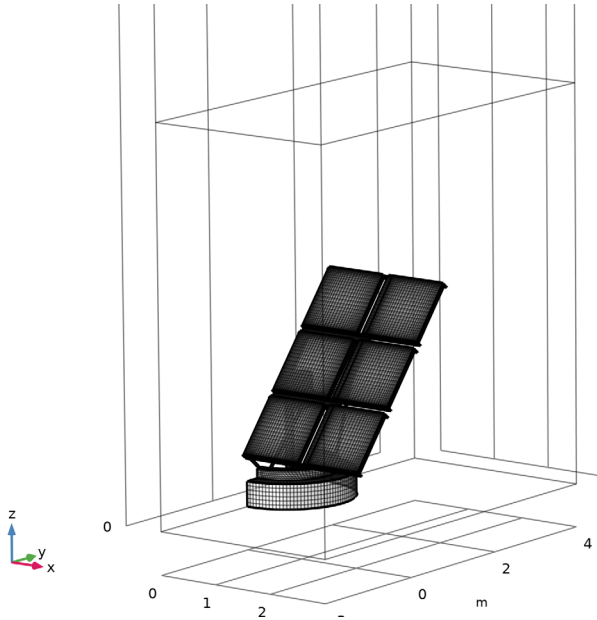

- 2 In the **Settings** window for **Size**, locate the **Geometric Entity Selection** section.
- 3 From the **Geometric entity level** list, choose **Boundary**.
- 4 Select Boundaries 3 and 74 only.
- 5 Locate the **Element Size** section. Click the **Custom** button.
- 6 Locate the **Element Size Parameters** section.
- 7 Select the **Maximum element size** checkbox. In the associated text field, type 0.15.

### Free Tetrahedral 4



- 1 In the **Mesh** toolbar, click  **Free Tetrahedral**.
- 2 In the **Settings** window for **Free Tetrahedral**, locate the **Domain Selection** section.
- 3 From the **Geometric entity level** list, choose **Domain**.
- 4 Select Domain 1 only.
- 5 Click to expand the **Element Quality Optimization** section. From the **Optimization level** list, choose **High**.

### Boundary Layers 1

- 1 In the **Model Builder** window, click **Boundary Layers 1**.

- 2 In the **Settings** window for **Boundary Layers**, locate the **Geometric Entity Selection** section.
- 3 In the list box, select **2**.
- 4 Click  **Remove from Selection**.
- 5 Select Domain 1 only.
- 6 Click to expand the **Corner Settings** section. In the **Trim for angles greater than** text field, type 280.

#### *Boundary Layer Properties I*

- 1 In the **Model Builder** window, expand the **Boundary Layers I** node, then click **Boundary Layer Properties I**.
- 2 In the **Settings** window for **Boundary Layer Properties**, locate the **Boundary Selection** section.
- 3 Click  **Clear Selection**.
- 4 Click  **Paste Selection**.
- 5 In the **Paste Selection** dialog, type 3 9 10 11 14 17 18 19 22 23 24 25 26 27 28 30 31 33 34 35 38 41 42 43 45 46 47 53 54 55 57 60 63 66 69 99 100 101 102 104 105 106 112 113 114 116 117 120 121 122 123 127 128 130 131 132 133 141 142 143 146 147 148 150 152 153 154 156 157 159 160 161 163 164 166 167 168 169 170 171 172 173 174 176 177 179 180 181 183 184 185 187 189 192 194 195 196 197 198 200 202 203 204 205 206 207 208 209 210 211 212 214 215 216 218 219 222 223 224 225 226 229 231 234 235 236 241 242 245 246 247 248 249 254 257 258 259 263 264 265 267 268 270 271 272 273 274 276 277 278 279 280 281 282 284 285 286 287 288 289 290 292 293 294 295 296 297 298 300 301 302 303 304 305 307 308 309 310 311 312 313 314 315 316 317 318 in the **Selection** text field.
- 6 Click **OK**.
- 7 In the **Settings** window for **Boundary Layer Properties**, locate the **Layers** section.
- 8 In the **Thickness adjustment factor** text field, type 1.5.

#### *Boundary Layers I*

In the **Model Builder** window, right-click **Boundary Layers I** and choose **Build Selected**.

#### *Swept 22*

- 1 In the **Mesh** toolbar, click  **Swept**.
- 2 In the **Settings** window for **Swept**, locate the **Domain Selection** section.
- 3 From the **Geometric entity level** list, choose **Domain**.

4 Select Domain 2 only.

*Distribution 1*

1 Right-click **Swept 22** and choose **Distribution**.

2 In the **Settings** window for **Distribution**, locate the **Distribution** section.

3 From the **Distribution type** list, choose **Predefined**.

4 In the **Number of elements** text field, type 25.

5 In the **Element ratio** text field, type 5.

6 Click  **Build All**.

