



Model created in COMSOL Multiphysics 6.4

Displacement Ventilation

Introduction

The present example investigates the performance of a displacement ventilation system. Given measured values for inlet velocity, inlet temperature, and heat flux, this simulation yields field configurations of air temperature and velocity that are consistent with experimental measurements and analytic global models ([Ref. 1](#)).

Model Definition

In general, there are two classes of ventilation: mixing ventilation and displacement ventilation. In displacement ventilation, air enters a room at the floor level and displaces warmer air to achieve the desired temperature. Heating sources in the room can include running electronic devices, or inlet jets of warm air. A potential issue with the displacement ventilation approach is that significant temperature variation and strong stratification may arise.

The model geometry consists of a test chamber with the dimensions 2.5 m by 3.65 m by 3 m. A warm jet enters the chamber from an inlet located at the floor center. Fresh air, at constant temperature and relatively low velocity, is supplied through a wall inlet. Heat exits the chamber through an exhaust located in the center of the ceiling. The walls of the chambers are almost perfectly insulated.

Symmetry reduces the modeling domain to half of the chamber, as shown in [Figure 1](#). The warm jet feeds $0.028 \text{ m}^3/\text{s}$ of air at a temperature of 45°C into the room. The temperature of the fresh air is 21°C and has a flow rate of $0.05 \text{ m}^3/\text{s}$.

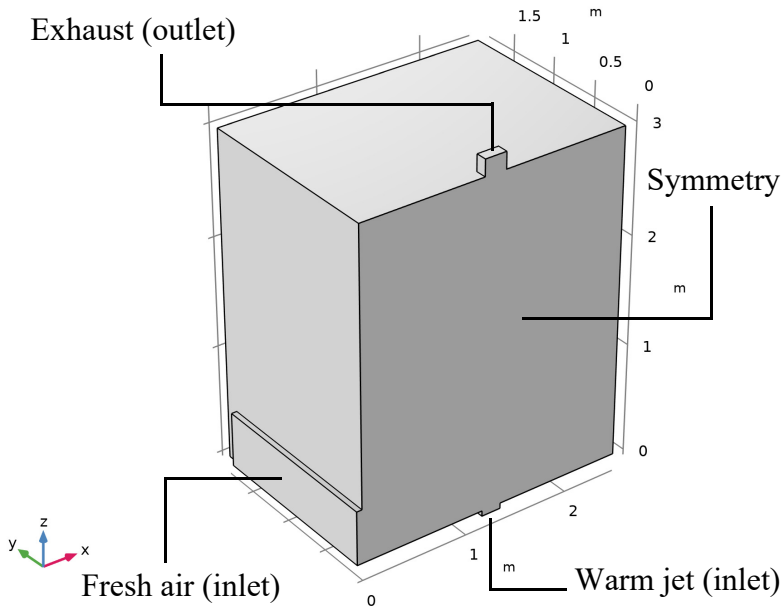

Figure 1: The modeling domain is reduced to half the chamber size due to symmetry.

Convection of heat can be either forced or free. Forced convection occurs if

$$\frac{g\alpha\Delta T}{U^2/L} \ll 1 \quad (1)$$

where g is the gravity (m/s^2), α ($1/\text{K}$) is the coefficient of thermal expansion, T (K) the temperature, U (m/s) the velocity, and L (m) refers to the characteristic length. [Equation 1](#) states that the buoyancy force is small compared to the inertial force. In such a situation, the character of the flow field is described by the Reynolds number, $\text{Re} = UL/\nu$ where ν (m^2/s) is the kinematic viscosity. Natural convection occurs if [Equation 1](#) is not fulfilled, in which case the flow field character is described by the Grashof number,

$$\text{Gr} = \frac{g\alpha\Delta TL^3}{\nu^2}$$

If the convective forces and buoyant forces are of the same order of magnitude, then $Gr^{1/2}$ can be interpreted as the ratio between the inertial and viscous forces. That is, when the Grashof number is large, the flow becomes turbulent.

To investigate if Equation 1 holds, the air can be approximated as an ideal gas in which case $\alpha = 1/T$. Furthermore, $\Delta T \approx 20$ K, $U \approx 1$ m/s, and $L \approx 2$ m. This gives

$$\frac{g\alpha\Delta T}{U^2/L} \approx \frac{9.8 \cdot 20 \cdot 2}{1^2 \cdot 300} = 1.3$$

Hence, it is the Grashof number that determines whether the flow is turbulent or laminar. Using the same approximations as above:

$$Gr \approx \frac{9.8 \cdot 20 \cdot 2^3}{(1.6 \cdot 10^{-5})^2 \cdot 300} = 2 \cdot 10^{10} \quad (2)$$

Equation 2 clearly indicates that the flow is turbulent.

Modeling Considerations

The flow is modeled using the $k-\omega$ model. The main reason for using the $k-\omega$ model over the $k-\epsilon$ model is that the former is in general more reliable when it comes to predicting the spreading rate of jets (Ref. 2).

As can be seen in Figure 1, the inlets and the outlet have been extended with small domains. This is to avoid having velocity conditions perpendicular to the no-penetration conditions of the walls, which often turns out to be numerically unstable.

Results and Discussion

Figure 2 shows a streamline plot colored by the temperature. As expected, there is a stratification at $z \approx 1$ m with a complicated recirculation pattern above.

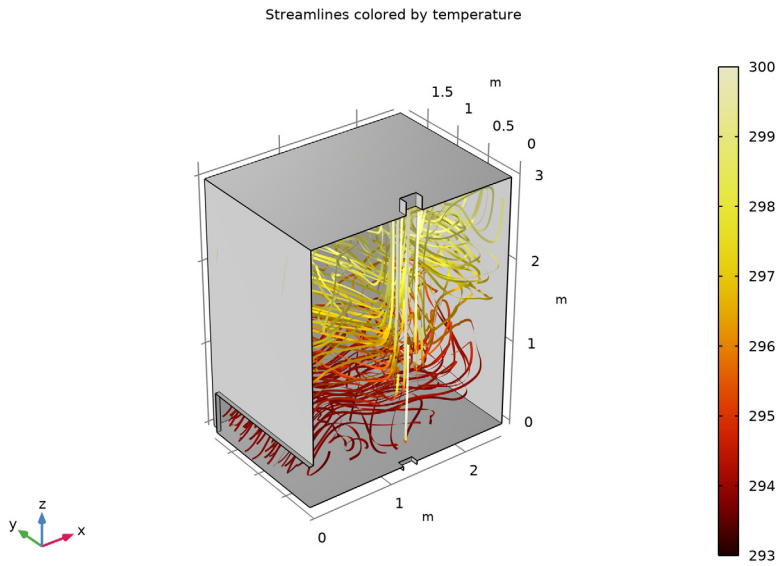

Figure 2: Streamlines colored by the temperature illustrating the velocity field.

A more quantitative picture is given in [Figure 3](#) which shows isosurfaces of the temperature field. The stratification is even more clearly visible here. The result compares well with the experimental results in [Ref. 1](#).

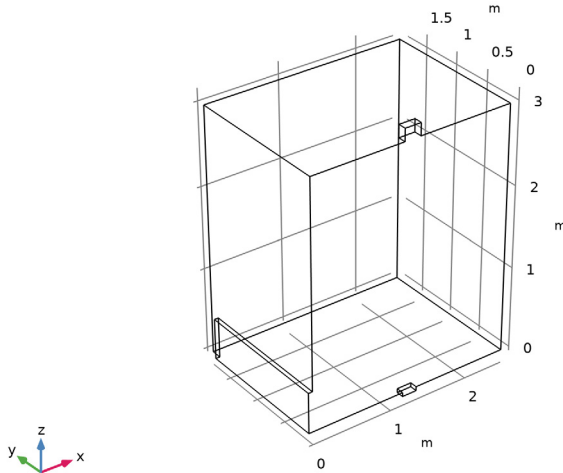

Figure 3: Isosurfaces of the temperature.

[Figure 4](#) shows a comparison of the computed and measured temperature along the line $(1.25,0,0) \rightarrow (1.25,0,3)$, that is through the center of the jet. While the computational result captures the main trend with decreasing temperature with height, it still over predicts the experimental result with 2°C at $z = 2.6$ m. There are two possible reasons for this. The first is, as mentioned in [Ref. 1](#), that the test chamber is not as well insulated as intended. The other possible explanation is that the buoyancy induced production in the

k and ω equations (see for example Ref. 3) must be included in order to reproduce the experimental results more accurately.

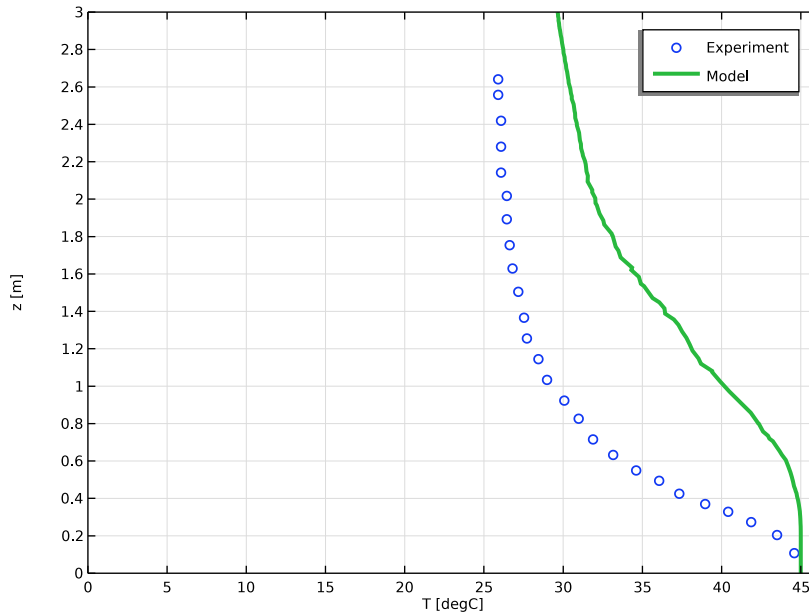

Figure 4: Plume temperature.

References

1. D. Mazoni and P. Guitton, “Validation of Displacement Ventilation Simplified Models,” *Proceedings of ‘Building Simulation ’97’*, the Fifth International IBSPA Conference, vol. I, pp. 233–239, International Building Performance Simulation Association (IBSPA), 1997.
2. D.C. Wilcox, *Turbulence Model for CFD*, 2nd ed., DCW Industries, La Canada, CA, 1998.
3. S. Tieszen, A. Ooi, P. Durbin, and M. Behnia, “Modeling of Natural Convection Heat Transfer,” *Proceedings of the Summer Program 1998*, Stanford: Center for Turbulence Research, 1998.

Application Library path: CFD_Module/Nonisothermal_Flow/
displacement_ventilation



Modeling Instructions

From the **File** menu, choose **New**.

NEW

In the **New** window, click  **Model Wizard**.

MODEL WIZARD

- 1 In the **Model Wizard** window, click  **3D**.
- 2 In the **Select Physics** tree, select **Fluid Flow** > **Nonisothermal Flow** > **Turbulent Flow** > **Turbulent Flow, k- ω** .
- 3 Click **Add**.
- 4 Click  **Study**.
- 5 In the **Select Study** tree, select **General Studies** > **Stationary**.
- 6 Click  **Done**.

GLOBAL DEFINITIONS

Parameters I

- 1 In the **Model Builder** window, under **Global Definitions** click **Parameters I**.
- 2 In the **Settings** window for **Parameters**, locate the **Parameters** section.
- 3 In the table, enter the following settings:

Name	Expression	Value	Description
H	3[m]	3 m	Room height
D	2.5[m]	2.5 m	Room depth
W	3.65[m]	3.65 m	Room width
Hd	0.5[m]	0.5 m	Diffuser inlet height
Ad	1.7[m ²]	1.7 m ²	Diffuser inlet area
As	0.0324[m ²]	0.0324 m ²	Source inlet area
Ao	0.04[m ²]	0.04 m ²	Outlet area

DEFINITIONS

Variables 1

- 1 In the **Definitions** toolbar, click  **Local Variables**.
- 2 In the **Settings** window for **Variables**, locate the **Variables** section.
- 3 In the table, enter the following settings:

Name	Expression	Unit	Description
Ms	$0.028[m^3/s]$	m^3/s	Volume flow rate at source
Md	$0.051[m^3/s]$	m^3/s	Volume flow rate at diffuser
Us	Ms/As	m/s	Source inlet velocity
Ud	Md/Ad	m/s	Diffuser inlet velocity
Tdiff	21[degC]	K	Diffuser air temperature
Tsource	45[degC]	K	Source air temperature
Tout	17[degC]	K	Outside temperature

GEOMETRY 1

Block 1 (blk1)

- 1 In the **Geometry** toolbar, click  **Block**.
- 2 In the **Settings** window for **Block**, locate the **Size and Shape** section.
- 3 In the **Width** text field, type D.
- 4 In the **Depth** text field, type W.
- 5 In the **Height** text field, type $2*H$.
- 6 Locate the **Position** section. In the **y** text field, type $-W/2$.
- 7 In the **z** text field, type $-H$.

Block 2 (blk2)

- 1 In the **Geometry** toolbar, click  **Block**.
- 2 In the **Settings** window for **Block**, locate the **Size and Shape** section.
- 3 In the **Width** text field, type $0.05[m]$.
- 4 In the **Height** text field, type $2*Hd$.
- 5 In the **Depth** text field, type Ad/Hd .
- 6 Locate the **Position** section. In the **x** text field, type $-0.05[m]$.
- 7 In the **y** text field, type $-Ad/Hd/2$.

8 In the **z** text field, type -Hd.



Union 1 (uni1)

- 1 In the **Geometry** toolbar, click  **Booleans and Partitions** and choose **Union**.
- 2 In the **Settings** window for **Union**, locate the **Union** section.
- 3 Clear the **Keep interior boundaries** checkbox.
- 4 Click in the **Graphics** window and then press Ctrl+A to select both objects.

Block 3 (blk3)

- 1 In the **Geometry** toolbar, click  **Block**.
- 2 In the **Settings** window for **Block**, locate the **Size and Shape** section.
- 3 In the **Width** text field, type 4[m].
- 4 In the **Depth** text field, type 4[m].
- 5 In the **Height** text field, type 4[m].
- 6 Locate the **Position** section. In the **x** text field, type -1[m].
- 7 In the **y** text field, type -2[m].
- 8 In the **z** text field, type -4[m].



Difference 1 (dif1)

- 1 In the **Geometry** toolbar, click  **Booleans and Partitions** and choose **Difference**.
- 2 In the **Settings** window for **Difference**, locate the **Difference** section.
- 3 Clear the **Keep interior boundaries** checkbox.
- 4 Select the object **uni1** only.
- 5 Click to select the  **Activate Selection** toggle button for **Objects to subtract**.
- 6 Select the object **blk3** only.

Block 4 (blk4)

- 1 In the **Geometry** toolbar, click  **Block**.
- 2 In the **Settings** window for **Block**, locate the **Size and Shape** section.
- 3 In the **Width** text field, type 3[m].
- 4 In the **Depth** text field, type 2[m].
- 5 In the **Height** text field, type 5[m].
- 6 Locate the **Position** section. In the **x** text field, type -0.2[m].
- 7 In the **y** text field, type -2[m].
- 8 In the **z** text field, type -1[m].



Difference 2 (dif2)

- 1 In the **Geometry** toolbar, click  **Booleans and Partitions** and choose **Difference**.
- 2 In the **Settings** window for **Difference**, locate the **Difference** section.
- 3 Clear the **Keep interior boundaries** checkbox.
- 4 Select the object **dif1** only.
- 5 Click to select the  **Activate Selection** toggle button for **Objects to subtract**.
- 6 Select the object **blk4** only.

Block 5 (blk5)

- 1 In the **Geometry** toolbar, click  **Block**.
- 2 In the **Settings** window for **Block**, locate the **Size and Shape** section.
- 3 In the **Width** text field, type $\sqrt{A_s}$.
- 4 In the **Depth** text field, type $\sqrt{A_s} / 2$.
- 5 In the **Height** text field, type $H/2$.
- 6 Locate the **Position** section. In the **x** text field, type $D/2 - \sqrt{A_s} / 2$.
- 7 In the **z** text field, type -0.05 [m].

Block 6 (blk6)

- 1 In the **Geometry** toolbar, click  **Block**.
- 2 In the **Settings** window for **Block**, locate the **Size and Shape** section.
- 3 In the **Width** text field, type $\sqrt{A_0}$.
- 4 In the **Depth** text field, type $\sqrt{A_0} / 2$.
- 5 In the **Height** text field, type 0.45 [m].
- 6 Locate the **Position** section. In the **x** text field, type $D/2 - \sqrt{A_0} / 2$.
- 7 In the **z** text field, type $H - 0.3$ [m].
- 8 In the **Geometry** toolbar, click  **Build All**.
- 9 Click the  **Zoom Extents** button in the **Graphics** toolbar.

Mesh Control Domains 1 (mcd1)

- 1 In the **Geometry** toolbar, click  **Virtual Operations** and choose **Mesh Control Domains**.

- 2 On the object **fin**, select Domains 2 and 5 only.

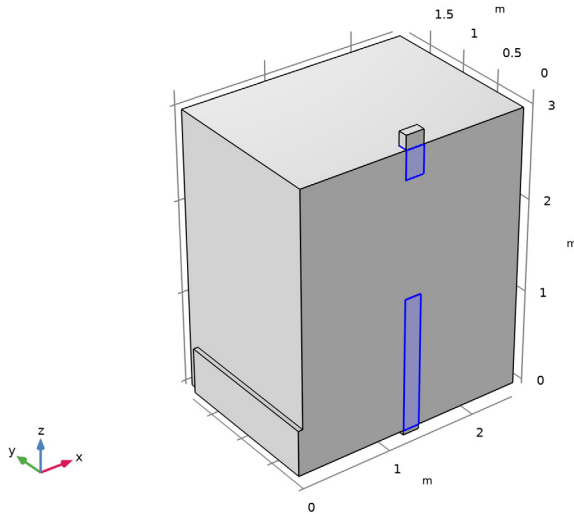

It might be easier to select the domains by using the **Selection List** window. To open this window, in the **Home** toolbar click **Windows** and choose **Selection List**. (If you are running the cross-platform desktop, you find **Windows** in the main menu.)



- 3 In the **Geometry** toolbar, click  **Build All**.
- 4 In the **Model Builder** window, collapse the **Geometry 1** node.

The model geometry is now complete and should look like [Figure 1](#).

ADD MATERIAL

- 1 In the **Materials** toolbar, click  **Add Material** to open the **Add Material** window.
- 2 Go to the **Add Material** window.
- 3 In the tree, select **Built-in > Air**.
- 4 Click the **Add to Component** button in the window toolbar.
- 5 In the **Materials** toolbar, click  **Add Material** to close the **Add Material** window.

TURBULENT FLOW, $k-\omega$ (SPF)

- 1 In the **Settings** window for **Turbulent Flow, $k-\omega$** , locate the **Physical Model** section.
- 2 Select the **Include gravity** checkbox.

3 Specify the \mathbf{r}_{ref} vector as

0	x
0	y
H+0.15[m]	z

Enable buoyancy-induced turbulence.

4 Select the **Include buoyancy-induced turbulence** checkbox.

Inlet 1

1 In the **Physics** toolbar, click  **Boundaries** and choose **Inlet**.

2 Select Boundary 13 only.

3 In the **Settings** window for **Inlet**, locate the **Velocity** section.

4 In the U_0 text field, type U_s .

5 Locate the **Turbulence Conditions** section. From the I_T list, choose **High (0.1)**.

The air probably enters through a grid. It is therefore appropriate to set a high inlet intensity and short length scale.

Inlet 2

1 In the **Physics** toolbar, click  **Boundaries** and choose **Inlet**.

2 Select Boundary 1 only.

3 In the **Settings** window for **Inlet**, locate the **Velocity** section.

4 In the U_0 text field, type U_d .

Outlet 1

1 In the **Physics** toolbar, click  **Boundaries** and choose **Outlet**.

2 Select Boundary 10 only.

3 In the **Settings** window for **Outlet**, locate the **Pressure Conditions** section.

4 Select the **Normal flow** checkbox.

Symmetry 1

1 In the **Physics** toolbar, click  **Boundaries** and choose **Symmetry**.

2 Select Boundary 2 only.

HEAT TRANSFER IN FLUIDS (HT)

In the **Physics** toolbar, click  **Boundaries** and choose **Symmetry**.

Select Boundary 2 only.

Temperature 1

- 1 In the **Physics** toolbar, click  **Boundaries** and choose **Temperature**.
- 2 Select Boundary 1 only.
- 3 In the **Settings** window for **Temperature**, locate the **Temperature** section.
- 4 In the T_0 text field, type T_{diff} .

Temperature 2

- 1 In the **Physics** toolbar, click  **Boundaries** and choose **Temperature**.
- 2 Select Boundary 13 only.
- 3 In the **Settings** window for **Temperature**, locate the **Temperature** section.
- 4 In the T_0 text field, type T_{source} .

Outflow 1

- 1 In the **Physics** toolbar, click  **Boundaries** and choose **Outflow**.
- 2 Select Boundary 10 only.

Heat Flux 1

- 1 In the **Physics** toolbar, click  **Boundaries** and choose **Heat Flux**.
- 2 In the **Settings** window for **Heat Flux**, locate the **Heat Flux** section.
- 3 From the **Flux type** list, choose **Convective heat flux**.
- 4 In the h text field, type $0.4 [W / (m^2 * K)]$.
- 5 In the T_{ext} text field, type T_{out} .
- 6 Select Boundaries 6–8 and 17 only.

MESH 1

In the **Model Builder** window, under **Component 1 (comp1)** right-click **Mesh 1** and choose **Edit Physics-Induced Sequence**.

Size

- 1 In the **Model Builder** window, under **Component 1 (comp1)** > **Mesh 1** click **Size**.
- 2 In the **Settings** window for **Size**, locate the **Element Size** section.
- 3 Click the **Custom** button.
- 4 Locate the **Element Size Parameters** section. In the **Minimum element size** text field, type 0.015.

Size 2

- 1 In the **Model Builder** window, click **Size 2**.

- 2 In the **Settings** window for **Size**, locate the **Geometric Entity Selection** section.
- 3 Click  **Clear Selection**.
- 4 Select Boundaries 9, 11, 12, and 14–16 only.
- 5 Locate the **Element Size** section. Click the **Custom** button.
- 6 Locate the **Element Size Parameters** section.
- 7 Select the **Maximum element size** checkbox. In the associated text field, type 0.015.

Size 1

- 1 In the **Model Builder** window, right-click **Free Tetrahedral 1** and choose **Size**.
- 2 In the **Settings** window for **Size**, locate the **Geometric Entity Selection** section.
- 3 From the **Geometric entity level** list, choose **Domain**.
- 4 Select Domains 2–5 only.

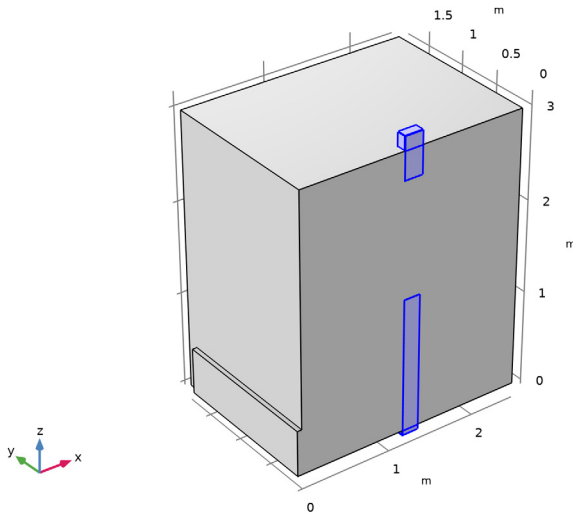

- 5 Locate the **Element Size** section. Click the **Custom** button.
- 6 Locate the **Element Size Parameters** section.
- 7 Select the **Maximum element growth rate** checkbox. In the associated text field, type 1.05.

Boundary Layer Properties 1

- 1 In the **Model Builder** window, expand the **Component 1 (comp1) > Mesh 1 > Boundary Layers 1** node, then click **Boundary Layer Properties 1**.

- 2 In the **Settings** window for **Boundary Layer Properties**, locate the **Layers** section.
- 3 In the **Thickness adjustment factor** text field, type 3.
- 4 In the **Number of layers** text field, type 5.
- 5 In the **Model Builder** window, right-click **Mesh 1** and choose **Build All**.

RESULTS

Large models may be easier to work with if the plots are updated on request only.

- 1 In the **Model Builder** window, click **Results**.
- 2 In the **Settings** window for **Results**, locate the **Update of Results** section.
- 3 Select the **Only plot when requested** checkbox.

STUDY 1

- 1 In the **Study** toolbar, click  **Compute**.

Proceed to reproduce [Figure 2](#).

RESULTS

Surface 1

- 1 In the **Model Builder** window, expand the **Wall Resolution (spf)** node, then click **Surface 1**.
- 2 In the **Settings** window for **Surface**, locate the **Coloring and Style** section.
- 3 From the **Coloring** list, choose **Uniform**.
- 4 From the **Color** list, choose **Gray**.
- 5 Click to expand the **Title** section. From the **Title type** list, choose **None**.

Streamline 1

- 1 In the **Model Builder** window, right-click **Wall Resolution (spf)** and choose **Streamline**.
- 2 In the **Settings** window for **Streamline**, locate the **Data** section.
- 3 From the **Dataset** list, choose **Study 1/Solution 1 (sol1)**.
- 4 Locate the **Streamline Positioning** section. From the **Positioning** list, choose **Uniform density**.
- 5 In the **Density level** text field, type 8.
- 6 Locate the **Coloring and Style** section. Find the **Line style** subsection. From the **Type** list, choose **Ribbon**.

Color Expression 1

- 1 Right-click **Streamline 1** and choose **Color Expression**.

- 2 In the **Settings** window for **Color Expression**, click **Replace Expression** in the upper-right corner of the **Expression** section. From the menu, choose **Component 1 (comp1) > Heat Transfer in Fluids > Temperature > T - Temperature - K**.
- 3 Locate the **Coloring and Style** section. From the **Color table** list, choose **ThermalDark**.
- 4 Click to expand the **Range** section. Select the **Manual color range** checkbox.
- 5 In the **Minimum** text field, type 293.
- 6 In the **Maximum** text field, type 300.



Streamline 1

- 1 In the **Model Builder** window, click **Streamline 1**.
- 2 In the **Settings** window for **Streamline**, click to expand the **Title** section.
- 3 From the **Title type** list, choose **Manual**.
- 4 In the **Title** text area, type Streamlines colored by temperature.

Streamlines

- 1 In the **Model Builder** window, under **Results** click **Wall Resolution (spf)**.
- 2 In the **Settings** window for **3D Plot Group**, type Streamlines in the **Label** text field.
- 3 Locate the **Plot Settings** section. From the **View** list, choose **New view**.
- 4 In the **Streamlines** toolbar, click  **Plot**.

RESULT TEMPLATES

- 1 In the **Results** toolbar, click  **Result Templates** to open the **Result Templates** window.
- 2 Go to the **Result Templates** window.
- 3 In the tree, select **Study 1/Solution 1 (sol1) > Heat Transfer in Fluids > Isothermal Contours (ht)**.
- 4 Click the **Add Result Template** button in the window toolbar.
- 5 In the **Results** toolbar, click  **Result Templates** to close the **Result Templates** window.

RESULTS

Isothermal Contours (ht)

Execute the following steps to reproduce [Figure 3](#).

- 1 In the **Settings** window for **3D Plot Group**, locate the **Plot Settings** section.
- 2 From the **View** list, choose **View 3D 2**.

Isosurface 1

- 1 In the **Model Builder** window, expand the **Isothermal Contours (ht)** node, then click **Isosurface 1**.
- 2 In the **Settings** window for **Isosurface**, locate the **Expression** section.
- 3 In the **Unit** field, type degC.
- 4 Locate the **Levels** section. From the **Entry method** list, choose **Levels**.
- 5 In the **Levels** text field, type 22 23 24 25 26.

The following steps will reproduce [Figure 4](#).

Table 1



- 1 In the **Results** toolbar, click  **Table**.
- 2 In the **Settings** window for **Table**, locate the **Data** section.
- 3 Click  **Import**.
- 4 Browse to the model's Application Libraries folder and double-click the file displacement_ventilation_exp.txt.

TABLE 1

- 1 Go to the **Table 1** window.
- 2 Click the right end of the **Display Table 1** split button in the window toolbar.
- 3 From the menu, choose **Table Graph**.

RESULTS

Table Graph 1

- 1 In the **Settings** window for **Table Graph**, locate the **Data** section.
- 2 From the **x-axis data** list, choose **Column 2**.
- 3 Locate the **Coloring and Style** section. Find the **Line style** subsection. From the **Line** list, choose **None**.
- 4 Find the **Line markers** subsection. From the **Marker** list, choose **Circle**.
- 5 Click to expand the **Legends** section. Select the **Show legends** checkbox.
- 6 From the **Legends** list, choose **Manual**.
- 7 In the table, enter the following settings:

Legends
Experiment

Cut Line 3D 1

- 1 In the **Results** toolbar, click  **Cut Line 3D**.
- 2 In the **Settings** window for **Cut Line 3D**, locate the **Line Data** section.
- 3 In row **Point 1**, set **x** to D/2.
- 4 In row **Point 2**, set **x** to D/2 and **z** to H.

ID Plot Group 7

- 1 In the **Model Builder** window, under **Results** click **ID Plot Group 7**.
- 2 In the **Settings** window for **ID Plot Group**, locate the **Data** section.
- 3 From the **Dataset** list, choose **Cut Line 3D 1**.

Line Graph 1

- 1 Right-click **ID Plot Group 7** and choose **Line Graph**.
- 2 In the **Settings** window for **Line Graph**, locate the **y-Axis Data** section.
- 3 In the **Expression** text field, type z.
- 4 Locate the **x-Axis Data** section. From the **Parameter** list, choose **Expression**.
- 5 In the **Expression** text field, type T.
- 6 In the **Unit** field, type degC.
- 7 Click to expand the **Coloring and Style** section. From the **Width** list, choose **3**.
- 8 Click to expand the **Legends** section. Select the **Show legends** checkbox.
- 9 From the **Legends** list, choose **Manual**.
- 10 In the table, enter the following settings:

Legends

Model

ID Plot Group 7

- 1 In the **Model Builder** window, click **ID Plot Group 7**.
- 2 In the **Settings** window for **ID Plot Group**, click to expand the **Title** section.
- 3 From the **Title type** list, choose **None**.
- 4 Locate the **Plot Settings** section.
- 5 Select the **x-axis label** checkbox. In the associated text field, type T [degC].
- 6 Select the **y-axis label** checkbox. In the associated text field, type z [m].
- 7 Locate the **Axis** section. Select the **Manual axis limits** checkbox.
- 8 In the **x minimum** text field, type 0.

- 9 In the **x maximum** text field, type 46.
- 10 In the **y minimum** text field, type 0.
- 11 In the **y maximum** text field, type 3.
- 12 In the **ID Plot Group 7** toolbar, click  **Plot**.