

Model created in COMSOL Multiphysics 6.4

Turbulent 3D Flow Past a Cylinder



Introduction

This model studies the difference between the SST and SST-SAS (Scale Adaptive Simulation) turbulence models for flow around a cylinder.

Fluid flow past a cylinder is a common test case for computational fluid dynamics. As the Reynolds number increases, the flow transitions from laminar to turbulent with a cascade of vortices in the downstream wake of the cylinder. A common method to handle the flow instabilities that occur is to use some kind of turbulence model that effectively increases the viscosity in regions where such small vortices would occur, without resolving the turbulence structures in detail. The *Reynolds-averaged Navier–Stokes* models (RANS) constitute a family of such turbulence models that allow a quite accurate representation of the general turbulent flow by smoothing out the smaller structures. Another family of turbulence models, *large eddy simulations* (LES), uses a different approach and is capable of resolving the vortices to a larger extent at the cost of a finer mesh and a stricter criterion for the time stepping.

The SST-SAS model introduces the von Kármán length scale, through an extra source contribution in the equation for the turbulence-specific dissipation rate. This makes it possible for SST-SAS to resolve smaller turbulence structures than the original SST model, while still being in the same family of RANS models. The advantage is a more detailed resolution of the turbulence structures on the same mesh in transient simulations.

The von Kármán length scale is given by the equation

$$L_{\text{vk}} = \kappa \sqrt{\frac{\frac{\partial U_i \partial U_j}{\partial x_j \partial x_i}}{\frac{\partial^2 U_i \partial^2 U_i}{\partial x_j^2 \partial x_k^2}}} \quad (1)$$

As can be seen, the expression for the von Kármán length scale includes the second derivatives of the velocity field. The additional source term for the specific dissipation rate can be expressed as

$$Q_{\text{SAS}} = \max \left[\rho \xi_{\text{SAS}} \kappa S^2 \left(\frac{L}{L_{\text{vk}}} \right)^2 - C_{\text{SAS}} \frac{2\rho k}{\sigma_{\text{SAS}}} \max \left(\frac{1}{\omega^2} \frac{\partial \omega}{\partial x_i} \frac{\partial \omega}{\partial x_i}, \frac{1}{k^2} \frac{\partial k}{\partial x_i} \frac{\partial k}{\partial x_i} \right), 0 \right]$$

where ρ is the density, ξ_{SAS} , κ , C_{SAS} , and σ_{SAS} are model parameters, and L is the turbulence length scale.

This model compares the resolved turbulence scales in two time-dependent simulations with the SST and SST-SAS models. It also investigates the frequency of vortex shedding from the cylinder by evaluating the integral of the lift force on the cylinder.

The frequency of shedding has been experimentally determined as a function of the Strouhal number, defined as

$$\text{St}(\text{Re}) = \frac{fD}{U}$$

where f is the shedding frequency. The Strouhal number depends on the Reynolds number and is approximately 0.21 around $\text{Re} = 4000$.

Model Definition

The geometry consists of a cylinder of diameter D and length $2D$ with the axis parallel to the y -axis, and placed at $(0, 0, 0)$. The surrounding box is $30D$ long and $20D$ high to avoid any influence of the external boundaries. A smaller box of height $3D$ and width $10D$ is placed around the cylinder to define a domain with a refined mesh. The geometry is shown in [Figure 1](#).

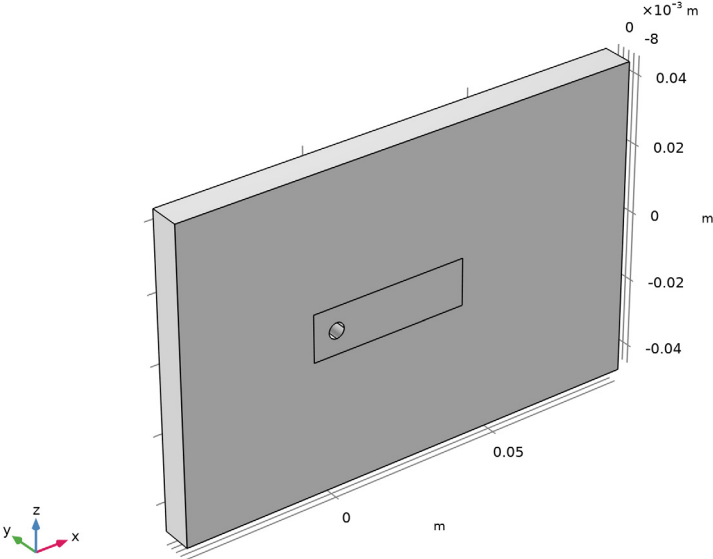

Figure 1: Geometry of the cylinder with the mesh refinement box.

The inlet Mach number is set to 0.05 and the outlet gauge pressure is set to 0 Pa. A periodic condition is used on the sides orthogonal to the cylinder.

First, a stationary study is run with the SST model on a coarse mesh to give good initial values for the transient simulations. Subsequently, two studies are run on a finer mesh with the SST and SST-SAS models in order to compare the two models. The mesh size downstream of the cylinder is chosen to be $D/15$ to be able to resolve some of the turbulence structures. The mesh can be seen in [Figure 2](#). Crosswind diffusion stabilization is turned off for both studies to further enhance the transversal turbulent flow structures.

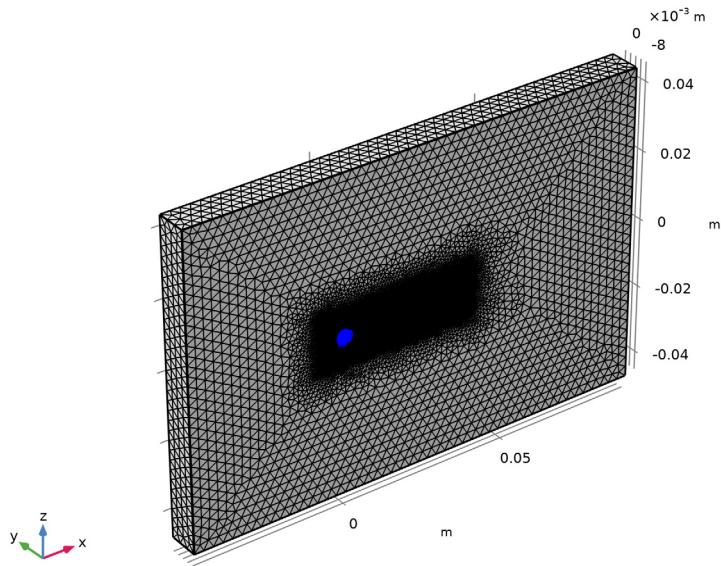

Figure 2: Mesh for the time-dependent studies. The mesh is refined around the cylinder walls and downstream to give a more detailed representation of the turbulence structures.

Results and Discussion

Figure 3 shows the Q-criterion plot for the last time step computed with the SST turbulence model.

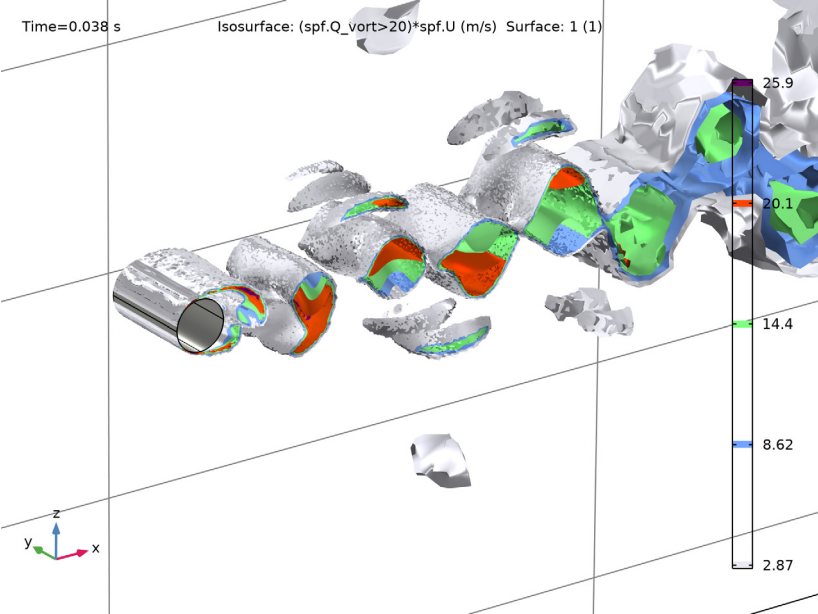

Figure 3: Visualization of the Q-criterion for the SST turbulence model. Note that the shed vortices have a two-dimensional form.

Figure 4 shows a similar plot for the SST-SAS model. Note the difference in the transversal structures, which is more pronounced in the SST-SAS model due to the scale-adaptive contributions in the specific-dissipation-rate equation.

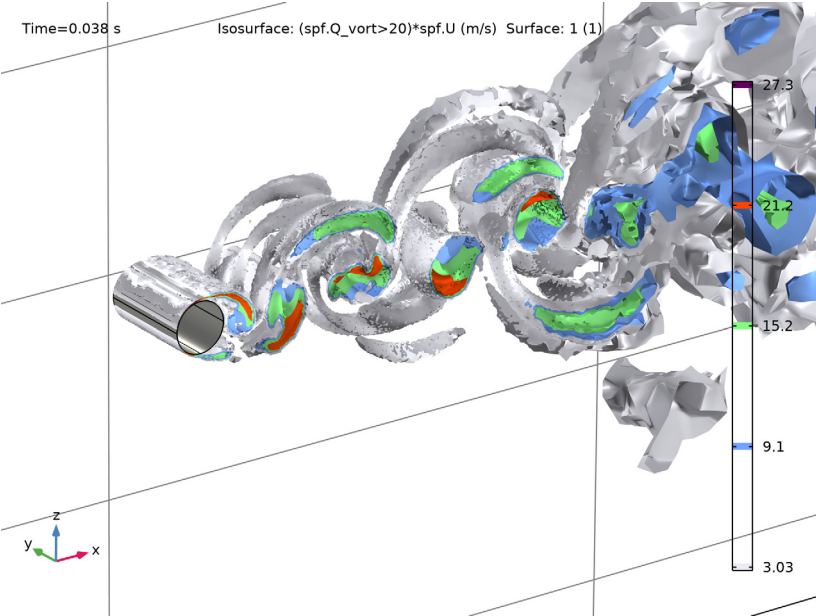

Figure 4: Visualization of the Q -criterion for the SST-SAS turbulence model. Note the more pronounced three-dimensional turbulence structures.

Figure 5 shows the time-dependent integrated z -component of the forces on the cylinder for the two different models. Note the difference in the periods.

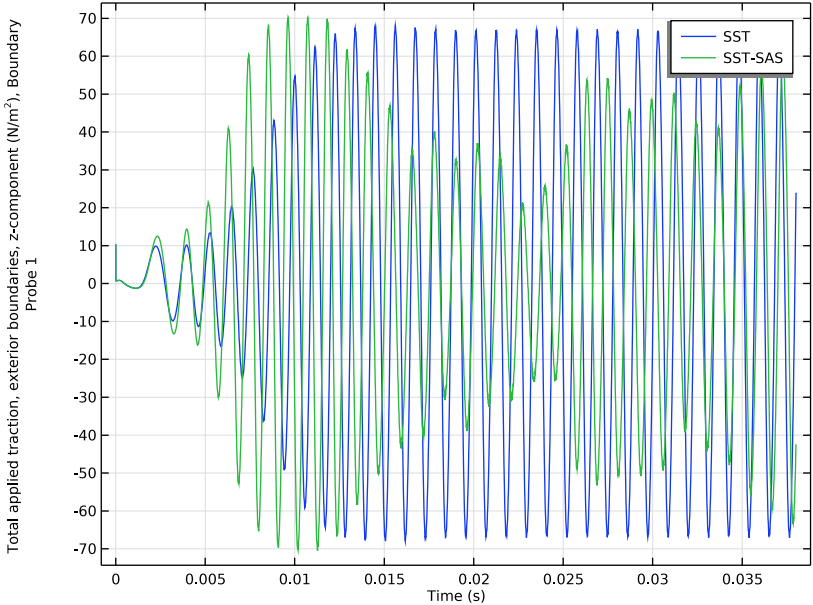

Figure 5: Time-dependent lift forces on the cylinder for the SST and SST-SAS models. Note the differences in startup behavior and frequency.

Figure 6 shows the Fourier-transformed results.

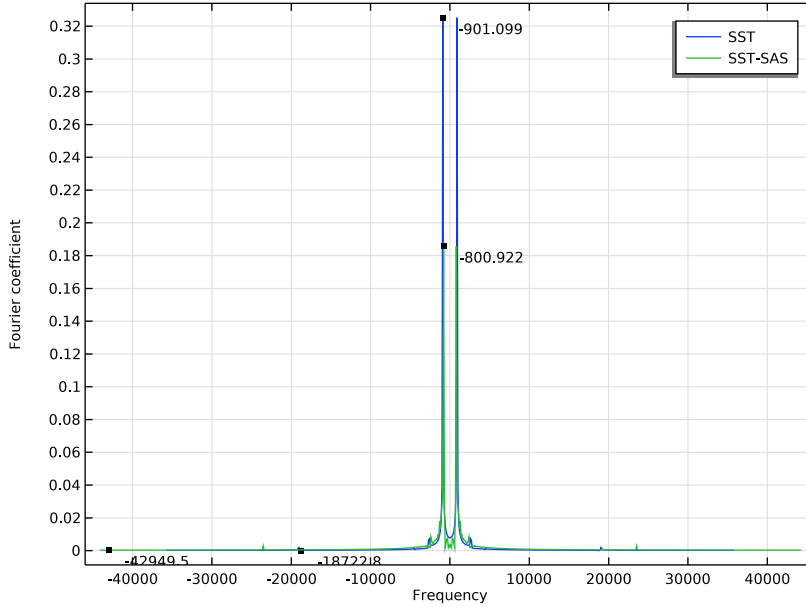

Figure 6: Discrete Fourier Transform (DFT) of the time-dependent lift forces exerted on the cylinder. A window from 0.013 s to 0.043 s has been used to remove the frequency distribution during the initial transient before stable shedding occurs.

The SST-SAS model result lies close to the value calculated from the Strouhal number, which is in the vicinity of 800 Hz.

Reference

I. F.R. Menter, A. Garbaruk, P. Smirnov, D. Cokljat, and F. Mathey, “Progress in Hybrid RANS-LES Modelling: Papers Contributed to the 3rd Symposium on Hybrid RANS-LES Methods, Gdansk, Poland, June 2009,” pp. 235–246, *Springer*, 2010.

Application Library path: CFD_Module/Single-Phase_Flow/
cylinder_flow_turbulent



Modeling Instructions

From the **File** menu, choose **New**.

NEW

In the **New** window, click  **Model Wizard**.

MODEL WIZARD

- 1 In the **Model Wizard** window, click  **3D**.
- 2 In the **Select Physics** tree, select **Fluid Flow > Single-Phase Flow > Turbulent Flow > Turbulent Flow, SST (spf)**.
- 3 Click **Add**.
- 4 Click  **Study**.
- 5 In the **Select Study** tree, select **Preset Studies for Selected Physics Interfaces > Stationary with Initialization**.
- 6 Click  **Done**.

Add the model parameters to the global parameters list.

GLOBAL DEFINITIONS

Parameters 1

- 1 In the **Model Builder** window, under **Global Definitions** click **Parameters 1**.
- 2 In the **Settings** window for **Parameters**, locate the **Parameters** section.
- 3 In the table, enter the following settings:

Name	Expression	Value	Description
D	4.548[mm]	0.004548 m	Cylinder diameter
Uin	0.05*343[m/s]	17.15 m/s	Inlet velocity
rhof	1[kg/m^3]	1 kg/m ³	Fluid density
visc	2e-5[Pa*s]	2E-5 Pa*s	Fluid kinematic viscosity
Re	Uin*D*rhof/visc	3899.9	Reynolds number

Create the geometry of a cylinder enclosed in a box.

GEOMETRY I

Work Plane 1 (wp1)

- 1 In the **Geometry** toolbar, click  **Work Plane**.
- 2 In the **Settings** window for **Work Plane**, locate the **Plane Definition** section.
- 3 From the **Plane** list, choose **xz-plane**.

Work Plane 1 (wp1) > Plane Geometry

In the **Model Builder** window, click **Plane Geometry**.



Work Plane 1 (wp1) > Circle 1 (c1)

- 1 In the **Work Plane** toolbar, click  **Circle**.
- 2 In the **Settings** window for **Circle**, locate the **Size and Shape** section.
- 3 In the **Radius** text field, type $D/2$.



Work Plane 1 (wp1) > Rectangle 1 (r1)

- 1 In the **Work Plane** toolbar, click  **Rectangle**.
- 2 In the **Settings** window for **Rectangle**, locate the **Size and Shape** section.
- 3 In the **Width** text field, type $30*D$.
- 4 In the **Height** text field, type $20*D$.
- 5 Locate the **Position** section. In the **xw** text field, type $-10*D$.
- 6 In the **yw** text field, type $-10*D$.

Work Plane 1 (wp1) > Rectangle 2 (r2)

- 1 In the **Work Plane** toolbar, click  **Rectangle**.
- 2 In the **Settings** window for **Rectangle**, locate the **Size and Shape** section.
- 3 In the **Width** text field, type $10*D$.
- 4 In the **Height** text field, type $3*D$.
- 5 Locate the **Position** section. In the **xw** text field, type $-1.5*D$.
- 6 In the **yw** text field, type $-1.5*D$.
- 7 In the **Work Plane** toolbar, click  **Build All**.

Work Plane 1 (wp1) > Difference 1 (dif1)

- 1 In the **Work Plane** toolbar, click  **Booleans and Partitions** and choose **Difference**.
- 2 Select the objects **r1** and **r2** only.
- 3 In the **Settings** window for **Difference**, locate the **Difference** section.
- 4 Click to select the  **Activate Selection** toggle button for **Objects to subtract**.

- 5 Select the object **cl** only.
- 6 In the **Work Plane** toolbar, click  **Build All**.

Extrude 1 (ext1)

- 1 In the **Model Builder** window, under **Component 1 (comp1)** > **Geometry 1** right-click **Work Plane 1 (wp1)** and choose **Extrude**.
- 2 In the **Settings** window for **Extrude**, locate the **Distances** section.
- 3 In the table, enter the following settings:



Distances (m)
2*D

- 4 Click  **Build Selected**.

Form Union (fin)

- 1 In the **Model Builder** window, click **Form Union (fin)**.
- 2 In the **Settings** window for **Form Union/Assembly**, click  **Build Selected**.

Mesh Control Domains 1 (mcd1)

- 1 In the **Geometry** toolbar, click  **Virtual Operations** and choose **Mesh Control Domains**.
- 2 On the object **fin**, select Domain 2 only.
- 3 In the **Geometry** toolbar, click  **Build All**.

Add a blank material and use the density and viscosity from the previously defined parameters.

MATERIALS

Fluid

- 1 In the **Model Builder** window, under **Component 1 (comp1)** right-click **Materials** and choose **Blank Material**.
- 2 In the **Settings** window for **Material**, type Fluid in the **Label** text field.
- 3 Locate the **Material Contents** section. In the table, enter the following settings:

Property	Variable	Value	Unit	Property group
Density	rho	rhof	kg/m ³	Basic
Dynamic viscosity	mu	visc	Pa·s	Basic

Define the boundary conditions for the flow.

TURBULENT FLOW, SST (SPF)

Inlet 1

- 1 In the **Physics** toolbar, click  **Boundaries** and choose **Inlet**.
- 2 Select Boundary 1 only.
- 3 In the **Settings** window for **Inlet**, locate the **Velocity** section.
- 4 In the U_0 text field, type U_{in} .
- 5 Locate the **Turbulence Conditions** section. From the L_T list, choose **User defined**.
- 6 In the text field, type $0.1 * D$.

Outlet 1

- 1 In the **Physics** toolbar, click  **Boundaries** and choose **Outlet**.
- 2 Select Boundary 10 only.

Wall 2

- 1 In the **Physics** toolbar, click  **Boundaries** and choose **Wall**.
- 2 Select Boundaries 3 and 4 only.
- 3 In the **Settings** window for **Wall**, locate the **Boundary Condition** section.
- 4 From the **Wall condition** list, choose **Slip**.

Periodic Flow Condition 1

- 1 In the **Physics** toolbar, click  **Boundaries** and choose **Periodic Flow Condition**.
- 2 Select Boundaries 2 and 5 only.

Change the mesh settings to coarser and run a stationary solution just to get good initial values for the transient models. A coarse mesh leads to some inherent diffusion that stabilizes the solution. With this mesh the flow pattern is clearly not resolved, but for such problems, a stationary solution will not exist when using a properly refined mesh.

MESH 1

- 1 In the **Model Builder** window, under **Component 1 (comp1)** click **Mesh 1**.
- 2 In the **Settings** window for **Mesh**, locate the **Physics-Controlled Mesh** section.
- 3 From the **Element size** list, choose **Coarser**.

STUDY 1





In the **Study** toolbar, click  **Compute**.

Add a boundary probe that integrates the z-component of the fluid forces exerted on the cylinder. This will make it possible to analyze the vortex-shedding frequency. The

advantage of using a probe here is that the integral will be saved in each time step. Hence, you get a good resolution of the desired curve without having to store the results in the entire mesh for each time step.

DEFINITIONS

Boundary Probe 1 (bnd1)

- 1 In the **Definitions** toolbar, click  **Probes** and choose **Boundary Probe**.
- 2 In the **Settings** window for **Boundary Probe**, locate the **Source Selection** section.
- 3 Click  **Clear Selection**.
- 4 Click the  **Select Box** button in the **Graphics** toolbar.
- 5 Select Boundaries 6–9 only.
- 6 Locate the **Expression** section. In the **Expression** text field, type `spf.T_trac2`.
- 7 Click to expand the **Table and Window Settings** section. From the **Output table** list, choose **New table**.
- 8 Click  **Add Table**.

To improve the accuracy of the SST and the SST-SAS turbulence models, disable **Crosswind diffusion stabilization** in the physics interface and enable the **Limit small time steps effect on stabilization time scale**.

TURBULENT FLOW, SST (SPF)

- 1 Click the  **Show More Options** button in the **Model Builder** toolbar.
- 2 In the **Show More Options** dialog, select **Physics > Stabilization** in the tree.
- 3 In the tree, select the checkbox for the node **Physics > Stabilization**.
- 4 Click **OK**.
- 5 In the **Model Builder** window, under **Component 1 (comp1)** click **Turbulent Flow, SST (spf)**.
- 6 In the **Settings** window for **Turbulent Flow, SST**, click to expand the **Consistent Stabilization** section.
- 7 Find the **Navier–Stokes equations** subsection. Clear the **Crosswind diffusion** checkbox.
- 8 Clear the **Use dynamic subgrid time scale** checkbox.
- 9 Select the **Limit small time steps effect on stabilization time scale** checkbox.

Add a new mesh and change the default settings so that the boundary layers are better resolved, and make a finer mesh downstream of the cylinder.

MESH 2

- 1 In the **Mesh** toolbar, click **Add Mesh** and choose **Add Mesh**.
- 2 In the **Settings** window for **Mesh**, locate the **Sequence Type** section.
- 3 From the list, choose **User-controlled mesh**.

Size

- 1 In the **Model Builder** window, under **Component 1 (compl) > Meshes > Mesh 2** click **Size**.
- 2 In the **Settings** window for **Size**, locate the **Element Size Parameters** section.
- 3 In the **Maximum element size** text field, type 0.006.
- 4 Locate the **Element Size** section. Click the **Predefined** button.
- 5 From the **Predefined** list, choose **Coarse**.
- 6 Locate the **Element Size Parameters** section. In the **Maximum element size** text field, type 0.006.

Size 1

- 1 In the **Model Builder** window, click **Size 1**.
- 2 In the **Settings** window for **Size**, locate the **Element Size** section.
- 3 Click the **Predefined** button.
- 4 From the **Predefined** list, choose **Coarse**.

Size 2

- 1 In the **Model Builder** window, click **Size 2**.
- 2 In the **Settings** window for **Size**, locate the **Geometric Entity Selection** section.
- 3 From the **Geometric entity level** list, choose **Domain**.
- 4 Select Domain 2 only.
- 5 Locate the **Element Size Parameters** section. In the **Maximum element size** text field, type D/15.
- 6 Clear the **Minimum element size** checkbox.
- 7 Clear the **Maximum element growth rate** checkbox.
- 8 Clear the **Curvature factor** checkbox.
- 9 Clear the **Resolution of narrow regions** checkbox.



Boundary Layer Properties 1

- 1 In the **Model Builder** window, expand the **Boundary Layers 1** node, then click **Boundary Layer Properties 1**.
- 2 In the **Settings** window for **Boundary Layer Properties**, locate the **Layers** section.

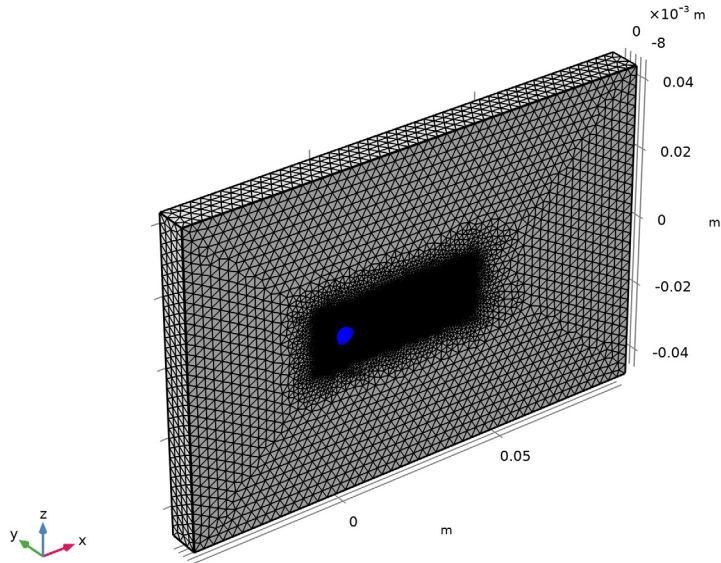
- 3 In the **Number of layers** text field, type 12.
- 4 In the **Thickness adjustment factor** text field, type 1.05.
- 5 Click  **Build All**.



ADD STUDY

- 1 In the **Home** toolbar, click  **Windows** and choose **Add Study**.
- 2 Go to the **Add Study** window.
- 3 Find the **Studies** subsection. In the **Select Study** tree, select **Preset Studies for Selected Physics Interfaces > Time Dependent with Initialization**.
- 4 Click the **Add Study** button in the window toolbar.
- 5 In the **Home** toolbar, click  **Add Study** to close the **Add Study** window.

STUDY 2

Solution 3 (sol3)

- 1 In the **Model Builder** window, expand the **Study 2** node.
- 2 Right-click **Study 2** and choose **Show Default Solver**.

Step 1: Wall Distance Initialization

- 1 In the **Model Builder** window, expand the **Solution 3 (sol3)** node, then click **Study 2 > Step 1: Wall Distance Initialization**.
- 2 In the **Settings** window for **Wall Distance Initialization**, click to expand the **Values of Dependent Variables** section.
- 3 Find the **Values of variables not solved for** subsection. From the **Settings** list, choose **User controlled**.
- 4 From the **Method** list, choose **Solution**.
- 5 From the **Study** list, choose **Study 1, Stationary**.

Step 2: Time Dependent

- 1 In the **Model Builder** window, click **Step 2: Time Dependent**.
- 2 In the **Settings** window for **Time Dependent**, locate the **Study Settings** section.
- 3 In the **Output times** text field, type range (0,5e-3,10e-3) range (13e-3,5e-3,40e-3).
- 4 In the **Study** toolbar, click  **Compute**.

Create a plot of the Q-criterion to visualize the turbulent structures.

RESULTS

Q-criterion

- 1 In the **Results** toolbar, click  **3D Plot Group**.
- 2 In the **Settings** window for **3D Plot Group**, locate the **Data** section.
- 3 From the **Dataset** list, choose **Study 2/Solution 3 (sol3)**.
- 4 In the **Label** text field, type Q-criterion.

Isosurface 1

- 1 Right-click **Q-criterion** and choose **Isosurface**.
Set the threshold for the Q-criterion to $Q > 20$ to isolate the downstream wake structures and avoid plot contamination from the inlet.
- 2 In the **Settings** window for **Isosurface**, locate the **Expression** section.
- 3 In the **Expression** text field, type $(spf.Q_vort > 20) * spf.U$.
- 4 Locate the **Coloring and Style** section. From the **Color table** list, choose **Prism**.
- 5 In the **Q-criterion** toolbar, click  **Plot**.



Surface 1

- 1 In the **Model Builder** window, right-click **Q-criterion** and choose **Surface**.
- 2 In the **Settings** window for **Surface**, locate the **Expression** section.
- 3 In the **Expression** text field, type 1.

Material Appearance 1

- 1 Right-click **Surface 1** and choose **Material Appearance**.
- 2 In the **Settings** window for **Material Appearance**, locate the **Appearance** section.
- 3 From the **Appearance** list, choose **Custom**.
- 4 From the **Material type** list, choose **Steel**.

Selection 1

- 1 In the **Model Builder** window, right-click **Surface 1** and choose **Selection**.
- 2 Click the  **Select Box** button in the **Graphics** toolbar.
- 3 Select Boundaries 6–9 only.
- 4 In the **Q-criterion** toolbar, click  **Plot**.

Enable the **Include scale-adaptive simulations** option in the turbulent flow interface to activate the SST-SAS model.

TURBULENT FLOW, SST (SPF)

- 1 In the **Model Builder** window, under **Component 1 (comp1)** click **Turbulent Flow, SST (spf)**.
- 2 In the **Settings** window for **Turbulent Flow, SST**, locate the **Turbulence** section.
- 3 Select the **Include scale-adaptive simulations** checkbox.



Add another probe table for the SST-SAS study. This makes it easier to compare the results afterward.

DEFINITIONS

Boundary Probe 1 (bnd1)

- 1 In the **Model Builder** window, under **Component 1 (comp1)** > **Definitions** click **Boundary Probe 1 (bnd1)**.
- 2 In the **Settings** window for **Boundary Probe**, click to expand the **Table and Window Settings** section.
- 3 Click  **Add Table**.

ADD STUDY

- 1 In the **Home** toolbar, click  **Windows** and choose **Add Study**.
- 2 Go to the **Add Study** window.
- 3 Find the **Studies** subsection. In the **Select Study** tree, select **Preset Studies for Selected Physics Interfaces > Time Dependent with Initialization**.
- 4 Click the **Add Study** button in the window toolbar.
- 5 In the **Home** toolbar, click  **Add Study** to close the **Add Study** window.

STUDY 3

Solution 5 (sol5)

- 1 In the **Study** toolbar, click  **Show Default Solver**.
- 2 In the **Model Builder** window, collapse the **Solution 5 (sol5)** node.

Step 1: Wall Distance Initialization

- 1 In the **Model Builder** window, expand the **Solution 5 (sol5)** node, then click **Study 3 > Step 1: Wall Distance Initialization**.
- 2 In the **Settings** window for **Wall Distance Initialization**, click to expand the **Values of Dependent Variables** section.
- 3 Find the **Values of variables not solved for** subsection. From the **Settings** list, choose **User controlled**.
- 4 From the **Method** list, choose **Solution**.
- 5 From the **Study** list, choose **Study 1, Stationary**.

Step 2: Time Dependent

- 1 In the **Model Builder** window, click **Step 2: Time Dependent**.
- 2 In the **Settings** window for **Time Dependent**, locate the **Study Settings** section.
- 3 In the **Output times** text field, type range (0,5e-3,10e-3) range (13e-3,5e-3,40e-3).
- 4 In the **Study** toolbar, click  **Compute**.

RESULTS

Q-criterion 1

- 1 In the **Model Builder** window, right-click **Q-criterion** and choose **Duplicate**.
- 2 In the **Settings** window for **3D Plot Group**, locate the **Data** section.
- 3 From the **Dataset** list, choose **Probe Solution 5 (sol5)**.

4 In the **Q-criterion 1** toolbar, click  **Plot**.

Inspect the probe plot to see the time-dependent vertical forces acting on the cylinder.

Probe Table Graph 1

- 1 In the **Model Builder** window, expand the **Probe Plot Group 4** node, then click **Probe Table Graph 1**.
- 2 In the **Settings** window for **Table Graph**, click to expand the **Legends** section.
- 3 From the **Legends** list, choose **Manual**.
- 4 In the table, enter the following settings:

Legends

SST

Probe Table Graph 2

- 1 In the **Model Builder** window, click **Probe Table Graph 2**.
- 2 In the **Settings** window for **Table Graph**, locate the **Legends** section.
- 3 From the **Legends** list, choose **Manual**.
- 4 In the table, enter the following settings:

Legends

SST-SAS

Duplicate the probe plot and perform a DFT to analyze the frequency of the vortex-shedding. Since the vortex shedding is a bit unstable to begin with, remove the first part of the data series by manually setting the x-axis.

Probe Plot Group FFT



- 1 In the **Model Builder** window, right-click **Probe Plot Group 4** and choose **Duplicate**.
- 2 In the **Settings** window for **ID Plot Group**, type Probe Plot Group FFT in the **Label** text field.

Probe Table Graph 1

- 1 In the **Model Builder** window, expand the **Probe Plot Group FFT** node, then click **Probe Table Graph 1**.
- 2 In the **Settings** window for **Table Graph**, locate the **Data** section.
- 3 From the **Transformation** list, choose **Discrete Fourier transform**.
- 4 In the **Model Builder** window, click **Probe Table Graph 1**.

- 5 Click to expand the **Preprocessing** section. Find the **x-axis column** subsection. From the **Range** list, choose **Manual**.
- 6 In the **x minimum** text field, type 0.1.
- 7 In the **x minimum** text field, type 0.013.
- 8 In the **x maximum** text field, type 0.023.
- 9 In the **Probe Plot Group FFT** toolbar, click  **Plot**.

Probe Table Graph 2

- 1 In the **Model Builder** window, click **Probe Table Graph 2**.
- 2 In the **Settings** window for **Table Graph**, locate the **Data** section.
- 3 From the **Transformation** list, choose **Discrete Fourier transform**.
- 4 In the **Probe Plot Group FFT** toolbar, click  **Plot**.
- 5 In the **Model Builder** window, click **Probe Table Graph 2**.
- 6 Click to expand the **Preprocessing** section. Find the **x-axis column** subsection. From the **Range** list, choose **Manual**.
- 7 In the **x minimum** text field, type 0.1.
- 8 In the **x minimum** text field, type 0.013.
- 9 In the **x maximum** text field, type 0.023.
- 10 In the **Probe Plot Group FFT** toolbar, click  **Plot**.

Graph Marker 1

- 1 In the **Model Builder** window, right-click **Probe Table Graph 1** and choose **Graph Marker**.
- 2 In the **Settings** window for **Graph Marker**, locate the **Text Format** section.
- 3 Clear the **Show y-coordinate** checkbox.
- 4 Select the **Show x-coordinate** checkbox.

Graph Marker 2

Right-click **Graph Marker 1** and choose **Duplicate**.

- 1 Drag and drop **Graph Marker 2** on **Probe Table Graph 2**.
- 2 In the **Probe Plot Group FFT** toolbar, click  **Plot**.