



Model created in COMSOL Multiphysics 6.4

Laminar Flow in a Baffled Stirred Mixer

Introduction

This exercise exemplifies the use of the rotating machinery features in the CFD Module. The Rotating Machinery interfaces allow you to model moving rotating parts in, for example, stirred tanks, mixers, and pumps.

The Rotating Machinery framework formulates the Navier–Stokes equations in a rotating coordinate system. Parts that are not rotated are expressed in the fixed spatial coordinate system. The rotating and fixed parts need to be coupled together by an identity pair, where a flux continuity boundary condition is applied.

You can use the rotating machinery predefined setup in cases where it is possible to divide the modeled device into rotationally invariant geometries. The desired operation can be, for example, to rotate an impeller in a baffled tank. This is exemplified in [Figure 1](#), where the impeller rotates from position 1 to 2 (in clockwise direction). The first step is to divide the geometry into two parts that are both rotationally invariant, as shown in Step 1a. The second step is to specify the parts to model using a rotating frame and the ones to model using a fixed frame (Step 1b). COMSOL Multiphysics automatically handles the coordinate transformation and the joining of the fixed and moving parts (Step 2a).

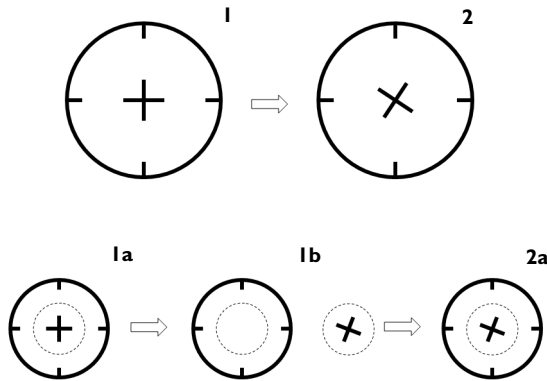

Figure 1: The modeling procedure in the Rotating Machinery setup in COMSOL Multiphysics.

Model Definition

The model you treat in this example is that of a baffled stirred mixer. [Figure 2](#) shows the modeled geometry. The impeller rotates counterclockwise at a speed of 1 RPM, and the fluid in the mixer is water.

The model equations are the Navier–Stokes equations formulated in a rotating frame in the inner domain and in fixed coordinates in the outer one.

At the mixer’s fixed walls, no slip boundary conditions apply. The boundary condition on the rotating impeller are set to rotate with the same velocity as the no slip counterclockwise rotation conditions. This is done automatically when the **Translational Velocity** in the **Wall Movement** section of the Wall feature is set to **Automatic from Frame**.

The implementation, applying the predefined set up for the Rotating Machinery, Laminar Flow interface, is straightforward. First you draw the geometry using two separate non-overlapping domains for the fixed and rotating parts. The next step is to form an assembly and create an identity pair, which makes it possible to treat the two domains as separate parts. You then specify which part uses a rotating frame. Once you have done this, you can proceed to the usual steps of setting the fluid properties and the boundary conditions, and finally to meshing and solving the problem.

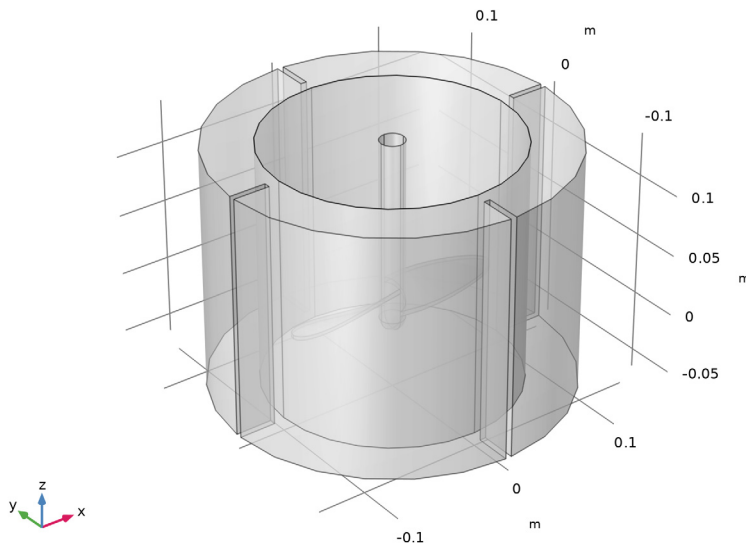

Figure 2: Geometry of the baffled stirred mixer. The inner domain is represented by a rotating frame and the outer domain by a fixed (spatial) frame.

Results and Discussion

Figure 3 shows the shear rate at the last time step, when the mixer has rotated with full speed for 60 seconds. The shear rate can be important for example when the mixture consists of living cells which are sensitive to too high shear rates.

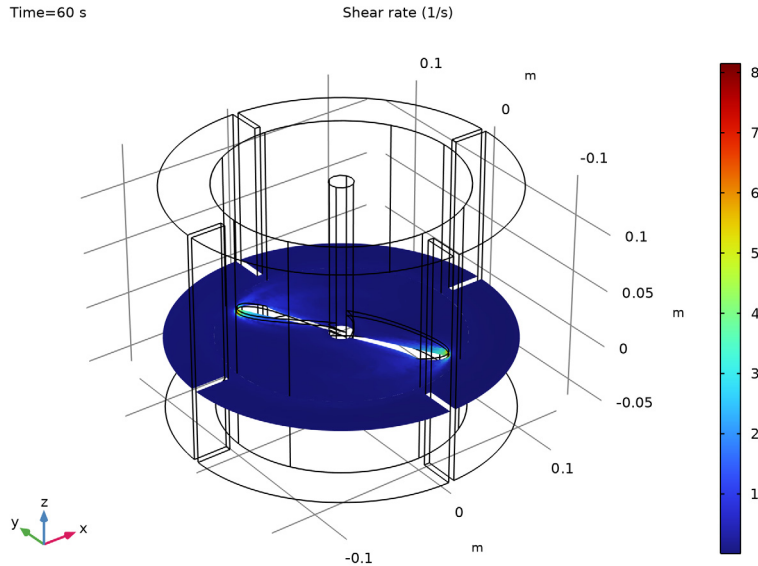

Figure 3: The shear rate after 6 seconds. The plot shows that the shear rate reaches its maximum value at the tip of the impeller blades.

In Figure 3, you can clearly see that the shear rate is highest where the impeller speed is highest, which is expected. If the shear rate is too high, consider to redesign the impeller with sharp leading and trailing edges.

Figure 4 shows the velocity field in the yz -plane at $t = 55$ s. It is clear that the impeller is creating a downward flow where the blades pass through the fluid.

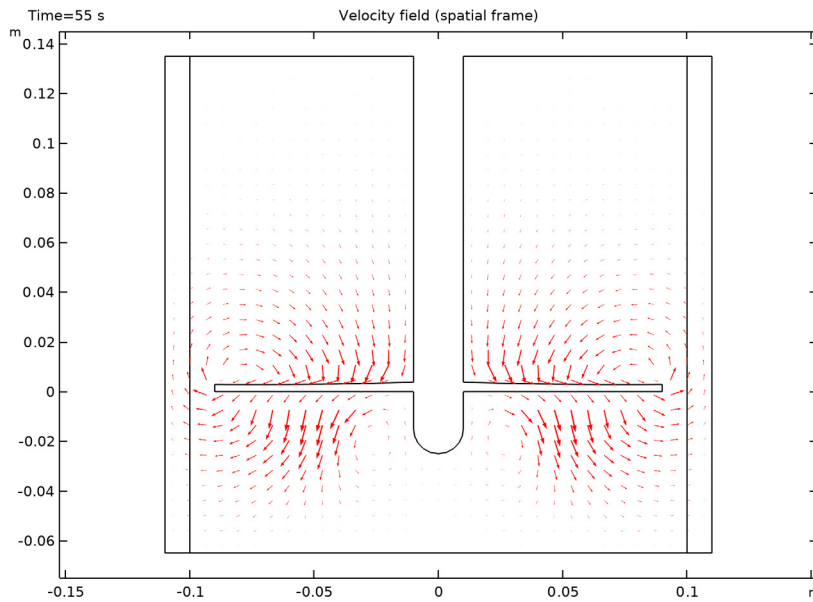

Figure 4: Velocity field in the yz -plane at $t = 55$ s.

You can use the **Player** button (under **3D Plot Group 3, Animation**) in the main toolbar to create an animation.

During the transient simulation the model is run for 40 s corresponding to two thirds of the full revolution of the impeller.

Notes About the COMSOL Implementation

The present application represents a transient simulation where the impeller velocity is increased from 0 to 1 RPM during the first 20 seconds. In cases where the startup of the problem is not of interest, the time required to reach a fully developed, yet transient, flow state, could be minimized by solving the model in two steps. First, a Frozen Rotor study could be used to reach a good initial solution without having to solve the transient startup of the problem. In order to converge this step for sure, a parametric sweep might be used to first solve the model with a low Reynolds number and increased dynamic viscosity, and then compute it again with the actual dynamic viscosity of the fluid. The frozen rotor solution would then be used as initial condition for the transient simulation.

Application Library path: CFD_Module/Fluid-Structure_Interaction/
baffled_mixer



Modeling Instructions

From the **File** menu, choose **New**.

NEW

In the **New** window, click  **Model Wizard**.

MODEL WIZARD

- 1 In the **Model Wizard** window, click  **3D**.
- 2 In the **Select Physics** tree, select **Fluid Flow** > **Single-Phase Flow** > **Rotating Machinery**,
Fluid Flow > **Laminar Flow**.
- 3 Click **Add**.
- 4 Click  **Study**.
- 5 In the **Select Study** tree, select **General Studies** > **Time Dependent**.
- 6 Click  **Done**.

GEOMETRY I



Import I (impl)

- 1 In the **Geometry** toolbar, click  **Import**.
- 2 In the **Settings** window for **Import**, locate the **Source** section.
- 3 Click  **Browse**.
- 4 Browse to the model's Application Libraries folder and double-click the file
baffled_mixer.mphbin.
- 5 Click  **Import**.

Use the assembly mode to create separate geometry objects. This, together with an identity pair, is needed for the sliding-mesh technique.

Form Union (fin)

- 1 In the **Model Builder** window, under **Component 1 (comp1)** > **Geometry 1** click
Form Union (fin).

- 2 In the **Settings** window for **Form Union/Assembly**, locate the **Form Union/Assembly** section.
- 3 From the **Action** list, choose **Form an assembly**.
- 4 Click  **Build Selected**.
- 5 Click the  **Transparency** button in the **Graphics** toolbar.
- 6 Click the  **Zoom Extents** button in the **Graphics** toolbar.

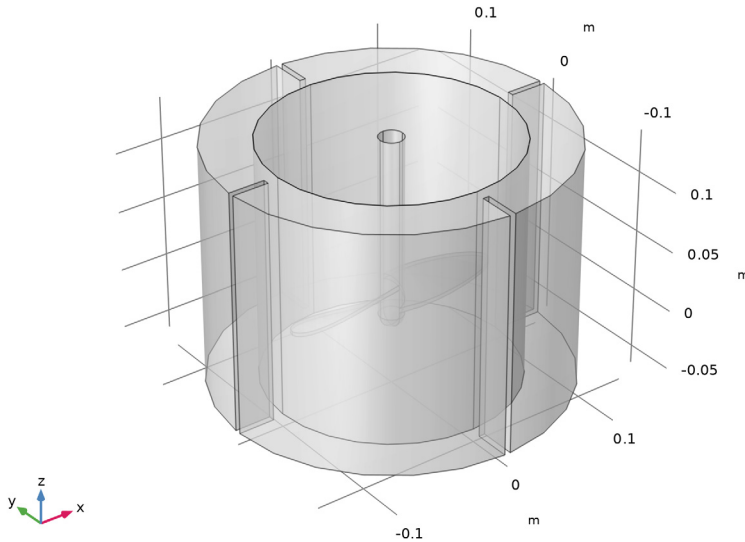

Create a step function that you will use to increase the impeller rotation from zero to 1 RPM in a time of 20 seconds.

DEFINITIONS

In a Time Dependent Study meshes at both sides of the assembly boundary can be compatible only at $t=0$ (if **Identical Mesh** is used at the **Identity Boundary Pair**).

Identity Boundary Pair 1 (ap1)

- 1 In the **Model Builder** window, expand the **Component 1 (comp1) > Definitions** node, then click **Identity Boundary Pair 1 (ap1)**.
- 2 In the **Settings** window for **Pair**, locate the **Advanced** section.
- 3 From the **Elementwise mapping for compatible meshes** list, choose **Off**.

Step 1 (step1)

- 1 In the **Definitions** toolbar, click  **More Functions** and choose **Step**.
- 2 In the **Settings** window for **Step**, locate the **Parameters** section.
- 3 In the **Location** text field, type 10.
- 4 Click to expand the **Smoothing** section. In the **Size of transition zone** text field, type 20.

Variables 1

- 1 In the **Definitions** toolbar, click  **Local Variables**.
- 2 In the **Settings** window for **Variables**, locate the **Variables** section.
- 3 In the table, enter the following settings:



Name	Expression	Unit	Description
rpm	$1[1/\text{min}] * \text{step1}(t[1/\text{s}])$	1/s	Revolutions per minute

MOVING MESH

Rotating Domain 1

- 1 In the **Model Builder** window, under **Component 1 (comp1) > Moving Mesh** click **Rotating Domain 1**.
- 2 In the **Settings** window for **Rotating Domain**, locate the **Domain Selection** section.
- 3 In the list box, select **1**.
- 4 Click  **Remove from Selection**. Only Domain 2 is selected.
- 5 Select Domain 2 only.
- 6 Locate the **Rotation** section. In the f text field, type rpm.

ADD MATERIAL

- 1 In the **Materials** toolbar, click  **Add Material** to open the **Add Material** window.
- 2 Go to the **Add Material** window.
- 3 In the tree, select **Built-in > Water, liquid**.
- 4 Click the **Add to Component** button in the window toolbar.
- 5 In the **Materials** toolbar, click  **Add Material** to close the **Add Material** window.

LAMINAR FLOW (SPF)

All boundaries that are adjacent to the rotating domain will by default be set to rotating boundaries. The bottom boundary should not rotate, so add an additional no-slip wall boundary condition.

Fixed Wall

- 1 In the **Physics** toolbar, click  **Boundaries** and choose **Wall**.
- 2 In the **Settings** window for **Wall**, type Fixed Wall in the **Label** text field.
- 3 Select Boundary 25 only.
- 4 Click to expand the **Wall Movement** section. From the **Translational velocity** list, choose **Zero (Fixed wall)**.

Symmetry 1

- 1 In the **Physics** toolbar, click  **Boundaries** and choose **Symmetry**.
- 2 Select Boundaries 4 and 26 only (top boundaries).

Finally, add a pressure point constraint at one of the top boundaries.

Pressure Point Constraint 1

- 1 In the **Physics** toolbar, click  **Points** and choose **Pressure Point Constraint**.
- 2 Select Point 4 only.

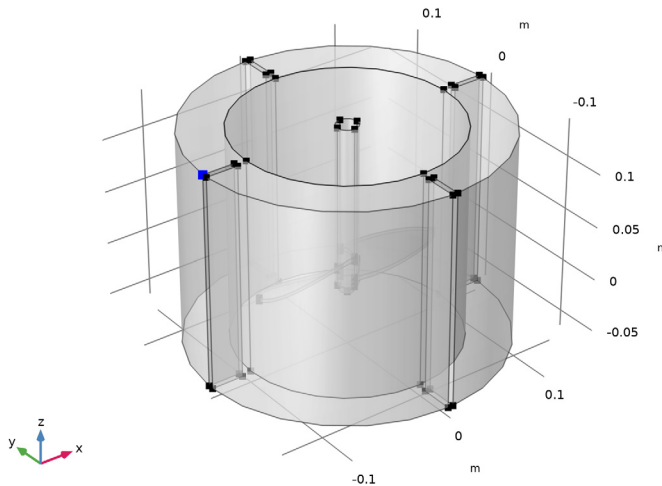

MESH 1

In the **Model Builder** window, under **Component 1 (comp1)** right-click **Mesh 1** and choose **Edit Physics-Induced Sequence**.

Size

- 1 In the **Model Builder** window, under **Component 1 (comp1)** > **Mesh 1** click **Size**.

- 2 In the **Settings** window for **Size**, locate the **Element Size** section.
- 3 Click the **Custom** button.
- 4 Locate the **Element Size Parameters** section. In the **Minimum element size** text field, type 0.0013.

Size 2

- 1 In the **Model Builder** window, click **Size 2**.
- 2 In the **Settings** window for **Size**, locate the **Element Size** section.
- 3 From the **Predefined** list, choose **Finer**.

Boundary Layer Properties 1

- 1 In the **Model Builder** window, expand the **Boundary Layers 1** node, then click **Boundary Layer Properties 1**.
- 2 In the **Settings** window for **Boundary Layer Properties**, in the **Graphics** window toolbar, click  next to **Deselect Box**, then choose **Entity Inside**.
- 3 Select Boundaries 1–3, 5–7, 10–13, 16–22, and 25 only.

Boundary Layers 1

- 1 In the **Model Builder** window, click **Boundary Layers 1**.
- 2 In the **Settings** window for **Boundary Layers**, click to expand the **Corner Settings** section.
- 3 From the **Handling of sharp edges** list, choose **Splitting**.

Boundary Layers 2

- 1 In the **Mesh** toolbar, click  **Boundary Layers**.
- 2 In the **Settings** window for **Boundary Layers**, locate the **Geometric Entity Selection** section.
- 3 From the **Geometric entity level** list, choose **Domain**.
- 4 Select Domain 2 only.

Boundary Layer Properties

- 1 In the **Model Builder** window, click **Boundary Layer Properties**.
- 2 In the **Settings** window for **Boundary Layer Properties**, in the **Graphics** window toolbar, click  next to **Select Box**, then choose **Entity Inside**.
- 3 Select Boundaries 27–36 and 38–47 only.
- 4 Locate the **Layers** section. In the **Number of layers** text field, type 2.
- 5 In the **Thickness adjustment factor** text field, type 5.

Boundary Layers 2

- 1 In the **Model Builder** window, click **Boundary Layers 2**.
- 2 In the **Settings** window for **Boundary Layers**, locate the **Corner Settings** section.
- 3 From the **Handling of sharp edges** list, choose **Trimming**.
- 4 In the **Model Builder** window, right-click **Mesh 1** and choose **Build All**.



STUDY 1

Step 1: Time Dependent

- 1 In the **Model Builder** window, under **Study 1** click **Step 1: Time Dependent**.
- 2 In the **Settings** window for **Time Dependent**, locate the **Study Settings** section.
- 3 In the **Output times** text field, type range (0, 2.5, 60).

Before solving, display the default solver settings to be able to set a maximum time step. The time step is limited with the mesh size and rotational speed at the identity pair in mind.

Solution 1 (sol1)

- 1 In the **Study** toolbar, click  **Show Default Solver**.
- 2 In the **Model Builder** window, expand the **Solution 1 (sol1)** node, then click **Time-Dependent Solver 1**.
- 3 In the **Settings** window for **Time-Dependent Solver**, click to expand the **Time Stepping** section.
- 4 From the **Steps taken by solver** list, choose **Manual**.
- 5 In the **Time step** text field, type 1.
- 6 In the **Study** toolbar, click  **Compute**.

RESULTS





The default plot groups visualize the velocity field in a slice plot and the pressure contours on the walls. Follow these steps to create a plot of the shear rate.

3D Plot Group 3

- 1 In the **Results** toolbar, click  **3D Plot Group**.
- 2 In the **Settings** window for **3D Plot Group**, locate the **Plot Settings** section.
- 3 From the **Frame** list, choose **Spatial (x, y, z)**.

Slice 1

- 1 Right-click **3D Plot Group 3** and choose **Slice**.

- 2 In the **Settings** window for **Slice**, click **Replace Expression** in the upper-right corner of the **Expression** section. From the menu, choose **Component 1 (comp1) > Laminar Flow > Velocity and pressure > spf.sr - Shear rate - 1/s**.
- 3 Locate the **Plane Data** section. From the **Plane** list, choose **xy-planes**.
- 4 From the **Entry method** list, choose **Coordinates**.
- 5 In the **3D Plot Group 3** toolbar, click  **Plot**.
- 6 Click the  **Transparency** button in the **Graphics** toolbar.
- 7 Click the  **Go to Default View** button in the **Graphics** toolbar.
- 8 Click the  **Zoom Extents** button in the **Graphics** toolbar.

Finally, create an arrow plot of the velocity field in a 2D cross section through the mixer's axis.

Cut Plane 1

In the **Results** toolbar, click  **Cut Plane**.

2D Plot Group 4

- 1 In the **Results** toolbar, click  **2D Plot Group**.
- 2 In the **Settings** window for **2D Plot Group**, locate the **Data** section.
- 3 From the **Dataset** list, choose **Cut Plane 1**.
- 4 From the **Time (s)** list, choose **55**.
- 5 Locate the **Plot Settings** section. From the **Frame** list, choose **Spatial (x, y, z)**.

Arrow Surface 1

- 1 Right-click **2D Plot Group 4** and choose **Arrow Surface**.
- 2 In the **Settings** window for **Arrow Surface**, locate the **Expression** section.
- 3 From the **Coordinate system** list, choose **Cut plane**.
- 4 In the **x-component** text field, type v .
- 5 In the **y-component** text field, type w .
- 6 Locate the **Arrow Positioning** section. Find the **x grid points** subsection. In the **Points** text field, type 33.
- 7 Find the **y grid points** subsection. In the **Points** text field, type 33.
- 8 Locate the **Coloring and Style** section.
- 9 Select the **Scale factor** checkbox. In the associated text field, type 5.
- 10 In the **2D Plot Group 4** toolbar, click  **Plot**.

