



Model created in COMSOL Multiphysics 6.4

Flow in an Airlift Loop Reactor

Introduction

This example illustrates multiphase flow modeling in an airlift loop reactor. Air bubbles are injected through two frits at the bottom of a water-filled reactor. Due to buoyancy, the bubbles rise, inducing a circulating motion in the liquid. There is no mass transfer between the phases.

Model Definition

The model parameters are taken from the experimental work presented in [Ref. 1](#), and are summarized in [Table 1](#). The liquid phase in the reactor is water while the gas phase is air.

TABLE 1: MODEL DATA.

PROPERTY	VALUE	DESCRIPTION
H	1.75 m	Reactor height
W	0.5 m	Reactor width
T	0.08 m	Reactor thickness
d_b	$3 \cdot 10^{-3}$ m	Bubble diameter
R	0.02 m	Frit radius
L	0.16 m	Width of riser and downcomer channels
V_{in}	0.015 m/s	Superficial velocity at inlet
C_w	$5 \cdot 10^4$ kg/(m ³ ·s)	Slip-velocity proportionality constant
$\rho_{g,in}$	0.9727 kg/m ³	Gas density at inlet

BOUNDARY CONDITIONS

Inlet Boundary Condition

Two frits with radius 0.02 m are located at the bottom of the reactor (see [Figure 1](#)). Air bubbles with a diameter of 3 mm and superficial speed of 0.015 m/s are injected through the frits. For the liquid, the frits are described by a wall condition.

Outlet Boundary Condition

The top of the geometry (xz -plane, $y = 1.75$ m) is a free surface. The surface motion is neglected and the surface is instead approximated by a slip condition for the liquid. The gas is free to exit the reactor through this boundary.

Symmetry Condition

Mirror symmetry is invoked in the xy -plane at $z = 0.04$ m.

Wall Condition

Other boundaries are represented by wall functions for the liquid, and with zero gas flux for the bubbles.

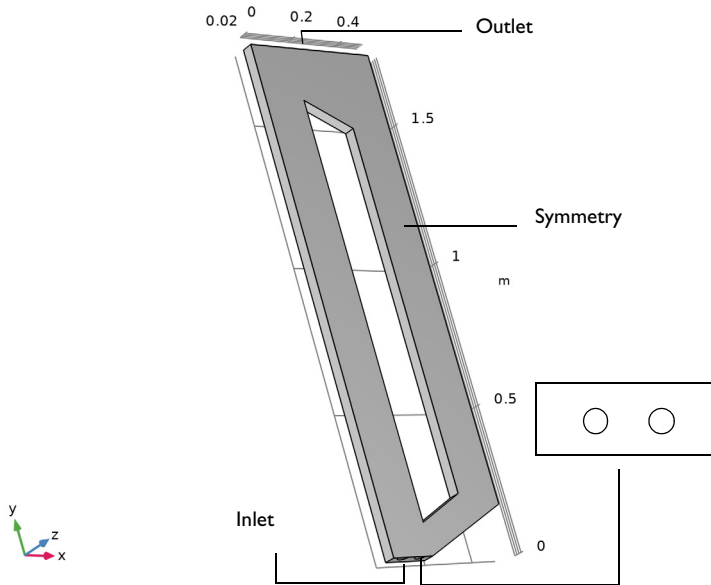

Figure 1: Model geometry for the airlift loop reactor.

BUBBLY FLOW INTERFACE AND TURBULENCE MODELING

The Bubbly Flow interface sets up a multiphase-flow model for gas bubbles in a liquid. The physics interface tracks the averaged gas-phase concentration rather than each bubble in detail. It solves for the liquid velocity, the pressure, and the volume fraction of the gas phase. Details of the governing equations are presented in the theory section for the Bubbly Flow interfaces in the *CFD Module User's Guide*.

For laminar flow the gas velocity \mathbf{u}_g is calculated from

$$\mathbf{u}_g = \mathbf{u}_l + \mathbf{u}_{\text{slip}}$$

where \mathbf{u}_l stands for the liquid-phase velocity, and \mathbf{u}_{slip} stands for the relative velocity between gas and liquid, the so-called slip velocity.

The slip velocity is calculated from a slip model. The Bubbly Flow interface provides several slip models. The most appropriate slip model for this reactor is a pressure-drag balance slip model with a drag coefficient tuned for large bubbles.

The experiments in [Ref. 1](#) suggest that the Reynolds number for the fully developed flow is $2 \cdot 10^4$, and hence that the flow is turbulent. The k - ε turbulence model for bubbly flows is similar to the single-phase k - ε turbulence model (details can be found in the theory sections for the Turbulent Flow and Bubbly Flow interfaces in the *CFD Module User's Guide*). However, for bubbly flow cases, additional source terms are added to the turbulence equations. These account for the extra production and dissipation of turbulence due to the relative motion between the gas bubbles and the liquid. The additional source term in the k equation, denoted S_k , accounts for the bubble-induced turbulence and is given by (see [Ref. 2](#))

$$S_k = -C_k \phi_g \nabla p \cdot \mathbf{u}_{\text{slip}}$$

The additional source term in the ε -equation, denoted S_ε , accounting for the bubble-induced turbulence dissipation, is given by

$$S_\varepsilon = \frac{\varepsilon}{k} C_\varepsilon S_k$$

where C_k and C_ε are model constants. The values of C_k and C_ε are highly problem dependent but can often be tuned to obtain good agreement between experimental data and simulations (see [Ref. 3](#)). According to [Ref. 2](#), admissible values for C_k and C_ε are in the ranges of $[0.01, 1]$ and $[1, 1.92]$, respectively. [Ref. 3](#) does however use C_ε values less than 1 and they obtain good agreements between the measurements and simulations. In this example C_k and C_ε are set to 0.6 and 1.4, respectively.

To account for turbulent transport of the bubbles, a drift velocity is added for the gas-phase velocity field:

$$\mathbf{u}_g = \mathbf{u}_l + \mathbf{u}_{\text{slip}} + \mathbf{u}_{\text{drift}}$$

where

$$\mathbf{u}_{\text{drift}} = -\frac{\mu_T}{\sigma_T \rho_l} \frac{\nabla \phi_g}{\phi_g}$$

and σ_T is the turbulent Schmidt number.

Using the k - ε model, the turbulent dynamic viscosity is defined as

$$\mu_T = \rho_l C_\mu \frac{k^2}{\varepsilon}$$

where C_{μ} is a model constant (for details, see the theory section for the Bubbly Flow interfaces in the *CFD Module User's Guide*).

In the Bubbly Flow interface you can easily switch the k - ϵ turbulence model. You can also control whether to include or exclude the bubble-induced turbulence term S_k by adjusting the value of C_k . A C_k equal to zero means that the bubble induced turbulence is neglected.

The Physical Model settings for the Bubbly Flow interface also provides a low gas concentration option which is active per default. This option is applicable if the gas concentration is less than 2%, in which case the transport equations can be simplified compared to cases with higher gas concentrations. [Ref. 1](#) does not specifically report the gas concentration, but photographs of the reactor indicate that the gas concentration might be high, so the low gas concentration option is not enabled in this model.

MESH GENERATION

The mesh must be very fine in the vicinity of the frits in order to resolve steep gradients in bubble concentration. The mesh also needs to be relatively fine in the interior of the reactor since the presence of bubbles creates relatively complicated flow structures.

SOLVING THE MODEL

The goal is to obtain a stationary solution, but when it comes to buoyant flows, the best way to reach it is often a time-dependent simulation. Buoyant flows can feature intricate flow structures that are in a delicate balance with each other. It can sometimes be difficult to find such flow structures with a stationary solver while a time-dependent simulation lets the structures evolve to their final state.

Results and Discussion

[Figure 2](#) shows the gas volume fraction and velocity streamlines for the liquid in the symmetry plane at $t = 30$ s. The results are qualitatively in good agreement with [Ref. 1](#) except that the experiments show a recirculation zone at the upper-left corner while this recirculation zone is absent in the simulation.

The maximum value of the gas concentration is about 7% close to the two frits and higher than 2% in substantial parts of the reactor. This confirms that the low-gas concentration assumption would not have been valid.

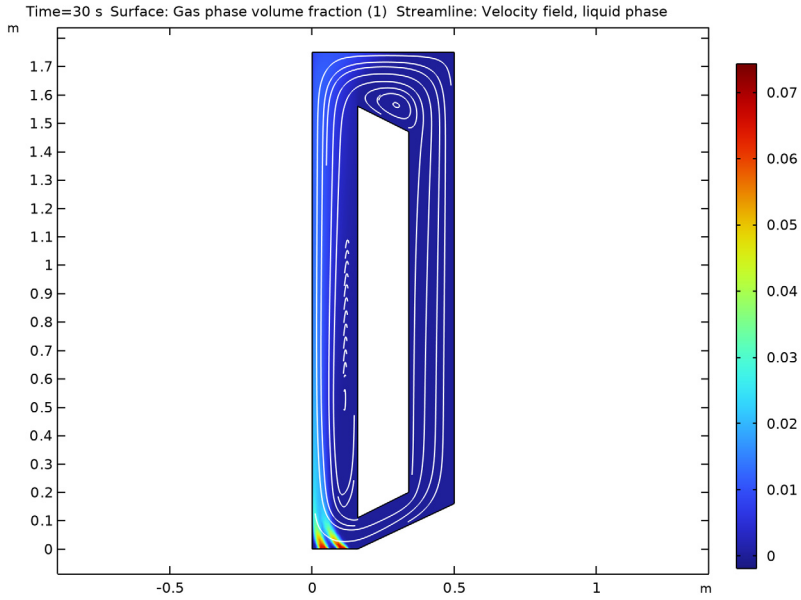

Figure 2: Results of a time-dependent simulation at $t = 30$ s. The surface is the gas concentration, and the streamlines are liquid velocity.

Figure 3 shows the turbulent viscosity. The effect of bubble induced turbulence can be perceived by the relatively high levels of turbulent viscosity just above the frits and also beneath the free surface. The latter can be the reason to why there is no recirculation zone by the upper-left corner. But it could also be that the missing recirculation zone is caused by sloshing which has been neglected in this example.

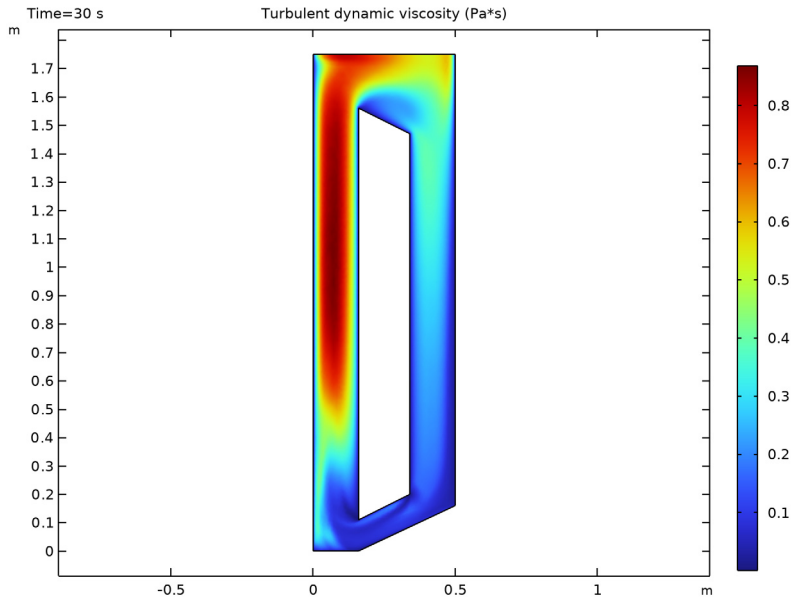

Figure 3: Turbulent viscosity in the symmetry plane.

Experimental data is reported for four probe position, #3, #5, #7 and #9. They correspond to lines in the symmetry plane at different, constant heights, namely $y = 300$ mm, $y = 650$ mm, $y = 1250$ mm and $y = 1650$ mm respectively. The probes are positioned in the rising part of the reactor. Comparisons between simulation and experiments are shown in Figure 4. The agreement is good in the lower part of the reactor (positions #3 and #5) where both liquid and gas velocities from the simulation are in close quantitative agreement with their experimental counterparts. However, the agreement is less good in the upper part of the reactor due to the missing recirculation zone in the upper-left corner. The simulation results are still qualitatively correct at probe position #7, but the velocities are too low close to the inner wall. The lack of the recirculation zone is apparent at probe position #9 where the experiments show negative liquid velocities along the outer wall while the simulation shows positive liquid velocities.

The overall agreement must still be deemed good considering the many modeling assumptions used in this example.

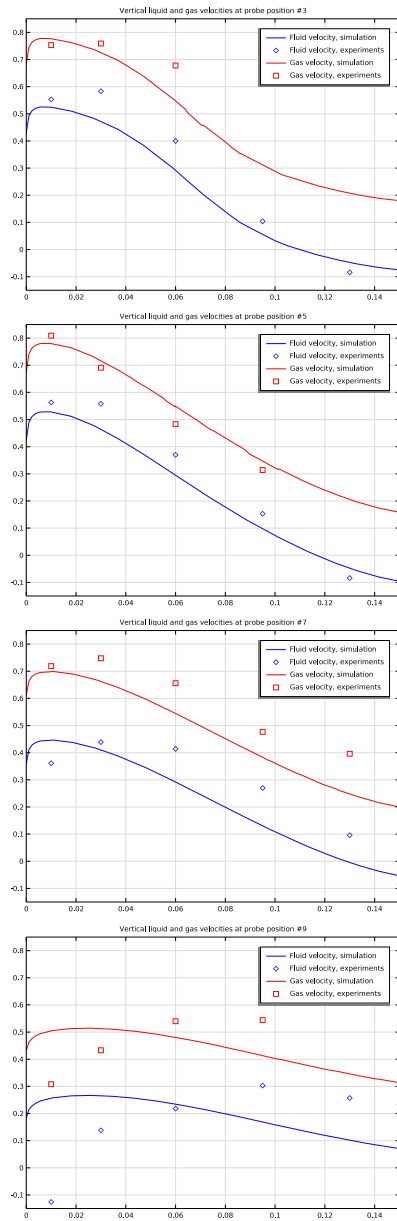

Figure 4: Comparison between simulation results and experimental results for vertical velocities at four different probe positions.

References

1. S. Becker, A. Sokolichin, and G. Eigenberger, “Gas-liquid flow in bubble columns and loop reactors: Part II. Comparison of detailed experiments and flow simulations,” *Chem. Eng. Sci.*, vol. 49, pp. 5747–5762, 1994.
 2. D. Kuzmin and S. Turek, “Numerical simulation of turbulent bubbly flows,” *Third Int. Symposium on Two-Phase Flow Modeling and Experiment*, Pisa, pp. 22–24, Sept. 2004.
 3. A. Sokolichin, G. Eigenberger, and A. Lapin, “Simulation of Buoyancy Driven Bubbly Flow: Established Simplification and Open Questions,” *Fluid Mechanics and Transport Phenomena*, vol. 51, no. 1, pp. 24–45, 2004.
-

Application Library path: CFD_Module/Verification_Examples/
airlift_loop_reactor



Modeling Instructions

From the **File** menu, choose **New**.

NEW

In the **New** window, click  **Model Wizard**.

MODEL WIZARD

- 1 In the **Model Wizard** window, click  **3D**.
- 2 In the **Select Physics** tree, select **Fluid Flow** > **Multiphase Flow** > **Bubbly Flow** > **Bubbly Flow, Turbulent Flow** > **Bubbly Flow, k- ϵ (bf)**.
- 3 Click **Add**.
- 4 Click  **Study**.
- 5 In the **Select Study** tree, select **General Studies** > **Time Dependent**.
- 6 Click  **Done**.

GLOBAL DEFINITIONS

First, define some model parameters.

Parameters 1



- 1 In the **Model Builder** window, under **Global Definitions** click **Parameters 1**.

- 2 In the **Settings** window for **Parameters**, locate the **Parameters** section.
- 3 In the table, enter the following settings:

Name	Expression	Value	Description
H	1.75[m]	1.75 m	Reactor height
W	0.5[m]	0.5 m	Reactor width
T	0.08[m]	0.08 m	Reactor thickness
d_b	3e-3[m]	0.003 m	Bubble diameter
R	0.02[m]	0.02 m	Frit radius
L	0.16[m]	0.16 m	Width of riser and downcomer channels
V_in	0.015[m/s]	0.015 m/s	Inlet velocity
Cw	5e4[kg/(m ³ *s)]	50000 kg/(m ³ *s)	Slip-velocity proportionality constant
rhog_in	0.9727[kg/(m ³)]	0.9727 kg/m ³	Gas density at inlet

Define a step function to be used when ramping up the inlet gas flux as a function of time.

Step 1 (step1)

- 1 In the **Home** toolbar, click  **Functions** and choose **Global > Step**.
- 2 In the **Settings** window for **Step**, locate the **Parameters** section.
- 3 In the **Location** text field, type 5.
- 4 Click to expand the **Smoothing** section. In the **Size of transition zone** text field, type 10.
- 5 Click  **Plot**.



GEOMETRY I

Create the geometry. To simplify this step, insert a prepared geometry sequence.

- 1 In the **Geometry** toolbar, click **Insert Sequence** and choose **Insert Sequence**.
- 2 Browse to the model's Application Libraries folder and double-click the file `airlift_loop_reactor_geom_sequence.mph`.
Full geometry instructions can be found at the end of the document.
- 3 In the **Geometry** toolbar, click  **Build All**.
- 4 In the **Model Builder** window, under **Component 1 (comp1)** click **Geometry I**.
- 5 Hold down the left mouse button and drag in the **Graphics** window to rotate the geometry. Similarly, use the right mouse button to translate the geometry and the middle button to zoom.

Now pick up the materials from the Material Library.

ADD MATERIAL

- 1 In the **Materials** toolbar, click  **Add Material** to open the **Add Material** window.
- 2 Go to the **Add Material** window.
- 3 In the tree, select **Built-in > Air**.
- 4 Click the **Add to Component** button in the window toolbar.
- 5 In the tree, select **Built-in > Water, liquid**.
- 6 Click the **Add to Component** button in the window toolbar.
- 7 In the **Materials** toolbar, click  **Add Material** to close the **Add Material** window.

BUBBLY FLOW, K- ϵ (BF)

Fluid Properties 1

- 1 In the **Settings** window for **Fluid Properties**, locate the **Materials** section.
- 2 From the **Liquid** list, choose **Water, liquid (mat2)**.
- 3 From the **Gas** list, choose **Air (mat1)**.
- 4 Locate the **Gas Properties** section. From the ρ_g list, choose **Calculate from ideal gas law**.
- 5 In the d_b text field, type d_b .
- 6 Locate the **Slip Model** section. From the **Slip model** list, choose **Pressure-drag balance**.
- 7 From the **Drag coefficient model** list, choose **Large bubbles**.
- 8 In the **Model Builder** window, click **Bubbly Flow, k- ϵ (bf)**.
- 9 In the **Settings** window for **Bubbly Flow, k- ϵ** , locate the **Physical Model** section.
- 10 Clear the **Low gas concentration** checkbox.
- 11 Locate the **Turbulence** section. Find the **Turbulence model parameters** subsection. Select the **Edit turbulence model parameters** checkbox.
- 12 In the C_ϵ text field, type 1.4.
- 13 In the C_k text field, type 0.6.

Gravity 1

- 1 In the **Physics** toolbar, click  **Domains** and choose **Gravity**.
- 2 Select Domain 1 only.

Wall 2

- In the **Physics** toolbar, click  **Boundaries** and choose **Wall**.

Gravity 1

- 1 In the **Model Builder** window, click **Gravity 1**.
- 2 In the **Settings** window for **Gravity**, locate the **Gravity** section.
- 3 Specify the **g** vector as

0	x
-g_const	y
0	z

Wall 2

- 1 Click the  **Zoom Extents** button in the **Graphics** toolbar.
- 2 In the **Model Builder** window, click **Wall 2**.
- 3 Select Boundaries 6 and 7 only.
- 4 In the **Settings** window for **Wall**, locate the **Gas Boundary Condition** section.
- 5 From the **Gas boundary condition** list, choose **Gas flux**.
- 6 In the $N_{\rho g \phi g}$ text field, type $V_{in} * \rho_{g_in} * \text{step1}(t[1/s])$.

Wall 3

- 1 In the **Physics** toolbar, click  **Boundaries** and choose **Wall**.
- 2 Select Boundary 5 only.
- 3 In the **Settings** window for **Wall**, locate the **Liquid Boundary Condition** section.
- 4 From the **Liquid boundary condition** list, choose **Slip**.
- 5 Locate the **Gas Boundary Condition** section. From the **Gas boundary condition** list, choose **Gas outlet**.

Initial Values 1

When using gravity it is important to set the initial values of the pressure to hydrostatic conditions.

- 1 In the **Model Builder** window, click **Initial Values 1**.
- 2 In the **Settings** window for **Initial Values**, type $g_const * b.f. \rho_{o1} * (1.75 - y)$ in the p text field.

Pressure Point Constraint 1

- 1 In the **Physics** toolbar, click  **Points** and choose **Pressure Point Constraint**.
- 2 Select Point 23 only.



Symmetry 1

- 1 In the **Physics** toolbar, click  **Boundaries** and choose **Symmetry**.
- 2 Select Boundary 4 only.

MESH 1

- 1 In the **Model Builder** window, under **Component 1 (comp1)** click **Mesh 1**.
- 2 In the **Settings** window for **Mesh**, locate the **Physics-Controlled Mesh** section.
- 3 From the **Element size** list, choose **Coarse**.
- 4 Right-click **Component 1 (comp1) > Mesh 1** and choose **Edit Physics-Induced Sequence**.

Boundary Layer Properties 1

- 1 In the **Model Builder** window, expand the **Component 1 (comp1) > Mesh 1 > Boundary Layers 1** node, then click **Boundary Layer Properties 1**.
- 2 In the **Settings** window for **Boundary Layer Properties**, locate the **Layers** section.
- 3 In the **Number of layers** text field, type 4.
- 4 In the **Thickness adjustment factor** text field, type 3.
- 5 Click  **Build All**.
- 6 Click the  **Zoom Extents** button in the **Graphics** toolbar.

STUDY 1

Step 1: Time Dependent

- 1 In the **Model Builder** window, under **Study 1** click **Step 1: Time Dependent**.
- 2 In the **Settings** window for **Time Dependent**, locate the **Study Settings** section.
- 3 In the **Output times** text field, type range (0, 0.05, 1) * 30.
- 4 From the **Tolerance** list, choose **User controlled**.
- 5 In the **Relative tolerance** text field, type 0.005.
Measurement data makes it possible to estimate manual scales for velocity and pressure.

Solution 1 (sol1)

- 1 In the **Study** toolbar, click  **Show Default Solver**.
- 2 In the **Model Builder** window, expand the **Solution 1 (sol1)** node.
- 3 In the **Model Builder** window, expand the **Study 1 > Solver Configurations > Solution 1 (sol1) > Dependent Variables 1** node, then click **Pressure (comp1.p)**.
- 4 In the **Settings** window for **Field**, locate the **Scaling** section.
- 5 From the **Method** list, choose **Manual**.

- 6 In the **Scale** text field, type 1.7e4.
- 7 In the **Model Builder** window, under **Study 1 > Solver Configurations > Solution 1 (sol1) > Dependent Variables 1** click **Velocity Field, Liquid Phase (comp1.u)**.
- 8 In the **Settings** window for **Field**, locate the **Scaling** section.
- 9 From the **Method** list, choose **Manual**.
- 10 In the **Scale** text field, type 0.5.
- 11 In the **Model Builder** window, collapse the **Solution 1 (sol1)** node.
- 12 In the **Model Builder** window, right-click **Solution 1 (sol1)** and choose **Run**.

RESULTS

The following steps reproduce [Figure 2](#).

Surface 1

- 1 In the **Results** toolbar, click  **More Datasets** and choose **Surface**.
- 2 Select Boundary 4 only.
- 3 In the **Settings** window for **Surface**, locate the **Parameterization** section.
- 4 From the **x- and y-axes** list, choose **xy-plane**.

2D Plot Group 5

In the **Results** toolbar, click  **2D Plot Group**.

Surface 1

Right-click **2D Plot Group 5** and choose **Surface**.

Streamline 1

- 1 In the **Model Builder** window, right-click **2D Plot Group 5** and choose **Streamline**.
- 2 In the **Settings** window for **Streamline**, locate the **Coloring and Style** section.
- 3 Find the **Point style** subsection. From the **Color** list, choose **White**.
- 4 Locate the **Streamline Positioning** section. From the **Positioning** list, choose **Uniform density**.
- 5 In the **Density level** text field, type 7.2.
- 6 In the **2D Plot Group 5** toolbar, click  **Plot**.

The following steps reproduce [Figure 3](#).

2D Plot Group 6

In the **Results** toolbar, click  **2D Plot Group**.

Surface 1

- 1 Right-click **2D Plot Group 6** and choose **Surface**.
- 2 In the **Settings** window for **Surface**, locate the **Expression** section.
- 3 In the **Expression** text field, type `bf.muT`.
- 4 In the **2D Plot Group 6** toolbar, click  **Plot**.

Proceed to reproduce the 1D-plots in [Figure 4](#). Start by importing experimental data.



v13

- 1 In the **Results** toolbar, click  **Table**.
- 2 In the **Settings** window for **Table**, type `v13` in the **Label** text field.
- 3 Locate the **Data** section. Click  **Import**.
- 4 Browse to the model's Application Libraries folder and double-click the file `airlift_loop_reactor_v1_no3.txt`.

vg3

- 1 In the **Results** toolbar, click  **Table**.
- 2 In the **Settings** window for **Table**, type `vg3` in the **Label** text field.
- 3 Locate the **Data** section. Click  **Import**.
- 4 Browse to the model's Application Libraries folder and double-click the file `airlift_loop_reactor_vg_no3.txt`.

v15

- 1 In the **Results** toolbar, click  **Table**.
- 2 In the **Settings** window for **Table**, type `v15` in the **Label** text field.
- 3 Locate the **Data** section. Click  **Import**.
- 4 Browse to the model's Application Libraries folder and double-click the file `airlift_loop_reactor_v1_no5.txt`.

vg5

- 1 In the **Results** toolbar, click  **Table**.
- 2 In the **Settings** window for **Table**, type `vg5` in the **Label** text field.
- 3 Locate the **Data** section. Click  **Import**.
- 4 Browse to the model's Application Libraries folder and double-click the file `airlift_loop_reactor_vg_no5.txt`.

v17



- 1 In the **Results** toolbar, click  **Table**.

- 2 In the **Settings** window for **Table**, type v17 in the **Label** text field.
- 3 Locate the **Data** section. Click  **Import**.
- 4 Browse to the model's Application Libraries folder and double-click the file airlift_loop_reactor_v1_no7.txt.

vg7

- 1 In the **Results** toolbar, click  **Table**.
- 2 In the **Settings** window for **Table**, type vg7 in the **Label** text field.
- 3 Locate the **Data** section. Click  **Import**.
- 4 Browse to the model's Application Libraries folder and double-click the file airlift_loop_reactor_vg_no7.txt.

v19

- 1 In the **Results** toolbar, click  **Table**.
- 2 In the **Settings** window for **Table**, type v19 in the **Label** text field.
- 3 Locate the **Data** section. Click  **Import**.
- 4 Browse to the model's Application Libraries folder and double-click the file airlift_loop_reactor_v1_no9.txt.

vg9

- 1 In the **Results** toolbar, click  **Table**.
- 2 In the **Settings** window for **Table**, type vg9 in the **Label** text field.
- 3 Locate the **Data** section. Click  **Import**.
- 4 Browse to the model's Application Libraries folder and double-click the file airlift_loop_reactor_vg_no9.txt.

Define cut lines that correspond to the experimental probe positions.

No3

- 1 In the **Results** toolbar, click  **Cut Line 3D**.
- 2 In the **Settings** window for **Cut Line 3D**, type No3 in the **Label** text field.
- 3 Locate the **Line Data** section. In row **Point 1**, set **y** to 0.3 and **z** to 0.04.
- 4 In row **Point 2**, set **x** to 0.15, **y** to 0.3, and **z** to 0.04.
- 5 From the **Snapping** list, choose **Snap to closest boundary**.

No5

- 1 Right-click **No3** and choose **Duplicate**.

- 2 In the **Settings** window for **Cut Line 3D**, type No5 in the **Label** text field.
- 3 Locate the **Line Data** section. In row **Point 1**, set **y** to 0.65.
- 4 In row **Point 2**, set **y** to 0.65.

No7

- 1 Right-click **No5** and choose **Duplicate**.
- 2 In the **Settings** window for **Cut Line 3D**, type No7 in the **Label** text field.
- 3 Locate the **Line Data** section. In row **Point 1**, set **y** to 1.25.
- 4 In row **Point 2**, set **y** to 1.25.

No9

- 1 Right-click **No7** and choose **Duplicate**.
- 2 In the **Settings** window for **Cut Line 3D**, type No9 in the **Label** text field.
- 3 Locate the **Line Data** section. In row **Point 1**, set **y** to 1.65.
- 4 In row **Point 2**, set **y** to 1.65.

Probe position #3

- 1 In the **Results** toolbar, click  **ID Plot Group**.
- 2 In the **Settings** window for **ID Plot Group**, type Probe position #3 in the **Label** text field.
- 3 Locate the **Data** section. From the **Dataset** list, choose **No3**.
- 4 From the **Time selection** list, choose **Last**.
- 5 Click to expand the **Title** section. From the **Title type** list, choose **Manual**.
- 6 In the **Title** text area, type Vertical liquid and gas velocities at probe position #3.

Line Graph 1

- 1 Right-click **Probe position #3** and choose **Line Graph**.
- 2 In the **Settings** window for **Line Graph**, locate the **y-Axis Data** section.
- 3 In the **Expression** text field, type v .
- 4 Click to expand the **Coloring and Style** section. From the **Color** list, choose **Blue**.
- 5 Click to expand the **Legends** section. Select the **Show legends** checkbox.
- 6 From the **Legends** list, choose **Manual**.

7 In the table, enter the following settings:

Legends

Fluid velocity, simulation

Table Graph 1

- 1 In the **Model Builder** window, right-click **Probe position #3** and choose **Table Graph**.
- 2 In the **Settings** window for **Table Graph**, locate the **Coloring and Style** section.
- 3 Find the **Line style** subsection. From the **Line** list, choose **None**.
- 4 From the **Color** list, choose **Blue**.
- 5 Find the **Line markers** subsection. From the **Marker** list, choose **Diamond**.
- 6 Click to expand the **Legends** section. Select the **Show legends** checkbox.
- 7 From the **Legends** list, choose **Manual**.
- 8 In the table, enter the following settings:

Legends

Fluid velocity, experiments

Line Graph 2

- 1 Right-click **Probe position #3** and choose **Line Graph**.
- 2 In the **Settings** window for **Line Graph**, locate the **y-Axis Data** section.
- 3 In the **Expression** text field, type `bf.ugy`.
- 4 Locate the **Coloring and Style** section. From the **Color** list, choose **Red**.
- 5 Locate the **Legends** section. Select the **Show legends** checkbox.
- 6 From the **Legends** list, choose **Manual**.
- 7 In the table, enter the following settings:

Legends

Gas velocity, simulation

Table Graph 2

- 1 Right-click **Probe position #3** and choose **Table Graph**.
- 2 In the **Settings** window for **Table Graph**, locate the **Data** section.
- 3 From the **Table** list, choose **vg3**.
- 4 Locate the **Coloring and Style** section. Find the **Line style** subsection. From the **Line** list, choose **None**.

- 5 From the **Color** list, choose **Red**.
- 6 Find the **Line markers** subsection. From the **Marker** list, choose **Square**.
- 7 Locate the **Legends** section. Select the **Show legends** checkbox.
- 8 From the **Legends** list, choose **Manual**.
- 9 In the table, enter the following settings:

Legends

Gas velocity, experiments

Probe position #3

- 1 In the **Model Builder** window, click **Probe position #3**.
- 2 In the **Settings** window for **ID Plot Group**, locate the **Axis** section.
- 3 Select the **Manual axis limits** checkbox.
- 4 In the **x minimum** text field, type 0.
- 5 In the **x maximum** text field, type 0.15.
- 6 In the **y minimum** text field, type -0.15.
- 7 In the **y maximum** text field, type 0.85.
- 8 In the **Probe position #3** toolbar, click  **Plot**.

Probe position #3.1

Right-click **Probe position #3** and choose **Duplicate**.

Probe position #3

In the **Model Builder** window, collapse the **Results > Probe position #3** node.

Probe position #5

- 1 In the **Model Builder** window, under **Results** click **Probe position #3.1**.
- 2 In the **Settings** window for **ID Plot Group**, type Probe position #5 in the **Label** text field.
- 3 Locate the **Data** section. From the **Dataset** list, choose **No5**.
- 4 Locate the **Title** section. In the **Title** text area, type Vertical liquid and gas velocities at probe position #5.

Table Graph 1

- 1 In the **Model Builder** window, expand the **Probe position #5** node, then click **Table Graph 1**.
- 2 In the **Settings** window for **Table Graph**, locate the **Data** section.

3 From the **Table** list, choose **vl5**.

Table Graph 2

- 1** In the **Model Builder** window, click **Table Graph 2**.
- 2** In the **Settings** window for **Table Graph**, locate the **Data** section.
- 3** From the **Table** list, choose **vg5**.
- 4** In the **Probe position #5** toolbar, click  **Plot**.

Probe position #5

- 1** In the **Model Builder** window, click **Probe position #5**.
- 2** Click  **Plot**.

Probe position #5.1

Right-click **Probe position #5** and choose **Duplicate**.

Probe position #5

In the **Model Builder** window, collapse the **Results > Probe position #5** node.

Probe position #7

- 1** In the **Model Builder** window, under **Results** click **Probe position #5.1**.
- 2** In the **Settings** window for **ID Plot Group**, type Probe position #7 in the **Label** text field.
- 3** Locate the **Data** section. From the **Dataset** list, choose **No7**.
- 4** Locate the **Title** section. In the **Title** text area, type Vertical liquid and gas velocities at probe position #7.

Table Graph 1

- 1** In the **Model Builder** window, expand the **Probe position #7** node, then click **Table Graph 1**.
- 2** In the **Settings** window for **Table Graph**, locate the **Data** section.
- 3** From the **Table** list, choose **vl7**.

Table Graph 2

- 1** In the **Model Builder** window, click **Table Graph 2**.
- 2** In the **Settings** window for **Table Graph**, locate the **Data** section.
- 3** From the **Table** list, choose **vg7**.

Probe position #7

- 1** In the **Model Builder** window, click **Probe position #7**.

2 In the **Probe position #7** toolbar, click  **Plot**.

Probe position #7.1

Right-click **Probe position #7** and choose **Duplicate**.

Probe position #7

In the **Model Builder** window, collapse the **Results > Probe position #7** node.

Probe position #9

1 In the **Model Builder** window, under **Results** click **Probe position #7.1**.

2 In the **Settings** window for **ID Plot Group**, type **Probe position #9** in the **Label** text field.

3 Locate the **Data** section. From the **Dataset** list, choose **No9**.

4 Locate the **Title** section. In the **Title** text area, type **Vertical liquid and gas velocities at probe position #9**.

Table Graph 1

1 In the **Model Builder** window, expand the **Probe position #9** node, then click **Table Graph 1**.

2 In the **Settings** window for **Table Graph**, locate the **Data** section.

3 From the **Table** list, choose **vI9**.

Table Graph 2

1 In the **Model Builder** window, click **Table Graph 2**.

2 In the **Settings** window for **Table Graph**, locate the **Data** section.

3 From the **Table** list, choose **vg9**.

Probe position #9

1 In the **Model Builder** window, click **Probe position #9**.

2 In the **Probe position #9** toolbar, click  **Plot**.

3 In the **Model Builder** window, collapse the **Probe position #9** node.



Appendix. Geometry Modeling Instructions

From the **File** menu, choose **New**.

NEW

In the **New** window, click  **Model Wizard**.

MODEL WIZARD

- 1 In the **Model Wizard** window, click  **3D**.
- 2 Click  **Done**.

GLOBAL DEFINITIONS

First, define some model parameters.

Parameters 1

- 1 In the **Model Builder** window, under **Global Definitions** click **Parameters 1**.
- 2 In the **Settings** window for **Parameters**, locate the **Parameters** section.
- 3 In the table, enter the following settings:

Name	Expression	Value	Description
H	1.75[m]	1.75 m	Reactor height
W	0.5[m]	0.5 m	Reactor width
T	0.08[m]	0.08 m	Reactor thickness
d_b	3e-3[m]	0.003 m	Bubble diameter
R	0.02[m]	0.02 m	Frit radius
L	0.16[m]	0.16 m	Width of riser and downcomer channels
V_in	0.015[m/s]	0.015 m/s	Inlet velocity
Cw	5e4[kg/(m ³ *s)]	50000 kg/(m ³ *s)	Slip-velocity proportionality constant
rhog_in	0.9727[kg/(m ³)]	0.9727 kg/m ³	Gas density at inlet

GEOMETRY 1

Work Plane 1 (wp1)

- 1 In the **Geometry** toolbar, click  **Work Plane**.
- 2 In the **Settings** window for **Work Plane**, click  **Go to Plane Geometry**.

Work Plane 1 (wp1) > Plane Geometry

In the **Model Builder** window, click **Plane Geometry**.

Work Plane 1 (wp1) > Polygon 1 (pol1)

- 1 In the **Work Plane** toolbar, click  **Polygon**.
- 2 In the **Settings** window for **Polygon**, locate the **Coordinates** section.

3 In the table, enter the following settings:

xw (m)	yw (m)
0	0
L	0
W	L
W	H
0	H

4 In the **Work Plane** toolbar, click  **Build All**.

Work Plane 1 (wp1) > Polygon 2 (pol2)

1 In the **Work Plane** toolbar, click  **Polygon**.

2 In the **Settings** window for **Polygon**, locate the **Coordinates** section.

3 In the table, enter the following settings:

xw (m)	yw (m)
L	0.11
0.34	0.2
0.34	1.47
L	1.56

4 In the **Work Plane** toolbar, click  **Build All**.

Work Plane 1 (wp1) > Difference 1 (dif1)

1 In the **Work Plane** toolbar, click  **Booleans and Partitions** and choose **Difference**.

2 Select the object **pol1** only.

3 In the **Settings** window for **Difference**, locate the **Difference** section.

4 Click to select the  **Activate Selection** toggle button for **Objects to subtract**.

5 Select the object **pol2** only.

6 In the **Work Plane** toolbar, click  **Build All**.

Extrude 1 (ext1)

1 In the **Model Builder** window, under **Component 1 (comp1) > Geometry 1** right-click **Work Plane 1 (wp1)** and choose **Extrude**.

2 In the **Settings** window for **Extrude**, locate the **Distances** section.

3 In the table, enter the following settings:

Distances (m)

T

4 Click  **Build All Objects**.

Work Plane 2 (wp2)

1 In the **Geometry** toolbar, click  **Work Plane**.

2 In the **Settings** window for **Work Plane**, locate the **Plane Definition** section.

3 From the **Plane** list, choose **zx-plane**.

4 Click  **Go to Plane Geometry**.

Work Plane 2 (wp2) > Circle 1 (c1)

1 In the **Work Plane** toolbar, click  **Circle**.

2 In the **Settings** window for **Circle**, locate the **Size and Shape** section.

3 In the **Radius** text field, type R.

4 Locate the **Position** section. In the **xw** text field, type T/2.

5 In the **yw** text field, type 0.11.

Work Plane 2 (wp2) > Circle 2 (c2)

1 In the **Work Plane** toolbar, click  **Circle**.

2 In the **Settings** window for **Circle**, locate the **Size and Shape** section.

3 In the **Radius** text field, type R.

4 Locate the **Position** section. In the **xw** text field, type T/2.

5 In the **yw** text field, type T/2.

6 In the **Work Plane** toolbar, click  **Build All**.

Union 1 (uni1)

1 In the **Model Builder** window, right-click **Geometry 1** and choose **Booleans and Partitions** > **Union**.

2 Click in the **Graphics** window and then press Ctrl+A to select both objects.



3 In the **Settings** window for **Union**, click  **Build All Objects**.

Block 1 (blk1)





1 In the **Geometry** toolbar, click  **Block**.

2 In the **Settings** window for **Block**, locate the **Size and Shape** section.

3 In the **Depth** text field, type 2.

- 4 Locate the **Position** section. In the **z** text field, type T/2.
- 5 Click  **Build All Objects**.
- 6 Click the  **Zoom Extents** button in the **Graphics** toolbar.

Difference 1 (dif1)

- 1 In the **Geometry** toolbar, click  **Booleans and Partitions** and choose **Difference**.
- 2 Select the object **uni1** only, to add it to the **Objects to add** list.
- 3 In the **Settings** window for **Difference**, locate the **Difference** section.
- 4 Click to select the  **Activate Selection** toggle button for **Objects to subtract**.
- 5 Select the object **blk1** only.
- 6 In the **Geometry** toolbar, click  **Build All**.
- 7 Click the  **Zoom Extents** button in the **Graphics** toolbar.