



Model created in COMSOL Multiphysics 6.4

Airflow over an Ahmed Body



Introduction

This example describes how to calculate the turbulent flow field around a simple car-like geometry using the CFD Module's Turbulent Flow, k - ϵ interface. Detailed instructions guide you through the different steps of the modeling process in COMSOL Multiphysics.

Model Definition

The Ahmed body represents a simplified, ground vehicle geometry of a bluff body type. Its shape is simple enough to allow for accurate flow simulation but retains some important practical features relevant to automobile bodies. The geometry was first defined by Ahmed, who also measured its aerodynamic properties in wind-tunnel experiments (Ref. 1). Further experiments have also been performed by Lienhart and Becker (Ref. 2). The Ahmed body has become a popular benchmark case for RANS models (Ref. 3).

GEOMETRY

The Ahmed body is presented in Figure 1. The total length (L) of the body is 1.044 m from front to end. It is 0.288 m in height and 0.389 m in width. Cylindrical legs of 0.05 m in length are attached to the bottom surface. The angle of the rear slanting surface is typically varied between 0 and 40 degrees. This particular geometry has a slant angle of 25 degrees, which is the same slant angle used in Ref. 3.

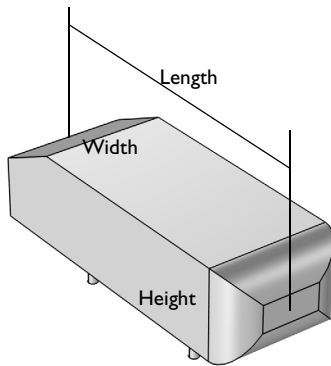

Figure 1: Ahmed body with 25 degree slant of the rear face.

The body is placed in a flow domain that is $8L$ -by- $2L$ -by- $2L$ (length-by-width-by-height), with its front positioned $2L$ from the flow inlet face. Mirror symmetry reduces the computational domain by half, as shown in [Figure 2](#).

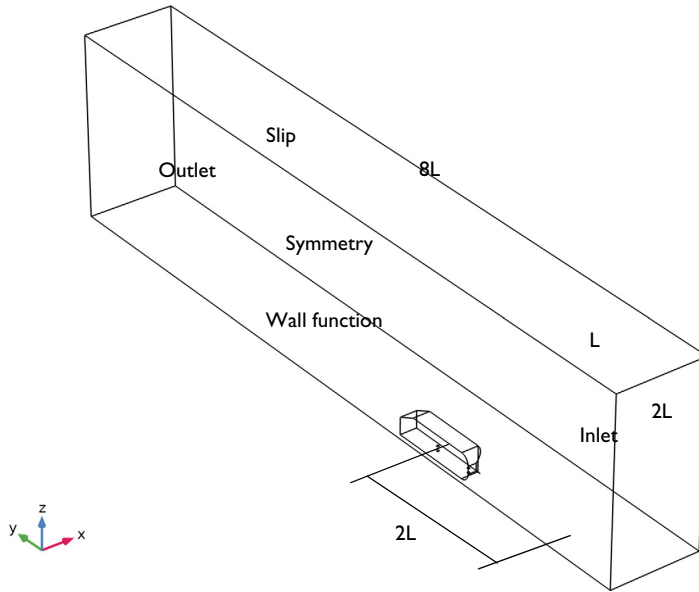

Figure 2: The size of the computational domain is reduced by mirror symmetry.

TURBULENCE MODEL

The Reynolds number based on the length of the body, L , and the inlet velocity is $2.77 \cdot 10^6$, which means that the flow is turbulent. The k - ϵ turbulence model is applied to account for the turbulence. The k - ϵ turbulence model is described in the theory section for the Turbulent Flow interfaces in the *CFD Module User's Guide*.

BOUNDARY CONDITIONS

Air enters the computational domain at a freestream velocity $u_\infty = 40$ m/s normal to the inlet surface. Experimental inlet conditions from [Ref. 3](#) are used for the velocity and turbulent kinetic energy. To obtain a condition for ϵ , [Ref. 3](#) suggests to set $\mu_T = 10\mu$ at the inlet. At the outlet, a Pressure condition is applied.

The floor of the flow domain and surface of the Ahmed body are described by wall functions. Wall functions could also be applied to the outer wall and the ceiling of the wind tunnel. Their main effect on the flow around the body is, however, to keep the flow

contained; therefore it suffices to model these as slip walls. The temperature is assumed to be 293 K and the reference pressure is 1 atm.

MESHING

A common mesh size in Ref. 3 is half a million cells for simulations with wall functions. However, those simulations do not include the stilts (the legs that support the body), and the computational domains are smaller. Hence, you can expect to need an even larger mesh in this simulation to resolve the flow. How large is, however, difficult to know in advance.

There are two important aspects of the meshing. The first is to resolve the flow in the wake. To achieve this, additional mesh control entities are introduced in the geometry. These entities are advantageous to normal geometrical entities since they are removed once they have been meshed. A smoothing algorithm then smooths the mesh locally in order to minimize gradients in the mesh size. Also, it is easier to introduce a boundary layer mesh when the control entities are removed.

Results and Discussion

A key figure for the Ahmed body is the total drag coefficient, C_D , which is defined as

$$\frac{F}{A_p} = C_D \frac{\rho u_\infty^2}{2} \quad (1)$$

where F is the total drag force on the body, A_p is the area of the body projected on a plane perpendicular to the flow direction (that is, the xz -plane), ρ is the density (approximately equal to 1.2 kg/m^3), and u_∞ is the freestream velocity (equal to 40 m/s). A_p can be calculated by taking the integral of the y -component of the surface normal vector of the object. Doing so, shows that A_p is equal to 0.059 m^2 for the Ahmed body including the stilts. The contributions to C_D are commonly reported as the pressure coefficients on the front, slant, and base and the skin friction drag coefficient. These numbers are given in Table 1.

TABLE 1: DRAG COEFFICIENTS.

	CK FRONT	CS SLANT	CB BASE	SKIN FRICTION	CD TOTAL DRAG
Measurements	0.020	0.140	0.070	0.055	0.285
$k-\epsilon$	0.065	0.125	0.087	0.047	0.324

As can be seen, most contributions are in reasonable agreements with experiments. The total drag is predicted with reasonable accuracy 14%, but the individual contributions deviate from experimental values significantly.

The pressure coefficient on the front is too high and the skin friction too low. Ref. 4 uses two different versions of the k - ϵ model and two different wall function formulations and all combinations show this behavior. It can probably be attributed to the fact that wall functions are not very good at predicting the transition observed in the experiments to take place on the front and roof of the body.

The low value of the slant pressure drag coefficient can be understood by looking at Figure 3, which shows streamlines in the symmetry plane. Experimental results indicate that the flow along the slant is attached almost everywhere and that there are two small recirculation regions behind the base. The computational results capture this behavior, but the extent of the recirculation zones is somewhat overpredicted. The pressure drag coefficient, especially for the slant, is very sensitive to the exact shape and location of the recirculation regions.

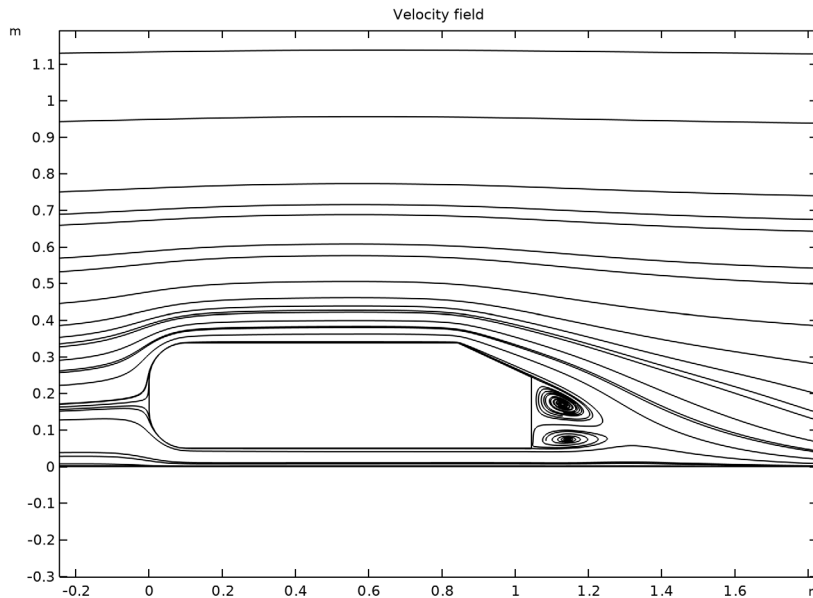

Figure 3: Streamlines in the symmetry plane.

Figure 4 shows a 3D plot of the streamlines behind the Ahmed body. The thickness of the lines is given by the turbulent kinetic energy. The most notable feature of the flow field is an “empty” region behind the body. The streamlines on the edge of the region are thick but with low velocity magnitude. This region is constituted of the recirculation vortices visible in Figure 3. The region ends when vortices from the trailing edges of the body

merge into two counterrotating vortices (only one vortex is visible because the other vortex is on the other side of the symmetry plane).

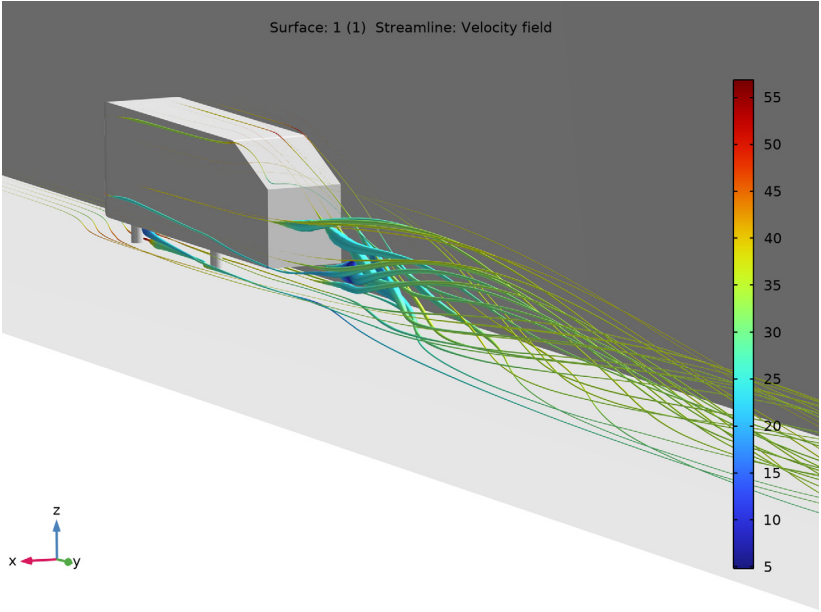

Figure 4: Streamlines behind the Ahmed body. The streamlines are colored by the velocity magnitude and their thickness is proportional to the turbulent kinetic energy.

More details are visible in [Figure 5](#) and [Figure 6](#), which show streamlines plots of the velocity in the xz -plane 80 mm and 200 mm downstream of the body, respectively.

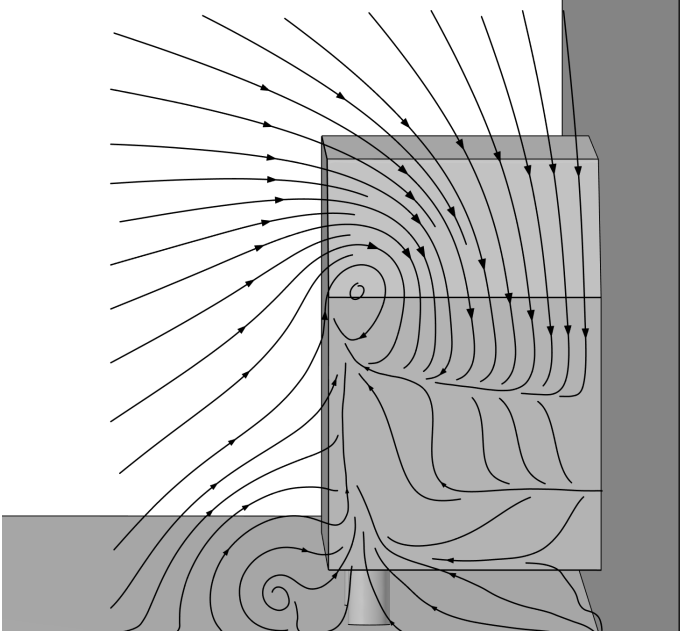

Figure 5: Velocity in the xz -plane at $y = L + 0.08$ m.

The flow pattern 80 mm downstream of the body shows two major vortices, one emanating from the outer edge of the slant and one emanating from the interaction between the floor and the stilts. The flow is qualitatively equal to the experimental results

(Ref. 2). There are however quantitative differences. The upper vortex is smaller compared to experiments while the lower vortex is more pronounced than in the experiments.

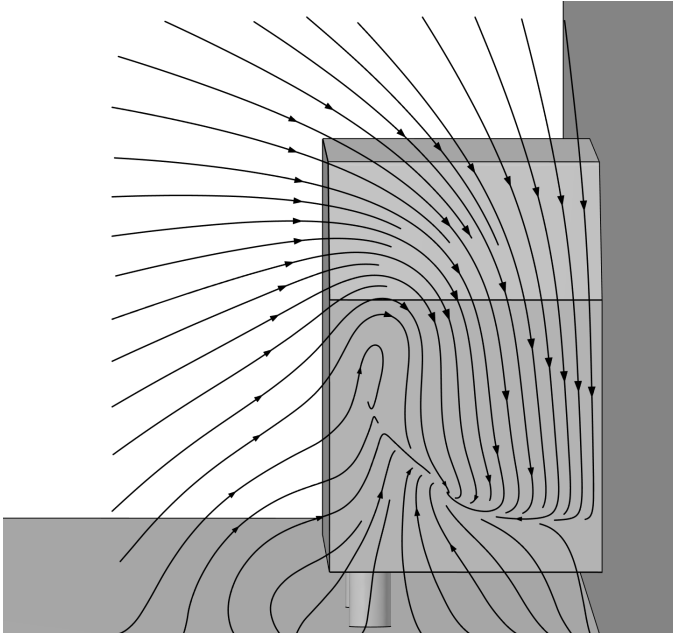

Figure 6: Velocity in the xz -plane at $y = L + 0.20$ m.

The flow pattern 200 mm downstream of the body shows that one major vortex is beginning to form but remains of the separate vortices can still be detected. The formation is, however, not proceeded as far as in the experiments.

In conclusion, the major features of the flow are well-captured by the k - ϵ model, but there are details that deviate from experimental data. This finding is in agreement with other RANS simulations of the Ahmed body (Ref. 3).

References

1. S.R. Ahmed, G. Ramm, and G. Faltn, "Some Salient Features of the Time-Averaged Ground Vehicle Wake," *SAE Technical Paper 840300*, 1984.
2. H. Lienhart and S. Becker, "Flow and Turbulence Structure in the Wake of a Simplified Car Model," *SAE 2003 World Congress*, SAE Paper 2003-01-0656, Detroit, Michigan, 2003.

3. *9th ERCOFTAC/IAHR Workshop on Refined Turbulence Modelling*, Darmstadt University of Technology, Germany, 2001.

4. T.J. Craft, S.E. Gant, H. Iacovides, B.E. Launder, and C.M.E. Robinson, "Computational Study of Flow Around the 'Ahmed' Car Body," *9th ERCOFTAC/IAHR Workshop on Refined Turbulence Modelling*, 2001.

Application Library path: CFD_Module/Verification_Examples/ahmed_body



Modeling Instructions

From the **File** menu, choose **New**.

NEW

In the **New** window, click  **Model Wizard**.

MODEL WIZARD

- 1 In the **Model Wizard** window, click  **3D**.
- 2 In the **Select Physics** tree, select **Fluid Flow > Single-Phase Flow > Turbulent Flow > Turbulent Flow, k-ε (spf)**.
- 3 Click **Add**.
- 4 Click  **Study**.
- 5 In the **Select Study** tree, select **General Studies > Stationary**.
- 6 Click  **Done**.

GLOBAL DEFINITIONS

Parameters I

- 1 In the **Model Builder** window, under **Global Definitions** click **Parameters I**.
- 2 In the **Settings** window for **Parameters**, locate the **Parameters** section.
- 3 In the table, enter the following settings:

Name	Expression	Value	Description
L	1.044 [m]	1.044 m	Body length
D	0.389 [m]	0.389 m	Body width
H_body	0.288 [m]	0.288 m	Body height





Name	Expression	Value	Description
S1	0.222[m]	0.222 m	Slant length
Sb	$H_body - S1 * \sin(25[\text{deg}])$	0.19418 m	Slant base
R1	$\text{sqrt}(S1^2 - (H_body - Sb)^2)$	0.2012 m	Roof length
Uin	40[m/s]	40 m/s	Inlet velocity
rho0	1.2[kg/m^3]	1.2 kg/m ³	Reference density

GEOMETRY I

Import 1 (imp1)

- 1 In the **Geometry** toolbar, click  **Import**.
- 2 In the **Settings** window for **Import**, locate the **Source** section.
- 3 Click  **Browse**.
- 4 Browse to the model's Application Libraries folder and double-click the file `ahmed_body.mphbin`.
- 5 Click  **Import**.

Block 1 (blk1)



- 1 In the **Geometry** toolbar, click  **Block**.
- 2 In the **Settings** window for **Block**, locate the **Size and Shape** section.
- 3 In the **Width** text field, type $2*L$.
- 4 In the **Depth** text field, type $8*L$.
- 5 In the **Height** text field, type $2*L$.
- 6 Locate the **Position** section. In the **x** text field, type $-L$.
- 7 In the **y** text field, type $-2*L$.
- 8 Click  **Build Selected**.
- 9 Click the  **Go to Default View** button in the **Graphics** toolbar.
- 10 Click the  **Wireframe Rendering** button in the **Graphics** toolbar to view the entire geometry.

Block 2 (blk2)

- 1 In the **Geometry** toolbar, click  **Block**.
- 2 In the **Settings** window for **Block**, locate the **Size and Shape** section.
- 3 In the **Width** text field, type L .

- 4 In the **Depth** text field, type $8*L$.
- 5 In the **Height** text field, type $2*L$.
- 6 Locate the **Position** section. In the **x** text field, type $-L$.
- 7 In the **y** text field, type $-2*L$.

Difference 1 (dif1)

- 1 In the **Geometry** toolbar, click  **Booleans and Partitions** and choose **Difference**.
- 2 Select the object **blk1** only.
- 3 In the **Settings** window for **Difference**, locate the **Difference** section.
- 4 Click to select the  **Activate Selection** toggle button for **Objects to subtract**.
- 5 Select the objects **blk2** and **imp1** only.

All subsequent steps create geometric objects that are only relevant for meshing.

Cylinder 1 (cyl1)

- 1 In the **Geometry** toolbar, click  **Cylinder**.
- 2 In the **Settings** window for **Cylinder**, locate the **Object Type** section.
- 3 From the **Type** list, choose **Surface**.
- 4 Locate the **Size and Shape** section. In the **Radius** text field, type $2.2*L$.
- 5 In the **Height** text field, type L .
- 6 Locate the **Position** section. In the **y** text field, type $0.2*L$.
- 7 In the **z** text field, type $-0.1*L$.
- 8 Locate the **Axis** section. From the **Axis type** list, choose **x-axis**.

Delete Entities 1 (del1)

- 1 In the **Model Builder** window, right-click **Geometry 1** and choose **Delete Entities**.

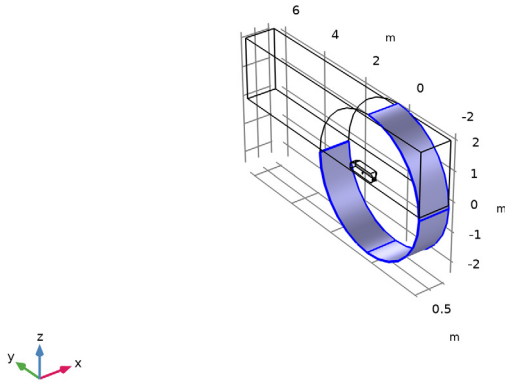

2 On the object **cyll**, select Boundaries 1, 3, and 4 only.

It might be easier to select the boundaries by using the **Selection List** window. To open this window, in the **Home** toolbar click **Windows** and choose **Selection List**. (If you are running the cross-platform desktop, you find **Windows** in the main menu.)



These are all surfaces of the cylinder, except the curved surface behind the body.

Union 1 (uni1)

- 1 In the **Geometry** toolbar, click  **Booleans and Partitions** and choose **Union**.
- 2 Click in the **Graphics** window and then press Ctrl+A to select both objects.
- 3 In the **Settings** window for **Union**, click  **Build Selected**.

Delete Entities 2 (del2)

- 1 Right-click **Geometry 1** and choose **Delete Entities**.
- 2 On the object **uni1**, select Boundaries 10 and 16 only.

These are the boundaries that protrude above and beneath the channel.

Next, create a domain behind the body. This region will require finer mesh size, because significant turbulence effects are expected.

Work Plane 1 (wp1)



- 1 In the **Geometry** toolbar, click  **Work Plane**.
- 2 In the **Settings** window for **Work Plane**, locate the **Plane Definition** section.

- 3 From the **Plane type** list, choose **Face parallel**.
- 4 On the object **del2**, select Boundary 22 only.
- 5 Click to expand the **Local Coordinate System** section. From the **Origin** list, choose **Vertex projection**.
- 6 On the object **del2**, select Point 27 only.
- 7 In the **Rotation** text field, type 180.

Work Plane 1 (wp1) > Plane Geometry

In the **Model Builder** window, click **Plane Geometry**.

Work Plane 1 (wp1) > Polygon 1 (pol1)

- 1 In the **Work Plane** toolbar, click  **Polygon**.
- 2 In the **Settings** window for **Polygon**, locate the **Coordinates** section.
- 3 From the **Data source** list, choose **Vectors**.
- 4 In the **xw** text field, type 0 Sb Sb H_body H_body H_body H_body 0.
- 5 In the **yw** text field, type 0 0 0 -R1 -R1 L L L.
- 6 In the **Work Plane** toolbar, click  **Build All**.

Extrude 1 (ext1)

- 1 In the **Model Builder** window, under **Component 1 (comp1) > Geometry 1** right-click **Work Plane 1 (wp1)** and choose **Extrude**.
- 2 In the **Settings** window for **Extrude**, locate the **Distances** section.
- 3 In the table, enter the following settings:

Distances (m)
D/2

- 4 Click  **Build All Objects**.

Ignore Edges 1 (ige1)

- 1 In the **Geometry** toolbar, click  **Virtual Operations** and choose **Ignore Edges**.

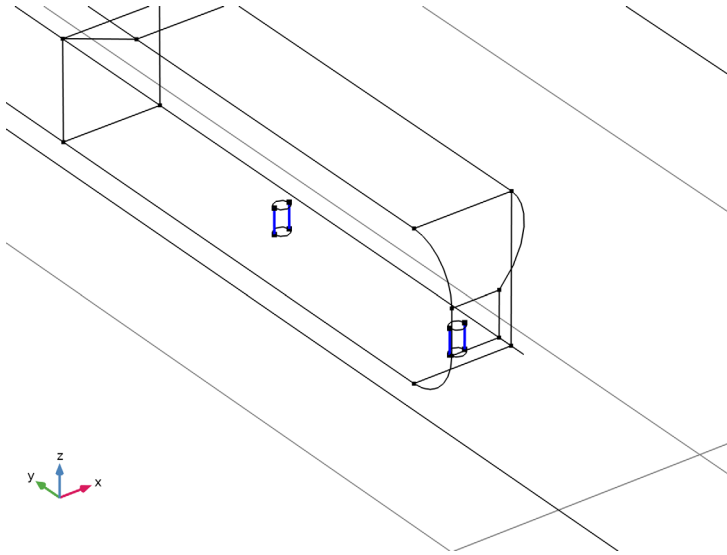

- 2 On the object **fin**, select Edges 36, 41, 46, and 47 only, which belong to the cylindrical legs.



Mesh Control Domains 1 (mcd1)

- 1 In the **Geometry** toolbar, click  **Virtual Operations** and choose **Mesh Control Domains**.
- 2 On the object **ige1**, select Domain 2 only.

Mesh Control Faces 1 (mcf1)

- 1 In the **Geometry** toolbar, click  **Virtual Operations** and choose **Mesh Control Faces**.
- 2 Click the  **Zoom Extents** button in the **Graphics** toolbar.
- 3 On the object **mcd1**, select Boundary 12 only.
- 4 In the **Geometry** toolbar, click  **Build All**.



The model geometry is now complete. Compare with [Figure 2](#).

GLOBAL DEFINITIONS

Create an interpolation function from data available in a file. This function provides data for the turbulent kinetic energy at the inlet.



Interpolation 1 (int1)

- 1 In the **Home** toolbar, click  **Functions** and choose **Global > Interpolation**.
- 2 In the **Settings** window for **Interpolation**, locate the **Definition** section.
- 3 From the **Data source** list, choose **File**.



- 4 Click  **Browse**.
 - 5 Browse to the model's Application Libraries folder and double-click the file `ahmed_body_kin.txt`.
 - 6 Click  **Import**.
 - 7 Locate the **Data Column Settings** section. In the table, click to select the cell at row number 1 and column number 1.
 - 8 In the **Unit** text field, type `m`.
 - 9 In the table, click to select the cell at row number 2 and column number 1.
 - 10 In the **Unit** text field, type `m`.
 - 11 In the table, click to select the cell at row number 3 and column number 1.
 - 12 In the **Name** text field, type `kin`.
 - 13 In the **Unit** text field, type `m^2/s^2`.
- Create an explicit selection of the boundaries of the body.

DEFINITIONS

Body

- 1 In the **Definitions** toolbar, click  **Explicit**.
- 2 In the **Settings** window for **Explicit**, type `Body` in the **Label** text field.
- 3 Locate the **Input Entities** section. From the **Geometric entity level** list, choose **Boundary**.
- 4 Click the  **Select Box** button in the **Graphics** toolbar.
Use the Select box tool to mark all boundaries that belong to the body, which corresponds to:
- 5 Select Boundaries 5–11 and 13–16 only.

ADD MATERIAL

- 1 In the **Materials** toolbar, click  **Add Material** to open the **Add Material** window.
- 2 Go to the **Add Material** window.
- 3 In the tree, select **Built-in > Air**.
- 4 Click the **Add to Component** button in the window toolbar.
- 5 In the **Materials** toolbar, click  **Add Material** to close the **Add Material** window.

TURBULENT FLOW, K- ϵ (SPF)

Wall 2

- 1 In the **Physics** toolbar, click  **Boundaries** and choose **Wall**.
- 2 In the **Settings** window for **Wall**, locate the **Boundary Condition** section.
- 3 From the **Wall condition** list, choose **Slip**.
- 4 Select Boundaries 4 and 17 only.

Symmetry 1

- 1 In the **Physics** toolbar, click  **Boundaries** and choose **Symmetry**.
- 2 Select Boundary 1 only.

Inlet 1

- 1 In the **Physics** toolbar, click  **Boundaries** and choose **Inlet**.
- 2 Select Boundary 2 only.
- 3 In the **Settings** window for **Inlet**, locate the **Turbulence Conditions** section.
- 4 Click the **Specify turbulence variables** button.
- 5 In the k_0 text field, type $\text{kin}(x, z)$.
- 6 In the ϵ_0 text field, type $\text{spf.C_mu} * \text{kin}(x, z)^2 * \text{spf.rho} / (10 * 1.814e-5 [\text{Pa*s}])$.
- 7 Locate the **Velocity** section. Click the **Velocity field** button.
- 8 Specify the \mathbf{u}_0 vector as

0	x
Uin	y
0	z

Outlet 1

- 1 In the **Physics** toolbar, click  **Boundaries** and choose **Outlet**.
- 2 Select Boundary 12 only.

Define variables and integration operators to calculate the drag and pressure coefficients.

DEFINITIONS

Integration 1 (intop1)



In the **Definitions** toolbar, click  **Nonlocal Couplings** and choose **Integration**.

Add a nonlocal integration coupling for all surfaces on the Ahmed body.

- 1 In the **Settings** window for **Integration**, type Id in the **Operator name** text field.
- 2 Locate the **Source Selection** section. From the **Geometric entity level** list, choose **Boundary**.
- 3 Click  **Paste Selection**.
- 4 In the **Paste Selection** dialog, type 5-11 , 13-16 in the **Selection** text field.
- 5 Click **OK**.



Add a nonlocal integration coupling for the slant.

Integration 2 (intop2)

- 1 In the **Definitions** toolbar, click  **Nonlocal Couplings** and choose **Integration**.
- 2 In the **Settings** window for **Integration**, type Is in the **Operator name** text field.
- 3 Locate the **Source Selection** section. From the **Geometric entity level** list, choose **Boundary**.
- 4 Click  **Paste Selection**.
- 5 In the **Paste Selection** dialog, type 10 in the **Selection** text field.
- 6 Click **OK**.



Add a nonlocal integration coupling for the front.

Integration 3 (intop3)

- 1 In the **Definitions** toolbar, click  **Nonlocal Couplings** and choose **Integration**.
- 2 In the **Settings** window for **Integration**, type Ik in the **Operator name** text field.
- 3 Locate the **Source Selection** section. From the **Geometric entity level** list, choose **Boundary**.
- 4 Click  **Paste Selection**.
- 5 In the **Paste Selection** dialog, type 5 6 7 13 in the **Selection** text field.
- 6 Click **OK**.

Add a nonlocal integration coupling for the base.

Integration 4 (intop4)

- 1 In the **Definitions** toolbar, click  **Nonlocal Couplings** and choose **Integration**.
- 2 In the **Settings** window for **Integration**, type Ib in the **Operator name** text field.
- 3 Locate the **Source Selection** section. From the **Geometric entity level** list, choose **Boundary**.
- 4 Click  **Paste Selection**.

5 In the **Paste Selection** dialog, type 11 in the **Selection** text field.

6 Click **OK**.

Variables 1

1 In the **Model Builder** window, right-click **Definitions** and choose **Variables**.

2 In the **Settings** window for **Variables**, locate the **Variables** section.

3 In the table, enter the following settings:

Name	Expression	Unit	Description
A	$\text{Id}(\max(\text{spf.nymesh}, 0))$	m ²	Projected area
Cd	$2 / (A * U_{in}^2 * \rho_0) * \text{Id}(p * \text{spf.nymesh})$		Total drag coefficient
Cs	$2 / (A * U_{in}^2 * \rho_0) * \text{Is}(p * \text{spf.nymesh})$		Slant pressure coefficient
Ck	$2 / (A * U_{in}^2 * \rho_0) * \text{Ik}(p * \text{spf.nymesh})$		Front pressure coefficient
Cb	$2 / (A * U_{in}^2 * \rho_0) * \text{Ib}(p * \text{spf.nymesh})$		Base pressure coefficient
Sf	$\text{Id}(\text{spf.rho} * \text{spf.u_tau} * ((v - \text{spf.nymesh} * (u * \text{spf.nymesh} + v * \text{spf.nymesh} + w * \text{spf.nymesh}))) / \text{spf.uPlus})$	N	Skin friction
Csf	$2 / (A * U_{in}^2 * \rho_0) * \text{Sf}$		Skin friction coefficient

In the expression for the skin friction, the wall function equation is used directly for maximum accuracy.

MESH 1

In the **Model Builder** window, under **Component 1 (comp1)** right-click **Mesh 1** and choose **Edit Physics-Induced Sequence**.

Size

1 In the **Model Builder** window, under **Component 1 (comp1) > Mesh 1** click **Size**.

2 In the **Settings** window for **Size**, locate the **Element Size Parameters** section.

3 In the **Maximum element size** text field, type 0.1.

4 In the **Minimum element size** text field, type 0.0025.

5 In the **Curvature factor** text field, type 0.4.

6 In the **Resolution of narrow regions** text field, type 0.25.

Size 1

- 1 In the **Model Builder** window, click **Size 1**.
- 2 In the **Settings** window for **Size**, locate the **Geometric Entity Selection** section.
- 3 Click  **Clear Selection**.
- 4 Select Boundaries 24 and 26 only.
- 5 Locate the **Element Size Parameters** section.
- 6 Select the **Maximum element size** checkbox. In the associated text field, type 0.05.

Size 2

- 1 In the **Model Builder** window, click **Size 2**.
- 2 Select Boundary 3 only.
- 3 In the **Settings** window for **Size**, locate the **Element Size Parameters** section.
- 4 In the **Maximum element size** text field, type 0.035.
- 5 Click  **Build Selected**.

Size 3

- 1 In the **Model Builder** window, right-click **Mesh 1** and choose **Size**.
- 2 In the **Settings** window for **Size**, locate the **Geometric Entity Selection** section.
- 3 From the **Geometric entity level** list, choose **Boundary**.
- 4 Select Boundaries 10 and 11 only.
- 5 Locate the **Element Size** section. Click the **Custom** button.
- 6 Locate the **Element Size Parameters** section.
- 7 Select the **Maximum element size** checkbox. In the associated text field, type 0.01.

Size 4

- 1 Right-click **Mesh 1** and choose **Size**.
- 2 In the **Settings** window for **Size**, locate the **Geometric Entity Selection** section.
- 3 From the **Geometric entity level** list, choose **Boundary**.

4 Select Boundaries 5–9, 13, and 16 only.

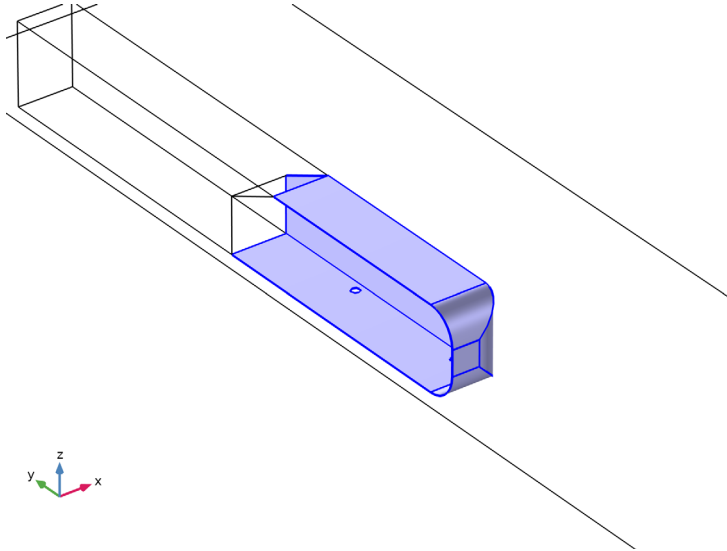

5 Locate the **Element Size** section. Click the **Custom** button.

6 Locate the **Element Size Parameters** section.

7 Select the **Maximum element size** checkbox. In the associated text field, type 0.02.

Size 5

1 Right-click **Mesh 1** and choose **Size**.

2 In the **Settings** window for **Size**, locate the **Geometric Entity Selection** section.

3 From the **Geometric entity level** list, choose **Edge**.

4 Select Edges 35 and 36 only.

5 Locate the **Element Size** section. Click the **Custom** button.

6 Locate the **Element Size Parameters** section.

7 Select the **Maximum element size** checkbox. In the associated text field, type 0.01.

Corner Refinement 1

In the **Model Builder** window, right-click **Corner Refinement 1** and choose **Disable**.

Free Tetrahedral 1

1 In the **Model Builder** window, click **Free Tetrahedral 1**.

2 In the **Settings** window for **Free Tetrahedral**, locate the **Domain Selection** section.

3 From the **Geometric entity level** list, choose **Domain**.

4 Select Domain 3 only.



Size 1

- 1 Right-click **Free Tetrahedral 1** and choose **Size**.
- 2 In the **Settings** window for **Size**, locate the **Element Size** section.
- 3 Click the **Custom** button.
- 4 Locate the **Element Size Parameters** section.
- 5 Select the **Maximum element growth rate** checkbox. In the associated text field, type 1.03.

Free Tetrahedral 1

Right-click **Free Tetrahedral 1** and choose **Build Selected**.

Free Tetrahedral 2

- 1 In the **Mesh** toolbar, click  **Free Tetrahedral**.
- 2 In the **Settings** window for **Free Tetrahedral**, locate the **Domain Selection** section.
- 3 From the **Geometric entity level** list, choose **Domain**.
- 4 Select Domain 1 only.
- 5 Click  **Build Selected**.

Boundary Layers 1

- 1 In the **Model Builder** window, click **Boundary Layers 1**.
- 2 In the **Settings** window for **Boundary Layers**, locate the **Geometric Entity Selection** section.
- 3 Click  **Clear Selection**.
- 4 Select Domain 1 only.
- 5 Click to expand the **Corner Settings** section. In the **Trim for angles greater than** text field, type 280.
.Increase trimming angle to ensure boundary layers at all edges.

Boundary Layer Properties 1

- 1 In the **Model Builder** window, expand the **Boundary Layers 1** node, then click **Boundary Layer Properties 1**.
- 2 In the **Settings** window for **Boundary Layer Properties**, locate the **Layers** section.
- 3 In the **Number of layers** text field, type 6.
- 4 In the **Thickness adjustment factor** text field, type 1.5.

Boundary Layer Properties 2

- 1 In the **Mesh** toolbar, click  **More Attributes** and choose **Boundary Layer Properties**.
- 2 Select Boundaries 5–7 and 13 only.
- 3 In the **Settings** window for **Boundary Layer Properties**, locate the **Layers** section.
- 4 In the **Number of layers** text field, type 6.
- 5 In the **Stretching factor** text field, type 1.25.
- 6 From the **Thickness specification** list, choose **First layer**.
- 7 In the **Thickness** text field, type 5E-4.

Boundary Layers 1

In the **Model Builder** window, right-click **Boundary Layers 1** and choose **Build Selected**.

Swept 1

- 1 In the **Mesh** toolbar, click  **Swept**.
- 2 In the **Settings** window for **Swept**, locate the **Domain Selection** section.
- 3 From the **Geometric entity level** list, choose **Domain**.
- 4 Select Domain 2 only.

Distribution 1

- 1 Right-click **Swept 1** and choose **Distribution**.
- 2 In the **Settings** window for **Distribution**, locate the **Distribution** section.
- 3 From the **Distribution type** list, choose **Predefined**.
- 4 In the **Number of elements** text field, type 28.
- 5 In the **Element ratio** text field, type 6.

- 6 In the **Model Builder** window, right-click **Mesh 1** and choose **Build All**.

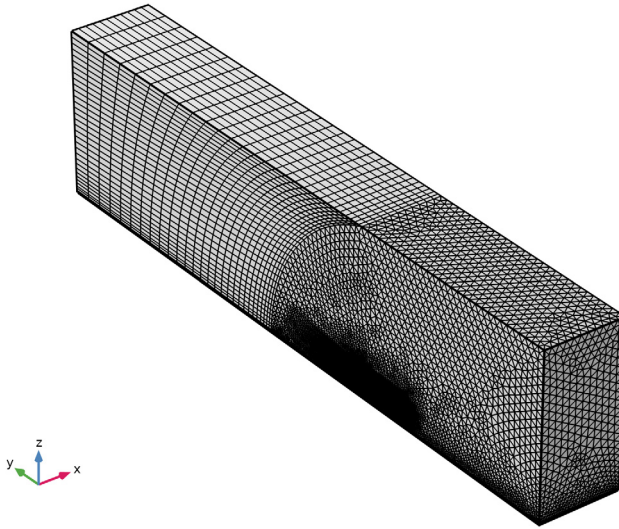

STUDY 1

- 1 In the **Study** toolbar, click  **Compute**.

It is advisable to disable automatic update of plots when working with large 3D models.

RESULTS

- 1 In the **Model Builder** window, click **Results**.
- 2 In the **Settings** window for **Results**, locate the **Update of Results** section.
- 3 Select the **Only plot when requested** checkbox.

Wall Resolution (spf)

Investigate the lift-off in viscous units to verify that the **Wall Resolution** is sufficient.

- 1 In the **Model Builder** window, under **Results** click **Wall Resolution (spf)**.
- 2 In the **Settings** window for **3D Plot Group**, locate the **Plot Settings** section.
- 3 From the **View** list, choose **New view**.

- 4 In the **Wall Resolution (spf)** toolbar, click  **Plot**.

Use the mouse to zoom and rotate to obtain the image below.

The values of the wall lift-off appear to be well within the log-layer on most of the body, and can hence be considered to be acceptable.

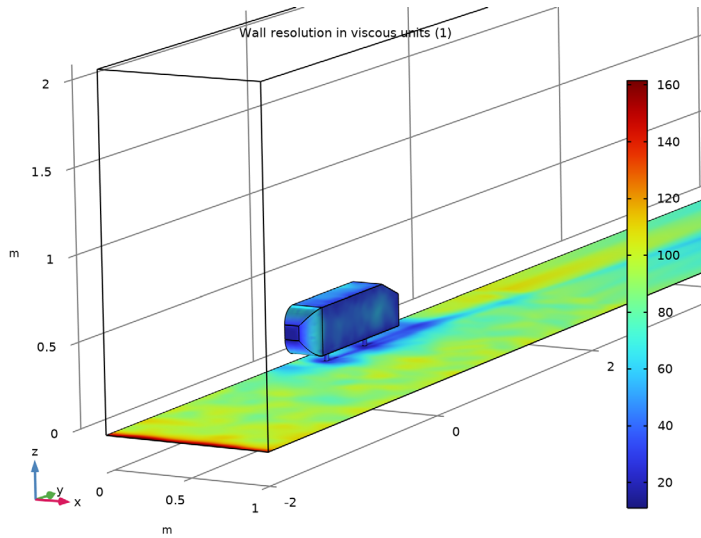

Create a new dataset of the boundaries of the body, bottom, and the symmetry plane. It will be used by different plots for better visualization of the result.

Plot surfaces

- 1 In the **Results** toolbar, click  **More Datasets** and choose **Surface**.
- 2 In the **Settings** window for **Surface**, locate the **Selection** section.
- 3 From the **Selection** list, choose **Body** and add the bottom and back boundary (boundaries 1 and 3).
- 4 Select Boundaries 1, 3, 5–11, and 13–16 only.
- 5 In the **Label** text field, type Plot surfaces.

Multislice 1

- 1 In the **Model Builder** window, expand the **Results > Velocity (spf)** node, then click **Multislice 1**.
- 2 In the **Settings** window for **Multislice**, locate the **Multiplane Data** section.
- 3 Find the **x-planes** subsection. From the **Entry method** list, choose **Coordinates**.
- 4 In the **Coordinates** text field, type 0.15.

- 5 Find the **y-planes** subsection. In the **Planes** text field, type 0.
- 6 Find the **z-planes** subsection. In the **Planes** text field, type 0.
- 7 Locate the **Coloring and Style** section. From the **Color table** list, choose **Disco**.
- 8 From the **Color table transformation** list, choose **Reverse**.

Velocity (spf)

- 1 In the **Model Builder** window, click **Velocity (spf)**.
- 2 In the **Settings** window for **3D Plot Group**, locate the **Plot Settings** section.
- 3 Clear the **Plot dataset edges** checkbox.

Surface 1

- 1 Right-click **Velocity (spf)** and choose **Surface**.
- 2 In the **Settings** window for **Surface**, locate the **Data** section.
- 3 From the **Dataset** list, choose **Plot surfaces**.
- 4 Locate the **Expression** section. In the **Expression** text field, type 1.
- 5 Locate the **Coloring and Style** section. From the **Coloring** list, choose **Uniform**.
- 6 From the **Color** list, choose **Gray**.
- 7 Click the  **Go to YZ View** button in the **Graphics** toolbar and use the mouse to zoom in.

Velocity (spf)

- 1 In the **Model Builder** window, click **Velocity (spf)**.
- 2 In the **Settings** window for **3D Plot Group**, locate the **Plot Settings** section.
- 3 From the **View** list, choose **New view**.

4 In the **Velocity (spf)** toolbar, click  **Plot**.

The slice plot of the velocity clearly shows the recirculation zone behind the body. The result looks smooth which further supports the assumption that the resolution is acceptable.

Multislice: Velocity magnitude (m/s) Surface: 1 (1)



To calculate the entries in [Table 1](#), perform the following steps:

Global Evaluation 1

- 1 In the **Model Builder** window, expand the **Results > Derived Values** node.
- 2 Right-click **Results > Derived Values** and choose **Global Evaluation**.
- 3 In the **Settings** window for **Global Evaluation**, locate the **Expressions** section.
- 4 In the table, enter the following settings:

Expression	Unit	Description
Cd	1	Total drag coefficient
Ck	1	Front pressure coefficient
Cs	1	Slant pressure coefficient
Cb	1	Base pressure coefficient
Csf	1	Skin friction coefficient

- 5 Click  **Evaluate**.

The following steps reproduce [Figure 3](#):

Symmetry plane

- 1 In the **Results** toolbar, click  **More Datasets** and choose **Surface**.
- 2 In the **Settings** window for **Surface**, type *Symmetry plane* in the **Label** text field.
- 3 Locate the **Parameterization** section. From the **x- and y-axes** list, choose **yz-plane**.
- 4 Select Boundary 1 only.

Streamlines 2D

- 1 In the **Results** toolbar, click  **2D Plot Group**.
- 2 In the **Settings** window for **2D Plot Group**, type *Streamlines 2D* in the **Label** text field.
- 3 Locate the **Data** section. From the **Dataset** list, choose **Symmetry plane**.

Streamline 1

- 1 Right-click **Streamlines 2D** and choose **Streamline**.
- 2 In the **Settings** window for **Streamline**, locate the **Expression** section.
- 3 In the **x-component** text field, type *v*.
- 4 In the **y-component** text field, type *w*.
- 5 Locate the **Streamline Positioning** section. In the **Points** text field, type 34.
- 6 In the **Streamlines 2D** toolbar, click  **Plot**.

Streamlines 2D

- 1 In the **Model Builder** window, click **Streamlines 2D**.
- 2 Click  **Plot**.

Streamlines 3D

The following steps reproduce [Figure 4](#):

- 1 In the **Results** toolbar, click  **3D Plot Group**.
- 2 In the **Settings** window for **3D Plot Group**, type *Streamlines 3D* in the **Label** text field.
- 3 Locate the **Plot Settings** section. Clear the **Plot dataset edges** checkbox.

Surface 1

- 1 Right-click **Streamlines 3D** and choose **Surface**.
- 2 In the **Settings** window for **Surface**, locate the **Data** section.
- 3 From the **Dataset** list, choose **Plot surfaces**.
- 4 Locate the **Expression** section. In the **Expression** text field, type 1.

- 5 Locate the **Coloring and Style** section. From the **Coloring** list, choose **Uniform**.
- 6 From the **Color** list, choose **Gray**.

Streamline 1

- 1 In the **Model Builder** window, right-click **Streamlines 3D** and choose **Streamline**.
- 2 In the **Settings** window for **Streamline**, locate the **Streamline Positioning** section.
- 3 From the **Positioning** list, choose **Starting-point controlled**.
- 4 From the **Entry method** list, choose **Coordinates**.
- 5 In the **x** text field, type $\text{range}(0.01, 0.03, 0.16) \text{ range}(0.01, 0.03, 0.16) \text{ range}(0.01, 0.03, 0.16) \text{ range}(0.01, 0.03, 0.16)$.
- 6 In the **y** text field, type $-0.5*L$.
- 7 In the **z** text field, type $0.02*1^{\text{range}(1,6)} \ 0.08*1^{\text{range}(1,6)} \ 0.14*1^{\text{range}(1,6)} \ 0.2*1^{\text{range}(1,6)} \ 0.26*1^{\text{range}(1,6)}$.
- 8 Locate the **Coloring and Style** section. Find the **Line style** subsection. From the **Type** list, choose **Tube**.
- 9 In the **Tube radius expression** text field, type $k*1[s^2/m]$.
- 10 Select the **Radius scale factor** checkbox. In the associated text field, type $3e-4$.

Color Expression 1

Right-click **Streamline 1** and choose **Color Expression**.

Streamlines 3D

- 1 In the **Settings** window for **3D Plot Group**, locate the **Plot Settings** section.
- 2 From the **View** list, choose **New view**.
- 3 In the **Streamlines 3D** toolbar, click  **Plot**.

The following steps will reproduce figures [Figure 5](#) and [Figure 6](#):

Cut Plane 80 mm

- 1 In the **Results** toolbar, click  **Cut Plane**.
- 2 In the **Settings** window for **Cut Plane**, type **Cut Plane 80 mm** in the **Label** text field.
- 3 Locate the **Plane Data** section. From the **Plane** list, choose **zx-planes**.
- 4 In the **y-coordinate** text field, type $L+0.08$.

Cut Plane 200 mm

- 1 In the **Results** toolbar, click  **Cut Plane**.
- 2 In the **Settings** window for **Cut Plane**, type **Cut Plane 200 mm** in the **Label** text field.

3 Locate the **Plane Data** section. From the **Plane** list, choose **zx-planes**.

4 In the **y-coordinate** text field, type L+0.2.

Streamline: Velocity in xz-plane, 80 mm

1 In the **Results** toolbar, click  **3D Plot Group**.

2 In the **Settings** window for **3D Plot Group**, type Streamline: Velocity in xz-plane, 80 mm in the **Label** text field.

3 Click to expand the **Title** section.

Streamline Surface 1

1 In the **Streamline: Velocity in xz-plane, 80 mm** toolbar, click  **More Plots** and choose **Streamline Surface**.

2 In the **Settings** window for **Streamline Surface**, locate the **Data** section.

3 From the **Dataset** list, choose **Cut Plane 80 mm**.

4 Locate the **Streamline Positioning** section. From the **Positioning** list, choose **Uniform density**.

5 In the **Density level** text field, type 6.

6 Locate the **Coloring and Style** section. Find the **Line style** subsection. From the **Type** list, choose **Tube**.

7 Select the **Radius scale factor** checkbox. In the associated text field, type 0.0005.

8 Find the **Point style** subsection. From the **Type** list, choose **Arrow**.

9 Select the **Number of arrows** checkbox. In the associated text field, type 50.

10 From the **Arrow length** list, choose **Logarithmic**.

11 In the **Range quotient** text field, type 1000.

12 Select the **Scale factor** checkbox. In the associated text field, type 0.0015.

13 From the **Color** list, choose **Black**.

Filter 1

1 Right-click **Streamline Surface 1** and choose **Filter**.

2 In the **Settings** window for **Filter**, locate the **Element Selection** section.

3 In the **Logical expression for inclusion** text field, type $(x < 0.35) * (z < 0.45)$.

Surface 1

1 In the **Model Builder** window, right-click **Streamline: Velocity in xz-plane, 80 mm** and choose **Surface**.

2 In the **Settings** window for **Surface**, locate the **Data** section.

- 3 From the **Dataset** list, choose **Plot surfaces**.
- 4 Locate the **Expression** section. In the **Expression** text field, type 1.
- 5 Locate the **Coloring and Style** section. From the **Coloring** list, choose **Uniform**.
- 6 From the **Color** list, choose **Gray**.

Streamline: Velocity in xz-plane, 80 mm

- 1 In the **Model Builder** window, click **Streamline: Velocity in xz-plane, 80 mm**.
- 2 In the **Settings** window for **3D Plot Group**, locate the **Plot Settings** section.
- 3 From the **View** list, choose **New view**.
- 4 In the **Streamline: Velocity in xz-plane, 80 mm** toolbar, click  **Plot**.

Duplicate the last plot and modify the settings to obtain the results at 200 mm.

Streamline: Velocity in xz-plane, 200 mm

- 1 Right-click **Streamline: Velocity in xz-plane, 80 mm** and choose **Duplicate**.
- 2 In the **Model Builder** window, click **Streamline: Velocity in xz-plane, 80 mm I**.
- 3 In the **Settings** window for **3D Plot Group**, type **Streamline: Velocity in xz-plane, 200 mm** in the **Label** text field.

Streamline Surface 1

- 1 In the **Model Builder** window, click **Streamline Surface 1**.
- 2 In the **Settings** window for **Streamline Surface**, locate the **Data** section.
- 3 From the **Dataset** list, choose **Cut Plane 200 mm**.

Streamline: Velocity in xz-plane, 200 mm

- 1 In the **Model Builder** window, click **Streamline: Velocity in xz-plane, 200 mm**.
- 2 In the **Streamline: Velocity in xz-plane, 200 mm** toolbar, click  **Plot**.