



Model created in COMSOL Multiphysics 6.4

# Liquid-Cooled Prismatic Battery Pack

## *Introduction*

---

This tutorial models the temperature profile in a liquid-cooled prismatic battery pack during a high-rate charge.

The pack consists of 16 prismatic battery cells connected by busbars, placed on an aluminum plate containing four cooling channels. The battery pack is assumed to have two faulty cells, featuring higher ohmic resistance values in comparison to the remaining cells in the pack. All other battery cell properties are identical.

The **Battery Pack** interface using the **Two electrodes** model is used to set up the current conduction and cell chemistry in the jelly roll, current conductors and busbars. The heat transfer in the battery cells, busbars and cooling plate is modeled using the **Heat Transfer in Solids** interface, whereas the **Heat Transfer in Pipes** and the **Pipe Flow** interface are used to define the convective heat transfer in the cooling channels.

The single battery cell geometry and parameters are similar to that used in the Application Libraries example [Cooling of a Prismatic Battery](#).

---

**Note:** This model requires a Pipe Flow Module license.

---

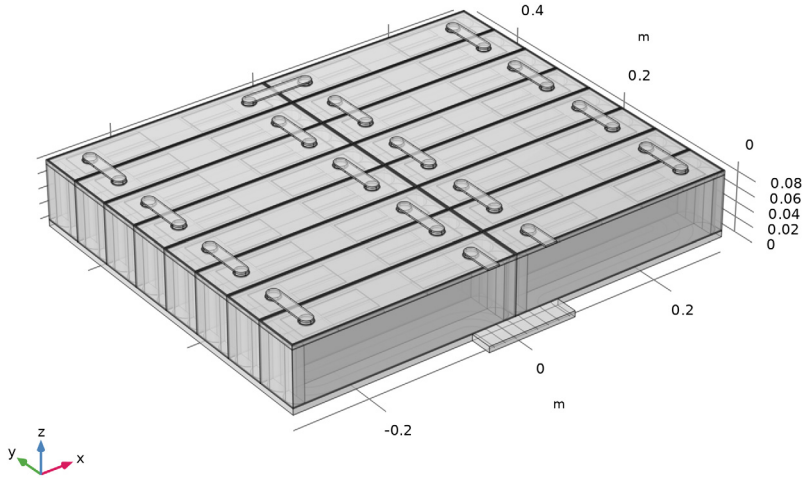

*Figure 1: Prismatic battery pack model geometry.*

[Figure 1](#) shows the model geometry. The prismatic battery pack consists of 16 prismatic battery cells connected by busbars. The battery pack is placed on a cooling plate with channels. The channels are defined as 1D edges.

The individual geometry parts that are used to build the battery pack geometry are shown in [Figure 2](#) through [Figure 4](#):

- [Figure 2](#) shows a single prismatic battery cell consisting of two jelly rolls. The different components of the single prismatic battery cell are discussed in detail in the Application Libraries example [Cooling of a Prismatic Battery](#).
- [Figure 3](#) shows 16 prismatic battery cells connected by busbars.
- [Figure 4](#) shows the cooling plate with channels.

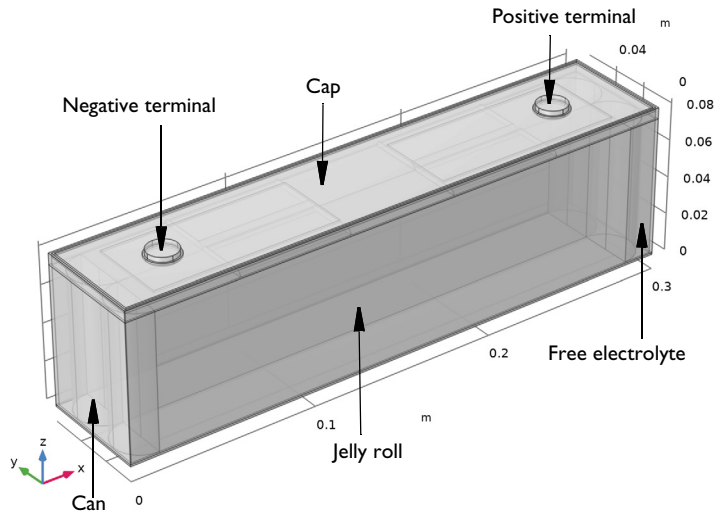

Figure 2: Single prismatic battery cell.

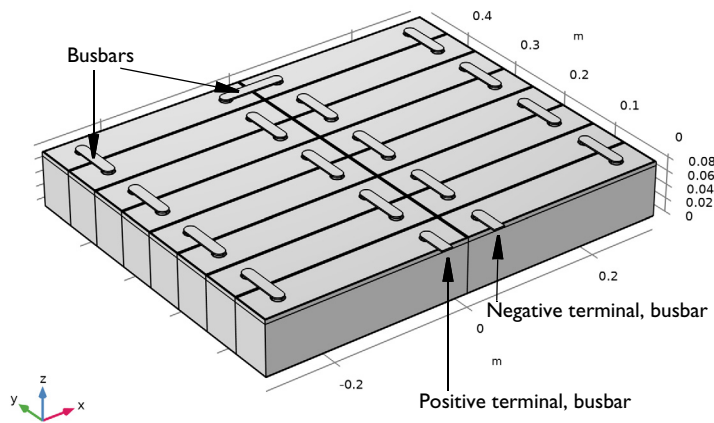
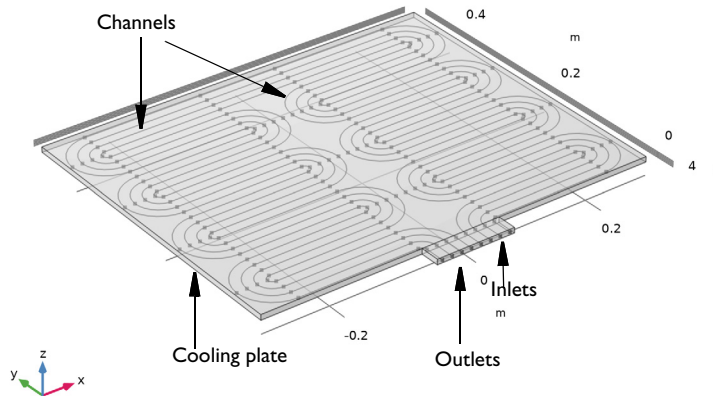

Figure 3: 16 prismatic battery cells connected by busbars.



*Figure 4: Cooling plate with 1D channels.*

The following domains and corresponding materials (taken from the **Built-in** material library, when available) are defined in the model geometry:

- Cooling plate (**Aluminum**)
- Liquid in channels (**Water**)
- Busbars (**Copper**)
- Cell can (**Aluminum**)
- Cap (**Aluminum**)
- Spacer (**Acrylic plastic**)
- Seal (**Acrylic plastic**)
- Battery cell terminals (**Copper/Aluminum**)
- Current collector plates (**Copper/Aluminum**)
- Free electrolyte (user-defined **Electrolyte** material)
- Metal foils (homogenized mixture of **Copper/Aluminum** and **Electrolyte**)
- Jelly roll (user-defined properties, including anisotropic thermal conductivities)

## ELECTROCHEMICAL MODEL

The **Battery Pack** interface with the **Two electrodes** model is used to set up the physics in the jelly roll (active layers of the battery cell), current conductors (current collectors plates, foils and terminals of the battery cell), and busbars of the prismatic battery pack.

In the model, the battery pack is assumed to have two faulty cells, that have a higher value of ohmic resistance when compared to the remaining cells in the pack. By enabling **Specify battery properties from materials** on the **Batteries** node, some model parameters (such as the initial positive and negative host capacities, and overpotential related properties on the **Voltage Losses** subnode) are defined using nodes defined under the **Materials** node in the model tree. By the usage of multiple material nodes, it is possible to assign different properties to individual battery cells. The higher ohmic resistance of the two faulty cells in the model are defined using a second material node.

The **Specify battery properties from materials** checkbox does not control any of the inputs belonging to the **Batteries > Negative Equilibrium Potential** and **Batteries > Positive Equilibrium Potential** subnodes. Instead, the negative and positive electrode materials are specified explicitly on these individual subnodes. The half-cell equilibrium potential curves for the two electrode materials, representing graphite and  $\text{LiFePO}_4$  (LFP) and identical for all cells in the pack, are taken from the **Battery** material library.

All cells in the pack are set to an initial cell state of charge (SOC) of 10%. A **Ground** condition is used at the negative terminal busbar boundary, and a **Current** condition corresponding to 4C cell current is defined on the positive terminal busbar boundary.

The negative and positive connectors, interconnecting the battery cell models and the current conduction domains, are set to the boundaries between the jelly roll and negative and positive foil domains, respectively.

## FLOW MODEL

The flow in the channels is described using the **Pipe Flow** interface. The inlet liquid mass flow rate is set to 0.01 kg/s using the **Mass flow rate** option.

## HEAT TRANSFER MODEL

The heat transfer in the channels is modeled using **Heat Transfer in Pipes** interface. For faster computation times, the discretization of the temperature dependent variable is set to linear.

The inlet and initial temperature of the liquid is set to 35°C. The **Wall Heat Transfer** node is used to set up heat exchange across the pipe wall. The external temperature is set up automatically by the use of **Pipe Wall Heat Transfer** multiphysics node. An **Internal Film**

**Resistance** subnode is added, to define the nature of heat transfer and compute the heat transfer coefficient.

**Heat Transfer in Solids** interface is used to model the temperature distribution in all domains of the battery pack. For faster computation times, the discretization for temperature is set to linear. The heat source from the **Battery Pack** interface is added by the use of **Electrochemical Heating** multiphysics node.

The metal foils bundles are treated as homogenized domains and defined using the **Porous Medium** node, where the thermal properties in the metal/electrolyte mix is defined by the use of **Porous Material** material nodes. The anisotropic thermal conductivity in the jelly roll is handled using **Battery Layers** node, where the in-layer and through-layer thermal conductivities are specified. Convective cooling conditions are added by the use of a **Heat Flux** node on all the top boundaries. The initial temperature of the entire battery pack is set to 35°C.

#### **STUDY**

The model is solved in two steps (a **Stationary** study step followed by a **Time Dependent** study step). The steady state fluid flow in the channels is solved for in the **Stationary** step, at the initial temperature of 35°C. The electrochemical and heat transfer model is solved for in the **Time Dependent** step. The final pack SOC of 80% is implicitly defined by end time in the **Time Dependent** step.

### *Results and Discussion*

---

Figure 5 shows the average, maximum, and minimum battery cell voltages versus time. The temperature variation in the battery pack leads to a variation in the voltage profile

across different cells in the battery pack. The cells with higher temperatures will have voltage profiles closer to the maximum cell voltage profile.

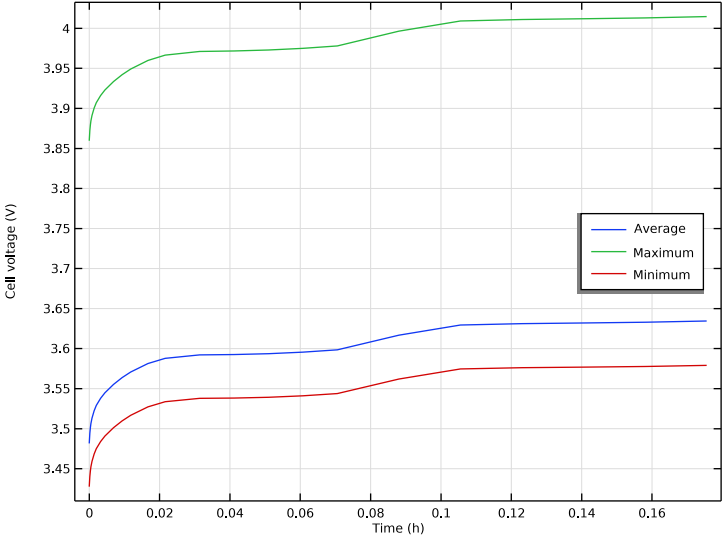

Figure 5: Battery cell voltages (average, maximum, and minimum) versus time.

Figure 6 shows the electric potential in the current conductors and busbars. The negative terminal busbar boundary has been grounded.

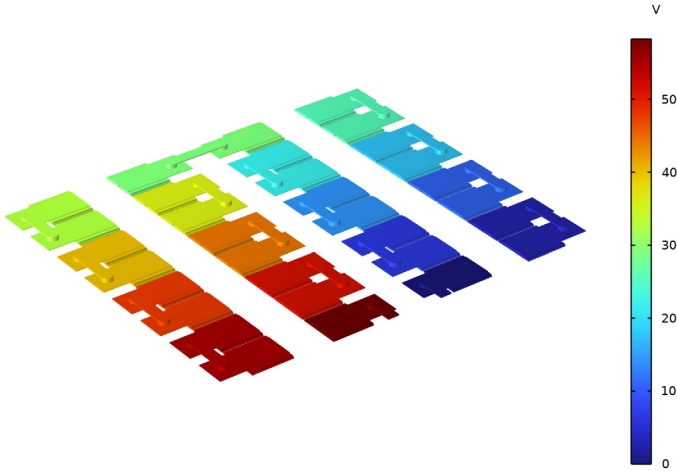

Figure 6: Electric potential in the current conductors and busbars.

Figure 7 shows the pressure distribution in the channels. The arrows represent the velocity field. Figure 8 shows the temperature distribution (at the end of the simulation) in the channels. The inlet temperature of the liquid in the channels is 35°C. The liquid outlet temperature is about 4°C higher than the liquid inlet temperature.

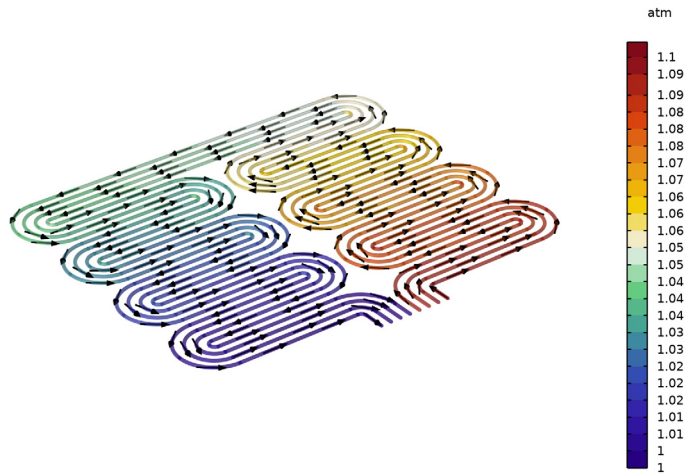

Figure 7: Pressure distribution in the channels. The arrows represent the velocity field.

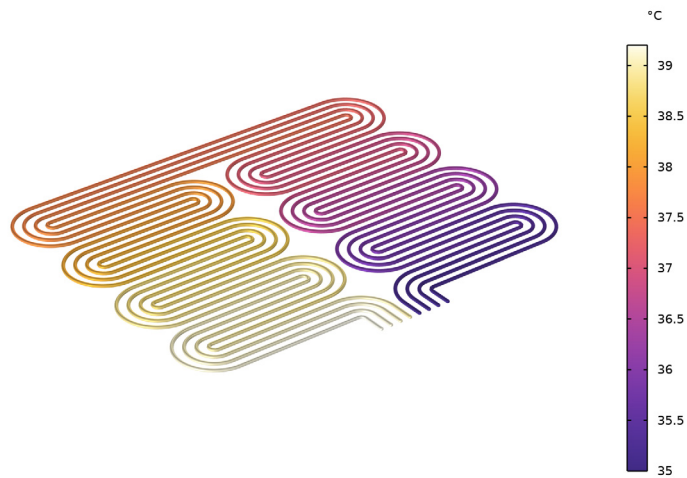
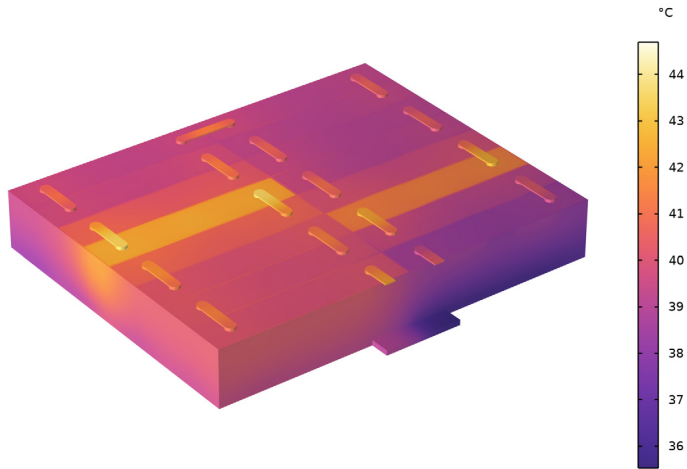
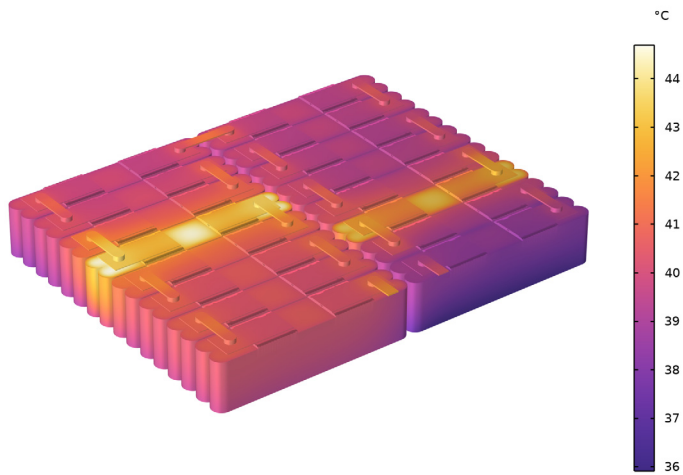

Figure 8: Temperature distribution in the channels.



*Figure 9: Temperature distribution in the entire battery pack.*



*Figure 10: Temperature distribution in the jelly roll, current conductors, and busbars.*

Figure 9 shows the temperature distribution (at the end of the simulation) in the entire battery pack. There is a variation of about 10°C in the battery pack. The two faulty cells that have a higher value of ohmic resistance than the remaining cells in the battery pack show increased heating and higher temperatures when compared to the adjacent cells in the pack.

Figure 10 shows the temperature distribution (at the end of the simulation) in the jelly roll, current conductors, and busbars. It is evident that the two faulty cells, their current conductors, and the busbars show increased heating and higher temperatures when compared to the adjacent cells in the pack.

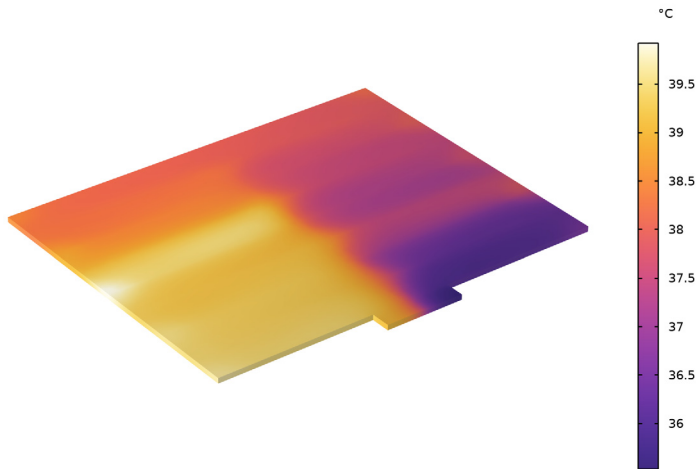

Figure 11: Temperature distribution in the cooling plate.

Figure 11 shows the temperature distribution (at the end of the simulation) in the cooling plate. The temperature distribution in the cooling plate is similar to that in the channels, with a variation of about 5°C across the cooling plate. Also, the cooling plate shows increased heating and higher temperatures near the faulty cells.

---

**Application Library path:** Battery\_Design\_Module/Thermal\_Management/  
prismatic\_battery\_pack\_cooling

---

## Modeling Instructions



---

From the **File** menu, choose **New**.

### NEW



In the **New** window, click  **Model Wizard**.

### MODEL WIZARD

- 1 In the **Model Wizard** window, click .
- 2 In the **Select Physics** tree, select **Electrochemistry > Batteries > Battery Pack (bp)**.
- 3 Click **Add**.
- 4 In the **Select Physics** tree, select **Fluid Flow > Single-Phase Flow > Pipe Flow (pfl)**.
- 5 Click **Add**.
- 6 In the **Select Physics** tree, select **Heat Transfer > Heat Transfer in Pipes (htp)**.
- 7 Click **Add**.
- 8 In the **Select Physics** tree, select **Heat Transfer > Heat Transfer in Solids (ht)**.
- 9 Click **Add**.
- 10 Click  **Study**.
- 11 In the **Select Study** tree, select **Empty Study**.
- 12 Click  **Done**.

### GEOMETRY: BATTERY PACK

Load the geometry sequence from a file as follows:

- 1 In the **Geometry** toolbar, click **Insert Sequence** and choose **Insert Sequence**.
- 2 Browse to the model's Application Libraries folder and double-click the file `prismatic_battery_pack_cooling_geom_sequence.mph`.
- 3 In the **Insert Sequence** dialog, click **OK**.
- 4 In the **Model Builder** window, under **Component 1 (comp1)** click **Geometry 1**.
- 5 In the **Settings** window for **Geometry**, type `Geometry: Battery Pack` in the **Label** text field.
- 6 In the **Geometry** toolbar, click  **Build All**.
- 7 Click the  **Transparency** button in the **Graphics** toolbar.

- 8 Click the  **Zoom Extents** button in the **Graphics** toolbar.

The prismatic battery pack consists of 16 prismatic battery cells connected by busbars, placed on a cooling plate with four channels. The channels are modeled as edges.

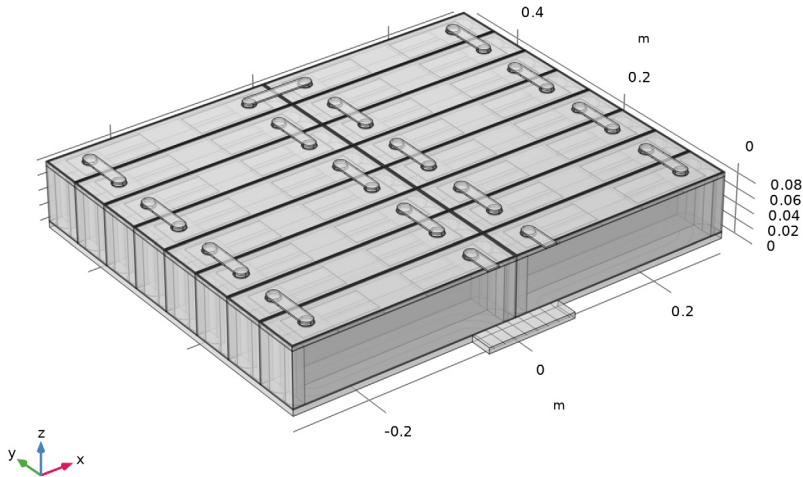

- 9 Locate the **Cleanup** section. Clear the **Automatic detection of small details** checkbox.
- 10 In the **Model Builder** window, collapse the **Geometry: Battery Pack** node.

## GLOBAL DEFINITIONS

### *Geometry Parameters*



Some parameters were imported with the geometry sequence.

- 1 In the **Model Builder** window, under **Global Definitions** click **Parameters I**.
- 2 In the **Settings** window for **Parameters**, type Geometry Parameters in the **Label** text field.

### *Physics Parameters*



Add additional parameters for setting up the physics as follows:

- 1 In the **Home** toolbar, click  **Parameters** and choose **Add > Parameters**.
- 2 In the **Settings** window for **Parameters**, type Physics Parameters in the **Label** text field.

- 3 Locate the **Parameters** section. Click  **Load from File**.
- 4 Browse to the model's Application Libraries folder and double-click the file `prismatic_battery_cooling_physics_parameters.txt`.
- 5 Click  **Load from File**.
- 6 Browse to the model's Application Libraries folder and double-click the file `prismatic_battery_pack_cooling_physics_parameters.txt`.

### ADD MATERIAL

Add data for the graphite and LFP electrode from the **Battery** material library, as **Global** materials. Additional materials which will be assigned to different domains of the prismatic battery pack, will be added later.

- 1 In the **Materials** toolbar, click  **Add Material** to open the **Add Material** window.
- 2 Go to the **Add Material** window.
- 3 In the tree, select **Battery** > **Electrodes** > **Graphite, LixC6 MCMB (Negative, Li-ion Battery)**.
- 4 Right-click and choose **Add to Global Materials**.
- 5 In the tree, select **Battery** > **Electrodes** > **LFP, LiFePO4 (Positive, Li-ion Battery)**.
- 6 Right-click and choose **Add to Global Materials**.
- 7 In the **Materials** toolbar, click  **Add Material** to close the **Add Material** window.

### DEFINITIONS

#### *Variables 1*

Add some variables as follows:

- 1 In the **Model Builder** window, under **Component 1 (comp1)** right-click **Definitions** and choose **Variables**.
- 2 In the **Settings** window for **Variables**, locate the **Variables** section.
- 3 Click  **Load from File**.
- 4 Browse to the model's Application Libraries folder and double-click the file `prismatic_battery_pack_cooling_physics_variables.txt`.

### MULTIPHYSICS

Before we set up the physics, add the required **Multiphysics** coupling nodes.

#### *Pipe Wall Heat Transfer 1 (pwhtc1)*

In the **Physics** toolbar, click  **Multiphysics Couplings** and choose **Edge** > **Pipe Wall Heat Transfer**.

### *Electrochemical Heating I (echI)*

In the **Physics** toolbar, click  **Multiphysics Couplings** and choose **Domain > Electrochemical Heating**.

### **BATTERY PACK (BP)**

Start setting up the physics, starting with the electrochemical model. The **Battery Pack** interface using the **Two electrodes** model is used to set up the physics in the jelly roll, current conductors and busbars.

- 1 In the **Model Builder** window, under **Component 1 (comp1)** click **Battery Pack (bp)**.
- 2 In the **Settings** window for **Battery Pack**, locate the **Domain Selection** section.
- 3 From the **Selection** list, choose **Jelly Roll, Current Conductors and Busbars (Batteries and Busbars)**.

### *Batteries*

- 1 In the **Model Builder** window, under **Component 1 (comp1) > Battery Pack (bp)** click **Batteries**.
- 2 In the **Settings** window for **Batteries**, locate the **Domain Selection** section.
- 3 From the **Selection** list, choose **Jelly Roll (Battery Cell 1) (Batteries and Busbars)**.
- 4 Locate the **Battery Pack Settings** section. From the **Model** list, choose **Two electrodes**.
- 5 Select the **Specify battery properties from materials** checkbox.

The checkbox **Specify battery properties from materials** allows to automatically set up some inputs from a material specified in the **Materials** node, that has been assigned to the selection of the **Batteries** node. This jelly roll material will be added later in the **Materials** node.

- 6 Locate the **Initial Cell Charge Distribution** section. In the  $\text{SOC}_{\text{cell},0}$  text field, type `SOC_init`.

### *Negative Equilibrium Potential I*

Specify the negative electrode material explicitly as follows:

- 1 In the **Model Builder** window, click **Negative Equilibrium Potential 1**.
- 2 In the **Settings** window for **Negative Equilibrium Potential**, locate the **Material** section.
- 3 From the **Electrode material** list, choose **Graphite, LixC6 MCMB (Negative, Li-ion Battery) (mat1)**.

### *Positive Equilibrium Potential I*

Similarly, specify the positive electrode material explicitly.

- 1 In the **Model Builder** window, click **Positive Equilibrium Potential 1**.
- 2 In the **Settings** window for **Positive Equilibrium Potential**, locate the **Material** section.
- 3 From the **Electrode material** list, choose **LFP, LiFePO4 (Positive, Li-ion Battery) (mat2)**.

#### *Voltage Losses 1*

- 1 In the **Model Builder** window, click **Voltage Losses 1**.
- 2 In the **Settings** window for **Voltage Losses**, locate the **Concentration Overpotential, Negative** section.
- 3 Select the **Include concentration overpotential, negative** checkbox.
- 4 Locate the **Concentration Overpotential, Positive** section. Select the **Include concentration overpotential, positive** checkbox.

#### *Current Conductors*

- 1 In the **Model Builder** window, under **Component 1 (comp1) > Battery Pack (bp)** click **Current Conductors**.
- 2 In the **Settings** window for **Current Conductors**, locate the **Domain Selection** section.
- 3 From the **Selection** list, choose **Current Conductors and Busbars (Batteries and Busbars)**.

#### *Ground 1*

- 1 In the **Physics** toolbar, click  **Attributes** and choose **Ground**.
- 2 In the **Settings** window for **Ground**, locate the **Boundary Selection** section.
- 3 From the **Selection** list, choose **Busbar Boundary, Negative Terminal (Batteries and Busbars)**.

#### *Current Conductors*

In the **Model Builder** window, click **Current Conductors**.

#### *Current 1*

- 1 In the **Physics** toolbar, click  **Attributes** and choose **Current**.
- 2 In the **Settings** window for **Current**, locate the **Boundary Selection** section.
- 3 From the **Selection** list, choose **Busbar Boundary, Positive Terminal (Batteries and Busbars)**.
- 4 Locate the **Electrode Current** section. In the  $I_{s,total}$  text field, type  $I_{app}$ .

#### *Negative Connectors*

- 1 In the **Model Builder** window, under **Component 1 (comp1) > Battery Pack (bp)** click **Negative Connectors**.
- 2 In the **Settings** window for **Negative Connectors**, locate the **Boundary Selection** section.

- 3 From the **Selection** list, choose **Negative Foils - Jelly Roll Boundaries (Battery Cell 1) (Batteries and Busbars)**.

#### *Positive Connectors*

- 1 In the **Model Builder** window, click **Positive Connectors**.
- 2 In the **Settings** window for **Positive Connectors**, locate the **Boundary Selection** section.
- 3 From the **Selection** list, choose **Positive Foils - Jelly Roll Boundaries (Battery Cell 1) (Batteries and Busbars)**.

### **PIPE FLOW (PFL)**

Next set up the physics for flow in the channels using the **Pipe Flow** interface. Again, the fluid material will be added later in the **Materials** node.

- 1 In the **Model Builder** window, under **Component 1 (comp1)** click **Pipe Flow (pfl)**.
- 2 In the **Settings** window for **Pipe Flow**, locate the **Edge Selection** section.
- 3 From the **Selection** list, choose **Channels (Cooling Plate and Channels)**.

#### *Pipe Properties 1*

- 1 In the **Model Builder** window, under **Component 1 (comp1) > Pipe Flow (pfl)** click **Pipe Properties 1**.
- 2 In the **Settings** window for **Pipe Properties**, locate the **Pipe Shape** section.
- 3 From the list, choose **Square**.
- 4 In the  $w_i$  text field, type s\_channels.

#### *Inlet 1*

- 1 In the **Physics** toolbar, click  **Points** and choose **Inlet**.
- 2 In the **Settings** window for **Inlet**, locate the **Point Selection** section.
- 3 From the **Selection** list, choose **Inlets (Cooling Plate and Channels)**.
- 4 Locate the **Inlet Specification** section. In the  $q_{m,0}$  text field, type M\_flow\_in.

### **HEAT TRANSFER IN PIPES (HTP)**

Next set up the physics for heat transfer in the channels using the **Heat Transfer in Pipes** interface. For faster computation times, the **Discretization** for temperature is set to **Linear**.

- 1 In the **Model Builder** window, under **Component 1 (comp1)** click **Heat Transfer in Pipes (htp)**.
- 2 In the **Settings** window for **Heat Transfer in Pipes**, locate the **Edge Selection** section.
- 3 From the **Selection** list, choose **Channels (Cooling Plate and Channels)**.

- 4 Click to expand the **Discretization** section. From the **Temperature** list, choose **Linear**.

#### *Heat Transfer I*

- 1 In the **Model Builder** window, under **Component 1 (comp1) > Heat Transfer in Pipes (htp)** click **Heat Transfer I**.
- 2 In the **Settings** window for **Heat Transfer**, locate the **Heat Convection and Conduction** section.
- 3 From the  $u$  list, choose **Tangential velocity (pfl)**.

#### *Pipe Properties I*

- 1 In the **Model Builder** window, click **Pipe Properties I**.
- 2 In the **Settings** window for **Pipe Properties**, locate the **Pipe Shape** section.
- 3 From the list, choose **Square**.
- 4 In the  $w_i$  text field, type `s_channels`.

#### *Temperature I*

- 1 In the **Model Builder** window, click **Temperature I**.
- 2 In the **Settings** window for **Temperature**, locate the **Temperature** section.
- 3 In the  $T_{in}$  text field, type `T0`.

#### *Initial Values I*

- 1 In the **Model Builder** window, click **Initial Values I**.
- 2 In the **Settings** window for **Initial Values**, locate the **Initial Values** section.
- 3 In the  $T$  text field, type `T0`.

#### *Heat Outflow I*

- 1 In the **Physics** toolbar, click  **Points** and choose **Heat Outflow**.
- 2 In the **Settings** window for **Heat Outflow**, locate the **Point Selection** section.
- 3 From the **Selection** list, choose **Outlets (Cooling Plate and Channels)**.

#### *Wall Heat Transfer I*

The **Wall Heat Transfer** node is used to set up heat exchange across the pipe wall. The external temperature is set up automatically from the **Pipe Wall Heat Transfer** multiphysics node. An **Internal Film Resistance** subnode is added, to define the nature of heat transfer and compute the heat transfer coefficient.

- 1 In the **Physics** toolbar, click  **Edges** and choose **Wall Heat Transfer**.
- 2 In the **Settings** window for **Wall Heat Transfer**, locate the **Edge Selection** section.
- 3 From the **Selection** list, choose **Channels (Cooling Plate and Channels)**.

### *Internal Film Resistance*

In the **Physics** toolbar, click  **Attributes** and choose **Internal Film Resistance**.

### **HEAT TRANSFER IN SOLIDS (HT)**

Finally set up the physics for heat transfer in all domains using the **Heat Transfer in solids** interface. For faster computation times, the **Discretization** for temperature is set to **Linear**. The heat source from the **Battery Pack** interface is added from the **Electrochemical Heating** multiphysics node. Again, all required materials will be added later in the **Materials** node.

- 1 In the **Model Builder** window, under **Component 1 (comp1)** click **Heat Transfer in Solids (ht)**.
- 2 In the **Settings** window for **Heat Transfer in Solids**, click to expand the **Discretization** section.
- 3 From the **Temperature** list, choose **Linear**.

### *Initial Values*

- 1 In the **Model Builder** window, under **Component 1 (comp1)** > **Heat Transfer in Solids (ht)** click **Initial Values 1**.
- 2 In the **Settings** window for **Initial Values**, locate the **Initial Values** section.
- 3 In the  $T^2$  text field, type  $T_0$ .

### *Porous Medium*

The foil domains are modeled as porous media, consisting of a mix of metal conductors and electrolyte.

- 1 In the **Physics** toolbar, click  **Domains** and choose **Porous Medium**.
- 2 In the **Settings** window for **Porous Medium**, locate the **Domain Selection** section.
- 3 From the **Selection** list, choose **Foils (Battery Cell 1) (Batteries and Busbars)**.

### *Battery Layers*

Define the heat transfer within the jelly roll as follows:

- 1 In the **Physics** toolbar, click  **Domains** and choose **Battery Layers**.
- 2 In the **Settings** window for **Battery Layers**, locate the **Domain Selection** section.
- 3 From the **Selection** list, choose **Jelly Roll (Battery Cell 1) (Batteries and Busbars)**.
- 4 Locate the **Battery Layers** section. From the **Layer configuration** list, choose **Flat-sided oval (prismatic)**.
- 5 In the  $k_{t1}$  text field, type  $kT\_batt\_t1$ .
- 6 In the  $k_{i1}$  text field, type  $kT\_batt\_i1$ .

- 7 In the  $\rho_{\text{eff}}$  text field, type rho\_batt.
- 8 In the  $C_{p,\text{eff}}$  text field, type Cp\_batt.

#### *Rectangular Block Selection 1*

- 1 In the **Model Builder** window, click **Rectangular Block Selection 1**.
- 2 In the **Settings** window for **Rectangular Block Selection**, locate the **Domain Selection** section.
- 3 From the **Selection** list, choose **Jelly Roll Rectangular Blocks (Battery Cell 1) (Batteries and Busbars)**.
- 4 Locate the **Battery Layers** section. From the **Through-layer direction** list, choose **y-axis**.

#### *Heat Flux 1*

- 1 In the **Physics** toolbar, click  **Boundaries** and choose **Heat Flux**.
- 2 In the **Settings** window for **Heat Flux**, locate the **Boundary Selection** section.
- 3 From the **Selection** list, choose **Pack Convective Boundaries (Batteries and Busbars)**.
- 4 Locate the **Heat Flux** section. From the **Flux type** list, choose **Convective heat flux**.
- 5 In the  $h$  text field, type htc.
- 6 In the  $T_{\text{ext}}$  text field, type T0.

### **MATERIALS**

Add all the materials required by the physics interfaces and assign them to appropriate domains or edges.

#### **ADD MATERIAL FROM LIBRARY**

In the **Home** toolbar, click  **Windows** and choose **Add Material from Library**.

#### **ADD MATERIAL**

- 1 Go to the **Add Material** window.
- 2 In the tree, select **Liquids and Gases > Liquids > Water**.
- 3 Click the **Add to Component** button in the window toolbar.

### **MATERIALS**

#### *Water (mat3)*

- 1 In the **Settings** window for **Material**, locate the **Geometric Entity Selection** section.
- 2 From the **Geometric entity level** list, choose **Edge**.
- 3 From the **Selection** list, choose **Channels (Cooling Plate and Channels)**.

## ADD MATERIAL

- 1 Go to the **Add Material** window.
- 2 In the tree, select **Built-in > Aluminum**.
- 3 Click the **Add to Component** button in the window toolbar.

## MATERIALS

### *Aluminum (mat4)*

- 1 In the **Settings** window for **Material**, locate the **Geometric Entity Selection** section.
- 2 From the **Selection** list, choose **Pack Aluminum Domains**.

## ADD MATERIAL

- 1 Go to the **Add Material** window.
- 2 In the tree, select **Built-in > Copper**.
- 3 Click the **Add to Component** button in the window toolbar.

## MATERIALS

### *Copper (mat5)*

- 1 In the **Settings** window for **Material**, locate the **Geometric Entity Selection** section.
- 2 From the **Selection** list, choose **Pack Copper Domains**.

## ADD MATERIAL

- 1 Go to the **Add Material** window.
- 2 In the tree, select **Built-in > Acrylic plastic**.
- 3 Click the **Add to Component** button in the window toolbar.
- 4 In the **Home** toolbar, click  **Add Material** to close the **Add Material** window.

## MATERIALS

### *Acrylic plastic (mat6)*

- 1 In the **Settings** window for **Material**, locate the **Geometric Entity Selection** section.
- 2 From the **Selection** list, choose **Spacer and Seal (Battery Cell 1) (Batteries and Busbars)**.

### *Electrolyte*

- 1 In the **Model Builder** window, right-click **Materials** and choose **Blank Material**.
- 2 In the **Settings** window for **Material**, type **Electrolyte** in the **Label** text field.

3 Locate the **Geometric Entity Selection** section. From the **Selection** list, choose **Free Electrolyte (Battery Cell 1) (Batteries and Busbars)**.

4 Locate the **Material Contents** section. In the table, enter the following settings:

Property	Variable	Value	Unit	Property group
Thermal conductivity	$k_{iso}$ ; $k_{ii} = k_{iso}$ , $k_{ij} = 0$	1	W/(m·K)	Basic
Density	$\rho$	1000	kg/m <sup>3</sup>	Basic
Heat capacity at constant pressure	$C_p$	1000	J/(kg·K)	Basic

*Porous Material - Homogenized Negative Foils*

1 Right-click **Materials** and choose **More Materials > Porous Material**.

2 In the **Settings** window for **Porous Material**, type Porous Material - Homogenized Negative Foils in the **Label** text field.

3 Locate the **Geometric Entity Selection** section. From the **Selection** list, choose **Negative Foils (Battery Cell 1) (Batteries and Busbars)**.

*Fluid 1 (pmat1.fluid1)*

1 Right-click **Porous Material - Homogenized Negative Foils** and choose **Fluid**.

2 In the **Settings** window for **Fluid**, locate the **Fluid Properties** section.

3 From the **Material** list, choose **Electrolyte (mat7)**.

*Solid 1 (pmat1.solid1)*

1 In the **Model Builder** window, right-click **Porous Material - Homogenized Negative Foils (pmat1)** and choose **Solid**.

2 In the **Settings** window for **Solid**, locate the **Solid Properties** section.

3 From the **Material** list, choose **Copper (mat5)**.

4 In the  $\theta_s$  text field, type  $\text{eps\_cc\_neg}$ .

*Porous Material - Homogenized Negative Foils (pmat1)*

1 In the **Model Builder** window, click **Porous Material - Homogenized Negative Foils (pmat1)**.

2 In the **Settings** window for **Porous Material**, locate the **Homogenized Properties** section.

3 In the table, enter the following settings:

Property	Variable	Value	Unit	Property group
Electric conductivity	sigma_iso ; sigma_ii = sigma_iso, sigma_ij = 0	eps_cc_ne g* 5.998e7 [S /m]	S/m	Basic

*Porous Material - Homogenized Positive Foils*

- 1 In the **Model Builder** window, right-click **Materials** and choose **More Materials > Porous Material**.
- 2 In the **Settings** window for **Porous Material**, type Porous Material - Homogenized Positive Foils in the **Label** text field.
- 3 Locate the **Geometric Entity Selection** section. From the **Selection** list, choose **Positive Foils (Battery Cell 1) (Batteries and Busbars)**.

*Fluid 1 (pmat2.fluid1)*

- 1 Right-click **Porous Material - Homogenized Positive Foils** and choose **Fluid**.
- 2 In the **Settings** window for **Fluid**, locate the **Fluid Properties** section.
- 3 From the **Material** list, choose **Electrolyte (mat7)**.

*Solid 1 (pmat2.solid1)*

- 1 In the **Model Builder** window, right-click **Porous Material - Homogenized Positive Foils (pmat2)** and choose **Solid**.
- 2 In the **Settings** window for **Solid**, locate the **Solid Properties** section.
- 3 From the **Material** list, choose **Aluminum (mat4)**.
- 4 In the  $\theta_s$  text field, type eps\_cc\_pos.

*Porous Material - Homogenized Positive Foils (pmat2)*

- 1 In the **Model Builder** window, click **Porous Material - Homogenized Positive Foils (pmat2)**.
- 2 In the **Settings** window for **Porous Material**, locate the **Homogenized Properties** section.

3 In the table, enter the following settings:

Property	Variable	Value	Unit	Property group
Electric conductivity	sigma_iso ; sigma_ii = sigma_iso, sigma_ij = 0	eps_cc_pos* 3.774e7 [S /m]	S/m	Basic

#### *Jelly Roll Material*

In this model, the battery pack is assumed to have two faulty cells, featuring higher ohmic resistance values in comparison to the remaining cells in the pack. All other battery cell properties are identical. Set up the jelly roll materials as follows:

- 1 In the **Model Builder** window, right-click **Materials** and choose **Blank Material**.
- 2 In the **Settings** window for **Material**, type Jelly Roll Material in the **Label** text field.
- 3 Locate the **Geometric Entity Selection** section. From the **Selection** list, choose **Jelly Roll (Battery Cell 1) (Batteries and Busbars)**.
- 4 Locate the **Material Contents** section. In the table, enter the following settings:

Property	Variable	Value	Unit	Property group
Initial negative host capacity	Q_host_negmat	Q_host_neg	C	Lumped battery, basic
Initial positive host capacity	Q_host_posmat	Q_host_pos	C	Lumped battery, basic
Ohmic overpotential at IC	eta_irICmat	eta_1C	V	Lumped battery, basic
Dimensionless charge exchange current, negative	J0_negmat	J0	I	Dimensionless charge exchange current
Dimensionless charge exchange current, positive	J0_posmat	J0	I	Dimensionless charge exchange current
Diffusion time constant, negative	tau_negmat	tau_neg	s	Diffusion time constant
Diffusion time constant, positive	tau_posmat	tau_pos	s	Diffusion time constant

#### *Jelly Roll Material, Faulty*

- 1 Right-click **Jelly Roll Material** and choose **Duplicate**.

- 2 In the **Settings** window for **Material**, type Jelly Roll Material, Faulty in the **Label** text field.
- 3 Locate the **Geometric Entity Selection** section. From the **Selection** list, choose **Faulty Jelly Roll**.
- 4 Locate the **Material Contents** section. In the table, enter the following settings:

Property	Variable	Value	Unit	Property group
Ohmic overpotential at IC	eta_ir Cmat	eta_1C_faulty	V	Lumped battery, basic

## PIPE FLOW (PFL)

### *Fluid Properties I*

Set the model input temperature in the **Pipe Flow** interface to be the initial temperature. The steady state fluid flow in the channels will be solved for in a **Stationary** study step only.

- 1 In the **Model Builder** window, under **Component 1 (comp1) > Pipe Flow (pfl)** click **Fluid Properties I**.
- 2 In the **Settings** window for **Fluid Properties**, locate the **Model Input** section.
- 3 In the  $T$  text field, type  $T_0$ .

## DEFINITIONS (COMPI)

Set up some probes for the cell voltage as follows:

### *Global Variable Probe: E\_cell average*

- 1 In the **Definitions** toolbar, click  **Probes** and choose **Global Variable Probe**.
- 2 In the **Settings** window for **Global Variable Probe**, type Global Variable Probe: E\_cell average in the **Label** text field.
- 3 Locate the **Expression** section. In the **Expression** text field, type  $bp.E\_cell\_avg$ .
- 4 Select the **Description** checkbox. In the associated text field, type Cell voltage, average.

### *Global Variable Probe: E\_cell maximum*

- 1 Right-click **Global Variable Probe: E\_cell average** and choose **Duplicate**.
- 2 In the **Settings** window for **Global Variable Probe**, type Global Variable Probe: E\_cell maximum in the **Label** text field.
- 3 Locate the **Expression** section. In the **Expression** text field, type  $bp.E\_cell\_max$ .

4 In the **Description** text field, type Cell voltage, maximum.

*Global Variable Probe: E\_cell minimum*

- 1 Right-click **Global Variable Probe: E\_cell maximum** and choose **Duplicate**.
- 2 In the **Settings** window for **Global Variable Probe**, type Global Variable Probe: E\_cell minimum in the **Label** text field.
- 3 Locate the **Expression** section. In the **Expression** text field, type bp.E\_cell\_min.
- 4 In the **Description** text field, type Cell voltage, minimum.

## **MESH 1**

Set up a user-defined mesh as follows:

- 1 In the **Model Builder** window, under **Component 1 (comp1)** click **Mesh 1**.
- 2 In the **Settings** window for **Mesh**, locate the **Sequence Type** section.
- 3 From the list, choose **User-controlled mesh**.
- 4 In the **Mesh** toolbar, click  **Clear Sequence**.

*Free Tetrahedral 1*

- 1 In the **Mesh** toolbar, click  **Free Tetrahedral**.
- 2 In the **Settings** window for **Free Tetrahedral**, locate the **Domain Selection** section.
- 3 From the **Geometric entity level** list, choose **Domain**.
- 4 From the **Selection** list, choose **Cooling Plate (Cooling Plate and Channels)**.

*Size 1*

- 1 Right-click **Free Tetrahedral 1** and choose **Size**.
- 2 In the **Settings** window for **Size**, locate the **Geometric Entity Selection** section.
- 3 From the **Geometric entity level** list, choose **Edge**.
- 4 From the **Selection** list, choose **Channels (Cooling Plate and Channels)**.
- 5 Locate the **Element Size** section. Click the **Custom** button.
- 6 Locate the **Element Size Parameters** section.
- 7 Select the **Maximum element size** checkbox. In the associated text field, type s\_channels.
- 8 Click  **Build Selected**.

*Free Tetrahedral 2*

- 1 In the **Mesh** toolbar, click  **Free Tetrahedral**.
- 2 In the **Settings** window for **Free Tetrahedral**, locate the **Domain Selection** section.

- 3 From the **Geometric entity level** list, choose **Domain**.
- 4 From the **Selection** list, choose  
**Battery Free Tet Domains (Battery Cell 1) (Batteries and Busbars)**.

#### *Size 1*

- 1 Right-click **Free Tetrahedral 2** and choose **Size**.
- 2 In the **Settings** window for **Size**, locate the **Geometric Entity Selection** section.
- 3 From the **Geometric entity level** list, choose **Edge**.
- 4 From the **Selection** list, choose  
**Jelly Roll Envelope Edges (Battery Cell 1) (Batteries and Busbars)**.
- 5 Locate the **Element Size** section. Click the **Custom** button.
- 6 Locate the **Element Size Parameters** section.
- 7 Select the **Maximum element size** checkbox. In the associated text field, type  $s\_can*2$ .
- 8 Click  **Build Selected**.

#### *Swept 1*

- 1 In the **Mesh** toolbar, click  **Swept**.
- 2 In the **Settings** window for **Swept**, locate the **Domain Selection** section.
- 3 From the **Geometric entity level** list, choose **Domain**.
- 4 From the **Selection** list, choose  
**Battery Upper Sweep Domains (Battery Cell 1) (Batteries and Busbars)**.

#### *Size 1*

- 1 Right-click **Swept 1** and choose **Size**.
- 2 In the **Settings** window for **Size**, locate the **Element Size** section.
- 3 Click the **Custom** button.
- 4 Locate the **Element Size Parameters** section.
- 5 Select the **Maximum element size** checkbox. In the associated text field, type  $s\_can$ .
- 6 Click  **Build Selected**.

#### *Free Tetrahedral 3*

- 1 In the **Mesh** toolbar, click  **Free Tetrahedral**.
- 2 In the **Settings** window for **Free Tetrahedral**, locate the **Domain Selection** section.
- 3 From the **Geometric entity level** list, choose **Domain**.
- 4 From the **Selection** list, choose  
**Battery Other Free Tet Domains (Battery Cell 1) (Batteries and Busbars)**.

5 Click  **Build Selected**.

#### *Swept 2*

- 1 In the **Mesh** toolbar, click  **Swept**.
- 2 In the **Settings** window for **Swept**, locate the **Domain Selection** section.
- 3 From the **Geometric entity level** list, choose **Domain**.
- 4 From the **Selection** list, choose **Extrude - Jelly Roll and Can (Battery Cell 1) (Batteries and Busbars)**.

#### *Distribution 1*

- 1 Right-click **Swept 2** and choose **Distribution**.
- 2 In the **Settings** window for **Distribution**, locate the **Domain Selection** section.
- 3 From the **Selection** list, choose **Extrude - Jelly Roll and Can (Battery Cell 1) (Batteries and Busbars)**.
- 4 Click  **Build Selected**.

#### *Free Tetrahedral 4*

- 1 In the **Mesh** toolbar, click  **Free Tetrahedral**.
- 2 In the **Settings** window for **Free Tetrahedral**, click  **Build Selected**.
- 3 In the **Model Builder** window, right-click **Mesh 1** and choose **Build All**.

### **STUDY 1**

The model is now ready for solving. Add a **Stationary** study step followed by a **Time Dependent** study step. The **Pipe Flow** interface (fluid flow in the channels) will be solved for in the **Stationary** study step only.

#### *Step 1: Stationary*

- 1 In the **Study** toolbar, click  **Stationary**.
- 2 In the **Settings** window for **Stationary**, locate the **Physics and Variables Selection** section.
- 3 In the **Solve for** column of the table, under **Component 1 (comp1)**, clear the checkboxes for **Heat Transfer in Pipes (htp)** and **Heat Transfer in Solids (ht)**.
- 4 In the **Solve for** column of the table, under **Component 1 (comp1) > Multiphysics**, clear the checkboxes for **Pipe Wall Heat Transfer 1 (pwhtc1)** and **Electrochemical Heating 1 (ech1)**.

#### *Step 2: Time Dependent*



- 1 In the **Study** toolbar, click  **Time Dependent**.

- 2 In the **Settings** window for **Time Dependent**, locate the **Physics and Variables Selection** section.
- 3 In the **Solve for** column of the table, under **Component 1 (comp1)**, clear the checkbox for **Pipe Flow (pfl)**.
- 4 Locate the **Study Settings** section. From the **Time unit** list, choose **h**.
- 5 In the **Output times** text field, type `range(0,0.1/C_rate,SOC_window/C_rate)`.
- 6 In the **Study** toolbar, click  **Compute**.

## RESULTS

Set the **Preferred units** to be used for temperature in the plots. Some plots are created by default. Analyze them and create a few additional plots as follows:

### *Preferred Units 1*

- 1 In the **Results** toolbar, click  **Configurations** and choose **Preferred Units**.
- 2 In the **Settings** window for **Preferred Units**, locate the **Units** section.
- 3 Click  **Add Physical Quantity**.
- 4 In the **Physical Quantity** dialog, select **General > Temperature (K)** in the tree.
- 5 Click **OK**.
- 6 In the **Settings** window for **Preferred Units**, locate the **Units** section.
- 7 Click  **Add Physical Quantity**.
- 8 In the **Physical Quantity** dialog, select **General > Pressure (Pa)** in the tree.
- 9 Click **OK**.
- 10 In the **Settings** window for **Preferred Units**, locate the **Units** section.
- 11 In the table, enter the following settings:

Quantity	Unit	Preferred unit
Temperature	K	°C
Pressure	Pa	atm

- 12 Click  **Apply**.

### *Jelly Roll Voltage Probe*

- 1 In the **Model Builder** window, under **Results** click **Probe Plot Group 1**.
- 2 In the **Settings** window for **ID Plot Group**, type `Jelly Roll Voltage Probe` in the **Label** text field.
- 3 Locate the **Plot Settings** section.

- 4 Select the **y-axis label** checkbox. In the associated text field, type **Cell voltage (V)**.
- 5 Locate the **Legend** section. From the **Position** list, choose **Middle right**.

*Probe Table Graph 1*

- 1 In the **Model Builder** window, expand the **Jelly Roll Voltage Probe** node, then click **Probe Table Graph 1**.
- 2 In the **Settings** window for **Table Graph**, click to expand the **Legends** section.
- 3 From the **Legends** list, choose **Manual**.
- 4 In the table, enter the following settings:



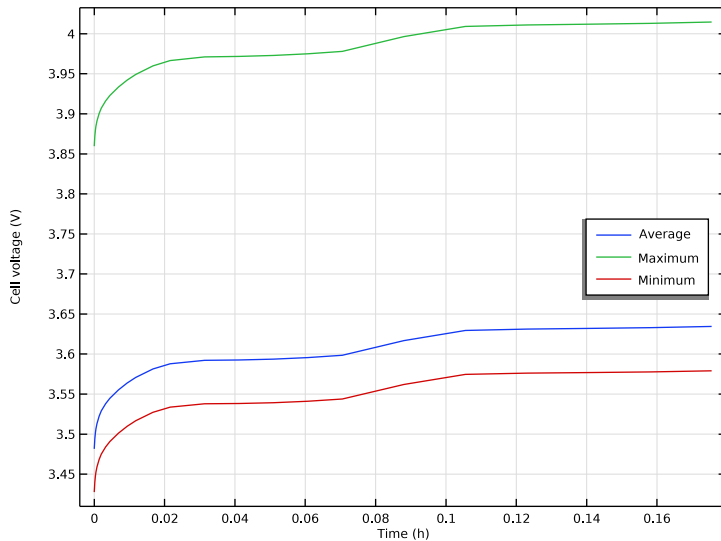

Legends
Average
Maximum
Minimum

- 5 In the **Jelly Roll Voltage Probe** toolbar, click  **Plot**.



*Electric Potential - Current Conductors and Busbars*

- 1 In the **Model Builder** window, under **Results** click **Electric Potential (bp)**.
- 2 In the **Settings** window for **3D Plot Group**, type **Electric Potential - Current Conductors and Busbars** in the **Label** text field.
- 3 Click to expand the **Title** section. From the **Title type** list, choose **None**.

- 4 Locate the **Plot Settings** section. Clear the **Plot dataset edges** checkbox.
- 5 Locate the **Color Legend** section. Select the **Show units** checkbox.
- 6 Click the  **Transparency** button in the **Graphics** toolbar.
- 7 Click the  **Show Grid** button in the **Graphics** toolbar.
- 8 Click the  **Show Axis Orientation** button in the **Graphics** toolbar.
- 9 Click the  **Zoom Extents** button in the **Graphics** toolbar.
- 10 In the **Electric Potential - Current Conductors and Busbars** toolbar, click  **Plot**.

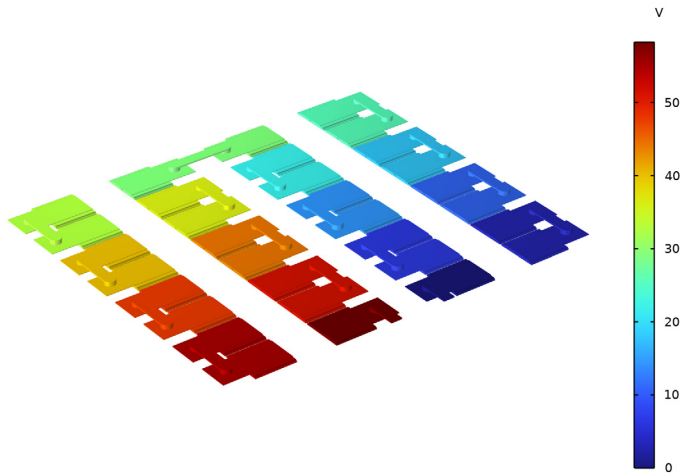

#### *Pressure - Channels*

- 1 In the **Model Builder** window, under **Results** click **Pressure (pfl)**.
- 2 In the **Settings** window for **3D Plot Group**, type Pressure - Channels in the **Label** text field.
- 3 Click to expand the **Title** section. From the **Title type** list, choose **None**.
- 4 Locate the **Plot Settings** section. Clear the **Plot dataset edges** checkbox.
- 5 Locate the **Color Legend** section. Select the **Show units** checkbox.

#### *Transparency I*

- 1 In the **Model Builder** window, expand the **Pressure - Channels** node.
- 2 Right-click **Line 1** and choose **Transparency**.



### Arrow Line 1

- 1 In the **Model Builder** window, right-click **Pressure - Channels** and choose **Arrow Line**.
- 2 In the **Settings** window for **Arrow Line**, click **Replace Expression** in the upper-right corner of the **Expression** section. From the menu, choose **Component 1 (comp1) > Pipe Flow > pfl.vX,pfl.vY,pfl.vZ - Velocity**.
- 3 Locate the **Coloring and Style** section. From the **Arrow base** list, choose **Center**.
- 4 Select the **Scale factor** checkbox. In the associated text field, type 0.06.
- 5 From the **Color** list, choose **Black**.

### Selection 1

- 1 Right-click **Arrow Line 1** and choose **Selection**.
- 2 In the **Settings** window for **Selection**, locate the **Selection** section.
- 3 From the **Selection** list, choose **Channels (Cooling Plate and Channels)**.

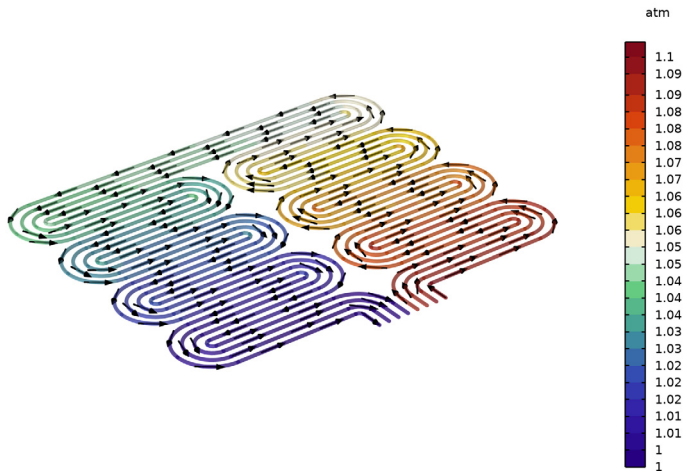

### Pressure - Channels

- 1 Click the  **Zoom Extents** button in the **Graphics** toolbar.
- 2 In the **Model Builder** window, under **Results** click **Pressure - Channels**.
- 3 In the **Pressure - Channels** toolbar, click  **Plot**.



### Temperature - Channels

- 1 In the **Model Builder** window, under **Results** click **Temperature (htp)**.

- 2 In the **Settings** window for **3D Plot Group**, type Temperature - Channels in the **Label** text field.
- 3 Locate the **Title** section. From the **Title type** list, choose **None**.
- 4 Locate the **Plot Settings** section. Clear the **Plot dataset edges** checkbox.
- 5 Locate the **Color Legend** section. Select the **Show units** checkbox.
- 6 Click the  **Zoom Extents** button in the **Graphics** toolbar.
- 7 In the **Temperature - Channels** toolbar, click  **Plot**.

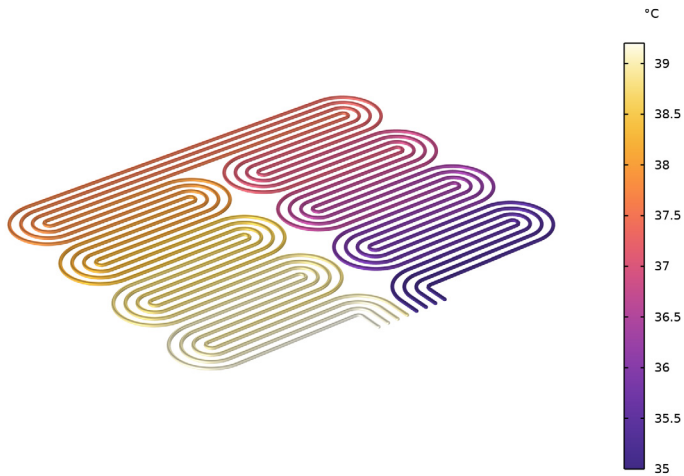

#### *Temperature - Full Geometry*

- 1 In the **Model Builder** window, under **Results** click **Temperature (ht)**.
- 2 In the **Settings** window for **3D Plot Group**, type Temperature - Full Geometry in the **Label** text field.
- 3 Locate the **Title** section. From the **Title type** list, choose **None**.
- 4 Locate the **Plot Settings** section. Clear the **Plot dataset edges** checkbox.
- 5 Locate the **Color Legend** section. Select the **Show units** checkbox.
- 6 Click the  **Zoom Extents** button in the **Graphics** toolbar.

7 In the **Temperature - Full Geometry** toolbar, click  **Plot**.

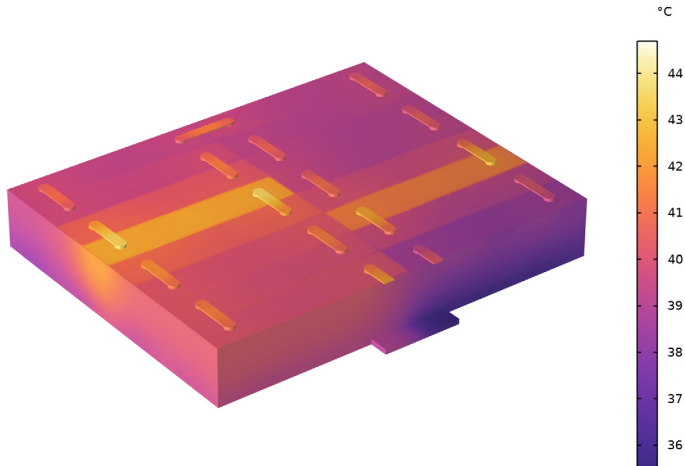

#### *Temperature - Jelly Roll, Current Conductors and Busbars*

- 1 Right-click **Temperature - Full Geometry** and choose **Duplicate**.
- 2 In the **Settings** window for **3D Plot Group**, type **Temperature - Jelly Roll, Current Conductors and Busbars** in the **Label** text field.

#### *Selection 1*

- 1 In the **Model Builder** window, expand the **Temperature - Jelly Roll, Current Conductors and Busbars** node.
- 2 Right-click **Volume 1** and choose **Selection**.
- 3 In the **Settings** window for **Selection**, locate the **Selection** section.
- 4 From the **Selection** list, choose **Jelly Roll, Current Conductors and Busbars (Batteries and Busbars)**.

#### *Temperature - Jelly Roll, Current Conductors and Busbars*

- 1 Click the  **Zoom Extents** button in the **Graphics** toolbar.
- 2 In the **Model Builder** window, under **Results** click **Temperature - Jelly Roll, Current Conductors and Busbars**.

- 3 In the **Temperature - Jelly Roll, Current Conductors and Busbars** toolbar, click  **Plot**.

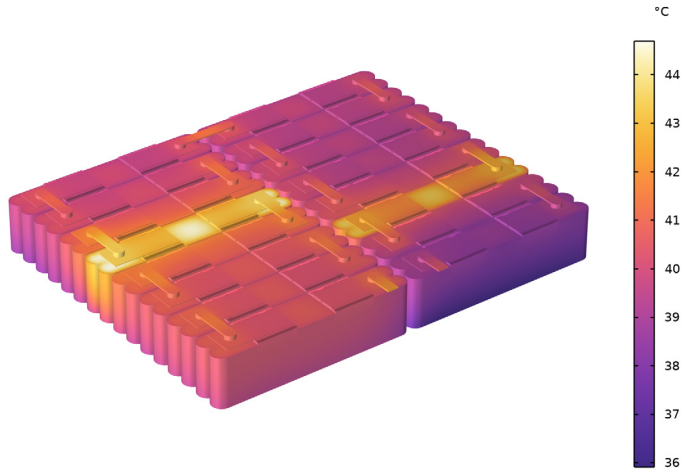

#### *Temperature - Cooling Plate*

- 1 Right-click **Temperature - Jelly Roll, Current Conductors and Busbars** and choose **Duplicate**.
- 2 In the **Settings** window for **3D Plot Group**, type **Temperature - Cooling Plate** in the **Label** text field.
- 3 In the **Model Builder** window, expand the **Temperature - Cooling Plate** node.

#### *Selection 1*

- 1 In the **Model Builder** window, expand the **Results > Temperature - Cooling Plate > Volume 1** node, then click **Selection 1**.
- 2 In the **Settings** window for **Selection**, locate the **Selection** section.
- 3 From the **Selection** list, choose **Cooling Plate (Cooling Plate and Channels)**.

#### *Temperature - Cooling Plate*

- 1 Click the  **Zoom Extents** button in the **Graphics** toolbar.
- 2 In the **Model Builder** window, under **Results** click **Temperature - Cooling Plate**.

3 In the **Temperature - Cooling Plate** toolbar, click  **Plot**.

