



Model created in COMSOL Multiphysics 6.4

Primary Current Distribution in a Lead-Acid Battery Grid Electrode

Introduction

This example demonstrates the use of the Primary Current Distribution interface for modeling current distributions in electrochemical cells.

In primary current distribution, the potential losses due to electrode kinetics and mass transport are assumed to be negligible, and ohmic losses govern the current distribution in the cell. Here you investigate the primary current distribution in a positive lead–acid battery grid electrode during a high load (100 A) discharge.

In a traditional lead–acid electrode, the porous electrode is supported by a metal grid that also provides electronic conduction throughout the electrode. Optimizing the design of the grid leads to increased performance and lifetime as well as reduced weight ([Ref. 1](#)).

Model Definition

The half-cell geometry consists of a grid and a lug of the same metal material, a matrix of porous electrodes residing within the grid, and an electrolyte domain. The geometry is shown in [Figure 1](#).

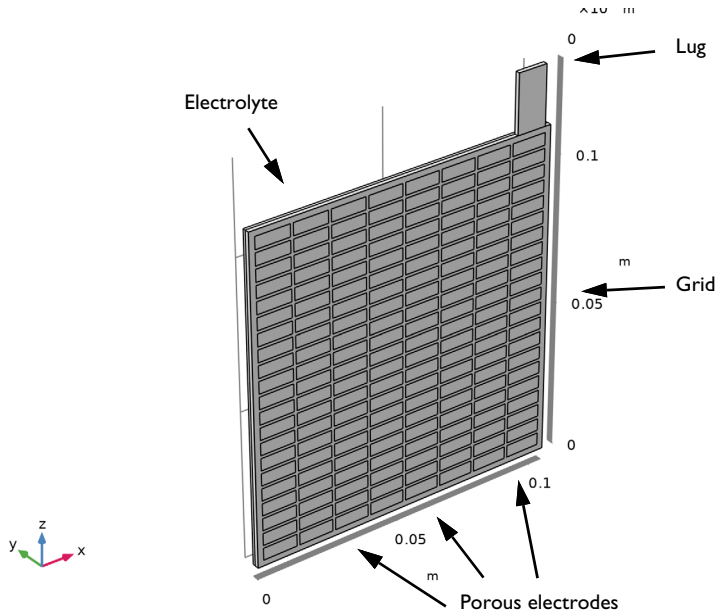

Figure 1: Modeled geometry.

The Primary Current Distribution interface is used to model the current distribution in the half cell. The potential in the electrolyte is set to zero at the external boundary that is parallel to the grid. A discharge current of 100 A is applied to the end of the lug. Isolation is used for all other boundaries.

The equilibrium potential for the positive electrode reaction versus a reversible hydrogen electrode (RHE) is used to relate the electrode to the electrolyte phase potential:

$$\phi_s + \phi_l = 1.7 \text{ V}$$

The above condition is applied as a constraint in the porous electrode domains.

The problem is solved using a Stationary study.

Results and Discussion

Figure 2 shows the electrolyte potential in the electrolyte and porous electrode domains. The potential drop is highest, roughly 0.2 V, in the area close to the lug.

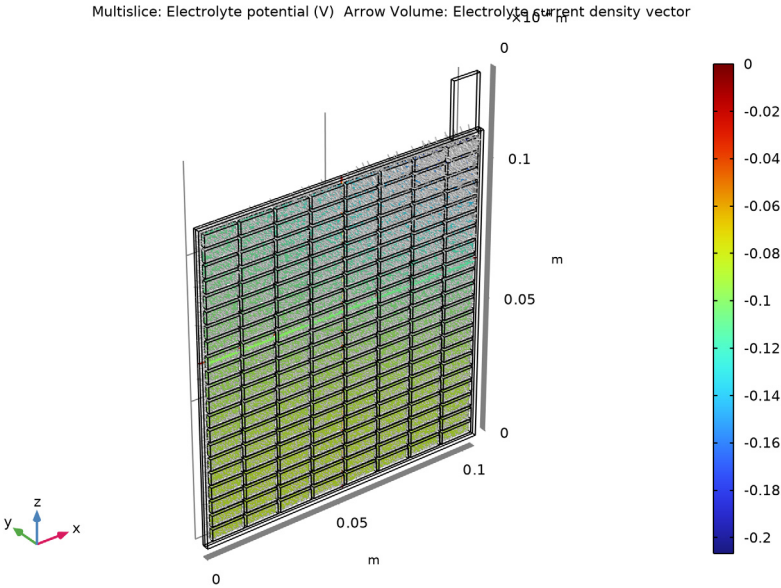

Figure 2: Electrolyte potential in the electrolyte and porous electrodes.

Figure 3 shows the electric potential in the grid and the lug. The potential difference between the corner of the grid closest to the lug and the far end corner is about 0.15 V.

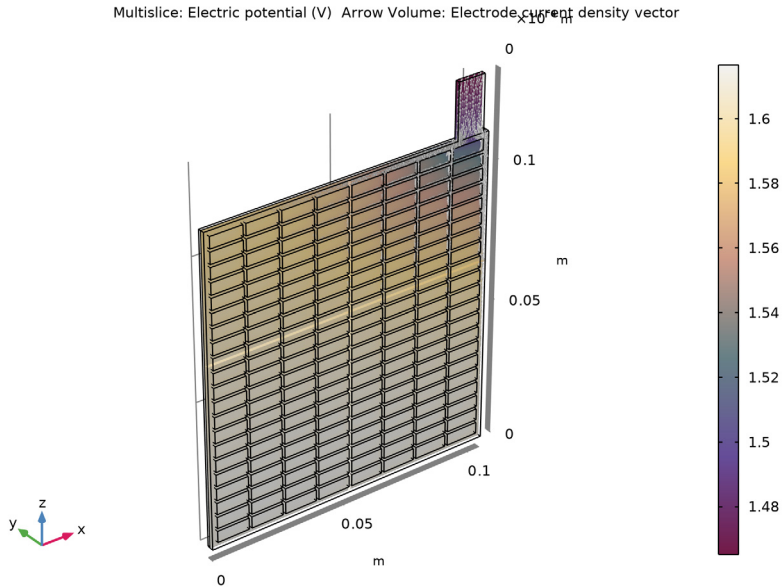

Figure 3: Electric potential in the grid and the lug.

Finally, the current density distribution in the electrolyte symmetry plane is plotted in Figure 4. The currents are about twice as high in the active region closest to the lug compared to the opposite corner of the cell.

In this case an improvement of the battery performance would be possible by making the frame of the grid thicker toward the lug corner, thereby achieving a more uniform current distribution.

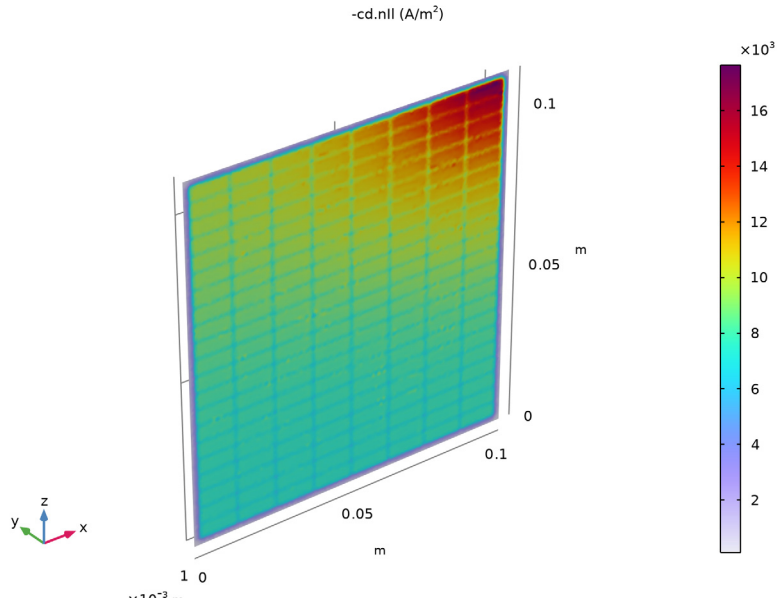

Figure 4: Electrolyte current density at the half-cell boundary.

Reference

1. K. Yamada, K.-I. Maeda, K. Sasaki, and T. Hirasawa “Computer-aided optimization of grid design for high-power lead–acid batteries,” *J. Power Sources*, selected papers from the Ninth European Lead Battery Conference, vol. 144, no. 2, pp. 352–357, 2005.

Application Library path: Battery_Design_Module/Batteries,_General/
primary_cd_grid



Modeling Instructions

From the **File** menu, choose **New**.

NEW

In the **New** window, click  **Model Wizard**.

MODEL WIZARD

- 1 In the **Model Wizard** window, click  **3D**.
- 2 In the **Select Physics** tree, select **Electrochemistry** > **Primary and Secondary Current Distribution** > **Primary Current Distribution (cd)**.
- 3 Click **Add**.
- 4 Click  **Study**.
- 5 In the **Select Study** tree, select **General Studies** > **Stationary**.
- 6 Click  **Done**.

GLOBAL DEFINITIONS



Parameters 1

- 1 In the **Model Builder** window, under **Global Definitions** click **Parameters 1**.
- 2 In the **Settings** window for **Parameters**, locate the **Parameters** section.
- 3 Click  **Load from File**.
- 4 Browse to the model's Application Libraries folder and double-click the file `primary_cd_grid_parameters.txt`.



GEOMETRY 1

Start building the geometry using a work plane representing the electrode grid plane.

Work Plane 1 (wp1)

- 1 In the **Geometry** toolbar, click  **Work Plane**.
- 2 In the **Settings** window for **Work Plane**, locate the **Plane Definition** section.
- 3 From the **Plane** list, choose **xz-plane**.
- 4 Click  **Go to Plane Geometry**.

Work Plane 1 (wp1) > Rectangle 1 (r1)

- 1 In the **Work Plane** toolbar, click  **Rectangle**.
- 2 In the **Settings** window for **Rectangle**, locate the **Size and Shape** section.
- 3 In the **Width** text field, type W.
- 4 In the **Height** text field, type H.
- 5 Click  **Build Selected**.



Work Plane 1 (wp1) > Plane Geometry

Draw one porous electrode section, then use it to create an array of porous electrodes.

Work Plane 1 (wp1) > Rectangle 2 (r2)

- 1 In the **Work Plane** toolbar, click  **Rectangle**.
- 2 In the **Settings** window for **Rectangle**, locate the **Size and Shape** section.
- 3 In the **Width** text field, type `W_porous`.
- 4 In the **Height** text field, type `H_porous`.
- 5 Locate the **Position** section. In the **xw** text field, type `s_frame`.
- 6 In the **yw** text field, type `s_frame`.



Work Plane 1 (wp1) > Array 1 (arr1)

- 1 In the **Work Plane** toolbar, click  **Transforms** and choose **Array**.
- 2 Select the object **r2** only.
- 3 In the **Settings** window for **Array**, locate the **Size** section.
- 4 In the **xw size** text field, type `N_x`.
- 5 In the **yw size** text field, type `N_z`.
- 6 Locate the **Displacement** section. In the **xw** text field, type `W_porous+s_grid`.
- 7 In the **yw** text field, type `H_porous+s_grid`.
- 8 Click  **Build Selected**.

Work Plane 1 (wp1) > Plane Geometry

Draw the lug as an additional rectangle. It has the same thickness as the electrode.

Work Plane 1 (wp1) > Rectangle 3 (r3)

- 1 In the **Work Plane** toolbar, click  **Rectangle**.
- 2 In the **Settings** window for **Rectangle**, locate the **Size and Shape** section.
- 3 In the **Width** text field, type `W_lug`.
- 4 In the **Height** text field, type `H_lug`.
- 5 Locate the **Position** section. In the **xw** text field, type `W-s_frame-W_lug`.
- 6 In the **yw** text field, type `H`.
- 7 Click  **Build Selected**.
- 8 Click the  **Zoom Extents** button in the **Graphics** toolbar.

Extrude 1 (ext1)

- 1 In the **Model Builder** window, under **Component 1 (comp1) > Geometry 1** right-click **Work Plane 1 (wp1)** and choose **Extrude**.
- 2 In the **Settings** window for **Extrude**, locate the **Distances** section.

3 In the table, enter the following settings:

Distances (m)

d_electrode

4 Click  **Build Selected**.

Electrolyte

Finalize the geometry by drawing the electrolyte domain.

1 In the **Geometry** toolbar, click  **Block**.

2 In the **Settings** window for **Block**, locate the **Size and Shape** section.

3 In the **Width** text field, type W.

4 In the **Depth** text field, type d_electrolyte.

5 In the **Height** text field, type H.

6 Locate the **Selections of Resulting Entities** section. Select the **Resulting objects selection** checkbox.

7 In the **Label** text field, type Electrolyte.

8 Click  **Build All Objects**.

9 Click the  **Zoom Extents** button in the **Graphics** toolbar.

The completed geometry should look as shown in the following figure:

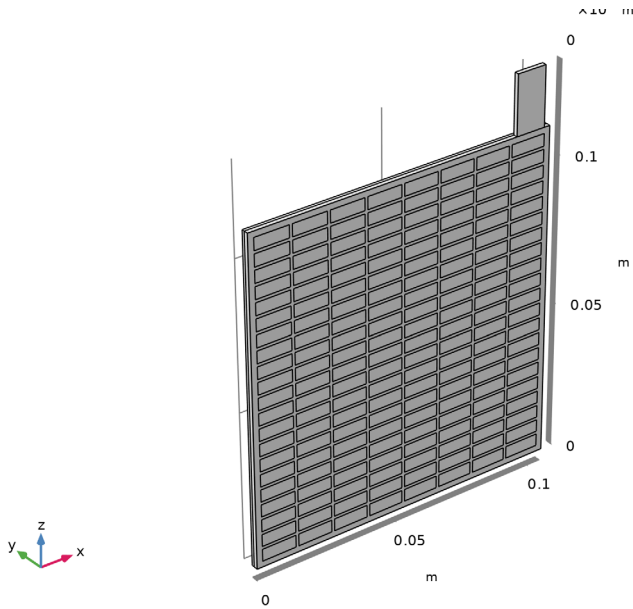

DEFINITIONS



Create a selection for the union of the grid and lug domains to facilitate setting up the model.

Grid + Lug

- 1 In the **Definitions** toolbar, click  **Explicit**.
- 2 Select Domains 1 and 171 only.
- 3 In the **Settings** window for **Explicit**, type **Grid + Lug** in the **Label** text field.

Use a Complement selection to select the porous electrodes.

Porous Electrodes

- 1 In the **Definitions** toolbar, click  **Complement**.
- 2 In the **Settings** window for **Complement**, locate the **Input Entities** section.
- 3 Under **Selections to invert**, click  **Add**.
- 4 In the **Add** dialog, in the **Selections to invert** list, choose **Grid + Lug** and **Electrolyte**.
- 5 Click **OK**.

- 6 In the **Settings** window for **Complement**, type Porous Electrodes in the **Label** text field.

PRIMARY CURRENT DISTRIBUTION (CD)

Current Conductor 1

- 1 In the **Physics** toolbar, click  **Domains** and choose **Current Conductor**.
- 2 In the **Settings** window for **Current Conductor**, locate the **Domain Selection** section.
- 3 From the **Selection** list, choose **Grid + Lug**.
- 4 Locate the **Electrode** section. From the σ_s list, choose **User defined**. In the associated text field, type sigma_metal.

Porous Electrode 1

- 1 In the **Physics** toolbar, click  **Domains** and choose **Porous Electrode**.
- 2 In the **Settings** window for **Porous Electrode**, locate the **Domain Selection** section.
- 3 From the **Selection** list, choose **Porous Electrodes**.
- 4 Locate the **Electrolyte Current Conduction** section. From the σ_1 list, choose **User defined**. In the associated text field, type sigma_electrolyte.
- 5 Locate the **Electrode Current Conduction** section. From the σ_s list, choose **User defined**. In the associated text field, type sigma_porous.

Porous Electrode Reaction 1

- 1 In the **Model Builder** window, click **Porous Electrode Reaction 1**.
- 2 In the **Settings** window for **Porous Electrode Reaction**, locate the **Equilibrium Potential** section.
- 3 In the E_{eq} text field, type 1.7.

Electrolyte 1

- 1 In the **Model Builder** window, under **Component 1 (comp1) > Primary Current Distribution (cd)** click **Electrolyte 1**.
- 2 In the **Settings** window for **Electrolyte**, locate the **Electrolyte** section.
- 3 From the σ_1 list, choose **User defined**. In the associated text field, type sigma_electrolyte.

Electrolyte Potential 1

- 1 In the **Physics** toolbar, click  **Boundaries** and choose **Electrolyte Potential**.
- 2 Select Boundary 9 only.



Electrode Current 1

- 1 In the **Physics** toolbar, click  **Boundaries** and choose **Electrode Current**.
- 2 Select Boundary 1000 only.
- 3 In the **Settings** window for **Electrode Current**, locate the **Electrode Current** section.
- 4 In the $I_{s,\text{total}}$ text field, type -100.



DEFINITIONS

The highest gradients in the model are to be expected at the edges between the porous electrode and the electrolyte. Create a selection of these edges to use later when setting up the mesh.



Adjacent 1

- 1 In the **Definitions** toolbar, click  **Adjacent**.
- 2 In the **Settings** window for **Adjacent**, locate the **Input Entities** section.
- 3 Under **Input selections**, click  **Add**.
- 4 In the **Add** dialog, select **Porous Electrodes** in the **Input selections** list.
- 5 Click **OK**.
- 6 In the **Settings** window for **Adjacent**, locate the **Output Entities** section.
- 7 From the **Geometric entity level** list, choose **Adjacent edges**.

Adjacent 2

- 1 In the **Definitions** toolbar, click  **Adjacent**.
- 2 In the **Settings** window for **Adjacent**, locate the **Input Entities** section.
- 3 Under **Input selections**, click  **Add**.
- 4 In the **Add** dialog, select **Electrolyte** in the **Input selections** list.
- 5 Click **OK**.
- 6 In the **Settings** window for **Adjacent**, locate the **Output Entities** section.
- 7 From the **Geometric entity level** list, choose **Adjacent edges**.

Intersection 1

- 1 In the **Definitions** toolbar, click  **Intersection**.
- 2 In the **Settings** window for **Intersection**, locate the **Geometric Entity Level** section.
- 3 From the **Level** list, choose **Edge**.
- 4 Locate the **Input Entities** section. Under **Selections to intersect**, click  **Add**.
- 5 In the **Add** dialog, in the **Selections to intersect** list, choose **Adjacent 1** and **Adjacent 2**.

6 Click **OK**.

MESH 1

Edge 1

- 1 In the **Mesh** toolbar, click  **More Generators** and choose **Edge**.
- 2 In the **Settings** window for **Edge**, locate the **Edge Selection** section.
- 3 From the **Selection** list, choose **Intersection 1**.

Size 1

- 1 Right-click **Edge 1** and choose **Size**.
- 2 In the **Settings** window for **Size**, locate the **Element Size** section.
- 3 Click the **Custom** button.
- 4 Locate the **Element Size Parameters** section.
- 5 Select the **Maximum element size** checkbox. In the associated text field, type `s_grid/2`.

Free Tetrahedral 1

- 1 In the **Mesh** toolbar, click  **Free Tetrahedral**.
- 2 In the **Model Builder** window, right-click **Mesh 1** and choose **Build All**.

STUDY 1

In the **Study** toolbar, click  **Compute**.

RESULTS

The electrolyte potential (Figure 2) and electrode potential versus ground (Figure 3) are plotted by default.

Electrolyte Current Density at the Half-cell Boundary

To create Figure 4, do the following steps.

- 1 In the **Results** toolbar, click  **3D Plot Group**.
- 2 In the **Settings** window for **3D Plot Group**, type **Electrolyte Current Density at the Half-cell Boundary** in the **Label** text field.
- 3 Locate the **Plot Settings** section. Clear the **Plot dataset edges** checkbox.

Surface 1

- 1 Right-click **Electrolyte Current Density at the Half-cell Boundary** and choose **Surface**.
- 2 In the **Settings** window for **Surface**, locate the **Expression** section.
- 3 In the **Expression** text field, type `-cd.nI1`.

4 Locate the **Coloring and Style** section. From the **Color table** list, choose **Prism**.

Selection 1

1 Right-click **Surface 1** and choose **Selection**.

2 Select Boundary 9 only.

3 In the **Electrolyte Current Density at the Half-cell Boundary** toolbar, click  **Plot**.