



Model created in COMSOL Multiphysics 6.4

Electrode Utilization in a Large-Format Lithium-Ion Battery Pouch Cell

Introduction

Large lithium-ion batteries are widely employed in electric vehicles and for stationary energy storage applications. In the (stacked) pouch battery cell design, all current exits the cell on the cell “tabs”, and as the cell size and power increases, the voltage gradients in the highly conductive metal foil current collectors may come into play, resulting in a nonuniform current distribution and electrode utilization in the cell. A nonuniform utilization results in suboptimal use of the battery electrodes and may also result in nonuniform and accelerated electrode aging.

This tutorial models the current distribution and electrode utilization in a large format lithium-ion battery pouch cell.

The model is in 3D. Note that all plots are scaled 100 times in the z direction due to the high aspect ratio of the geometric features.

For extended step-by-step instructions for this model, including several screen shots showing how to build it, see the book *Introduction to the Battery Design Module*.

Model Definition

[Figure 1](#) shows the model geometry. The geometry defines one foil-to-foil unit cell, stacking five layers in the z direction:

- Negative metal current collector foil: 10 μm , Cu (due to symmetry, half of this thickness is used in the model geometry)
- Negative electrode: 60 μm , graphite
- Separator: 30 μm
- Positive electrode: 60 μm , LMO
- Positive metal current collector foil: 10 μm , Al (due to symmetry, half of this thickness is used in the model geometry)
- The electrolyte is LiPF₆ in 3:7 EC:EMC
- Symmetry is assumed along the center of the cell

The positive and negative current terminals are located opposite to each other (but may easily be placed on the same side by altering the Geometry node in the model).

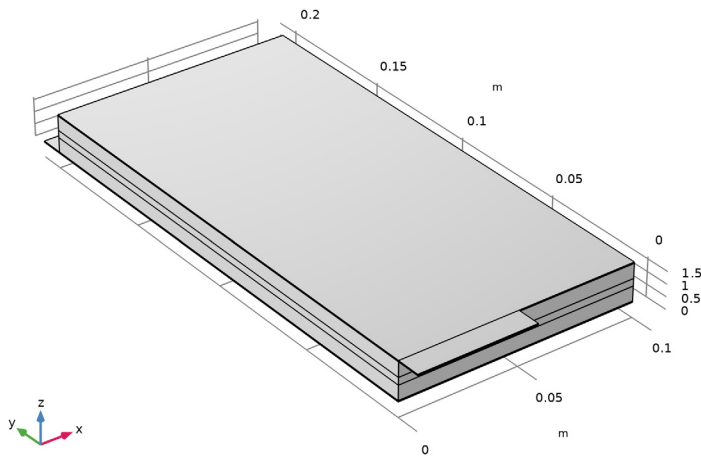

Figure 1: Model geometry, scaled 100 times in the z direction.

The Lithium-Ion Battery interface is used to set up the physics, using Material data from the Battery material library.

The Particle Intercalation subnodes to the Porous Electrode nodes model the solid lithium concentration in an additional particle dimension (extra dimension). The model hence defines a fully coupled “pseudo-4D” model.

The SOC and Initial Cell Charge Distribution node is used to set the initial cell state of charge to 20%.

An Electrode Ground boundary condition is used on the negative tab whereas an Electrode Current boundary condition defines the cell current exiting the cell on the positive tab.

A time-dependent solver is used to simulate the charging from a 20% to 90% cell state of charge at a rate of 4C. (A 1C rate corresponds to the charge or discharge current required to fully charge or discharge the battery in 1 h).

Results and Discussion

Figure 2 shows the voltage vs time during the 4C charging period.

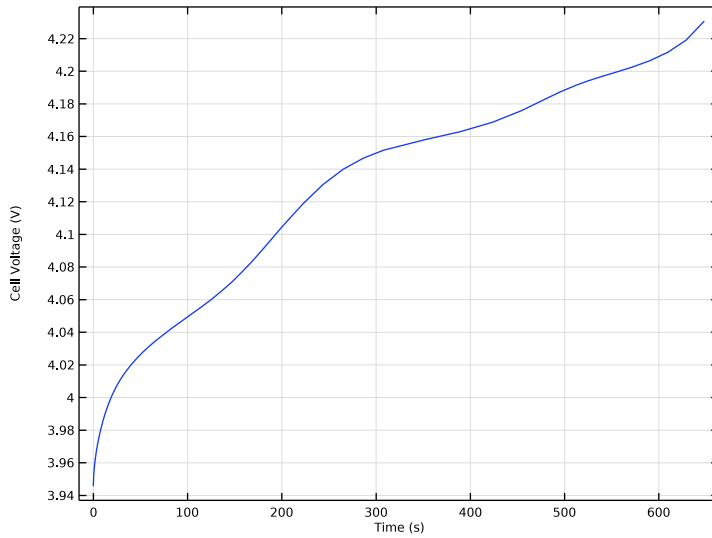

Figure 2: Cell voltage versus time.

Figure 3 and Figure 4 show the potential distribution in the negative and positive metal foils (current collector and tab), respectively, at the end of the 4C charge. The potential variation is about 5 mV in the negative current collector and 9 mV in the positive current collector at a 4C charge current.

For a 1C charge current the corresponding potential variation is below 2 mV (results not shown here).

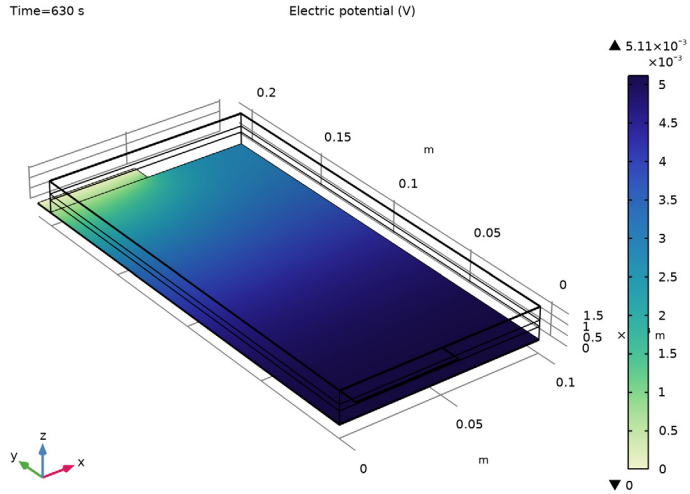

Figure 3: Potential distribution in the negative metal foil (current collector and tab) at the end of the 4C charge.

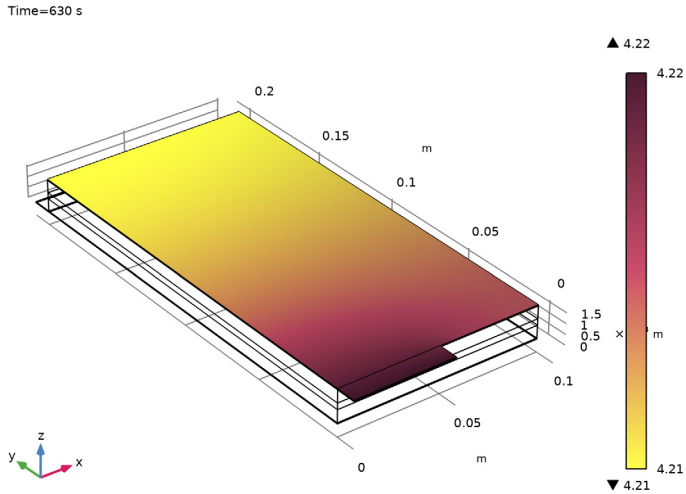

Figure 4: Potential distribution in the positive metal foil (current collector and tab) at the end of the 4C charge.

Figure 5 and Figure 6 show the current distribution for a cross section in the middle of the separator at the beginning and end of the 4C charge, respectively. This provides a measure of the electrode utilization for a given time. The current distribution varies about 6% in the separator plane over time. For 1C, the variation is generally smaller (results not shown here). Initially, the separator current density is higher close to the tabs whereas toward the end of the charge, the current density is higher in the central parts of the cell.

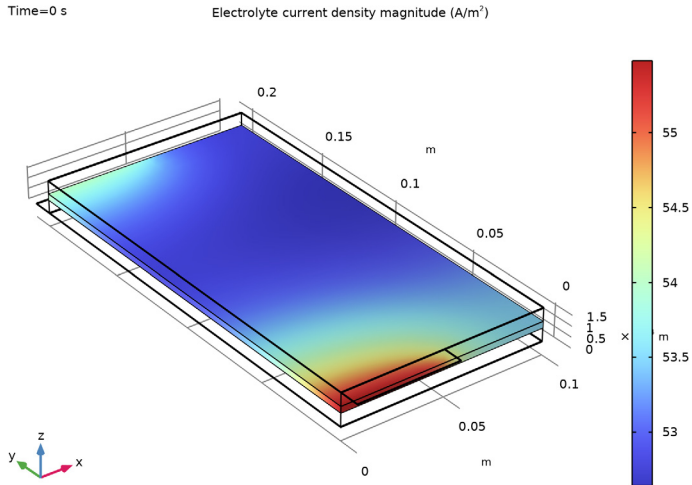

Figure 5: Current density magnitude in the middle of the separator at the beginning of the 4C charge.

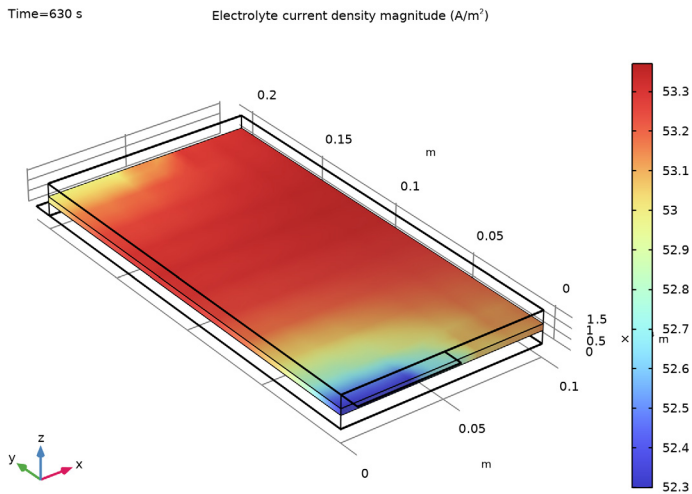

Figure 6: Current density magnitude in the middle of the separator at the end of the 4C charge.

To get a measure of the relative utilization over the whole charge period, General Projection operators are used to integrate the amount of lithium ($c_{s,avg}$) along the electrode depth (the z direction). Dividing the projected change of intercalated lithium by the average for the whole electrode gives a measure of the relative utilization (capacity throughput) U , as a function of the spatial independent variables x and y , at any time t .

$$U(x, y, t) = \frac{\epsilon_s F \int_0^{L_{elec}} (c_{s,avg}(x, y, z, t) - c_{s,avg}(x, y, z, 0)) dz}{\frac{1}{W_{cell} H_{cell}} \int_0^t I_{cell}(t) dt}$$

Figure 7 and Figure 8 show the relative utilization midway and at the end for the 4C charge for the positive electrode. The utilization varies between 99.5% and 102% for the 4C charge and changes little with time. The cycle-averaged utilization is lower than the instantaneous utilization shown in Figure 5 and Figure 6.

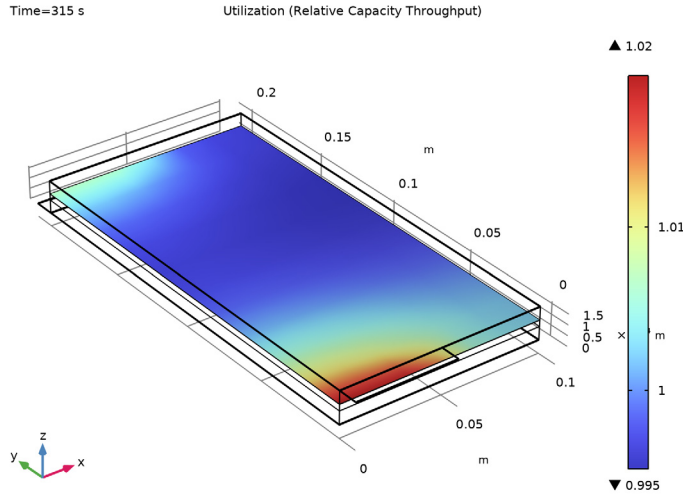

Figure 7: Relative electrode utilization midway in the 4C charge.

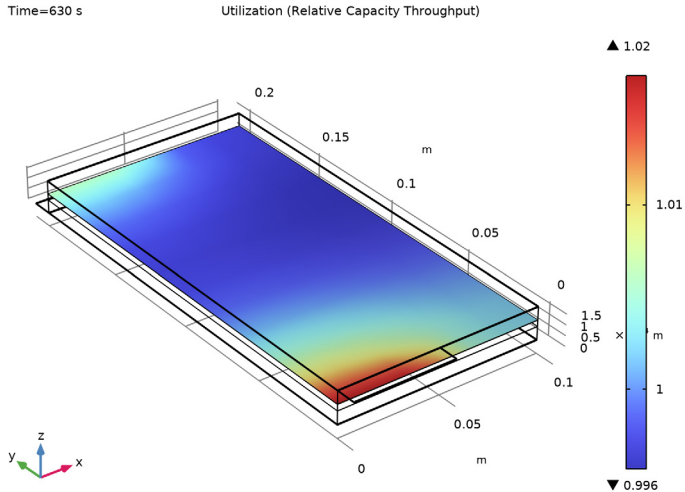

Figure 8: Relative electrode utilization at the end of the 4C charge.

The tutorial demonstrates that the local electrode utilization along the metal foil (current collector and tab) changes over the course of a charge cycle. For this configuration, charge of 4C results in a slightly nonuniform utilization.

Application Library path: Battery_Design_Module/Lithium-Ion_Batteries, _Performance/pouch_cell_utilization

Modeling Instructions

From the **File** menu, choose **New**.



NEW

In the **New** window, click  **Model Wizard**.

MODEL WIZARD

1 In the **Model Wizard** window, click  **3D**.

2 In the **Select Physics** tree, select **Electrochemistry** > **Batteries** > **Lithium-Ion Battery (liion)**.

- 3 Click **Add**.
- 4 Click  **Study**.
- 5 In the **Select Study** tree, select **Preset Studies for Selected Physics Interfaces > Time Dependent with Initialization**.
- 6 Click  **Done**.

GEOMETRY I

The model geometry is available as a parameterized geometry sequence in a separate MPH file. If you want to build it from scratch, follow the instructions in the section [Appendix — Geometry Modeling Instructions](#). Otherwise load it from file with the following steps.

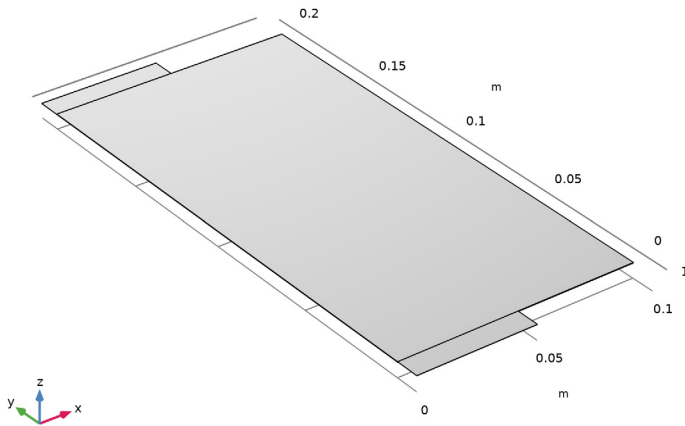

- 1 In the **Geometry** toolbar, click **Insert Sequence** and choose **Insert Sequence**.
- 2 Browse to the model's Application Libraries folder and double-click the file `pouch_cell_utilization_geom_sequence.mph`.
- 3 In the **Geometry** toolbar, click  **Build All**.
- 4 In the **Model Builder** window, under **Component I (comp1)** click **Geometry I**.



- 5 In the **Model Builder** window, collapse the **Geometry I** node.

Physics Parameters

Add some more parameters from a text file.

- 1 In the **Home** toolbar, click  **Parameters** and choose **Add > Parameters**.
- 2 In the **Settings** window for **Parameters**, type Physics Parameters in the **Label** text field.
- 3 Locate the **Parameters** section. Click  **Load from File**.
- 4 Browse to the model's Application Libraries folder and double-click the file `pouch_cell_utilization_physics_parameters.txt`.

MATERIALS

Most of the required material parameters are available in the material libraries. First add Copper and Aluminum for the current conductors.

ADD MATERIAL

- 1 In the **Materials** toolbar, click  **Add Material** to open the **Add Material** window.
- 2 Go to the **Add Material** window.
- 3 In the tree, select **Built-in > Aluminum** and **Built-in > Copper**.
- 4 Click the **Add to Component** button in the window toolbar.

ADD MATERIAL

Next add the material properties for the electrolyte and electrode materials.

- 1 Go to the **Add Material** window.
- 2 In the tree, select **Battery > Electrodes > Graphite, LixC6 MCMB (Negative, Li-ion Battery)** and **Battery > Electrodes > LMO, LiMn2O4 Spinel (Positive, Li-ion Battery)**.
- 3 Click the **Add to Component** button in the window toolbar.
- 4 In the tree, select **Battery > Electrolytes > LiPF6 in 3:7 EC:EMC (Liquid, Li-ion Battery)**.
- 5 Click the **Add to Component** button in the window toolbar.
- 6 In the **Materials** toolbar, click  **Add Material** to close the **Add Material** window.

MATERIALS

Aluminum (mat1)

Assign the materials to the corresponding battery domains.

- 1 In the **Model Builder** window, click **Aluminum (mat1)**.
- 2 In the **Settings** window for **Material**, locate the **Geometric Entity Selection** section.

3 From the **Selection** list, choose **Positive Current Collector and Tab**.

Copper (mat2)

1 In the **Model Builder** window, click **Copper (mat2)**.

2 In the **Settings** window for **Material**, locate the **Geometric Entity Selection** section.

3 From the **Selection** list, choose **Negative Current Collector and Tab**.

Graphite, LixC6 MCMB (Negative, Li-ion Battery) (mat3)

1 In the **Model Builder** window, click **Graphite, LixC6 MCMB (Negative, Li-ion Battery) (mat3)**.

2 In the **Settings** window for **Material**, locate the **Geometric Entity Selection** section.

3 From the **Selection** list, choose **Negative Electrode**.

LMO, LiMn2O4 Spinel (Positive, Li-ion Battery) (mat4)

1 In the **Model Builder** window, click **LMO, LiMn2O4 Spinel (Positive, Li-ion Battery) (mat4)**.

2 In the **Settings** window for **Material**, locate the **Geometric Entity Selection** section.

3 From the **Selection** list, choose **Positive Electrode**.

LiPF6 in 3:7 EC:EMC (Liquid, Li-ion Battery) (mat5)

1 In the **Model Builder** window, click **LiPF6 in 3:7 EC:EMC (Liquid, Li-ion Battery) (mat5)**.

2 In the **Settings** window for **Material**, locate the **Geometric Entity Selection** section.

3 From the **Selection** list, choose **Separator**.

LITHIUM-ION BATTERY (LIION)

Porous Electrode - Negative

The **Separator** node was added to the interface by default. Keep the default settings for the **Separator**, and proceed to add and set up the physics in the porous electrodes and current collectors.

1 In the **Physics** toolbar, click  **Domains** and choose **Porous Electrode**.

2 In the **Settings** window for **Porous Electrode**, type Porous Electrode - Negative in the **Label** text field.

3 Locate the **Domain Selection** section. From the **Selection** list, choose **Negative Electrode**.

4 Locate the **Electrolyte Properties** section. From the **Electrolyte material** list, choose **LiPF6 in 3:7 EC:EMC (Liquid, Li-ion Battery) (mat5)**.

5 Locate the **Electrode Properties** section. In the σ_s text field, type sigmas_neg.

6 Locate the **Porous Matrix Properties** section. In the ϵ_s text field, type eps_neg.

7 In the ϵ_1 text field, type 1-epss_neg.

Particle Intercalation I

Leave the settings of the **Species Settings** section as is for now. The initial species concentration setting will be made inactive later when we define the cell state of charge (SOC) on a different node.

- 1 In the **Model Builder** window, click **Particle Intercalation I**.
- 2 In the **Settings** window for **Particle Intercalation**, locate the **Particle Transport Properties** section.
- 3 In the r_p text field, type rp_neg.

Porous Electrode Reaction I

- 1 In the **Model Builder** window, click **Porous Electrode Reaction I**.
- 2 In the **Settings** window for **Porous Electrode Reaction**, locate the **Electrode Kinetics** section.
- 3 In the $i_{0,\text{ref}}(T)$ text field, type i0ref_neg.

Porous Electrode - Positive

- 1 In the **Physics** toolbar, click  **Domains** and choose **Porous Electrode**.
- 2 In the **Settings** window for **Porous Electrode**, type Porous Electrode - Positive in the **Label** text field.
- 3 Locate the **Domain Selection** section. From the **Selection** list, choose **Positive Electrode**.
- 4 Locate the **Electrolyte Properties** section. From the **Electrolyte material** list, choose **LiPF6 in 3:7 EC:EMC (Liquid, Li-ion Battery) (mat5)**.
- 5 Locate the **Electrode Properties** section. In the σ_s text field, type sigmas_pos.
- 6 Locate the **Porous Matrix Properties** section. In the ϵ_s text field, type epss_pos.
- 7 In the ϵ_1 text field, type 1-epss_pos.

Particle Intercalation I

- 1 In the **Model Builder** window, click **Particle Intercalation I**.
- 2 In the **Settings** window for **Particle Intercalation**, locate the **Particle Transport Properties** section.
- 3 In the r_p text field, type rp_pos.

Porous Electrode Reaction I

- 1 In the **Model Builder** window, click **Porous Electrode Reaction I**.

- 2 In the **Settings** window for **Porous Electrode Reaction**, locate the **Electrode Kinetics** section.
- 3 In the $i_{0,\text{ref}}(T)$ text field, type `i0ref_pos`.

Current Conductor 1

- 1 In the **Physics** toolbar, click  **Domains** and choose **Current Conductor**.
- 2 In the **Settings** window for **Current Conductor**, locate the **Domain Selection** section.
- 3 From the **Selection** list, choose **Metal Foil Domains**.

Electric Ground 1

- 1 In the **Physics** toolbar, click  **Boundaries** and choose **Electric Ground**.
- 2 In the **Settings** window for **Electric Ground**, locate the **Boundary Selection** section.
- 3 From the **Selection** list, choose **Negative Tab End**.

Enable the **Define cell state of charge (SOC) and initial charge inventory** on the interface top node. This will allow us to set the initial SOC of the battery cell.

- 4 In the **Model Builder** window, click **Lithium-Ion Battery (liion)**.
- 5 In the **Settings** window for **Lithium-Ion Battery**, locate the **Cell Settings** section.
- 6 Select the **Define cell state of charge (SOC) and initial charge inventory** checkbox.

SOC and Initial Charge Distribution 1

- 1 In the **Model Builder** window, click **SOC and Initial Charge Distribution 1**.
- 2 In the **Settings** window for **SOC and Initial Charge Distribution**, locate the **Initial Cell Charge Distribution** section.
- 3 In the SOC_0 text field, type `SOC_start`.

Negative Electrode Domain Selection 1

- 1 In the **Model Builder** window, click **Negative Electrode Domain Selection 1**.
- 2 In the **Settings** window for **Negative Electrode Domain Selection**, locate the **Domain Selection** section.
- 3 From the **Selection** list, choose **Negative Electrode**.

Positive Electrode Domain Selection 1

- 1 In the **Model Builder** window, click **Positive Electrode Domain Selection 1**.
- 2 In the **Settings** window for **Positive Electrode Domain Selection**, locate the **Domain Selection** section.
- 3 From the **Selection** list, choose **Positive Electrode**.

Electrode Current 1

- 1 In the **Physics** toolbar, click  **Boundaries** and choose **Electrode Current**.
- 2 In the **Settings** window for **Electrode Current**, locate the **Boundary Selection** section.
- 3 From the **Selection** list, choose **Positive Tab End**.
- 4 Locate the **Electrode Current** section. From the list, choose **C-rate multiple**.
- 5 In the C_{rate} text field, type C_rate .

MESH 1

Set up the mesh for the model. Use a mapped mesh on the top boundaries, and a swept mesh for remaining of the geometry.

Mapped 1

- 1 In the **Mesh** toolbar, click  **More Generators** and choose **Mapped**.
- 2 Select Boundary 20 only.
- 3 In the **Mesh** toolbar, click  **Build Mesh**.

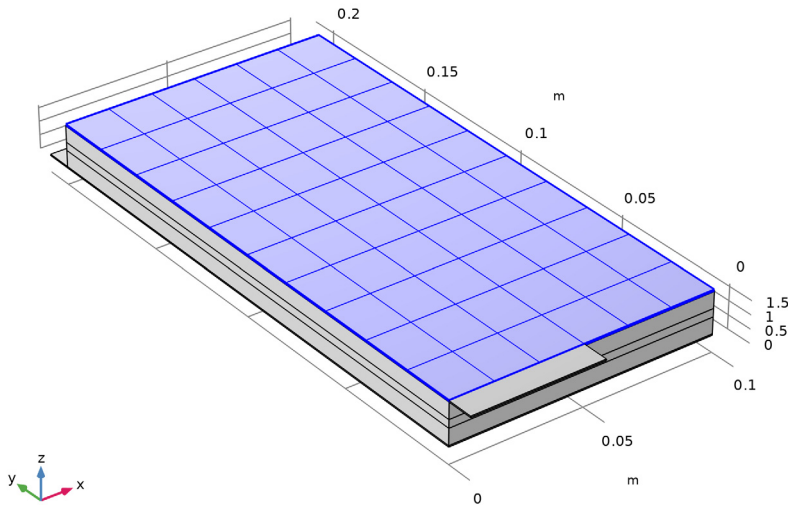

Swept 1

In the **Mesh** toolbar, click  **Swept**.

Distribution 1

1 Right-click **Swept 1** and choose **Distribution**.

By the use of **Distribution** nodes you can control the resolution in the z direction of the individual layers of the cell.

2 In the **Settings** window for **Distribution**, locate the **Domain Selection** section.

3 From the **Selection** list, choose **Negative Electrode**.

4 Locate the **Distribution** section. From the **Distribution type** list, choose **Predefined**.

5 In the **Number of elements** text field, type 15.

6 In the **Element ratio** text field, type 3.

Distribution 2

1 In the **Model Builder** window, right-click **Swept 1** and choose **Distribution**.

2 In the **Settings** window for **Distribution**, locate the **Domain Selection** section.

3 From the **Selection** list, choose **Separator**.

4 Locate the **Distribution** section. In the **Number of elements** text field, type 4.

Distribution 3

1 Right-click **Swept 1** and choose **Distribution**.

2 In the **Settings** window for **Distribution**, locate the **Domain Selection** section.

3 From the **Selection** list, choose **Positive Electrode**.

4 Locate the **Distribution** section. From the **Distribution type** list, choose **Predefined**.

5 In the **Number of elements** text field, type 15.

6 In the **Element ratio** text field, type 3.

7 Select the **Reverse direction** checkbox.

8 Click  **Build All**.

The finalized mesh should now look as follows.

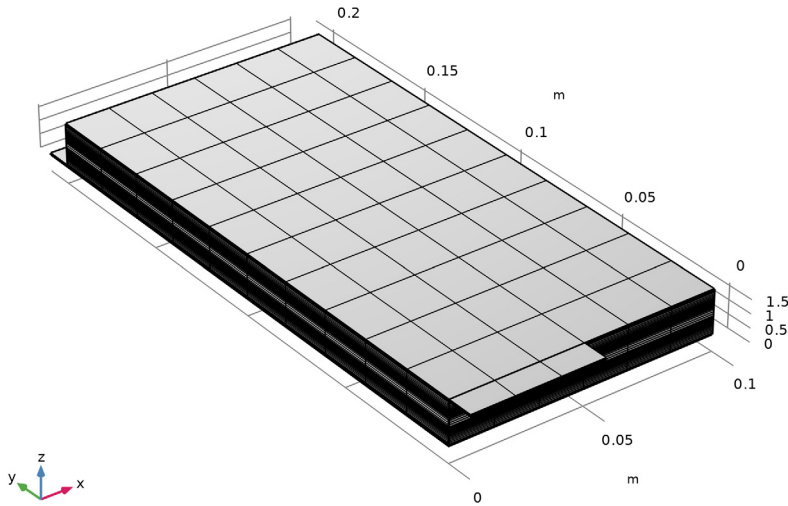

DEFINITIONS (COMPI)

Before solving, add also a probe for an automatically defined voltage variable created by the **Electrode Current** condition at the positive tab. Since the negative tab is grounded, this voltage corresponds to the cell voltage. The probe will store the cell voltage for every time step taken by the solver in a table, and a dynamically updated plot of the cell voltage will also be available while solving.

Cell Voltage Probe

- 1 In the **Definitions** toolbar, click  **Probes** and choose **Global Variable Probe**.
- 2 In the **Settings** window for **Global Variable Probe**, type Cell Voltage Probe in the **Label** text field.
- 3 Click **Replace Expression** in the upper-right corner of the **Expression** section. From the menu, choose **Component I (comp1) > Lithium-Ion Battery > liion.phis0_ecl - Electric potential on boundary - V**.
- 4 Locate the **Expression** section.
- 5 Select the **Description** checkbox. In the associated text field, type Cell Voltage.

STUDY 1

The physics is now fully defined and ready for solving. Change the output times based on the `sim_time` parameter to store the solution at the beginning of, half way into, and at the end of the charge as follows:

Step 2: Time Dependent

- 1 In the **Model Builder** window, under **Study 1** click **Step 2: Time Dependent**.
- 2 In the **Settings** window for **Time Dependent**, locate the **Study Settings** section.
- 3 In the **Output times** text field, type `0 sim_time/2 sim_time`.
- 4 In the **Study** toolbar, click  **Compute**.

The model takes approximately 2-3 minutes to solve.

RESULTS

A plot of the battery voltage versus time is created automatically by the probe you added earlier.

Cell Voltage Probe Plot

- 1 In the **Model Builder** window, under **Results** click **Probe Plot Group 1**.
- 2 In the **Settings** window for **ID Plot Group**, type `Cell Voltage Probe Plot` in the **Label** text field.
- 3 Locate the **Legend** section. Clear the **Show legends** checkbox.
- 4 In the **Cell Voltage Probe Plot** toolbar, click  **Plot**.

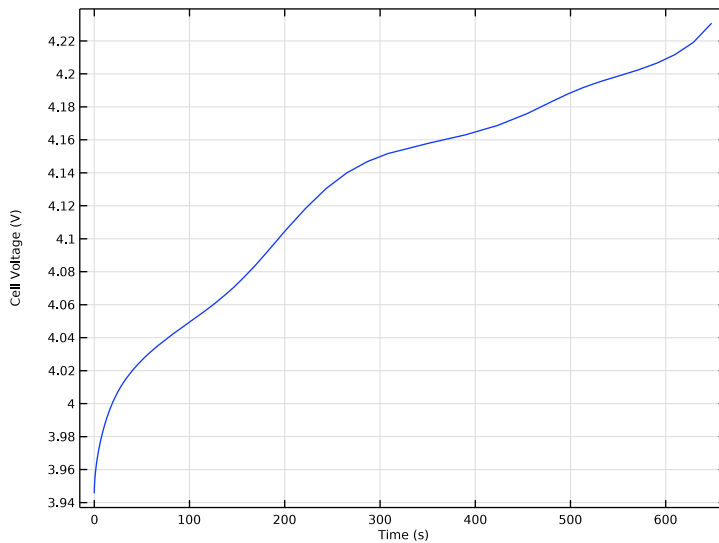

A plot of the potential in the electrodes and the current conductors is also generated by default. Alter the geometry selection to only show the metal foils.

Electrode Potential with Respect to Ground (liion)

- 1 In the **Model Builder** window, click **Electrode Potential with Respect to Ground (liion)**.
- 2 In the **Settings** window for **3D Plot Group**, click to expand the **Selection** section.
- 3 From the **Geometric entity level** list, choose **Domain**.
- 4 From the **Selection** list, choose **Metal Foil Domains**.

Surface 2

- 1 In the **Model Builder** window, expand the **Electrode Potential with Respect to Ground (liion)** node.
- 2 Right-click **Surface 2** and choose **Disable**.
- 3 In the **Electrode Potential with Respect to Ground (liion)** toolbar, click  **Plot**.

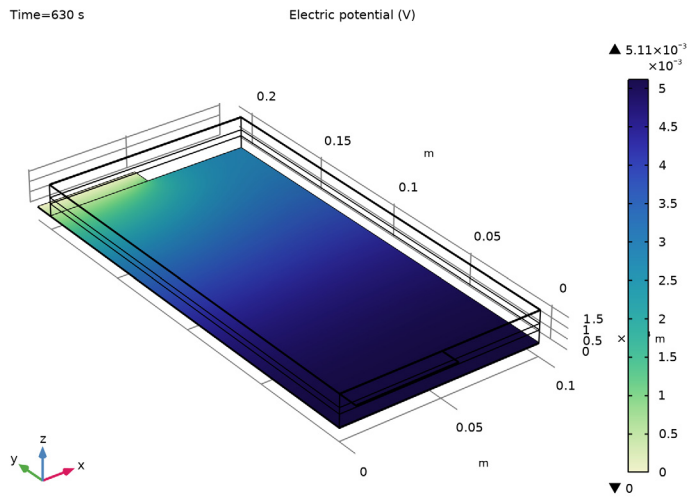

- 4 Right-click **Surface 2** and choose **Enable**.

Surface 1

- 1 In the **Model Builder** window, right-click **Surface 1** and choose **Disable**.

- 2 In the **Electrode Potential with Respect to Ground (liion)** toolbar, click  **Plot**.

Time=630 s

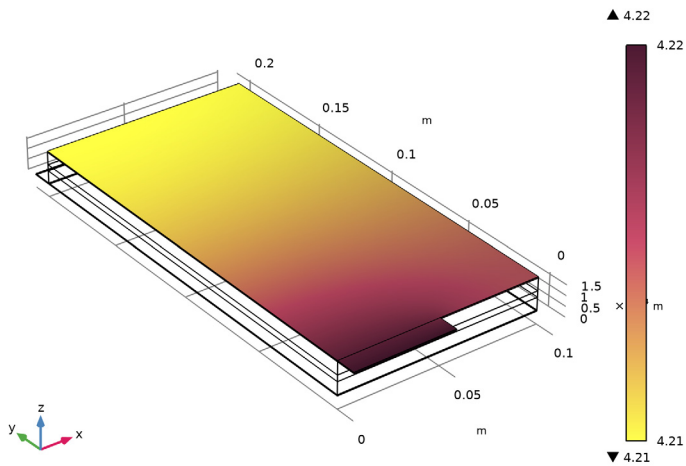

Separator Current Density Magnitude (liion)

Now review the plot of the current density magnitude in the separator at different times.

- 1 In the **Model Builder** window, under **Results** click **Separator Current Density Magnitude (liion)**.
- 2 In the **Settings** window for **3D Plot Group**, locate the **Data** section.
- 3 From the **Time (s)** list, choose **0**.

4 In the **Separator Current Density Magnitude (liion)** toolbar, click  **Plot**.

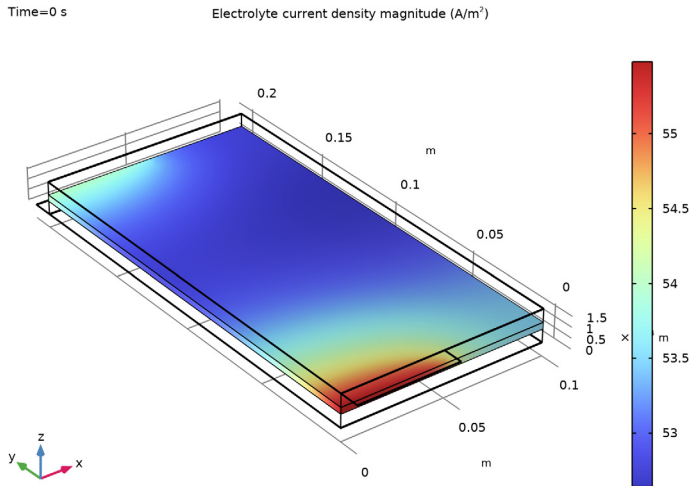

5 From the **Time (s)** list, choose **630**.

6 In the **Separator Current Density Magnitude (liion)** toolbar, click  **Plot**.

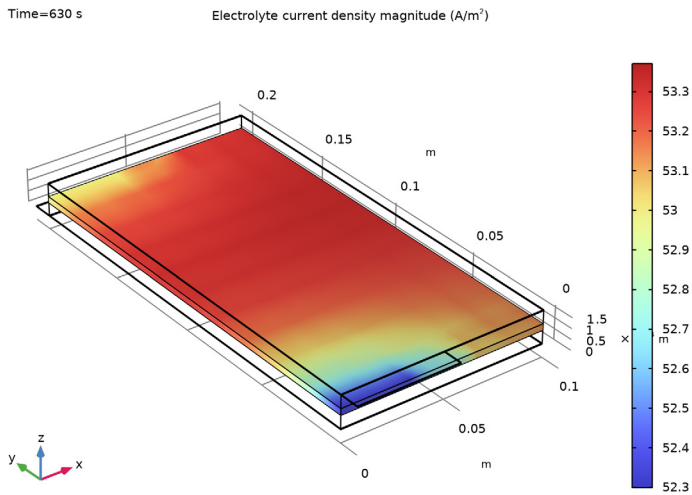

DEFINITIONS (COMPI)

As a final step we will evaluate the relative utilization of the electrodes during the whole charge.

First add two **General Projection** operators that will be used to integrate the amount of lithium along the electrode depth (the z direction).

General Projection - Negative

- 1 In the **Definitions** toolbar, click  **Nonlocal Couplings** and choose **General Projection**.
- 2 In the **Settings** window for **General Projection**, type General Projection - Negative in the **Label** text field.
- 3 In the **Operator name** text field, type genproj_neg.
- 4 Locate the **Source Selection** section. From the **Selection** list, choose **Negative Electrode**.

General Projection - Positive

- 1 Right-click **General Projection - Negative** and choose **Duplicate**.
- 2 In the **Settings** window for **General Projection**, type General Projection - Positive in the **Label** text field.
- 3 In the **Operator name** text field, type genproj_pos.
- 4 Locate the **Source Selection** section. From the **Selection** list, choose **Positive Electrode**.

Also add a variable for the applied current.

Variables I

- 1 In the **Model Builder** window, right-click **Definitions** and choose **Variables**.
- 2 In the **Settings** window for **Variables**, locate the **Variables** section.
- 3 In the table, enter the following settings:

Name	Expression	Unit	Description
I_app	liion.I_1C_cell*C_rate	A	Applied current

This variable expression makes use of an internal IC current variable (liion.I_1C_cell), based on the cyclable lithium capacity, which is computed automatically by the **SOC and Initial Charge Distribution** node.

STUDY I

In order to make the operators and the added variable available for postprocessing, you need to update the solution.

In the **Study** toolbar, click  **Update Solution**.

RESULTS



Utilization (Relative Capacity Throughput)

- 1 In the **Results** toolbar, click  **3D Plot Group**.
- 2 In the **Settings** window for **3D Plot Group**, type Utilization (Relative Capacity Throughput) in the **Label** text field.
- 3 Click to expand the **Title** section. From the **Title type** list, choose **Label**.
- 4 Locate the **Color Legend** section. Select the **Show maximum and minimum values** checkbox.

Surface 1

- 1 Right-click **Utilization (Relative Capacity Throughput)** and choose **Surface**.
- 2 In the **Settings** window for **Surface**, locate the **Expression** section.
- 3 In the **Expression** text field, type $\text{genproj_pos}(\text{at}(0, \text{liion.cs_average}) - \text{liion.cs_average}) * \text{epss_pos} * F_const * H_cell * W_cell / (I_app * t)$.

Selection 1

- 1 Right-click **Surface 1** and choose **Selection**.
- 2 Select Boundary 16 only.
- 3 In the **Utilization (Relative Capacity Throughput)** toolbar, click  **Plot**.
- 4 Click the  **Zoom Extents** button in the **Graphics** toolbar.

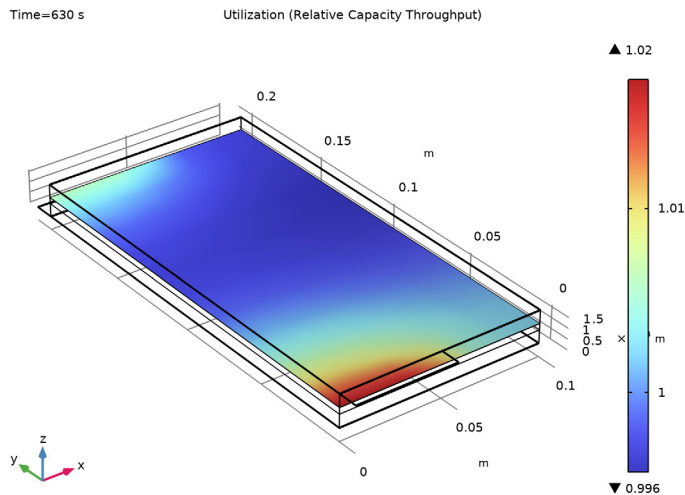

Utilization (Relative Capacity Throughput)

- 1 In the **Model Builder** window, under **Results** click **Utilization (Relative Capacity Throughput)**.
- 2 In the **Settings** window for **3D Plot Group**, locate the **Data** section.
- 3 From the **Time (s)** list, choose **315**.
- 4 In the **Utilization (Relative Capacity Throughput)** toolbar, click  **Plot**.

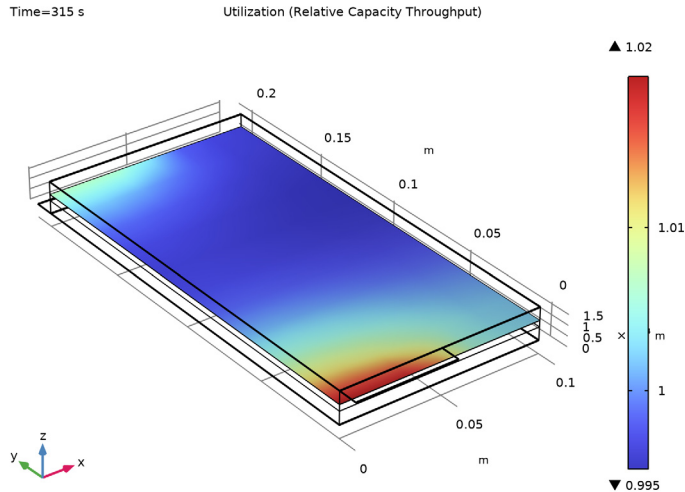

Appendix — Geometry Modeling Instructions

From the **File** menu, choose **New**.

NEW

In the **New** window, click  **Model Wizard**.

MODEL WIZARD

1 In the **Model Wizard** window, click  **3D**.

2 Click **Done**.

GLOBAL DEFINITIONS

Parameters 1

Import the parameter file.

- 1 In the **Model Builder** window, under **Global Definitions** click **Parameters I**.
- 2 In the **Settings** window for **Parameters**, locate the **Parameters** section.
- 3 Click  **Load from File**.
- 4 Browse to the model's Application Libraries folder and double-click the file `pouch_cell_utilization_geometry_parameters.txt`.

GEOMETRY I

Set up the model geometry using the following steps.

Work Plane 1 (wp1)

In the **Geometry** toolbar, click  **Work Plane**.

Work Plane 1 (wp1) > Plane Geometry

In the **Model Builder** window, click **Plane Geometry**.

Work Plane 1 (wp1) > Rectangle 1 (r1)

- 1 In the **Work Plane** toolbar, click  **Rectangle**.
- 2 In the **Settings** window for **Rectangle**, locate the **Size and Shape** section.
- 3 In the **Width** text field, type `W_cell`.
- 4 In the **Height** text field, type `H_cell`.



Extrude 1 (ext1)

- 1 In the **Model Builder** window, right-click **Geometry I** and choose **Extrude**.
- 2 In the **Settings** window for **Extrude**, locate the **Distances** section.
- 3 In the table, enter the following settings:



Distances (m)
<code>L_neg_cc/2</code>
<code>L_neg_cc/2+L_neg</code>
<code>L_neg_cc/2+L_neg+L_sep</code>
<code>L_neg_cc/2+L_neg+L_sep+L_pos</code>
<code>L_neg_cc/2+L_neg+L_sep+L_pos+L_pos_cc/2</code>

Block 1 (blk1)

- 1 In the **Geometry** toolbar, click  **Block**.
- 2 In the **Settings** window for **Block**, locate the **Size and Shape** section.
- 3 In the **Width** text field, type `W_tab`.
- 4 In the **Depth** text field, type `H_tab`.

- 5 In the **Height** text field, type $L_{neg_cc}/2$.
- 6 Locate the **Position** section. In the **y** text field, type H_{cell} .
- 7 Click  **Build Selected**.
- 8 Click the  **Zoom Extents** button in the **Graphics** toolbar.

Block 2 (blk2)

- 1 In the **Geometry** toolbar, click  **Block**.
- 2 In the **Settings** window for **Block**, locate the **Size and Shape** section.
- 3 In the **Width** text field, type W_{tab} .
- 4 In the **Depth** text field, type H_{tab} .
- 5 In the **Height** text field, type $L_{neg_cc}/2$.
- 6 Locate the **Position** section. In the **y** text field, type $-H_{tab}$.
- 7 In the **z** text field, type $L_{neg_cc}/2+L_{neg}+L_{sep}+L_{pos}$.
- 8 Click  **Build Selected**.

Form Union (fin)

In the **Geometry** toolbar, click  **Build All**.

DEFINITIONS

Scale the geometry in the z direction to make it easier to see the different layers in the model geometry.

View 1

In the **Model Builder** window, expand the **Component 1 (comp1) > Definitions** node.

Camera

- 1 In the **Model Builder** window, expand the **View 1** node, then click **Camera**.
- 2 In the **Settings** window for **Camera**, locate the **Camera** section.
- 3 From the **View scale** list, choose **Manual**.
- 4 In the **z scale** text field, type 100.
- 5 Click  **Update**.

- 6 Click the  **Zoom Extents** button in the **Graphics** toolbar.
The finalized geometry should now look like as follows.

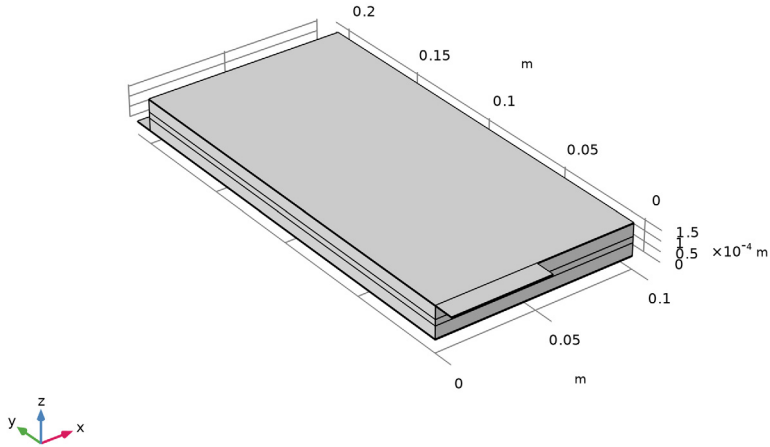

GEOMETRY I

Create named selections of the different battery domains for ease of selection later in the model.

In the **Geometry** toolbar, click  **Build All**.

Positive Tab

- 1 In the **Geometry** toolbar, click  **Selections** and choose **Explicit Selection**.
- 2 In the **Settings** window for **Explicit Selection**, type Positive Tab in the **Label** text field.
- 3 On the object **fin**, select Domain 1 only.

Positive Current Collector

- 1 In the **Geometry** toolbar, click  **Selections** and choose **Explicit Selection**.
- 2 In the **Settings** window for **Explicit Selection**, type Positive Current Collector in the **Label** text field.
- 3 On the object **fin**, select Domain 6 only.

Positive Electrode

- 1 In the **Geometry** toolbar, click  **Selections** and choose **Explicit Selection**.
- 2 In the **Settings** window for **Explicit Selection**, type Positive Electrode in the **Label** text field.
- 3 On the object **fin**, select Domain 5 only.

Negative Tab

- 1 In the **Geometry** toolbar, click  **Selections** and choose **Explicit Selection**.
- 2 In the **Settings** window for **Explicit Selection**, type Negative Tab in the **Label** text field.
- 3 On the object **fin**, select Domain 7 only.

Negative Current Collector

- 1 In the **Geometry** toolbar, click  **Selections** and choose **Explicit Selection**.
- 2 In the **Settings** window for **Explicit Selection**, type Negative Current Collector in the **Label** text field.
- 3 On the object **fin**, select Domain 2 only.



Negative Electrode

- 1 In the **Geometry** toolbar, click  **Selections** and choose **Explicit Selection**.
- 2 In the **Settings** window for **Explicit Selection**, type Negative Electrode in the **Label** text field.
- 3 On the object **fin**, select Domain 3 only.



Separator

- 1 In the **Geometry** toolbar, click  **Selections** and choose **Explicit Selection**.
- 2 In the **Settings** window for **Explicit Selection**, type Separator in the **Label** text field.
- 3 On the object **fin**, select Domain 4 only.



Negative Tab End

- 1 In the **Geometry** toolbar, click  **Selections** and choose **Explicit Selection**.
- 2 In the **Settings** window for **Explicit Selection**, type Negative Tab End in the **Label** text field.
- 3 Locate the **Entities to Select** section. From the **Geometric entity level** list, choose **Boundary**.
- 4 Click the  **Paste Selection** button for **Entities to select**.
- 5 In the **Paste Selection** dialog, type 29 in the **Selection** text field.
- 6 Click **OK**.



Positive Tab End

- 1 In the **Geometry** toolbar, click  **Selections** and choose **Explicit Selection**.
- 2 In the **Settings** window for **Explicit Selection**, type Positive Tab End in the **Label** text field.
- 3 Locate the **Entities to Select** section. From the **Geometric entity level** list, choose **Boundary**.
- 4 Click the  **Paste Selection** button for **Entities to select**.
- 5 In the **Paste Selection** dialog, type 2 in the **Selection** text field.
- 6 Click **OK**.



Negative Current Collector and Tab

- 1 In the **Geometry** toolbar, click  **Selections** and choose **Union Selection**.
- 2 In the **Settings** window for **Union Selection**, type Negative Current Collector and Tab in the **Label** text field.
- 3 Locate the **Input Entities** section. Click  **Add**.
- 4 In the **Add** dialog, in the **Selections to add** list, choose **Negative Tab** and **Negative Current Collector**.
- 5 Click **OK**.

Positive Current Collector and Tab

- 1 In the **Geometry** toolbar, click  **Selections** and choose **Union Selection**.
- 2 In the **Settings** window for **Union Selection**, type Positive Current Collector and Tab in the **Label** text field.
- 3 Locate the **Input Entities** section. Click  **Add**.
- 4 In the **Add** dialog, in the **Selections to add** list, choose **Positive Tab** and **Positive Current Collector**.
- 5 Click **OK**.

Metal Foil Domains

- 1 In the **Geometry** toolbar, click  **Selections** and choose **Union Selection**.
- 2 In the **Settings** window for **Union Selection**, type Metal Foil Domains in the **Label** text field.
- 3 Locate the **Input Entities** section. Click  **Add**.
- 4 In the **Add** dialog, in the **Selections to add** list, choose **Negative Current Collector and Tab** and **Positive Current Collector and Tab**.
- 5 Click **OK**.

