



Model created in COMSOL Multiphysics 6.4

# Jelly Roll Using a Flattened Geometry

## *Introduction*

---

This example replicates the results of the [Jelly Roll](#) tutorial model using a flattened representation of the wound spiral-based geometry. See that model entry for details on the background, original geometry, materials, and the general physics setup.

The spiraling aspects of the true jelly roll geometry are a bit cumbersome to work with, in regards to, for instance, visualizing simulation results in the layers, or introducing additional geometry objects like multiple tabs in the interior of the jelly roll.

In this tutorial we perform the model calculations on a flattened (not rolled) version of the jelly roll. In the flattened geometry representation, special boundary conditions are needed in order to couple geometrically detached boundaries together mathematically.

The flattened geometry has the advantage of requiring less mesh elements since the local curvature of the roll does not need to be resolved but with the disadvantage that the transport equations on the flattened geometry neglect the effect of the local curvature of the layers. However, as seen when comparing the temperature and potential profiles, the flattened geometry accurately reproduces the original jelly roll tutorial, indicating that we can perform this flattening transformation with only a limited effect on the results.

## *Model Definition*

---

Like the original jelly roll model, this tutorial uses a pseudostationary approach, only accounting for the ohmic voltage losses in the electronic conductors and the electrolyte and the activation overpotentials due to the charge transfer reactions in the electrodes. The current distribution is modeled using a **Secondary Current Distribution** interface.

In the current distribution model, a ground condition is used at the negative terminal, where as a IC total current condition is applied at the positive terminal.

The temperature distribution in the jelly roll is modeled using a **Heat Transfer** interface, applying the resulting heat sources from the current distribution model using an **Electrochemical Heating** multiphysics node. A convective cooling boundary condition on the outer area of the jelly roll is used, prescribing a cooling heat flux proportional to the surface temperature and the exterior temperature (25°C).

[Figure 1](#) shows the model geometry. Each layer in the roll, as well as the tabs, are drawn as rectangular blocks. The layers are 60 mm high.

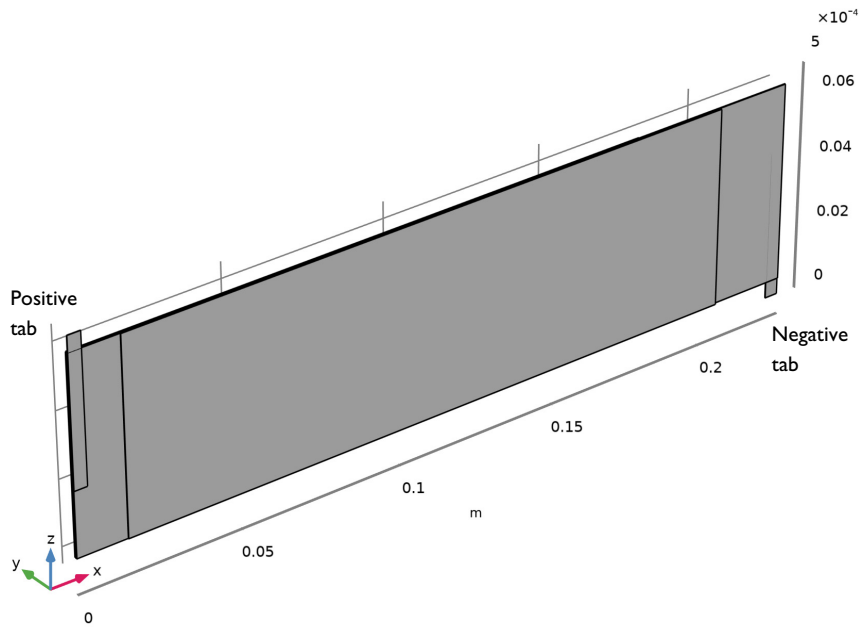

*Figure 1: Model geometry.*

In the original spiral geometry all layers in the roll differ in length. This is due to the winding of the spiral in combination with a different starting radius at the center of the spiral for each layer. In the flattened geometry representation we will approximate this effect by grouping the layers into two parts, centered around the positive and negative current collectors, with the length of the layers in each part being based on the corresponding current collector (approximately 22.8 and 20.6 cm, respectively). Each separator is split into two domains at mid thickness, with one domain placed in the negative part, and one domain placed in the positive part. In order to be able to use mapped meshes with the same amount of elements at the mid-separator boundaries (see below about linear extrusion operators), the geometry is finalized as an assembly, with assembly pair boundaries located between the separators and the electrodes.

[Figure 2](#) shows the meshed model geometry as seen from above, scaled 100 times in the through-plane direction. An offset distance has been added between the negative and positive parts for easier visualization and selection handling in the user interface. The mesh is swept in the through-plane direction.

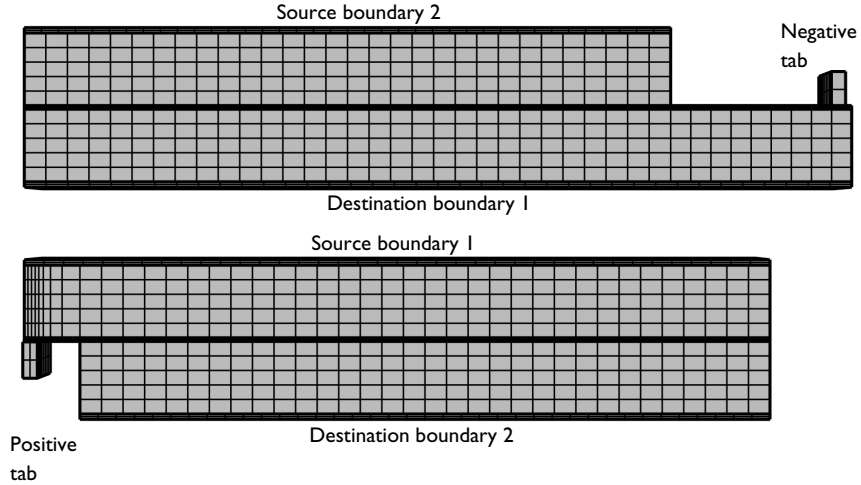

*Figure 2: Model geometry, seen from above, scaled 100 times in the through-plane direction. The location of the mid-separator source and destination boundaries, used for coupling the negative and positive parts together, are indicated in the figure.*

In order to couple the temperature and electrolyte potentials, and the corresponding local fluxes of heat and current, along the mid-separator boundaries between the two parts, linear extrusion operators are added. The linear extrusion operators maps each point on a source boundary to its corresponding location at a destination boundary.

The linear extrusion operators are then used to define pointwise constraints on the destination boundaries, prescribing continuity in temperature and potential according to  $T = \text{linext}(T)$  and  $\phi_l = \text{linext}(\phi_l)$ . This condition is accomplished internally by balancing the local fluxes of heat and current, scaled by the relative differences in area of the source and destination boundaries. Mapped meshes are used on the source and destination boundaries, ensuring the same amount of mesh elements, with a one-to-one mapping of the mesh node points. This avoids spurious oscillations in the solution.

## Results and Discussion

Figure 3 and Figure 4 show the simulated potential distribution in the negative and positive current collectors, respectively, for the jelly roll when subjected to a 1C discharge.

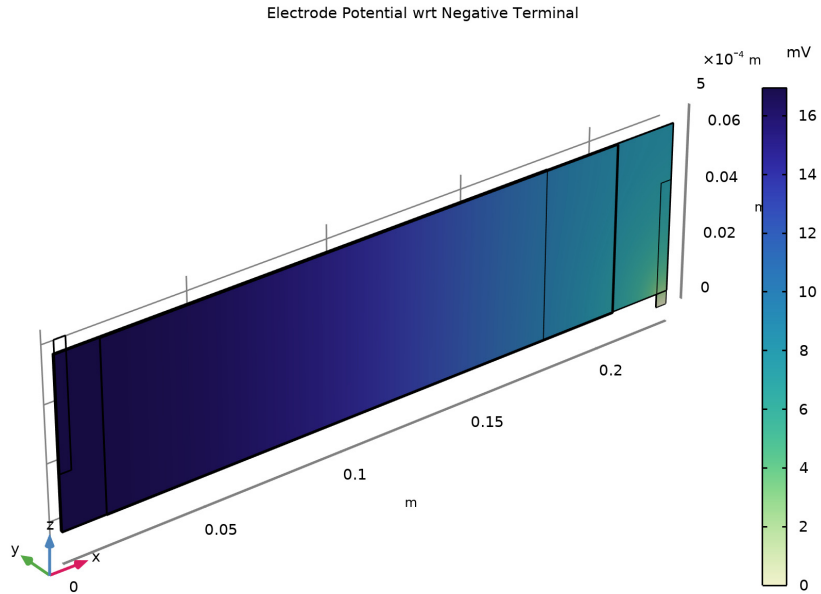
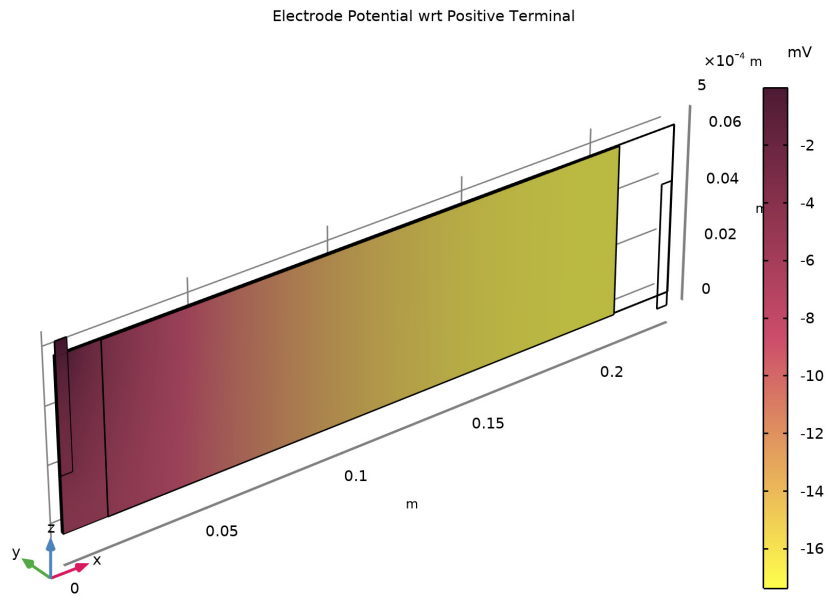
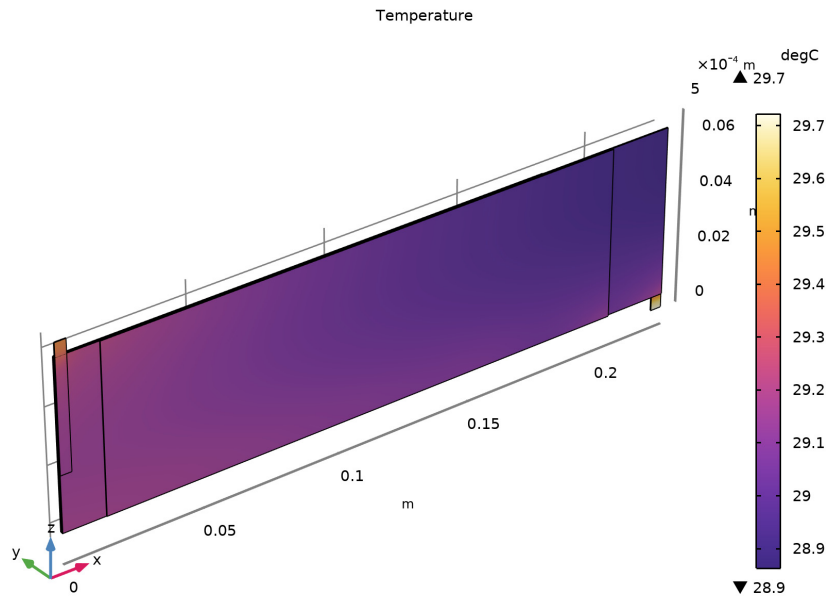

Figure 3: Potential in the negative current collector and tab.



*Figure 4: Potential in the positive current collector and tab.*

Figure 5 shows the corresponding temperature distribution. In all, Figure 3 to Figure 5 reproduce the results of the original [Jelly Roll](#) tutorial very closely.



*Figure 5: Temperature distribution.*

The flattened geometry now allows for easy visualization of the cross-separator current densities as shown in [Figure 6](#) and [Figure 7](#).

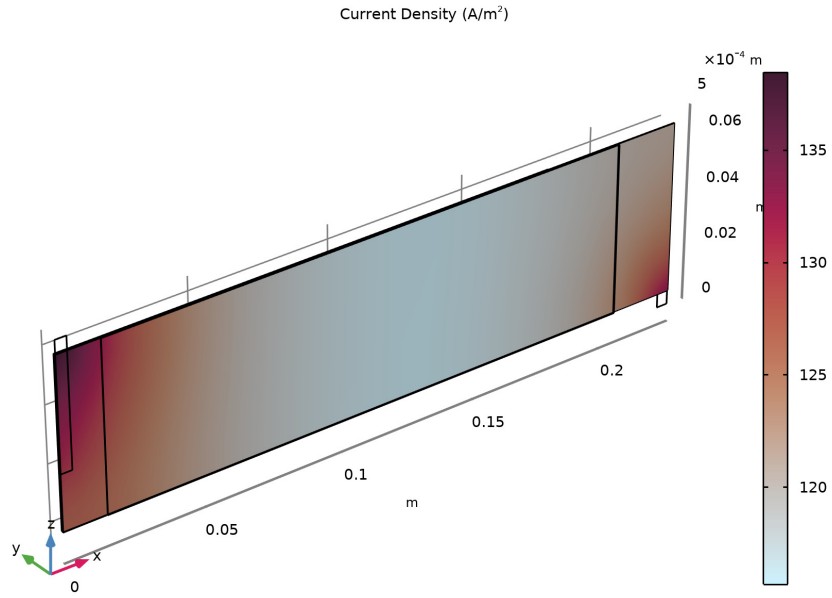
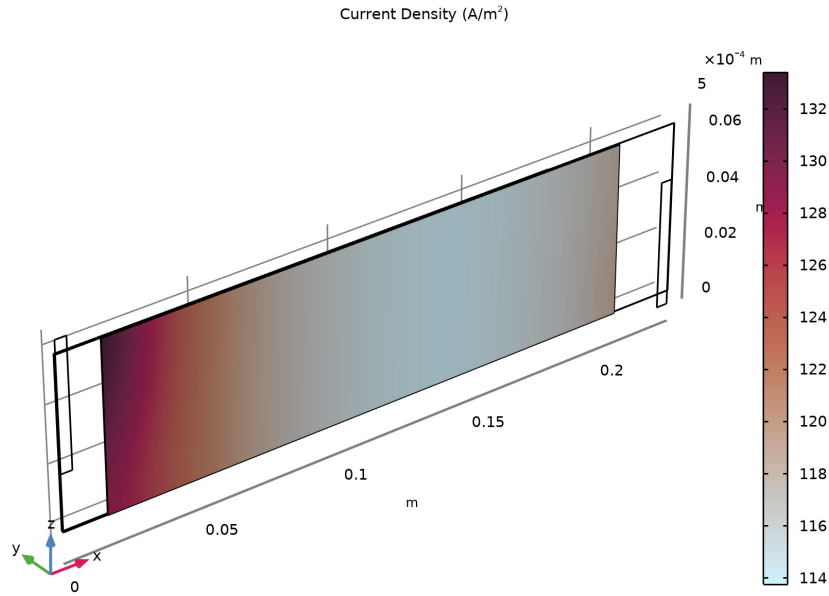

Figure 6: Current distribution in the through-plane direction of one of the separators.



*Figure 7: Current distribution in the through-plane direction of the other separator.*

Current distribution plots like this are valuable input to a battery designer, since they indicate significantly higher current densities in the area close to the tabs. We should remember that our model is pseudostationary, meaning that it is not accounting for redistribution of lithium in the cell. If the cell were to run for longer times, the current distribution plots shown above would eventually even out to a more homogeneous profile, as the distribution would accommodate for changes in local equilibrium potentials. However, a battery being cycled for short times around fixed state of charge would be exposed to more electrochemical wear in the areas close to the tabs, possibly resulting in accelerated aging.

---

**Application Library path:** Battery\_Design\_Module/Thermal\_Management/  
jelly\_roll\_flattened



---

From the **File** menu, choose **New**.

#### **NEW**

In the **New** window, click  **Model Wizard**.

#### **MODEL WIZARD**

- 1 In the **Model Wizard** window, click  **3D**.
- 2 In the **Select Physics** tree, select **Electrochemistry** > **Primary and Secondary Current Distribution** > **Secondary Current Distribution (cd)**.
- 3 Click **Add**.
- 4 In the **Select Physics** tree, select **Heat Transfer** > **Heat Transfer in Solids (ht)**.
- 5 Click **Add**.
- 6 In the **Select Physics** tree, select **Heat Transfer**.
- 7 Click  **Study**.
- 8 In the **Select Study** tree, select **General Studies** > **Stationary**.
- 9 Click  **Done**.

#### **GEOMETRY I**

Insert a geometry sequence from a file.

- 1 In the **Geometry** toolbar, click **Insert Sequence** and choose **Insert Sequence**.
- 2 Browse to the model's Application Libraries folder and double-click the file `jelly_roll_flattened_geom_sequence.mph`.
- 3 In the **Geometry** toolbar, click  **Build All**.

4 In the **Model Builder** window, under **Component 1 (comp1)** click **Geometry 1**.

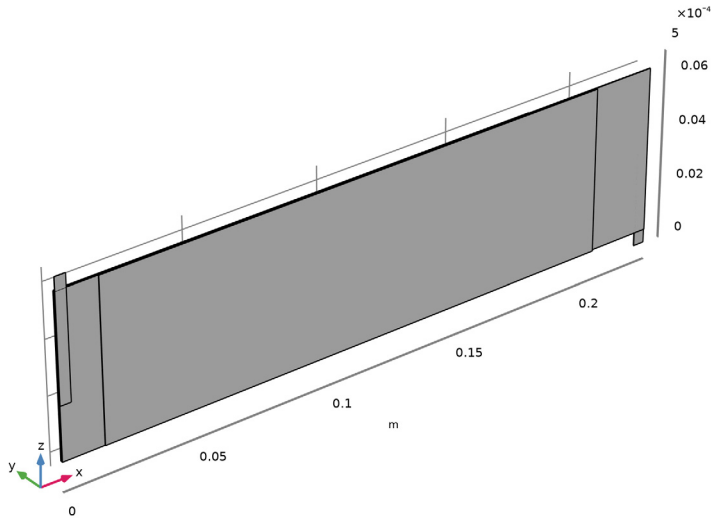

Disable the analysis of the geometry as the remaining small geometric details are needed.

5 In the **Model Builder** window, click **Geometry 1**.

6 In the **Settings** window for **Geometry**, locate the **Cleanup** section.

7 Clear the **Automatic detection of small details** checkbox.

8 In the **Geometry** toolbar, click  **Build All**.

## DEFINITIONS

Add a view with scaling in the *y* direction to facilitate selections in the **Graphics** window while setting up the physics and meshing.

### *View 5*

In the **Model Builder** window, under **Component 1 (comp1)** right-click **Definitions** and choose **View**.

### *Camera*

1 In the **Model Builder** window, expand the **View 5** node, then click **Camera**.

2 In the **Settings** window for **Camera**, locate the **Camera** section.

3 From the **View scale** list, choose **Manual**.

4 In the **y scale** text field, type 100.

5 Click  **Update**.

6 Click the  **Go to XY View** button in the **Graphics** toolbar.

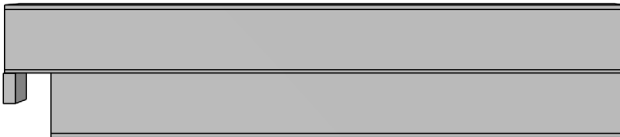
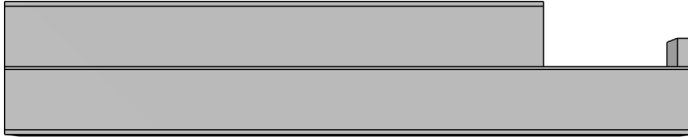

7 Click the  **Go to Default View** button in the **Graphics** toolbar.

## **GEOMETRY I**



In the **Model Builder** window, collapse the **Component I (comp1) > Geometry I** node.

## **GLOBAL DEFINITIONS**



### *Geometry Parameters*

- 1 In the **Model Builder** window, under **Global Definitions** click **Parameters I**.
- 2 In the **Settings** window for **Parameters**, type *Geometry Parameters* in the **Label** text field.

### *Physics Parameters*

- 1 In the **Home** toolbar, click  **Parameters** and choose **Add > Parameters**.
- 2 In the **Settings** window for **Parameters**, type *Physics Parameters* in the **Label** text field.
- 3 Locate the **Parameters** section. Click  **Load from File**.
- 4 Browse to the model's Application Libraries folder and double-click the file `jelly_roll_flattened_parameters.txt`.

## ADD MATERIAL

- 1 In the **Materials** toolbar, click  **Add Material** to open the **Add Material** window.
- 2 Go to the **Add Material** window.
- 3 In the tree, select **Built-in > Aluminum**.
- 4 Right-click and choose **Add to Component 1 (comp1)**.
- 5 In the tree, select **Built-in > Copper**.
- 6 Right-click and choose **Add to Component 1 (comp1)**.
- 7 In the tree, select **Battery > Electrodes > Graphite, LixC6 MCMB (Negative, Li-ion Battery)**.
- 8 Right-click and choose **Add to Component 1 (comp1)**.
- 9 In the tree, select **Battery > Electrodes > NMC 111, LiNi0.33Mn0.33Co0.33O2 (Positive, Li-ion Battery)**.
- 10 Right-click and choose **Add to Component 1 (comp1)**.
- 11 In the tree, select **Battery > Electrolytes > LiPF6 in 3:7 EC:EMC (Liquid, Li-ion Battery)**.
- 12 Right-click and choose **Add to Component 1 (comp1)**.
- 13 In the **Materials** toolbar, click  **Add Material** to close the **Add Material** window.

## MATERIALS

### *Aluminum (mat1)*

- 1 In the **Settings** window for **Material**, locate the **Geometric Entity Selection** section.
- 2 From the **Selection** list, choose **Positive CC and Tab**.

### *Copper (mat2)*

- 1 In the **Model Builder** window, click **Copper (mat2)**.
- 2 In the **Settings** window for **Material**, locate the **Geometric Entity Selection** section.
- 3 From the **Selection** list, choose **Negative CC**.

### *Graphite, LixC6 MCMB (Negative, Li-ion Battery) (mat3)*

- 1 In the **Model Builder** window, click **Graphite, LixC6 MCMB (Negative, Li-ion Battery) (mat3)**.
- 2 In the **Settings** window for **Material**, locate the **Geometric Entity Selection** section.
- 3 From the **Selection** list, choose **Negative Electrodes**.

### *NMC 111, LiNi0.33Mn0.33Co0.33O2 (Positive, Li-ion Battery) (mat4)*

- 1 In the **Model Builder** window, click **NMC 111, LiNi0.33Mn0.33Co0.33O2 (Positive, Li-ion Battery) (mat4)**.

- 2 In the **Settings** window for **Material**, locate the **Geometric Entity Selection** section.
- 3 From the **Selection** list, choose **Positive Electrodes**.

*LiPF6 in 3:7 EC:EMC (Liquid, Li-ion Battery) (mat5)*

- 1 In the **Model Builder** window, click **LiPF6 in 3:7 EC:EMC (Liquid, Li-ion Battery) (mat5)**.
- 2 In the **Settings** window for **Material**, locate the **Geometric Entity Selection** section.
- 3 From the **Selection** list, choose **Separators**.

*Nickel*

The negative tab consists of nickel metal, which is not available in the material library. Add a blank material node for nickel for now. We will add the required parameters later.

- 1 In the **Model Builder** window, right-click **Materials** and choose **Blank Material**.
- 2 In the **Settings** window for **Material**, type `Nickel` in the **Label** text field.
- 3 Locate the **Geometric Entity Selection** section. From the **Selection** list, choose **Negative Tab**.

## SECONDARY CURRENT DISTRIBUTION (CD)

*Electrolyte 1*

Now start defining the current distribution model.

- 1 In the **Model Builder** window, under **Component 1 (comp1) > Secondary Current Distribution (cd)** click **Electrolyte 1**.
- 2 In the **Settings** window for **Electrolyte**, locate the **Electrolyte** section.
- 3 From the  $\sigma_1$  list, choose **User defined**. In the associated text field, type `sigma1_eff`.

*Current Conductor 1*

- 1 In the **Physics** toolbar, click  **Domains** and choose **Current Conductor**.
- 2 In the **Settings** window for **Current Conductor**, locate the **Domain Selection** section.
- 3 From the **Selection** list, choose **CCs and Tabs**.

The electrode node defines electronic conduction in the metal phase domains. The conductivity is taken from the Material nodes by default, so no additional settings are needed here.

### *Porous Electrode I*

1 In the **Physics** toolbar, click  **Domains** and choose **Porous Electrode**.

The porous electrode node defines the electronic and ionic conduction in the electrode and electrolyte phases, respectively. Since we use the same settings in the positive and negative electrode materials in this tutorial, it suffices to use one single node.

2 In the **Settings** window for **Porous Electrode**, locate the **Domain Selection** section.

3 From the **Selection** list, choose **Electrodes**.

4 Locate the **Electrolyte Current Conduction** section. From the  $\sigma_l$  list, choose **User defined**. In the associated text field, type `sigma1_eff`.

5 From the **Effective conductivity correction** list, choose **No correction**.

6 Locate the **Electrode Current Conduction** section. From the  $\sigma_s$  list, choose **User defined**. In the associated text field, type `sigmas_eff`.

7 From the **Effective conductivity correction** list, choose **No correction**.

### *Porous Electrode Reaction I*

In this tutorial we are only interested in the voltage losses, not the resulting cell voltage. Therefore we use the default value of 0 V for the equilibrium potential in both electrodes. The resulting potential at the positive current terminal will thereby equal the total polarization of the cell.

1 In the **Model Builder** window, click **Porous Electrode Reaction I**.

2 In the **Settings** window for **Porous Electrode Reaction**, locate the **Electrode Kinetics** section.

3 From the **Kinetics expression type** list, choose **Butler–Volmer**.

4 In the  $i_0$  text field, type `i0`.

5 Locate the **Active Specific Surface Area** section. In the  $a_v$  text field, type `Av`.

### *Electric Ground I*

1 In the **Physics** toolbar, click  **Boundaries** and choose **Electric Ground**.

2 In the **Settings** window for **Electric Ground**, locate the **Boundary Selection** section.

3 From the **Selection** list, choose **Negative Current Terminal**.

### *Electrode Current I*

1 In the **Physics** toolbar, click  **Boundaries** and choose **Electrode Current**.

2 In the **Settings** window for **Electrode Current**, locate the **Boundary Selection** section.

3 From the **Selection** list, choose **Positive Current Terminal**.

4 Locate the **Electrode Current** section. In the  $I_{s,total}$  text field, type `I_1C`.

## HEAT TRANSFER IN SOLIDS (HT)

- 1 In the **Model Builder** window, under **Component 1 (comp1)** click **Heat Transfer in Solids (ht)**.
- 2 In the **Settings** window for **Heat Transfer in Solids**, click to expand the **Discretization** section.
- 3 From the **Temperature** list, choose **Linear**.

### *Solid 1*

- 1 In the **Model Builder** window, under **Component 1 (comp1)** > **Heat Transfer in Solids (ht)** click **Solid 1**.
- 2 In the **Settings** window for **Solid**, locate the **Thermodynamics, Solid** section.
- 3 From the  $p$  list, choose **User defined**. From the  $C_p$  list, choose **User defined**.

### *Initial Values 1*

- 1 In the **Model Builder** window, click **Initial Values 1**.
- 2 In the **Settings** window for **Initial Values**, locate the **Initial Values** section.
- 3 In the  $T$  text field, type  $T_{\text{ext}}$ .

### *Heat Flux 1*

- 1 In the **Physics** toolbar, click  **Boundaries** and choose **Heat Flux**.
- 2 In the **Settings** window for **Heat Flux**, locate the **Boundary Selection** section.
- 3 From the **Selection** list, choose **Cooling Boundaries**.
- 4 Locate the **Heat Flux** section. From the **Flux type** list, choose **Convective heat flux**.
- 5 In the  $h$  text field, type  $hT$ .
- 6 In the  $T_{\text{ext}}$  text field, type  $T_{\text{ext}}$ .

## MULTIPHYSICS

### *Electrochemical Heating 1 (ech1)*

In the **Physics** toolbar, click  **Multiphysics Couplings** and choose **Domain** > **Electrochemical Heating**.

## MATERIALS

### *LiPF6 in 3:7 EC:EMC (Liquid, Li-ion Battery) (mat5)*

- 1 In the **Model Builder** window, under **Component 1 (comp1)** > **Materials** click **LiPF6 in 3:7 EC:EMC (Liquid, Li-ion Battery) (mat5)**.
- 2 In the **Settings** window for **Material**, locate the **Material Contents** section.

3 In the table, enter the following settings:

Property	Variable	Value	Unit	Property group
Thermal conductivity	$k_{iso}$ ; $k_{ii} = k_{iso}$ , $k_{ij} = 0$	0.35 [W/(m·K)]	W/(m·K)	Basic

*Nickel (mat6)*

1 In the **Model Builder** window, click **Nickel (mat6)**.

2 In the **Settings** window for **Material**, locate the **Material Contents** section.

3 In the table, enter the following settings:

Property	Variable	Value	Unit	Property group
Electric conductivity	$\sigma_{iso}$ ; $\sigma_{iij} = \sigma_{iso}$ , $\sigma_{ij} = 0$	1.4e7 [S/m]	S/m	Basic
Thermal conductivity	$k_{iso}$ ; $k_{ii} = k_{iso}$ , $k_{ij} = 0$	100 [W/(m·K)]	W/(m·K)	Basic

## DEFINITIONS

*Linear Extrusion 1 (linext1)*

1 In the **Definitions** toolbar, click  **Nonlocal Couplings** and choose **Linear Extrusion**.

2 In the **Settings** window for **Linear Extrusion**, locate the **Source Selection** section.

3 From the **Geometric entity level** list, choose **Boundary**.

4 From the **Selection** list, choose **Source Boundary 1**.

5 Locate the **Source Vertices** section. Click to select the  **Activate Selection** toggle button.





6 Select Point 31 only.

7 Locate the **Destination Vertices** section. Click to select the  **Activate Selection** toggle button.







8 Select Point 33 only.



9 Locate the **Source Vertices** section. Click to select the  **Activate Selection** toggle button.

10 Select Point 30 only.

- 11 Locate the **Destination Vertices** section. Click to select the  **Activate Selection** toggle button.
- 12 Select Point 32 only.
- 13 Locate the **Source Vertices** section. Click to select the  **Activate Selection** toggle button.
- 14 Select Point 55 only.
- 15 Locate the **Destination Vertices** section. Click to select the  **Activate Selection** toggle button.
- 16 Select Point 57 only.
- 17 Locate the **Source Vertices** section. Click to select the  **Activate Selection** toggle button.
- 18 Select Point 54 only.
- 19 Locate the **Destination Vertices** section. Click to select the  **Activate Selection** toggle button.
- 20 Select Point 56 only.

#### *Linear Extrusion 2 (linext2)*

- 1 In the **Definitions** toolbar, click  **Nonlocal Couplings** and choose **Linear Extrusion**.
- 2 In the **Settings** window for **Linear Extrusion**, locate the **Source Selection** section.
- 3 From the **Geometric entity level** list, choose **Boundary**.
- 4 From the **Selection** list, choose **Source Boundary 2**.
- 5 Click the  **Zoom Extents** button in the **Graphics** toolbar.
- 6 Locate the **Source Vertices** section. Click to select the  **Activate Selection** toggle button.
- 7 Select Point 47 only.
- 8 Click to select the  **Activate Selection** toggle button.
- 9 Select Point 46 only.
- 10 Click to select the  **Activate Selection** toggle button.
- 11 Select Point 38 only.
- 12 Click to select the  **Activate Selection** toggle button.
- 13 Select Point 39 only.
- 14 Locate the **Destination Vertices** section. Click to select the  **Activate Selection** toggle button.

- 15 Select Point 49 only.
- 16 Click to select the  **Activate Selection** toggle button.
- 17 Select Point 48 only.
- 18 Click to select the  **Activate Selection** toggle button.
- 19 Select Point 40 only.
- 20 Click to select the  **Activate Selection** toggle button.
- 21 Select Point 41 only.

## SECONDARY CURRENT DISTRIBUTION (CD)

### *Electrolyte Potential Coupling 1*

- 1 In the **Physics** toolbar, click  **Boundaries** and choose **Electrolyte Potential**.
- 2 In the **Settings** window for **Electrolyte Potential**, type Electrolyte Potential Coupling 1 in the **Label** text field.
- 3 Locate the **Boundary Selection** section. From the **Selection** list, choose **Destination Boundary 1**.
- 4 Locate the **Electrolyte Potential** section. In the  $\phi_{1,\text{bnd}}$  text field, type `linext1(phi1)`.

### *Electrolyte Potential Coupling 2*

- 1 Right-click **Electrolyte Potential Coupling 1** and choose **Duplicate**.
- 2 In the **Settings** window for **Electrolyte Potential**, type Electrolyte Potential Coupling 2 in the **Label** text field.
- 3 Locate the **Boundary Selection** section. From the **Selection** list, choose **Destination Boundary 2**.
- 4 Locate the **Electrolyte Potential** section. In the  $\phi_{1,\text{bnd}}$  text field, type `linext2(phi1)`.

## HEAT TRANSFER IN SOLIDS (HT)

### *Temperature Coupling 1*

- 1 In the **Physics** toolbar, click  **Boundaries** and choose **Temperature**.
- 2 In the **Settings** window for **Temperature**, type Temperature Coupling 1 in the **Label** text field.
- 3 Locate the **Boundary Selection** section. From the **Selection** list, choose **Destination Boundary 1**.
- 4 Locate the **Temperature** section. In the  $T_0$  text field, type `linext1(T)`.

### *Temperature Coupling 2*

- 1 Right-click **Temperature Coupling 1** and choose **Duplicate**.
- 2 In the **Settings** window for **Temperature**, type Temperature Coupling 2 in the **Label** text field.
- 3 Locate the **Boundary Selection** section. From the **Selection** list, choose **Destination Boundary 2**.
- 4 Locate the **Temperature** section. In the  $T_0$  text field, type  $\ln(x^2(T))$ .

### **MESH 1**

#### *Size 1*

- 1 In the **Model Builder** window, under **Component 1 (comp1)** right-click **Mesh 1** and choose **Size**.
- 2 In the **Settings** window for **Size**, locate the **Geometric Entity Selection** section.
- 3 From the **Geometric entity level** list, choose **Edge**.
- 4 From the **Selection** list, choose **Mesh Size Edges**.
- 5 Locate the **Element Size** section. Click the **Custom** button.
- 6 Locate the **Element Size Parameters** section.
- 7 Select the **Maximum element size** checkbox. In the associated text field, type  $H_{\text{tab\_outside\_jr}}/5$ .

#### *Size*

- 1 In the **Model Builder** window, click **Size**.
- 2 In the **Settings** window for **Size**, locate the **Element Size** section.
- 3 Click the **Custom** button.
- 4 Locate the **Element Size Parameters** section. In the **Maximum element size** text field, type  $H_{\text{mesh}}$ .
- 5 In the **Minimum element size** text field, type  $D_{\text{sep}}/2$ .

#### *Free Quad 1*

- 1 In the **Mesh** toolbar, click  **More Generators** and choose **Free Quad**.
- 2 In the **Settings** window for **Free Quad**, locate the **Boundary Selection** section.
- 3 From the **Selection** list, choose **Quad Mesh Boundaries**.

4 Click  **Build Selected.**

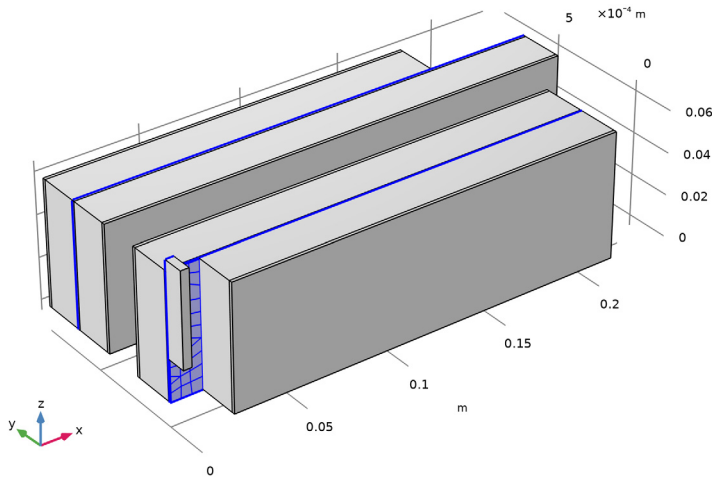

#### *Mapped 1*

- 1 In the **Mesh** toolbar, click  **More Generators** and choose **Mapped**.
- 2 In the **Settings** window for **Mapped**, locate the **Boundary Selection** section.
- 3 From the **Selection** list, choose **Extrusion and Coupling Boundaries**.

#### *Distribution 1*

- 1 Right-click **Mapped 1** and choose **Distribution**.
- 2 In the **Settings** window for **Distribution**, locate the **Edge Selection** section.
- 3 From the **Selection** list, choose **Mapped Mesh Distribution Edges 1**.
- 4 Locate the **Distribution** section. In the **Number of elements** text field, type  $\text{round}(L_{cc\_neg}/H_{\text{mesh}})$ .

#### *Distribution 2*

- 1 In the **Model Builder** window, right-click **Mapped 1** and choose **Distribution**.
- 2 In the **Settings** window for **Distribution**, locate the **Edge Selection** section.
- 3 From the **Selection** list, choose **Mapped Mesh Distribution Edges 2**.
- 4 Locate the **Distribution** section. In the **Number of elements** text field, type  $\text{round}(H_{jr}/H_{\text{mesh}})$ .

5 Click  **Build Selected**.

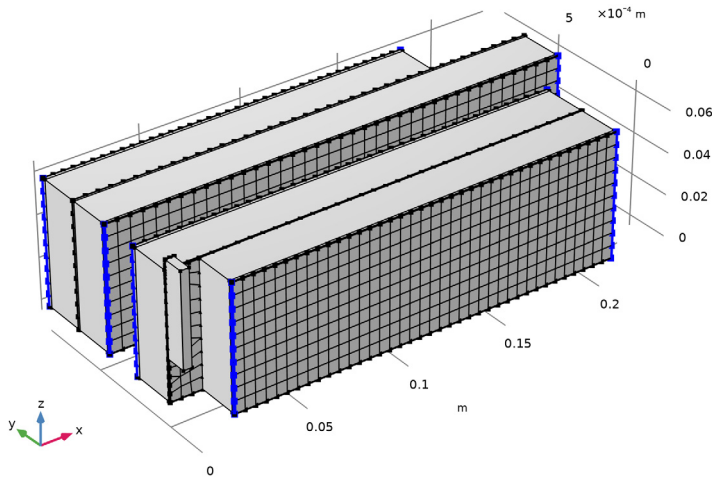

#### *Swept 1*

In the **Mesh** toolbar, click  **Swept**.

#### *Distribution 1*

- 1 Right-click **Swept 1** and choose **Distribution**.
- 2 In the **Settings** window for **Distribution**, locate the **Domain Selection** section.
- 3 From the **Selection** list, choose **Separators**.
- 4 Locate the **Distribution** section. In the **Number of elements** text field, type 2.

#### *Distribution 2*

- 1 In the **Model Builder** window, right-click **Swept 1** and choose **Distribution**.
- 2 In the **Settings** window for **Distribution**, locate the **Domain Selection** section.
- 3 From the **Selection** list, choose **Electrodes**.

#### *Distribution 3*

- 1 Right-click **Swept 1** and choose **Distribution**.
- 2 In the **Settings** window for **Distribution**, locate the **Domain Selection** section.
- 3 From the **Selection** list, choose **CCs and Tabs**.
- 4 Locate the **Distribution** section. In the **Number of elements** text field, type 2.
- 5 Click  **Build All**.

- 6 Click the  **Go to XY View** button in the **Graphics** toolbar.
- 7 In the **Model Builder** window, click **Mesh 1**.



- 8 Click the  **Go to Default View** button in the **Graphics** toolbar.

## STUDY 1

### Step 2: Stationary 2

- 1 In the **Study** toolbar, click  **Stationary**.
- 2 In the **Settings** window for **Stationary**, locate the **Physics and Variables Selection** section.
- 3 In the **Solve for** column of the table, under **Component 1 (comp1)**, clear the checkbox for **Secondary Current Distribution (cd)**.
- 4 In the **Solve for** column of the table, under **Component 1 (comp1)**, select the checkbox for **Heat Transfer in Solids (ht)**.

### Step 1: Stationary

- 1 In the **Model Builder** window, click **Step 1: Stationary**.
- 2 In the **Settings** window for **Stationary**, locate the **Physics and Variables Selection** section.
- 3 In the **Solve for** column of the table, under **Component 1 (comp1)**, select the checkbox for **Secondary Current Distribution (cd)**.
- 4 In the **Solve for** column of the table, under **Component 1 (comp1)**, clear the checkbox for **Heat Transfer in Solids (ht)**.

- 5 In the **Model Builder** window, click **Study 1**.
- 6 In the **Settings** window for **Study**, locate the **Study Settings** section.
- 7 Clear the **Generate default plots** checkbox.
- 8 In the **Study** toolbar, click  **Compute**.

## RESULTS



### *Temperature*



- 1 In the **Results** toolbar, click  **3D Plot Group**.
- 2 In the **Settings** window for **3D Plot Group**, type **Temperature** in the **Label** text field.

### *Volume 1*

- 1 Right-click **Temperature** and choose **Volume**.
- 2 In the **Settings** window for **Volume**, locate the **Expression** section.
- 3 In the **Expression** text field, type **T**.
- 4 Locate the **Coloring and Style** section. From the **Color table** list, choose **HeatCameraLight**.
- 5 Locate the **Expression** section. In the **Unit** field, type **degC**.

### *Temperature*

- 1 In the **Model Builder** window, click **Temperature**.
- 2 In the **Settings** window for **3D Plot Group**, click to expand the **Title** section.
- 3 From the **Title type** list, choose **Label**.
- 4 Locate the **Color Legend** section. Select the **Show maximum and minimum values** checkbox.
- 5 Select the **Show units** checkbox.
- 6 Click the  **Zoom Extents** button in the **Graphics** toolbar.
- 7 In the **Temperature** toolbar, click  **Plot**.

- 8 In the **Graphics** window toolbar, click  next to  **Go to Default View**, then choose **Go to View 1**.

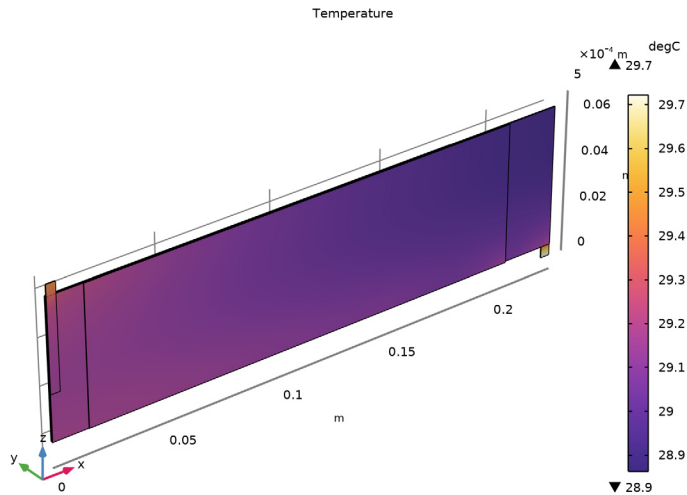

#### *Electrode Potential wrt Negative Terminal*

- 1 In the **Results** toolbar, click  **3D Plot Group**.
- 2 In the **Settings** window for **3D Plot Group**, type Electrode Potential wrt Negative Terminal in the **Label** text field.
- 3 Click to expand the **Selection** section. From the **Geometric entity level** list, choose **Domain**.
- 4 From the **Selection** list, choose **Negative CC and Tab**.
- 5 Locate the **Title** section. From the **Title type** list, choose **Label**.
- 6 Locate the **Color Legend** section. Select the **Show units** checkbox.

#### *Volume 1*

- 1 Right-click **Electrode Potential wrt Negative Terminal** and choose **Volume**.
- 2 In the **Settings** window for **Volume**, click **Replace Expression** in the upper-right corner of the **Expression** section. From the menu, choose **Component 1 (comp1) > Secondary Current Distribution > cd.phis - Electric potential - V**.
- 3 Locate the **Expression** section. From the **Unit** list, choose **mV**.
- 4 Locate the **Coloring and Style** section. From the **Color table** list, choose **Cyanthus**.

- 5 In the **Electrode Potential wrt Negative Terminal** toolbar, click  **Plot**.

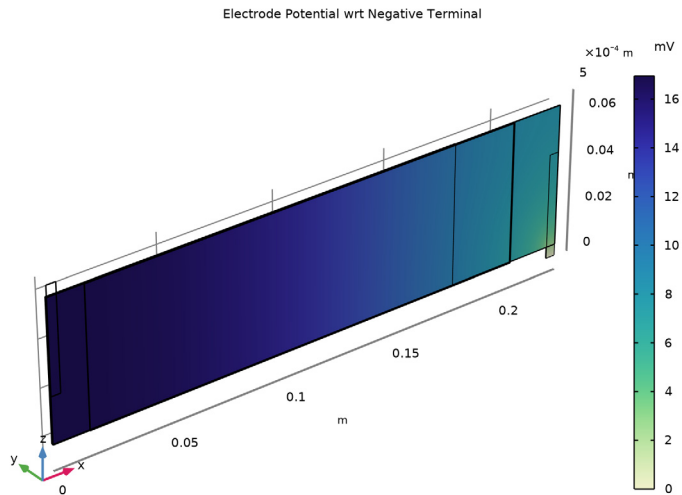

#### *Electrode Potential wrt Positive Terminal*

- 1 In the **Model Builder** window, right-click **Electrode Potential wrt Negative Terminal** and choose **Duplicate**.
- 2 In the **Settings** window for **3D Plot Group**, type **Electrode Potential wrt Positive Terminal** in the **Label** text field.
- 3 Locate the **Selection** section. From the **Selection** list, choose **Positive CC and Tab**.

#### *Volume 1*

- 1 In the **Model Builder** window, expand the **Electrode Potential wrt Positive Terminal** node, then click **Volume 1**.
- 2 In the **Settings** window for **Volume**, click **Insert Expression (Ctrl+Space)** in the upper-right corner of the **Expression** section. From the menu, choose **Component 1 (comp1) > Secondary Current Distribution > cd.phis0\_ec1 - Electric potential on boundary - V**.
- 3 Locate the **Expression** section. In the **Expression** text field, type `cd.phis0_ec1 - cd.phis0_ec1`.
- 4 From the **Unit** list, choose **mV**.
- 5 Locate the **Coloring and Style** section. From the **Color table** list, choose **Metasepia**.

- 6 In the **Electrode Potential wrt Positive Terminal** toolbar, click  **Plot**.

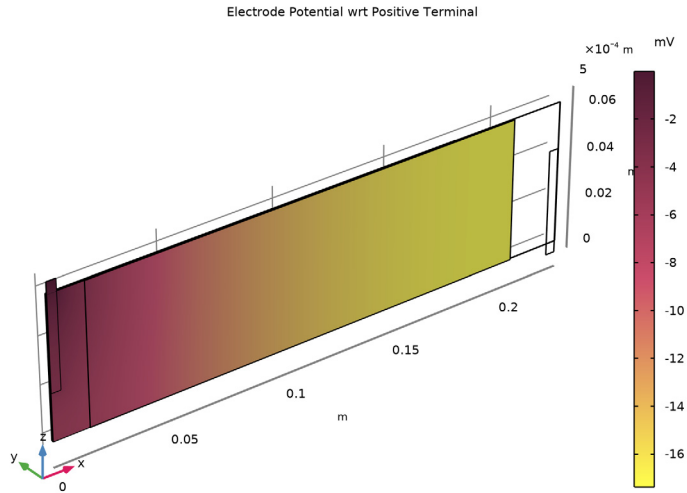

#### *Electrolyte Current Density, Separator 1*

- 1 In the **Results** toolbar, click  **3D Plot Group**.
- 2 In the **Settings** window for **3D Plot Group**, type **Electrolyte Current Density, Separator 1** in the **Label** text field.
- 3 Click to expand the **Selection** section. From the **Geometric entity level** list, choose **Boundary**.
- 4 From the **Selection** list, choose **Destination Boundary 1**.

#### *Surface 1*

- 1 Right-click **Electrolyte Current Density, Separator 1** and choose **Surface**.
- 2 In the **Settings** window for **Surface**, click **Replace Expression** in the upper-right corner of the **Expression** section. From the menu, choose **Component 1 (comp1) > Secondary Current Distribution > cd.n11 - Normal electrolyte current density - A/m<sup>2</sup>**.
- 3 Locate the **Expression** section. In the **Expression** text field, type `abs(cd.n11)`.
- 4 Locate the **Coloring and Style** section. From the **Color table** list, choose **MetasepiaBlue**.

#### *Electrolyte Current Density, Separator 1*

- 1 In the **Model Builder** window, click **Electrolyte Current Density, Separator 1**.
- 2 In the **Settings** window for **3D Plot Group**, locate the **Title** section.
- 3 From the **Title type** list, choose **Manual**.

- 4 In the **Title** text area, type **Current Density (A/m<sup>2</sup>)**.
- 5 In the **Electrolyte Current Density, Separator 1** toolbar, click  **Plot**.

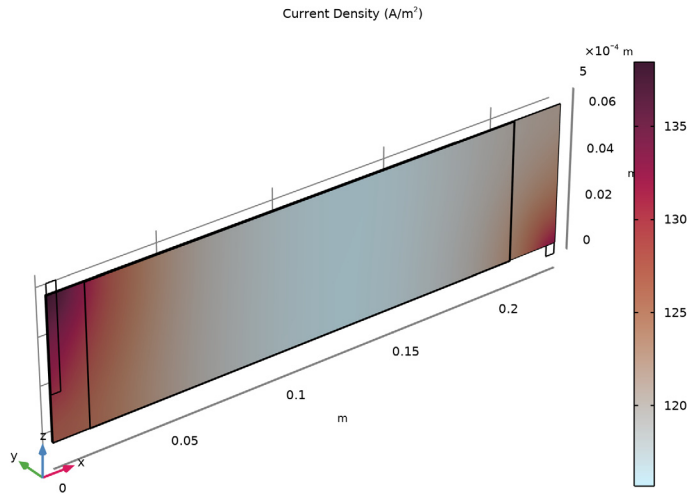

#### *Electrolyte Current Density, Separator 2*

- 1 Right-click **Electrolyte Current Density, Separator 1** and choose **Duplicate**.
- 2 In the **Model Builder** window, click **Electrolyte Current Density, Separator 1.1**.
- 3 In the **Settings** window for **3D Plot Group**, type **Electrolyte Current Density, Separator 2** in the **Label** text field.
- 4 Locate the **Selection** section. From the **Selection** list, choose **Destination Boundary 2**.

5 In the **Electrolyte Current Density, Separator 2** toolbar, click  **Plot**.

