



Model created in COMSOL Multiphysics 6.4

Jelly Roll

Introduction

A lithium battery cell is constructed as a sandwich of different layers (current collector metal foils, porous electrodes, separators), which is placed in an enclosure filled with electrolytes. The configuration of the sandwich depends on the type of enclosure (coin cell, prismatic, pouch, cylinder, and so on). Cylindrical lithium-ion batteries are manufactured by rolling the different battery layers into a cylindrical roll, which is then placed in a metal can. The resulting rolled spiral structure is commonly referred to as a “jelly roll.”

The current collector foils are usually made of copper on the negative side and aluminum on the positive side, with thicknesses around tens of micrometers or less. To conduct the current to and from the jelly roll to the world exterior to the battery can, additional strips of metal are welded to the current collectors. These metal strips are called tabs. The simplest tabbing design, used in low-power batteries, places one tab on each side of the jelly roll (Ref. 1).

The interplay of the various dimensions of the layers and the tabs, in combination with the magnitude of the cell current, governs the temperature and current distribution in the battery cell.

This tutorial models the ohmic and activation losses, and the resulting temperature distribution, in a jelly roll for a pseudostationary case at a constant cell current.

Model Definition

[Figure 1](#) shows the model geometry. The roll is 60 mm high, with a maximum outer spiral radius of 8.5 mm, and a minimum inner radius of 2 mm, including the cell tab. The tabs

extend 5 mm outside the jelly roll, the positive upward from the center of the spiral, the negative downward

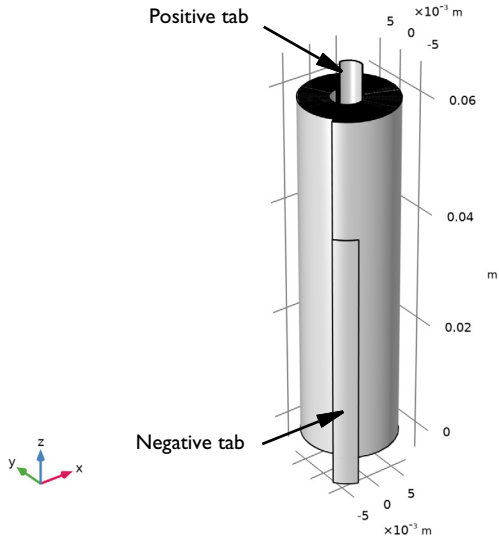

Figure 1: Model geometry.

Parametric curves, based on archimedean spiral functions are used to create the roll cross-sectional geometry, assuming a constant cell thickness. The following materials and thicknesses are used for the different layers, as indicated in [Figure 2](#):

- Positive tab: aluminum, 100 mm thick, 4 mm wide
- Positive current collector: aluminum, 10 mm thick
- Positive electrode: NMC 111, 200 mm thick
- Separator: 30 mm thick
- Negative electrode: graphite, 200 mm thick
- Negative current collector: copper, 10 mm thick
- Negative tab: nickel, 100 mm thick, 4 mm wide

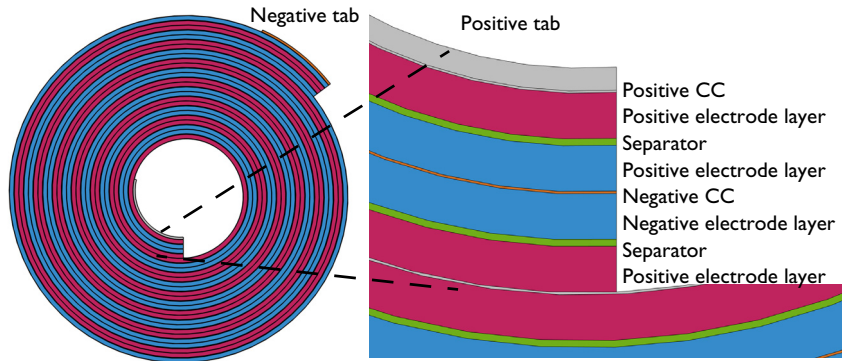

Figure 2: Cross section of the jelly roll.

The model in the tutorial uses a pseudostationary approach, only accounting for the ohmic voltage losses in the electronic conductors and the electrolyte and the activation overpotentials due to the charge transfer reactions in the electrodes. The current distribution is modeled using a **Secondary Current Distribution** interface.

This model is a simplification since it will be excluding any (tertiary) effects due to accumulation or depletion of lithium atoms in the electrodes or ions in the electrolyte. As soon as a current starts running through the battery, local concentration levels will change, which in turn impact the local electrolyte conductivity and equilibrium (half-cell) potentials of the electrodes, which will impact the current distribution over time. However, for a short period of time after turning on the current, a secondary current distribution model can accurately predict the voltage losses in the jelly roll.

In the current distribution model, a ground condition is used at the negative terminal, whereas a IC total current condition is applied at the positive terminal.

The temperature distribution in the jelly roll is modeled using a **Heat Transfer** interface, applying the resulting heat sources from the current distribution model using an **Electrochemical Heating** multiphysics node. A convective cooling boundary condition on the outer area of the jelly roll is used, prescribing a cooling heat flux being proportional to the surface temperature and the exterior temperature (25°C). Heat being conducted through the electric terminals at the tab ends is ignored.

Results and Discussion

Figure 3 and Figure 4 show the simulated potential distribution in the negative and positive current collectors, respectively, for the jelly roll when subjected to a 1C discharge.

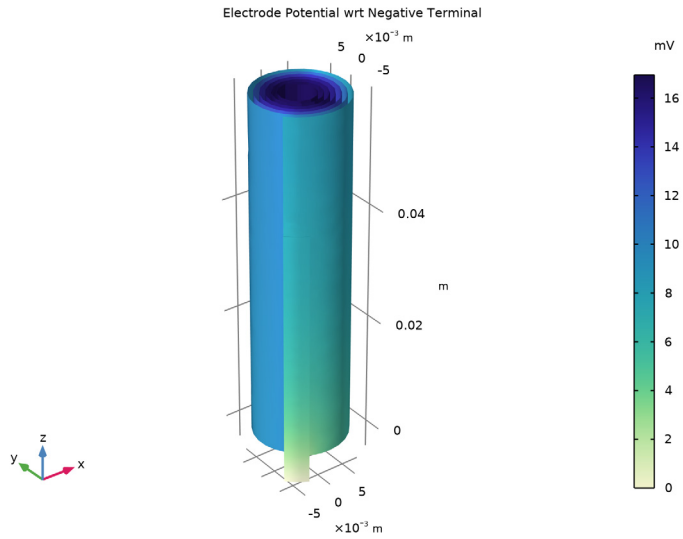

Figure 3: Potential in the negative current collector and tab.

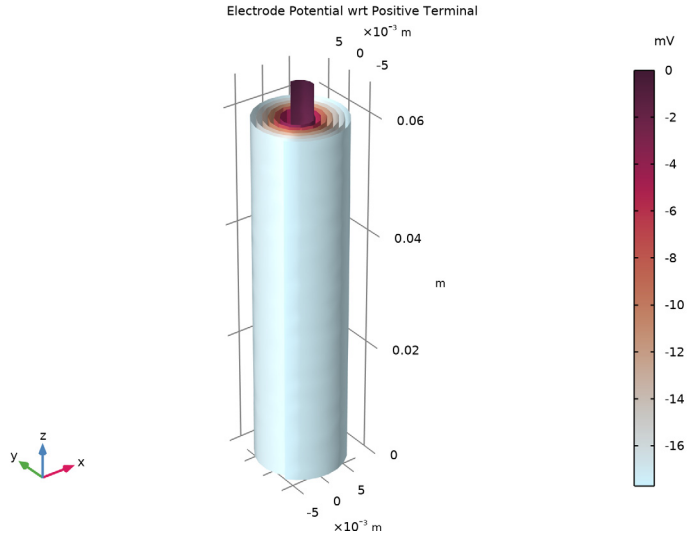

Figure 4: Potential in the positive current collector and tab.

Figure 5 shows a steep increase in temperature in the tabs close to the current terminals. This indicates that the Joule heating in the tabs results in significant local heating already for this fairly small battery at moderate currents. This is important since local temperature differences can result in the battery aging in an inhomogeneous way, which in turn may accelerate aging further.

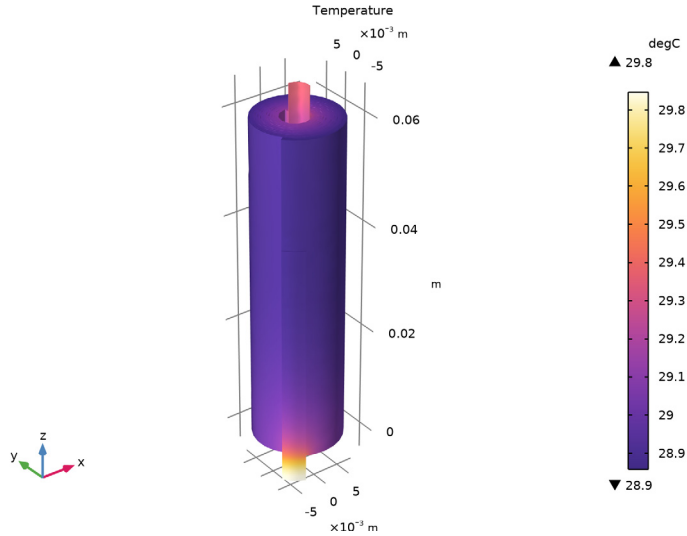

Figure 5: Temperature distribution.

Notes About the COMSOL Implementation

Assembly boundaries are placed in the middle of the separators, thereby allowing for sweeping the meshes in the through-plane direction.

Reference

I. X. Yao and M. Pecht, “Tab Design and Failures in Cylindrical Li-ion Batteries,” *IEEE Access*, vol. 7, pp. 24082–24095, 2019.

Application Library path: Battery_Design_Module/Thermal_Management/
jelly_roll

Modeling Instructions



This model is built in two parts. In the first part, a secondary current distribution model will be defined and solved. In the second part, heat transfer will be included.

From the **File** menu, choose **New**.

NEW

In the **New** window, click  **Model Wizard**.

MODEL WIZARD

- 1 In the **Model Wizard** window, click  **3D**.
- 2 In the **Select Physics** tree, select **Electrochemistry** > **Primary and Secondary Current Distribution** > **Secondary Current Distribution (cd)**.
- 3 Click **Add**.
- 4 Click  **Study**.
- 5 In the **Select Study** tree, select **General Studies** > **Stationary**.
- 6 Click  **Done**.

GEOMETRY I

Insert a geometry sequence from a file.

- 1 In the **Geometry** toolbar, click **Insert Sequence** and choose **Insert Sequence**.
- 2 Browse to the model's Application Libraries folder and double-click the file `jelly_roll_geom_sequence.mph`.
- 3 In the **Geometry** toolbar, click  **Build All**.

- 4 In the **Model Builder** window, under **Component 1 (comp1)** click **Geometry 1**.

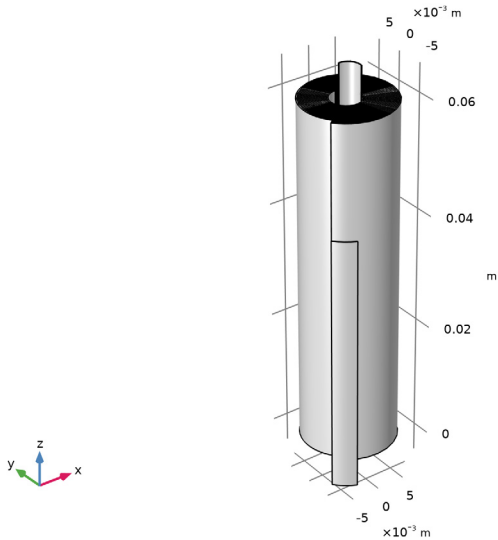

Disable the analysis of the geometry as the remaining small geometric details are needed.

- 5 In the **Model Builder** window, click **Geometry 1**.
- 6 In the **Settings** window for **Geometry**, locate the **Cleanup** section.
- 7 Clear the **Automatic detection of small details** checkbox.
- 8 In the **Geometry** toolbar, click  **Build All**.

GLOBAL DEFINITIONS

Geometry Parameters

By importing the sequence, some parameters were added to the model.

- 1 In the **Model Builder** window, under **Global Definitions** click **Parameters 1**.
- 2 In the **Settings** window for **Parameters**, type Geometry Parameters in the **Label** text field.

Physics Parameters

Import additional parameters, needed to set up the physics, as follows:



- 1 In the **Home** toolbar, click  **Parameters** and choose **Add > Parameters**.
- 2 In the **Settings** window for **Parameters**, type Physics Parameters in the **Label** text field.

- 3 Locate the **Parameters** section. Click  **Load from File**.
- 4 Browse to the model's Application Libraries folder and double-click the file `jelly_roll_parameters.txt`.

GEOMETRY I

In the **Model Builder** window, collapse the **Component I (comp1) > Geometry I** node.

ADD MATERIAL

- 1 In the **Materials** toolbar, click  **Add Material** to open the **Add Material** window.
- 2 Go to the **Add Material** window.
- 3 In the tree, select **Built-in > Aluminum**.
- 4 Right-click and choose **Add to Component I (comp1)**.
- 5 In the tree, select **Built-in > Copper**.
- 6 Right-click and choose **Add to Component I (comp1)**.
- 7 In the tree, select **Battery > Electrodes > Graphite, LixC6 MCMB (Negative, Li-ion Battery)**.
- 8 Right-click and choose **Add to Component I (comp1)**.
- 9 In the tree, select **Battery > Electrodes > NMC 111, LiNi0.33Mn0.33Co0.33O2 (Positive, Li-ion Battery)**.
- 10 Right-click and choose **Add to Component I (comp1)**.
- 11 In the tree, select **Battery > Electrolytes > LiPF6 in 3:7 EC:EMC (Liquid, Li-ion Battery)**.
- 12 Right-click and choose **Add to Component I (comp1)**.
- 13 In the **Materials** toolbar, click  **Add Material** to close the **Add Material** window.

MATERIALS

Aluminum (mat1)

- 1 In the **Settings** window for **Material**, locate the **Geometric Entity Selection** section.
- 2 From the **Selection** list, choose **Positive CC and Tab**.

Copper (mat2)

- 1 In the **Model Builder** window, click **Copper (mat2)**.
- 2 In the **Settings** window for **Material**, locate the **Geometric Entity Selection** section.
- 3 From the **Selection** list, choose **Negative CC**.

Graphite, LixC6 MCMB (Negative, Li-ion Battery) (mat3)

- 1 In the **Model Builder** window, click **Graphite, LixC6 MCMB (Negative, Li-ion Battery) (mat3)**.
- 2 In the **Settings** window for **Material**, locate the **Geometric Entity Selection** section.
- 3 From the **Selection** list, choose **Negative Electrodes**.

NMC 111, LiNi0.33Mn0.33Co0.33O2 (Positive, Li-ion Battery) (mat4)

- 1 In the **Model Builder** window, click **NMC 111, LiNi0.33Mn0.33Co0.33O2 (Positive, Li-ion Battery) (mat4)**.
- 2 In the **Settings** window for **Material**, locate the **Geometric Entity Selection** section.
- 3 From the **Selection** list, choose **Positive Electrodes**.

LiPF6 in 3:7 EC:EMC (Liquid, Li-ion Battery) (mat5)

- 1 In the **Model Builder** window, click **LiPF6 in 3:7 EC:EMC (Liquid, Li-ion Battery) (mat5)**.
- 2 In the **Settings** window for **Material**, locate the **Geometric Entity Selection** section.
- 3 From the **Selection** list, choose **Separators**.

Nickel

The negative tab consists of nickel metal, which is not available in the material library. Add a blank material node for nickel for now. We will add the required parameters later.

- 1 In the **Model Builder** window, right-click **Materials** and choose **Blank Material**.
- 2 In the **Settings** window for **Material**, type `Nickel` in the **Label** text field.
- 3 Locate the **Geometric Entity Selection** section. From the **Selection** list, choose **Negative Tab**.

SECONDARY CURRENT DISTRIBUTION (CD)

Electrolyte 1

Now start defining the current distribution model.

- 1 In the **Model Builder** window, under **Component 1 (comp1) > Secondary Current Distribution (cd)** click **Electrolyte 1**.
- 2 In the **Settings** window for **Electrolyte**, locate the **Electrolyte** section.
- 3 From the σ_1 list, choose **User defined**. In the associated text field, type `sigma1_eff`.

Current Conductor 1

- 1 In the **Physics** toolbar, click  **Domains** and choose **Current Conductor**.
- 2 In the **Settings** window for **Current Conductor**, locate the **Domain Selection** section.

- 3 From the **Selection** list, choose **CCs and Tabs**.

The electrode node defines electronic conduction in the metal phase domains. The conductivity is taken from the Material nodes by default, so no additional settings are needed here.

Porous Electrode I

- 1 In the **Physics** toolbar, click  **Domains** and choose **Porous Electrode**.

The porous electrode node defines both electronic and ionic conduction in the electrode and electrolyte phases, respectively. Since we use the same settings in the positive and negative electrode materials in this tutorial, it suffices to use one single node.

- 2 In the **Settings** window for **Porous Electrode**, locate the **Domain Selection** section.
- 3 From the **Selection** list, choose **Electrodes**.
- 4 Locate the **Electrolyte Current Conduction** section. From the σ_l list, choose **User defined**. In the associated text field, type `sigma_l_eff`.
- 5 From the **Effective conductivity correction** list, choose **No correction**.
- 6 Locate the **Electrode Current Conduction** section. From the σ_s list, choose **User defined**. In the associated text field, type `sigma_s_eff`.
- 7 From the **Effective conductivity correction** list, choose **No correction**.

Porous Electrode Reaction I

In this tutorial we are only interested in the voltage losses, not the resulting cell voltage. Therefore we use the default value of 0 V for the equilibrium potential in both electrodes. The resulting potential at the positive current terminal will thereby equal the total polarization of the cell.

- 1 In the **Model Builder** window, click **Porous Electrode Reaction I**.
- 2 In the **Settings** window for **Porous Electrode Reaction**, locate the **Electrode Kinetics** section.
- 3 From the **Kinetics expression type** list, choose **Butler–Volmer**.
- 4 In the i_0 text field, type `i0`.
- 5 Locate the **Active Specific Surface Area** section. In the a_v text field, type `Av`.

Electric Ground I

- 1 In the **Physics** toolbar, click  **Boundaries** and choose **Electric Ground**.
- 2 In the **Settings** window for **Electric Ground**, locate the **Boundary Selection** section.
- 3 From the **Selection** list, choose **Negative Current Terminal**.

Electrode Current 1

- 1 In the **Physics** toolbar, click  **Boundaries** and choose **Electrode Current**.
- 2 In the **Settings** window for **Electrode Current**, locate the **Boundary Selection** section.
- 3 From the **Selection** list, choose **Positive Current Terminal**.
- 4 Locate the **Electrode Current** section. In the $I_{s,total}$ text field, type I_{-1C} .

MATERIALS

Nickel (mat6)

The Nickel material node is now with a small red cross, indicating a missing parameter value.

- 1 In the **Model Builder** window, under **Component 1 (comp1) > Materials** click **Nickel (mat6)**.
- 2 In the **Settings** window for **Material**, locate the **Material Contents** section.
- 3 In the table, enter the following settings:

Property	Variable	Value	Unit	Property group
Electric conductivity	σ_{iso} ; $\sigma_{ii} =$ σ_{iso} , $\sigma_{ij} = 0$	$1.4e7 [S$ $/m]$	S/m	Basic

The small red cross should now have disappeared.

MESH 1

Create a mesh sequence that sweeps the mesh in the radial direction of the spiral. The boundary faces located between the tabs and the current collector foils are meshed first. In this way, these faces will be used as source boundaries by the sweep operation, and the mid-separator boundaries will be used as destination boundaries. As prerequisite for sweeping the mesh is that, by the way the geometry sequence is set up, assembly boundaries are located in the middle of the separators. Using a geometry without an assembly would not allow for sweeping, since it would introduce faces on the destination boundaries that would not correspond to any faces on the source boundaries.

Size 1



- 1 In the **Model Builder** window, under **Component 1 (comp1)** right-click **Mesh 1** and choose **Size**.
- 2 In the **Settings** window for **Size**, locate the **Geometric Entity Selection** section.

- 3 From the **Geometric entity level** list, choose **Domain**.
- 4 From the **Selection** list, choose **Tabs**.
- 5 Locate the **Element Size** section. Click the **Custom** button.
- 6 Locate the **Element Size Parameters** section.
- 7 Select the **Maximum element size** checkbox. In the associated text field, type $H_{\text{tab_outside_jr}}/5$.

Size

- 1 In the **Model Builder** window, click **Size**.
- 2 In the **Settings** window for **Size**, locate the **Element Size** section.
- 3 Click the **Custom** button.
- 4 Locate the **Element Size Parameters** section. In the **Maximum element size** text field, type H_{mesh} .
- 5 In the **Minimum element size** text field, type $D_{\text{sep}}/2$.

Free Quad 1

- 1 In the **Mesh** toolbar, click  **More Generators** and choose **Free Quad**.
- 2 In the **Settings** window for **Free Quad**, locate the **Boundary Selection** section.
- 3 From the **Selection** list, choose **Initial Mesh Faces**.
- 4 Click  **Build Selected**.

Swept 1

In the **Mesh** toolbar, click  **Swept**.

Distribution 1

- 1 Right-click **Swept 1** and choose **Distribution**.
- 2 In the **Settings** window for **Distribution**, locate the **Domain Selection** section.
- 3 From the **Selection** list, choose **Separators**.
- 4 Locate the **Distribution** section. In the **Number of elements** text field, type 2.

Distribution 2

- 1 In the **Model Builder** window, right-click **Swept 1** and choose **Distribution**.
- 2 In the **Settings** window for **Distribution**, locate the **Domain Selection** section.
- 3 From the **Selection** list, choose **Electrodes**.

Distribution 3

- 1 Right-click **Swept 1** and choose **Distribution**.

- 2 In the **Settings** window for **Distribution**, locate the **Domain Selection** section.
- 3 From the **Selection** list, choose **CCs and Tabs**.
- 4 Locate the **Distribution** section. In the **Number of elements** text field, type 2.

Swept 1

Right-click **Swept 1** and choose **Build All**.

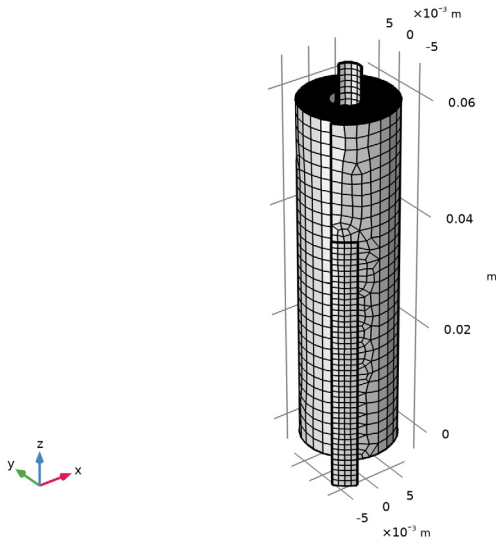

STUDY 1

Now solve the current distribution model.

- 1 In the **Model Builder** window, click **Study 1**.
- 2 In the **Settings** window for **Study**, locate the **Study Settings** section.
- 3 Clear the **Generate default plots** checkbox.
- 4 In the **Study** toolbar, click  **Compute**.

RESULTS

Add plots for the potentials as follows:

Electrode Potential wrt Negative Terminal

- 1 In the **Results** toolbar, click  **3D Plot Group**.
- 2 In the **Settings** window for **3D Plot Group**, type *Electrode Potential wrt Negative Terminal* in the **Label** text field.

- 3 Click to expand the **Selection** section. From the **Geometric entity level** list, choose **Domain**.
- 4 From the **Selection** list, choose **Negative CC and Tab**.

Volume 1

- 1 In the **Model Builder** window, expand the **Electrode Potential wrt Negative Terminal** node.
- 2 Right-click **Electrode Potential wrt Negative Terminal** and choose **Volume**.
- 3 In the **Settings** window for **Volume**, click **Replace Expression** in the upper-right corner of the **Expression** section. From the menu, choose **Component 1 (comp1) > Secondary Current Distribution > cd.phis - Electric potential - V**.
- 4 Locate the **Expression** section. From the **Unit** list, choose **mV**.
- 5 Locate the **Coloring and Style** section. From the **Color table** list, choose **Cyanthus**.

Electrode Potential wrt Negative Terminal

- 1 In the **Model Builder** window, click **Electrode Potential wrt Negative Terminal**.
- 2 In the **Settings** window for **3D Plot Group**, click to expand the **Title** section.
- 3 From the **Title type** list, choose **Label**.
- 4 Locate the **Color Legend** section. Select the **Show units** checkbox.
- 5 Locate the **Plot Settings** section. Clear the **Plot dataset edges** checkbox.
- 6 In the **Electrode Potential wrt Negative Terminal** toolbar, click  **Plot**.

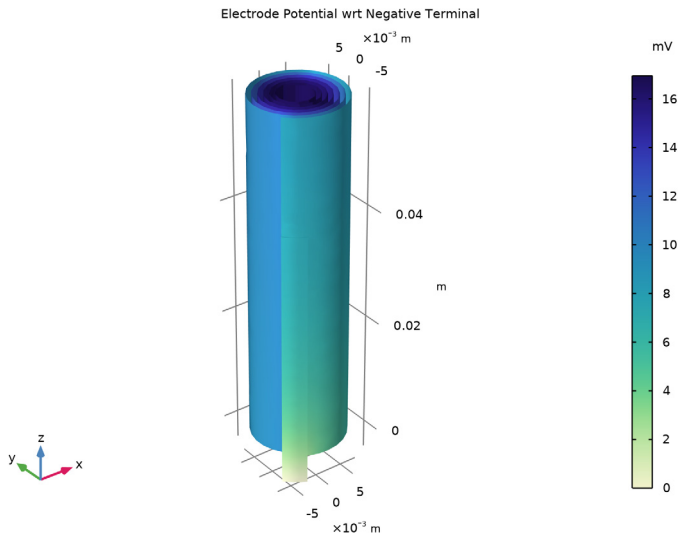

Electrode Potential wrt Positive Terminal

- 1 Right-click **Electrode Potential wrt Negative Terminal** and choose **Duplicate**.
- 2 In the **Settings** window for **3D Plot Group**, type Electrode Potential wrt Positive Terminal in the **Label** text field.

Electrode Potential wrt Negative Terminal

- 1 Click to expand the **Selection** section. From the **Geometric entity level** list, choose **Domain**.
- 2 From the **Selection** list, choose **Positive CC and Tab**.
- 3 In the **Model Builder** window, expand the **Results > Electrode Potential wrt Negative Terminal** node.

Volume I

- 1 In the **Model Builder** window, expand the **Results > Electrode Potential wrt Positive Terminal** node, then click **Volume I**.
- 2 In the **Settings** window for **Volume**, click **Insert Expression (Ctrl+Space)** in the upper-right corner of the **Expression** section. From the menu, choose **Component I (comp1) > Secondary Current Distribution > cd.phis0_ec1 - Electric potential on boundary - V**.
- 3 Locate the **Expression** section. In the **Expression** text field, type `cd.phis0_ec1`.
- 4 From the **Unit** list, choose **mV**.
- 5 Locate the **Coloring and Style** section. From the **Color table** list, choose **MetasepiaBlue**.

Electrode Potential wrt Positive Terminal

- 1 In the **Model Builder** window, click **Electrode Potential wrt Positive Terminal**.

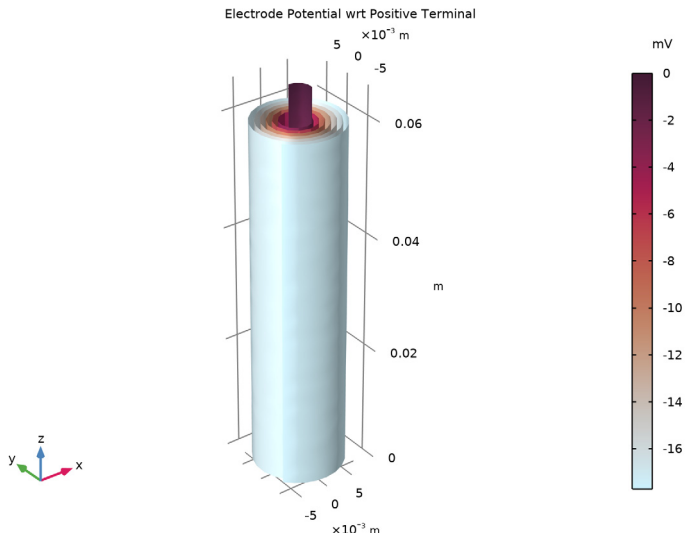

2 In the **Electrode Potential wrt Positive Terminal** toolbar, click  **Plot**.



COMPONENT I (COMP I)

Now we move over to the second part of this tutorial, in which we will include heat transfer.

ADD PHYSICS

- 1 In the **Home** toolbar, click  **Add Physics** to open the **Add Physics** window.
- 2 Go to the **Add Physics** window.
- 3 In the tree, select **Heat Transfer** > **Heat Transfer in Solids (ht)**.
- 4 Click the **Add to Component I** button in the window toolbar.
- 5 In the **Home** toolbar, click  **Add Physics** to close the **Add Physics** window.

HEAT TRANSFER IN SOLIDS (HT)

Solid 1

The default **Solid** node will define heat transfer in all domains. The thermal conductivity is taken from the materials nodes by default. Since we will defining a stationary problem, the density and the heat capacity are not needed.

- 1 In the **Settings** window for **Solid**, locate the **Thermodynamics, Solid** section.
- 2 From the ρ list, choose **User defined**. From the C_p list, choose **User defined**.

Initial Values I

- 1 In the **Model Builder** window, click **Initial Values I**.
- 2 In the **Settings** window for **Initial Values**, locate the **Initial Values** section.
- 3 In the T text field, type T_{ext} .

Heat Flux I

Add a convective heat flux to the outer jelly roll envelope. This condition corresponds to an air-cooled surface using a fairly low air flow velocity.

- 1 In the **Physics** toolbar, click  **Boundaries** and choose **Heat Flux**.
- 2 In the **Settings** window for **Heat Flux**, locate the **Boundary Selection** section.
- 3 From the **Selection** list, choose **Cooling Boundaries**.
- 4 Locate the **Heat Flux** section. From the **Flux type** list, choose **Convective heat flux**.
- 5 In the h text field, type hT .
- 6 In the T_{ext} text field, type T_{ext} .

MULTIPHYSICS

Add an electrochemical heating node. This node will apply the heat sources calculated by the current distribution model to the heat transfer model.

Electrochemical Heating I (echI)

In the **Physics** toolbar, click  **Multiphysics Couplings** and choose **Domain > Electrochemical Heating**.

MATERIALS

We need also to add missing parameters for the thermal conductivity to some of the material nodes.

LiPF6 in 3:7 EC:EMC (Liquid, Li-ion Battery) (mat5)

- 1 In the **Model Builder** window, under **Component 1 (comp1) > Materials** click **LiPF6 in 3:7 EC:EMC (Liquid, Li-ion Battery) (mat5)**.
- 2 In the **Settings** window for **Material**, locate the **Material Contents** section.
- 3 In the table, enter the following settings:

Property	Variable	Value	Unit	Property group
Thermal conductivity	k_{iso} ; $k_{ii} = k_{\text{iso}}$, $k_{ij} = 0$	$0.35 [\text{W}/(\text{m}^2\text{K})]$	$\text{W}/(\text{m}\cdot\text{K})$	Basic

Nickel (mat6)

- 1 In the **Model Builder** window, click **Nickel (mat6)**.
- 2 In the **Settings** window for **Material**, locate the **Material Contents** section.
- 3 In the table, enter the following settings:

Property	Variable	Value	Unit	Property group
Thermal conductivity	k_iso ; kii = k_iso, kij = 0	100 [W/ (m*K)]	W/(m·K)	Basic

HEAT TRANSFER IN SOLIDS (HT)

Lower the discretization order of heat transfer to use linear elements. This will shorten the computation time and lower the memory requirements.

- 1 In the **Model Builder** window, under **Component 1 (comp1)** click **Heat Transfer in Solids (ht)**.
- 2 In the **Settings** window for **Heat Transfer in Solids**, click to expand the **Discretization** section.
- 3 From the **Temperature** list, choose **Linear**.
Alter the study so that you first solve for the current distribution, and then heat transfer model.

STUDY 1

Step 1: Stationary

- 1 In the **Model Builder** window, under **Study 1** click **Step 1: Stationary**.
- 2 In the **Settings** window for **Stationary**, locate the **Physics and Variables Selection** section.
- 3 In the **Solve for** column of the table, under **Component 1 (comp1)**, select the checkbox for **Secondary Current Distribution (cd)**.
- 4 In the **Solve for** column of the table, under **Component 1 (comp1)**, clear the checkbox for **Heat Transfer in Solids (ht)**.

Step 2: Stationary 2

- 1 In the **Study** toolbar, click  **Stationary**.
- 2 In the **Settings** window for **Stationary**, locate the **Physics and Variables Selection** section.
- 3 In the **Solve for** column of the table, under **Component 1 (comp1)**, clear the checkbox for **Secondary Current Distribution (cd)**.

- 4 In the **Solve for** column of the table, under **Component 1 (comp1)**, select the checkbox for **Heat Transfer in Solids (ht)**.

Solution 1 (sol1)

- 1 In the **Model Builder** window, right-click **Solver Configurations** and choose **Reset Solver to Default**.
- 2 Expand the **Solution 1 (sol1)** node.
Inspect the solver sequence. The sequence should now consist of two stationary solvers.
- 3 In the **Model Builder** window, expand the **Study 1 > Solver Configurations > Solution 1 (sol1) > Stationary Solver 2** node.
- 4 Right-click **Study 1** and choose **Compute**.

RESULTS

Create a temperature plot as follows:

Temperature

- 1 In the **Results** toolbar, click  **3D Plot Group**.
- 2 In the **Settings** window for **3D Plot Group**, type **Temperature** in the **Label** text field.

Volume 1

- 1 Right-click **Temperature** and choose **Volume**.
- 2 In the **Settings** window for **Volume**, click **Replace Expression** in the upper-right corner of the **Expression** section. From the menu, choose **Component 1 (comp1) > Heat Transfer in Solids > Temperature > T - Temperature - K**.
- 3 Locate the **Expression** section. In the **Unit** field, type **degC**.
- 4 Locate the **Coloring and Style** section. From the **Color table** list, choose **HeatCameraLight**.

Temperature

- 1 In the **Model Builder** window, click **Temperature**.
- 2 In the **Settings** window for **3D Plot Group**, locate the **Title** section.
- 3 From the **Title type** list, choose **Label**.
- 4 Locate the **Plot Settings** section. Clear the **Plot dataset edges** checkbox.
- 5 Locate the **Color Legend** section. Select the **Show maximum and minimum values** checkbox.
- 6 Select the **Show units** checkbox.

7 In the **Temperature** toolbar, click  **Plot**.

