



Model created in COMSOL Multiphysics 6.4

Wax Guard Acoustics: Transfer Matrix Computation

Introduction

In this tutorial, the acoustic properties of a wax guard are analyzed. A wax guard is a small perforated mesh used to protect the receiver (the miniature loudspeaker in a hearing aid) used for receiver-in-the-ear (RITE) or receiver-in-canal (RIC) hearing aids. Because of the very small dimensions of the structure the thermal and viscous boundary layer losses need to be included in detail, and therefore the *Thermoviscous Acoustics, Frequency Domain* interface is used.

In the first step, the transfer matrix (or two-port) of the wax guard is computed using the *Port Sweep* functionality and the *Port* boundary conditions. The wax guard geometry is imported from a CAD file and prepared for simulation.

In the second step, the response of the wax guard subsystem, when placed in a typical measurement setup, is computed and compared to actual measurements. This is done using the lumped transfer matrix approach. The computed wax guard transfer matrix is used together with other transfer matrix components for a receiver (miniature loudspeaker), a narrow pipe, and a coupler volume.

Note: In this model, the NanoCare wax guard CAD geometry, receiver transfer matrix data, coupler transfer matrix data, microphone impedance data, and measurement data are copyright by Widex¹.

Model Definition

WAX GUARDS

A wax guard is a small replaceable protective mesh that is use for receiver-in-the-ear (RITE) or receiver-in.canal (RIC) hearing aids. The mesh is placed in a small structure that can be removed and replaced using a custom tool. An illustration of the location of the wax guard in the micro loudspeaker assembly is given in [Figure 1](#). The system is located inside an earmold and placed in the ear canal of the hearing aid user. In hearing aids, the

1. “Widex” covers Widex A/S and Affiliates. “Affiliate” means a legal entity, now or hereafter, directly or indirectly, owned or controlled by, or owning or controlling, or under common control with by one of the Parties, but such legal entity shall be deemed to be an Affiliate only so long as such ownership or control exists. For purposes of this definition “control” of a legal entity shall mean to have, directly or indirectly, the power to direct or cause the direction of the management and policies of a legal entity, whether (a) through the ownership of voting securities entitling to the right to elect or appoint, directly or indirectly, the majority of the board of directors, or a similar managing authority; (b) by contract; or (c) otherwise. For purposes of this definition, Widex A/S, Sivantos Pte Ltd, together with their Affiliates, are Affiliates of each other.

miniature loudspeaker is commonly referred to as the receiver. This is why this type of hearing aids is called receiver-in-the-ear (RITE) or receiver-in-canal (RIC). The receiver system is powered through the wire that is also seen in Figure 1. The wire is connected to the main body of the hearing aid that is located behind the ear of the user. The microphones, battery, and electronics are located in the body of the hearing aid.

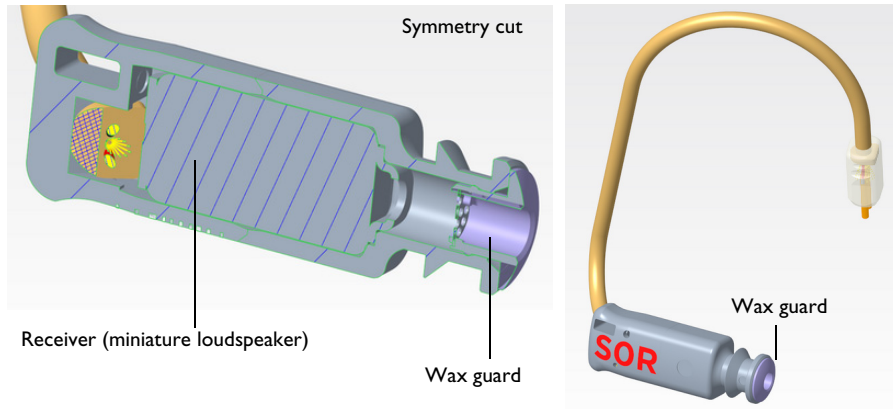

Figure 1: Illustration of the receiver assembly and location of the wax guard. SOR here stands for the type Small, of length 0, and Right ear. The pictures are copyright by Widex.

The geometry of the wax guard is depicted in Figure 2 in various views. The diameter of the main duct is 1 mm, the length of the wax guard is 1.6 mm, the thickness of the perforated plate (the mesh) is 50 μm , and the diameter of a perforate (mesh hole) is 190 μm .

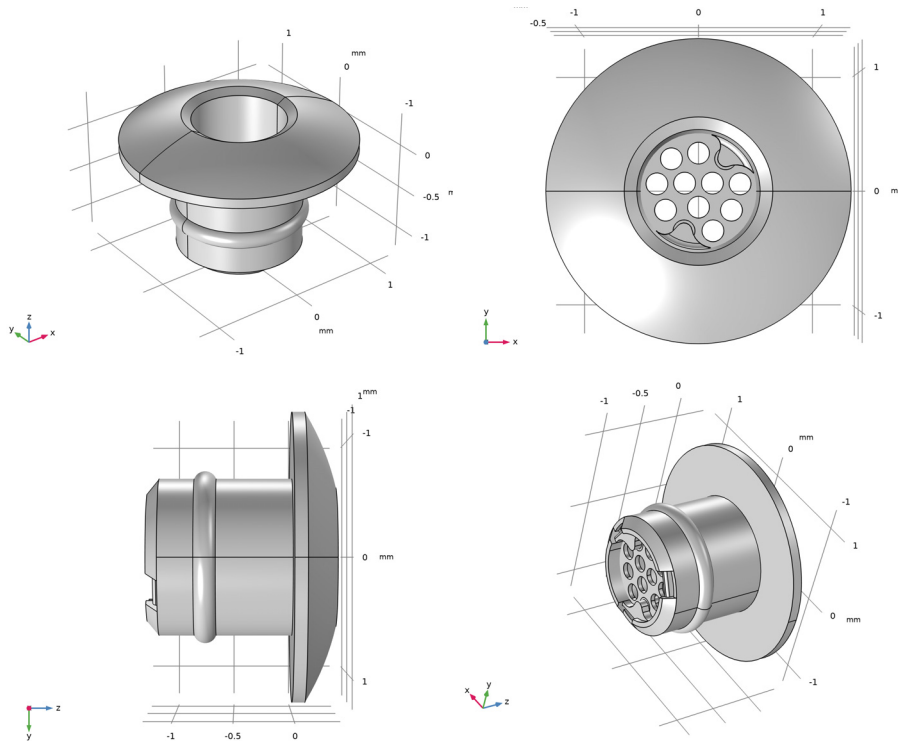

Figure 2: Wax guard geometry. CAD geometry is copyright by Widex.

MODEL SETUP

In this tutorial the acoustic properties of the wax guard are analyzed. Because the dimensions of the system are small (sub mm), it is important to capture the losses associated with the thermal and viscous acoustic boundary layers. The model is solved in the frequency domain with the *Thermoviscous Acoustics, Frequency Domain* physics interface. The transfer matrix of the system is computed using the *Port* boundary condition. Because the ports assume plane wave propagation, they need to be located away from any sudden geometry changes (like the perforated plate in the wax guard). In order to do this, an inlet tube of length 1 mm is added to the geometry. The simulation domain is the air volume inside the wax guard including the inlet tube, as depicted in [Figure 3](#).

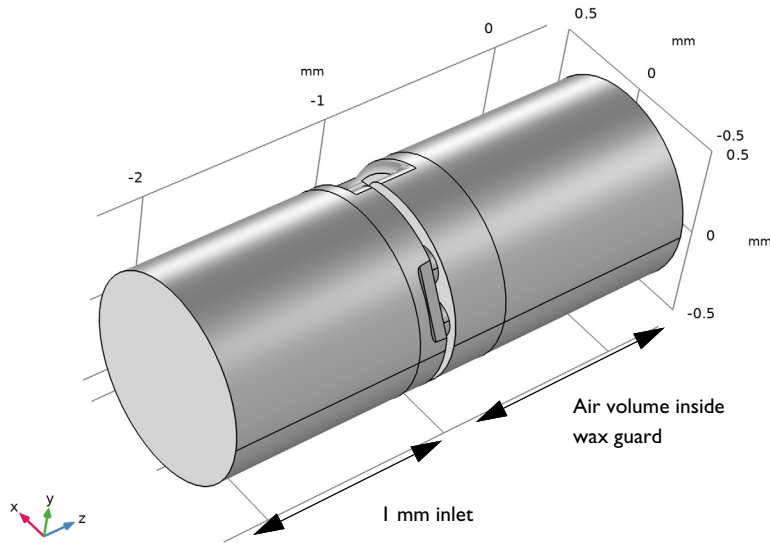
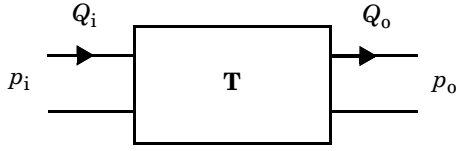

Figure 3: Simulation domain consisting of the air domain inside the wax guard as well as the extra inlet tube.

TRANSFER MATRIX

A transfer matrix (also known as a two-port matrix or a transmission matrix) is a lumped representation of a system consisting of an inlet and an outlet. In the case of a pure acoustic system the matrix relates the pressure and volume flow at the inlet (p_i, Q_i) and outlet (p_o, Q_o), see image below. For an electroacoustic transducer the transfer matrix will relate the voltage and current at the transducer terminal to the pressure and volume flow at the acoustic side. A classical introduction to transfer matrices used in electroacoustic applications is given in [Ref. 1](#). The transfer matrix representation is valid for plane-wave propagation in the acoustic system. Because of the small dimensions in most hearing aid applications, only plane waves propagate in the audible range from 20 Hz to 20 kHz. This makes the use of the transfer matrix analogy very attractive and it is often used for prototyping new designs. It is important to acknowledge that because of the small dimensions, the transfer matrix representation needs to include the thermal and viscous boundary layer losses.



A schematic representation of a two-port system is given in the schematic above (notice the orientation of the volume flow). The associated transfer matrix \mathbf{T} and the port values are related through

$$\begin{bmatrix} p_i \\ Q_i \end{bmatrix} = \begin{bmatrix} T_{11} & T_{12} \\ T_{21} & T_{22} \end{bmatrix} \begin{bmatrix} p_o \\ Q_o \end{bmatrix} \quad \mathbf{T} = \begin{bmatrix} T_{11} & T_{12} \\ T_{21} & T_{22} \end{bmatrix}$$

For a receiver (micro speaker) the input consists of a voltage V_i and current I_i , instead of a pressure and volume flow. For a microphone, the output will have electric units as well. For systems consisting of several components (transducer, ducts, couplers, and so on) the full system transfer matrix is computed by matrix multiplication (from the left) of the individual transfer matrices. Notice that the output of the first component is the input of the next and so forth.

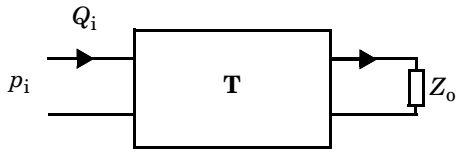

A system is typically terminated with an impedance as in the above schematic. In the acoustic case, the output impedance is an acoustic impedance $Z_o = p_o/Q_o$ (SI unit: $\text{Pa}\cdot\text{s}/\text{m}^3$). The impedance can, for example, represent a radiation impedance, a coupler volume compliance, or the mechanical properties of a microphone. Two useful relations for such systems are the associated input impedance and the transfer function. The input impedance is given by

$$Z_i = \frac{p_i}{Q_i} = \frac{T_{11}Z_o + T_{12}}{T_{21}Z_o + T_{22}} \quad (1)$$

and the transfer function is given by

$$\frac{p_o}{p_i} = \left(T_{11} + \frac{T_{12}}{Z_o} \right)^{-1} \quad (2)$$

Analytical expressions exist for various transfer matrices and can be found in the literature. One important transfer matrix in micro-acoustics and in hearing aids is that of a narrow cylindrical duct of length L and radius a , see [Ref. 2](#) and [Ref. 3](#). The model that includes thermoviscous boundary layer losses is given by

$$\mathbf{T} = \begin{bmatrix} \cos(k_c L) & -\frac{Z_c}{iS} \sin(k_c L) \\ \frac{iS}{Z_c} \sin(k_c L) & \cos(k_c L) \end{bmatrix} \quad \begin{aligned} k_v^2 &= \frac{-i\omega\rho}{\mu} \\ k_{th}^2 &= \frac{-i\omega\rho C_p}{k} \end{aligned}$$

$$k_0 = \frac{\omega}{c} \quad Z_0 = \rho c \quad S = \pi a^2 \quad (3)$$

$$Y_v = \frac{-J_2(k_v a)}{J_0(k_v a)} \quad Y_{th} = \frac{-J_2(k_{th} a)}{J_0(k_{th} a)}$$

$$Z_c^2 = \frac{Z_0^2}{Y_v(\gamma - (\gamma - 1))Y_{th}} \quad k_c^2 = \frac{k_0^2(\gamma - (\gamma - 1))Y_{th}}{Y_v}$$

This expression is used in the tutorial model and defined under **Variables: Narrow Tube Transfer Matrix**. The transfer matrix components of transducers are often measured using the so-called two load method.

For any subsystem, the transfer matrix components can also be computed using the port boundary conditions and port sweep functionality available in the Acoustics Module (both in pressure acoustics and in thermoviscous acoustics). If two port boundary conditions are added to a system and the port sweep option is enabled, the transfer matrix between the inlet (first port added) and the outlet (second port added) is automatically computed. The values of the transfer matrix can be postprocessed, in thermoviscous acoustics the four components are `ta.T11`, `ta.T12`, `ta.T21`, and `ta.T22`, respectively. Transfer matrix parameters are only computed if two and only two ports are added, while the scattering matrix of the system is computed also for multiport configurations.

In this tutorial, the simulated system consists of an inlet duct of length 1 mm and the wax guard. Their total transfer matrix (which is the output of the model) is given by

$$\mathbf{T}_{total} = \mathbf{T}_{tube} \mathbf{T}_{wax\ guard} \quad (4)$$

which implies that the wax guard transfer matrix is computed as

$$\mathbf{T}_{\text{wax guard}} = \mathbf{T}_{\text{tube}}^{-1} \mathbf{T}_{\text{total}} \quad (5)$$

The tube transfer matrix and its inverse is defined in the model as we set up a matrix inverse variable (`matinv1`). The wax guard transfer matrix is defined by a normal matrix variable (`Twg`).

TEST SETUP

In one set of measurements the wax guard is placed in a test setup consisting of a receiver (micro loudspeaker), a receiver tube of length $L_{\text{rt}} = 1.19$ mm and radius $a_{\text{rt}} = 0.725$ mm, the wax guard, a coupler (artificial ear canal simulator), and a measurement microphone. The system is represented schematically below.

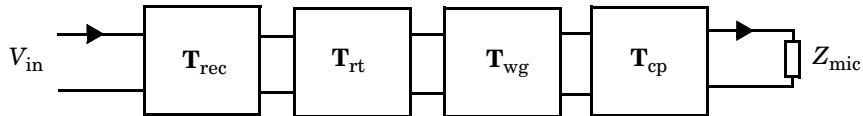

In the tutorial model the wax guard transfer matrix \mathbf{T}_{wg} is computed as described above. The receiver-tube matrix \mathbf{T}_{rt} is defined using [Equation 3](#), while values for the receiver matrix \mathbf{T}_{rec} (a typical receiver used in hearing aids), the coupler matrix \mathbf{T}_{cp} (a typical measurement coupler of the 711-type), and the microphone impedance Z_{mic} are imported as interpolation functions. These are provided by Widex and are copyright by Widex. Note that the coupler transfer matrix could be computed by modifying the tutorial model [Generic 711 Coupler — An Occluded Ear-Canal Simulator](#) placing a port at the inlet and outlet, and doing a port sweep, just as in this model.

Results and Discussion

The acoustic pressure (using a nonsymmetric color scale) is depicted at 10 kHz in [Figure 4](#). The instantaneous velocity and the temperature variations at 1 kHz are depicted in [Figure 5](#) and [Figure 6](#), respectively. In the model, the frequency parameter can be changed in order to visualize the extend of the viscous and thermal boundary layers. The port exciting the system can also be changed (either the inlet or the outlet).

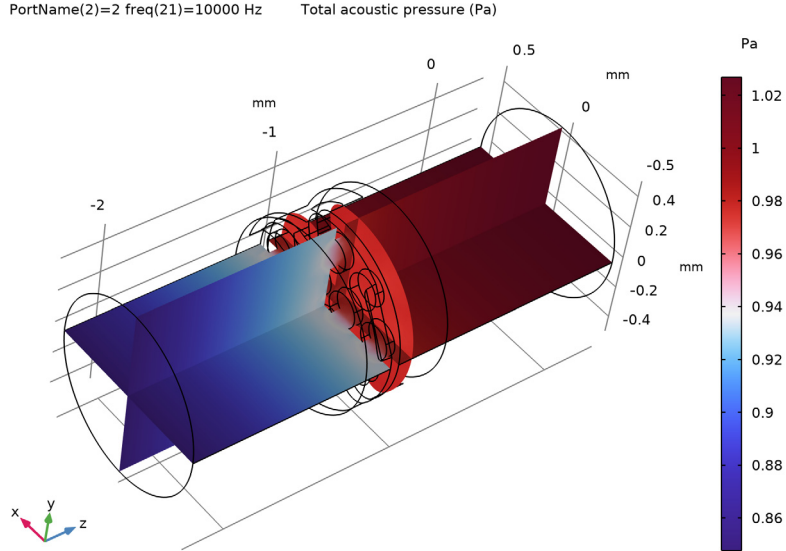

Figure 4: Pressure distribution at 10 kHz, for the port excitation the outlet.

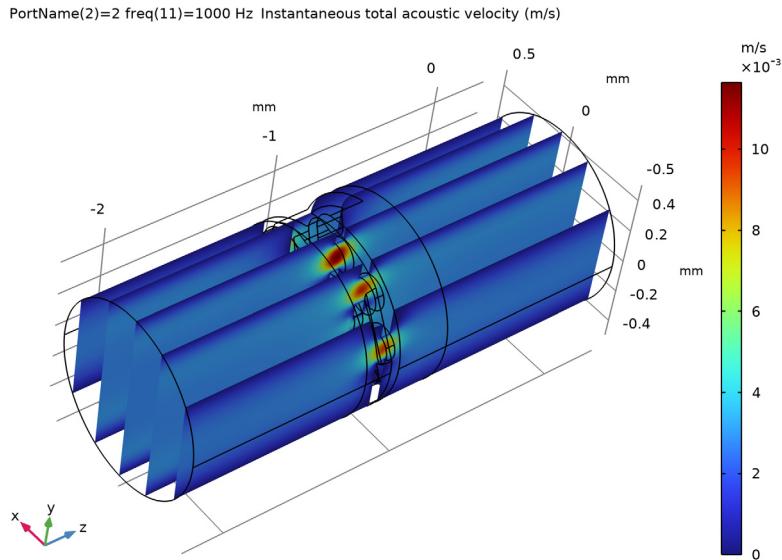

Figure 5: Velocity distribution at 1 kHz, with the port excitation at the outlet.

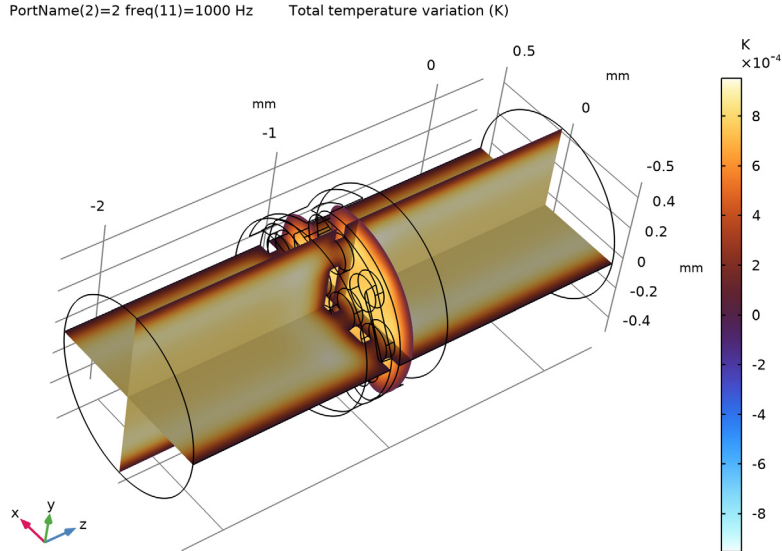

Figure 6: Temperature variation distribution at 1 kHz, with the port excitation at the outlet.

The values of the full system transfer matrix components are depicted in Figure 7 in four different plots. The plots contain the real and imaginary parts of the four matrix components. The computed transfer matrix components of the wax guard, using Equation 5, are depicted in Figure 8. The real and imaginary values are also computed in the **Evaluation Group: Wax Guard, T Matrix (real/imag)** node and represented in a table. The values can be exported to a text file using the **Export** button. In this way the transfer matrix of the wax guard subsystem can be imported and used in a lumped system simulation tool.

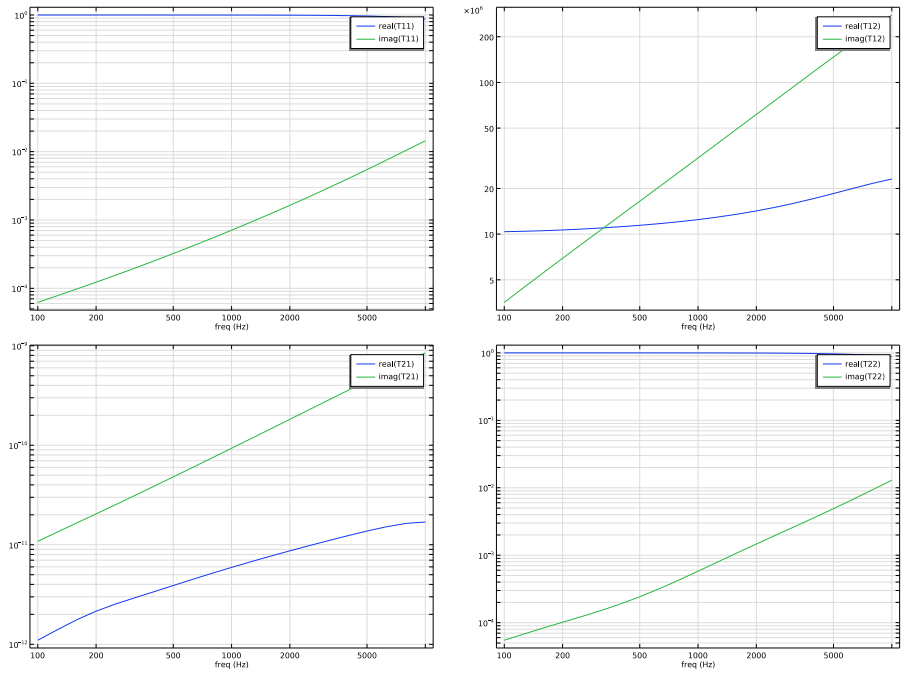

Figure 7: Transfer matrix components of full system (wax guard and inlet tube).

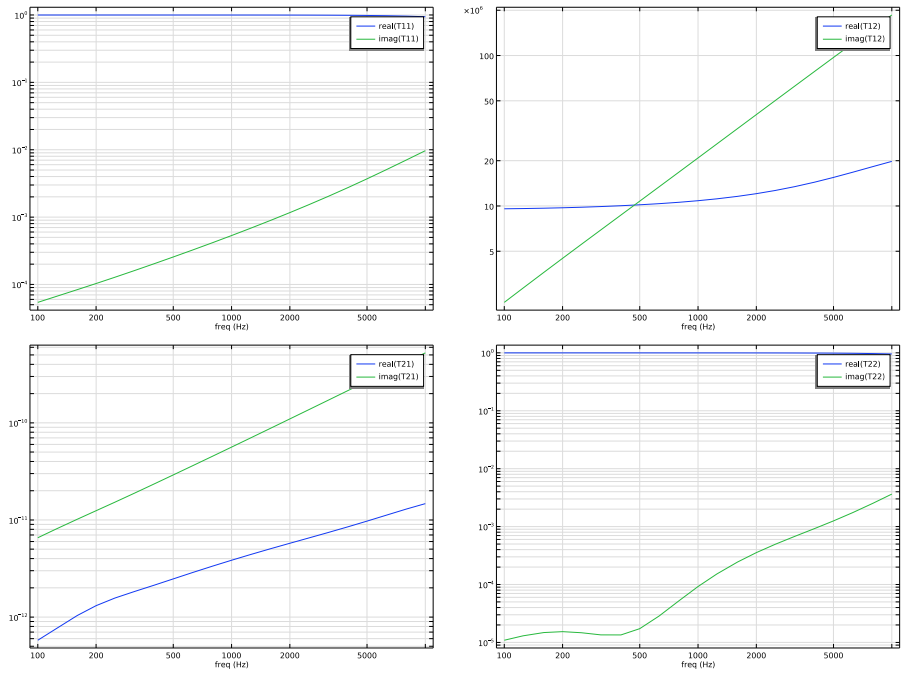

Figure 8: Computed transfer matrix components of wax guard.

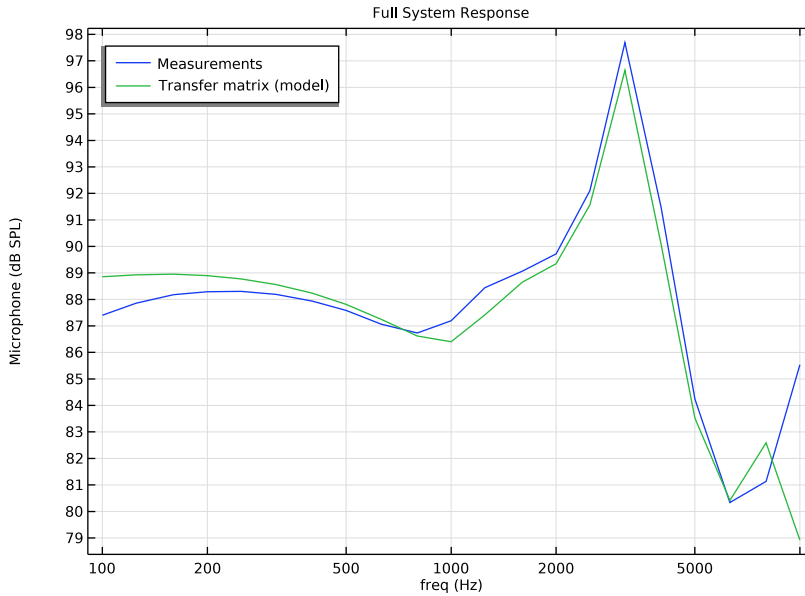

Figure 9: Comparison of simulation and measurements of the SPL response measured at the microphone in the coupler. The measurements are copyright by Widex.

The response of a typical measurement setup that includes the wax guard is depicted in Figure 9. The graph shows the sound pressure level at the measurement microphone in a coupler volume, when the driver has a 0.1 V peak input harmonic signal. The graph shows a comparison between measurements and the system modeled using the transfer matrix approach. The transfer matrix used for the wax guard is the one computed in the model. The system response is computed using Equation 2 (with the input pressure replaced by an input voltage). The measurements and simulation show good agreement up to about 6 kHz. At high frequencies the lumped representation of the receiver (miniature loudspeaker) is not fully valid.

References

1. M. Lampton, "Transmission Matrices in electroacoustics," *Acoustica*, vol. 39, pp 239–251, 1978.
2. H. Tijdeman, "On the propagation of sound waves in cylindrical tubes," *J. Sound Vib.*, vol. 39, pp. 1–33, 1975.

3. M.R. Stinson, “The propagation of plane sound waves in narrow and wide circular tubes, and generalization to uniform tubes of arbitrary cross sectional shapes,” *J. Acoust. Soc. Am.*, vol. 89, pp. 550–558, 1991.

Application Library path: Acoustics_Module/Tutorials,
_Thermoviscous_Acoustics/wax_guard_acoustics

Modeling Instructions



The following shows the modeling instructions. The geometry is set up in the [Detailed Geometry Instructions](#) section at the end of this document.

From the **File** menu, choose **New**.

NEW

In the **New** window, click  **Model Wizard**.

MODEL WIZARD

- 1 In the **Model Wizard** window, click  **3D**.
- 2 In the **Select Physics** tree, select **Acoustics** > **Thermoviscous Acoustics** > **Thermoviscous Acoustics, Frequency Domain (ta)**.
- 3 Click **Add**.
- 4 Click  **Study**.
- 5 In the **Select Study** tree, select **General Studies** > **Frequency Domain**.
- 6 Click  **Done**.

Set up and import two sets of parameters and variables, then set up a global material. The material values are used in the variables that define the transfer matrix of a narrow tube and it will be used in the model (using a material link). For postprocessing the results of the model you will get back to the **Global Definitions** node and import data as well as define various transfer matrices.



GLOBAL DEFINITIONS

Parameters: Model

- 1 In the **Model Builder** window, under **Global Definitions** click **Parameters I**.
- 2 In the **Settings** window for **Parameters**, type Parameters: Model in the **Label** text field.

- 3 Locate the **Parameters** section. Click  **Load from File**.
- 4 Browse to the model's Application Libraries folder and double-click the file `wax_guard_acoustics_parameters.txt`.



Parameters: Tube Segments

- 1 In the **Home** toolbar, click  **Parameters** and choose **Add > Parameters**.
- 2 In the **Settings** window for **Parameters**, type Parameters: Tube Segments in the **Label** text field.
- 3 Locate the **Parameters** section. Click  **Load from File**.
- 4 Browse to the model's Application Libraries folder and double-click the file `wax_guard_acoustics_parameters_tubes.txt`.

Variables: Narrow Tube Transfer Matrix

- 1 In the **Model Builder** window, right-click **Global Definitions** and choose **Variables**.
- 2 In the **Settings** window for **Variables**, type Variables: Narrow Tube Transfer Matrix in the **Label** text field.
- 3 Locate the **Variables** section. Click  **Load from File**.
- 4 Browse to the model's Application Libraries folder and double-click the file `wax_guard_acoustics_variables.txt`.

ADD MATERIAL

- 1 In the **Materials** toolbar, click  **Add Material** to open the **Add Material** window.
- 2 Go to the **Add Material** window.
- 3 In the tree, select **Built-in > Air**.
- 4 Click the **Add to Global Materials** button in the window toolbar.
- 5 In the **Materials** toolbar, click  **Add Material** to close the **Add Material** window.

Next, import the CAD model of the wax guard. Define the air domain and perform some virtual operations to prepare the geometry for modeling and meshing. The geometry is of an actual NanoCare wax guard and is copyright by Widex.

GEOMETRY I

Check to see if your **Geometry representation** setting is set to the CAD kernel. This is required to import the model geometry and requires the CAD Import Module. If the COMSOL kernel is selected proceed with the next step.

- 1 In the **Model Builder** window, under **Component 1 (comp1)** click **Geometry 1**.
- 2 In the **Settings** window for **Geometry**, locate the **Advanced** section.

- 3 From the **Geometry representation** list, choose **CAD kernel**.

Import the geometry as a sequence from a file. To see the detailed instructions go to the last section in this document.

The imported wax guard CAD geometry, used in the imported geometry sequence, is depicted in [Figure 2](#). The imported CAD file is of the device (the wax guard). The air domain inside (the simulation domain of the acoustics) is created together with a 1 mm inlet section.

- 4 In the **Geometry** toolbar, click **Insert Sequence** and choose **Insert Sequence**.
- 5 Browse to the model's Application Libraries folder and double-click the file `wax_guard_acoustics_geom_sequence.mph`.
- 6 In the **Geometry** toolbar, click  **Build All**.

The finalized geometry should look like the one in [Figure 3](#).

MATERIALS

Material Link: Air

- 1 In the **Model Builder** window, under **Component 1 (comp1)** right-click **Materials** and choose **More Materials > Material Link**.
- 2 In the **Settings** window for **Material Link**, type `Material Link: Air` in the **Label** text field.

Set up selections used in physics and meshing.

DEFINITIONS

All domains

- 1 In the **Definitions** toolbar, click  **Explicit**.
- 2 In the **Settings** window for **Explicit**, type `All domains` in the **Label** text field.
- 3 Locate the **Input Entities** section. Select the **All domains** checkbox.

Inlet (port 1)

- 1 In the **Definitions** toolbar, click  **Explicit**.
- 2 In the **Settings** window for **Explicit**, type `Inlet (port 1)` in the **Label** text field.
- 3 Locate the **Input Entities** section. From the **Geometric entity level** list, choose **Boundary**.
- 4 Select **Boundary 3** only.

Outlet (port 2)

- 1 In the **Definitions** toolbar, click  **Explicit**.

- 2 In the **Settings** window for **Explicit**, type Outlet (port 2) in the **Label** text field.
- 3 Locate the **Input Entities** section. From the **Geometric entity level** list, choose **Boundary**.
- 4 Select Boundary 14 only.

All exterior boundaries

- 1 In the **Definitions** toolbar, click  **Adjacent**.
- 2 In the **Settings** window for **Adjacent**, type All exterior boundaries in the **Label** text field.
- 3 Locate the **Input Entities** section. Under **Input selections**, click **+ Add**.
- 4 In the **Add** dialog, select **All domains** in the **Input selections** list.
- 5 Click **OK**.

Walls (boundary layer mesh)

- 1 In the **Definitions** toolbar, click  **Difference**.
- 2 In the **Settings** window for **Difference**, type Walls (boundary layer mesh) in the **Label** text field.
- 3 Locate the **Geometric Entity Level** section. From the **Level** list, choose **Boundary**.
- 4 Locate the **Input Entities** section. Under **Selections to add**, click **+ Add**.
- 5 In the **Add** dialog, select **All exterior boundaries** in the **Selections to add** list.
- 6 Click **OK**.
- 7 In the **Settings** window for **Difference**, locate the **Input Entities** section.
- 8 Under **Selections to subtract**, click **+ Add**.
- 9 In the **Add** dialog, in the **Selections to subtract** list, choose **Inlet (port 1)** and **Outlet (port 2)**.
- 10 Click **OK**.

THERMOVISCOUS ACOUSTICS, FREQUENCY DOMAIN (TA)

Thermoviscous Acoustics Model 1

- 1 In the **Model Builder** window, under **Component 1 (comp1) > Thermoviscous Acoustics, Frequency Domain (ta)** click **Thermoviscous Acoustics Model 1**.
- 2 In the **Settings** window for **Thermoviscous Acoustics Model**, locate the **Model Input** section.
- 3 In the p_0 text field, type pA.
- 4 In the T_0 text field, type T0.

Port 1

- 1 In the **Physics** toolbar, click  **Boundaries** and choose **Port**.
- 2 In the **Settings** window for **Port**, locate the **Boundary Selection** section.
- 3 From the **Selection** list, choose **Inlet (port 1)**.
- 4 Locate the **Port Properties** section. From the **Type of port** list, choose **Circular (0,0)-mode**.
- 5 Locate the **Incident Mode Settings** section. In the A_p^{in} text field, type 1.

Port 2

- 1 In the **Physics** toolbar, click  **Boundaries** and choose **Port**.
- 2 In the **Settings** window for **Port**, locate the **Boundary Selection** section.
- 3 From the **Selection** list, choose **Outlet (port 2)**.
- 4 Locate the **Port Properties** section. From the **Type of port** list, choose **Circular (0,0)-mode**.
- 5 In the **Model Builder** window, click **Thermoviscous Acoustics, Frequency Domain (ta)**.
- 6 In the **Settings** window for **Thermoviscous Acoustics, Frequency Domain**, locate the **Global Port Settings** section.
- 7 From the **Port sweep settings** list, choose **Activate port sweep**.

Notice the parameter `PortName` shown in the **Sweep parameter name** field, it is also present in the **Parameters: Model** list. The parameter was added when loading the parameter file. In general, when selecting **Activate port sweep** the parameter has to be manually added. This parameter is used in a parametric sweep in the study.

Proceed and create the mesh. Use a well resolved tetrahedral mesh near the perforated plate and a swept mesh for the remaining domains. Then add a boundary layer mesh to resolve the viscous and thermal boundary layers. The parameter `dvisc` gives a measure of the layer thickness at the largest frequency studied.

MESH 1

Free Tetrahedral 1

In the **Mesh** toolbar, click  **Free Tetrahedral**.

Size

- 1 In the **Model Builder** window, click **Size**.
- 2 In the **Settings** window for **Size**, locate the **Element Size** section.
- 3 Click the **Custom** button.

- 4 Locate the **Element Size Parameters** section. In the **Maximum element size** text field, type 100[um].
- 5 In the **Minimum element size** text field, type 40[um].
- 6 In the **Curvature factor** text field, type 0.5.
- 7 In the **Resolution of narrow regions** text field, type 1.

Free Tetrahedral I

- 1 In the **Model Builder** window, click **Free Tetrahedral I**.
- 2 In the **Settings** window for **Free Tetrahedral**, locate the **Domain Selection** section.
- 3 From the **Geometric entity level** list, choose **Domain**.
- 4 Select Domain 2 only.
- 5 Click  **Build Selected**.

Boundary Layers I

- 1 In the **Mesh** toolbar, click  **Boundary Layers**.
- 2 In the **Settings** window for **Boundary Layers**, locate the **Geometric Entity Selection** section.
- 3 From the **Geometric entity level** list, choose **Domain**.
- 4 Select Domain 2 only.
- 5 Click to expand the **Corner Settings** section. From the **Handling of sharp edges** list, choose **Trimming**.
- 6 Click to expand the **Transition** section. Clear the **Smooth transition to interior mesh** checkbox.

Boundary Layer Properties

- 1 In the **Model Builder** window, click **Boundary Layer Properties**.
- 2 In the **Settings** window for **Boundary Layer Properties**, locate the **Boundary Selection** section.
- 3 From the **Selection** list, choose **Walls (boundary layer mesh)**.
- 4 Locate the **Layers** section. In the **Number of layers** text field, type 5.
- 5 From the **Thickness specification** list, choose **First layer**.
- 6 In the **Thickness** text field, type $0.15 \cdot d_{\text{visc}}$.

Swept I

- 1 In the **Mesh** toolbar, click  **Swept**.

- 2 In the **Model Builder** window, right-click **Mesh 1** and choose **Build All**.
The mesh should look like the image below.

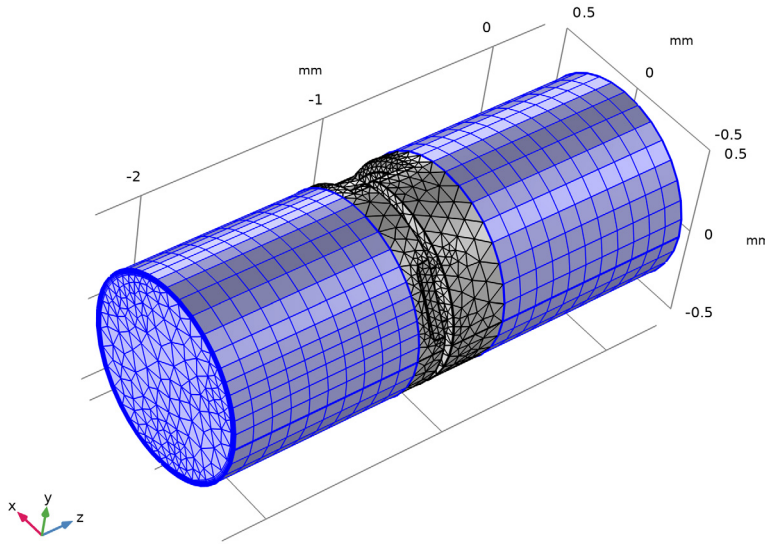

STUDY 1

Step 1: Frequency Domain

- 1 In the **Model Builder** window, under **Study 1** click **Step 1: Frequency Domain**.
- 2 In the **Settings** window for **Frequency Domain**, locate the **Study Settings** section.
- 3 Click  **Range**.
- 4 In the **Range** dialog, choose **ISO preferred frequencies** from the **Entry method** list.
- 5 In the **Start frequency** text field, type 100.
- 6 In the **Stop frequency** text field, type 10000.
- 7 From the **Interval** list, choose **1/3 octave**.
- 8 Click **Replace**.

Add a parametric sweep over the port parameter PortName in order to compute the full scattering and transfer matrix (port 1 and 2).

Parametric Sweep

- 1 In the **Study** toolbar, click  **Parametric Sweep**.

- 2 In the **Settings** window for **Parametric Sweep**, locate the **Study Settings** section.
- 3 Click  **Add**.
- 4 In the table, enter the following settings:

Parameter name	Parameter value list	Parameter unit
PortName (Port name)	1 2	

Now generate the default solver, expand the solver nodes, and select one of the automatically generated iterative solver suggestions. For this model size the iterative option using domain decomposition (DD) is a good choice. If the model gets larger this solver will continue to scale and perform well.

Solution 1 (sol1)

- 1 In the **Study** toolbar, click  **Show Default Solver**.
- 2 In the **Model Builder** window, expand the **Solution 1 (sol1)** node.
- 3 In the **Model Builder** window, expand the **Study 1 > Solver Configurations > Solution 1 (sol1) > Stationary Solver 1** node.
- 4 Right-click **Study 1 > Solver Configurations > Solution 1 (sol1) > Stationary Solver 1 > Suggested Iterative Solver (GMRES with DD) (ta)** and choose **Enable**.

The model requires about 17 GB of RAM to solve.

- 5 In the **Study** toolbar, click  **Compute**.

RESULTS

Start by inspecting the default plots of the acoustic pressure, velocity, and temperature. You can change the frequency studied or the port used to excite the system.

Multislice

- 1 In the **Model Builder** window, expand the **Acoustic Pressure (ta)** node, then click **Multislice**.
- 2 In the **Settings** window for **Multislice**, locate the **Coloring and Style** section.
- 3 From the **Scale** list, choose **Linear**.
- 4 In the **Acoustic Pressure (ta)** toolbar, click  **Plot**.

The image should look like [Figure 4](#).

Acoustic Velocity (ta)

- 1 In the **Model Builder** window, under **Results** click **Acoustic Velocity (ta)**.
- 2 In the **Settings** window for **3D Plot Group**, locate the **Data** section.

3 From the **Parameter value (freq (Hz))** list, choose **1000**.

4 In the **Acoustic Velocity (ta)** toolbar, click  **Plot**.

The image should look like [Figure 5](#).

Temperature Variation (ta)

1 In the **Model Builder** window, click **Temperature Variation (ta)**.

2 In the **Settings** window for **3D Plot Group**, locate the **Data** section.

3 From the **Parameter value (freq (Hz))** list, choose **1000**.

4 In the **Temperature Variation (ta)** toolbar, click  **Plot**.

The image should look like [Figure 6](#).

Full System T-matrix

1 In the **Model Builder** window, right-click **Results** and choose **Node Group**.

2 In the **Settings** window for **Group**, type Full System T-matrix in the **Label** text field.

Full System T11

1 In the **Results** toolbar, click  **ID Plot Group**.

2 In the **Settings** window for **ID Plot Group**, type Full System T11 in the **Label** text field.

Global 1

1 Right-click **Full System T11** and choose **Global**.

2 In the **Settings** window for **Global**, locate the **y-Axis Data** section.

3 In the table, enter the following settings:

Expression	Unit	Description
real(ta.T11)	1	real(T11)
imag(ta.T11)	1	imag(T11)

4 Click the  **y-Axis Log Scale** button in the **Graphics** toolbar.

5 Click the  **x-Axis Log Scale** button in the **Graphics** toolbar.

6 In the **Full System T11** toolbar, click  **Plot**.

Now, duplicate the plot and edit it, in order to depict the other three components of the transfer matrix of the system.

Full System T12

1 In the **Model Builder** window, right-click **Full System T11** and choose **Duplicate**.

2 In the **Settings** window for **ID Plot Group**, type Full System T12 in the **Label** text field.

Global 1

- 1 In the **Model Builder** window, expand the **Full System T12** node, then click **Global 1**.
- 2 In the **Settings** window for **Global**, locate the **y-Axis Data** section.
- 3 In the table, enter the following settings:

Expression	Unit	Description
real(ta.T12)	kg/(m ⁴ *s)	real(T12)
imag(ta.T12)	kg/(m ⁴ *s)	imag(T12)

- 4 In the **Full System T12** toolbar, click  **Plot**.

Full System T21

- 1 In the **Model Builder** window, right-click **Full System T12** and choose **Duplicate**.
- 2 In the **Settings** window for **ID Plot Group**, type Full System T21 in the **Label** text field.

Global 1

- 1 In the **Model Builder** window, expand the **Full System T21** node, then click **Global 1**.
- 2 In the **Settings** window for **Global**, locate the **y-Axis Data** section.
- 3 In the table, enter the following settings:

Expression	Unit	Description
real(ta.T21)	m ⁴ *s/kg	real(T21)
imag(ta.T21)	m ⁴ *s/kg	imag(T21)

- 4 In the **Full System T21** toolbar, click  **Plot**.

Full System T22

- 1 In the **Model Builder** window, right-click **Full System T21** and choose **Duplicate**.
- 2 In the **Settings** window for **ID Plot Group**, type Full System T22 in the **Label** text field.

Global 1

- 1 In the **Model Builder** window, expand the **Full System T22** node, then click **Global 1**.
- 2 In the **Settings** window for **Global**, locate the **y-Axis Data** section.
- 3 In the table, enter the following settings:

Expression	Unit	Description
real(ta.T22)	1	real(T22)
imag(ta.T22)	1	imag(T22)

4 In the **Full System T22** toolbar, click  **Plot**.

The four graphs are depicted in [Figure 7](#).

Proceed and set up the matrix variables necessary to compute and postprocess the transfer matrix of the wax guard subsystem. Also define matrix variables necessary to compute the response of the wax guard when placed in a typical measurement setup (using a lumped approach). The steps are explained in the main model documentation. This also involves initially defining several interpolation functions to import the transfer matrix components of the transducer, coupler, and microphone impedance, as well as the measurement results.

GLOBAL DEFINITIONS

Interpolation: Receiver T-matrix

1 In the **Home** toolbar, click  **Functions** and choose **Global > Interpolation**.

2 In the **Settings** window for **Interpolation**, type **Interpolation: Receiver T-matrix** in the **Label** text field.

3 Locate the **Definition** section. From the **Data source** list, choose **File**.

4 Click  **Browse**.

5 Browse to the model's Application Libraries folder and double-click the file `wax_guard_acoustics_T_receiver.csv`.

6 Locate the **Data Column Settings** section. In the table, enter the following settings:

Columns	Type	Settings
Column 2	Function values	Function name=intIa
Column 3	Function values	Function name=intIb
Column 5	Function values	Function name=intIc
Column 6	Function values	Function name=intId
Column 7	Function values	Function name=intIe
Column 8	Function values	Function name=intIf
Column 9	Function values	Function name=intIg

7 In the table, click to select the cell at row number 1 and column number 1.

8 In the **Unit** text field, type **Hz**.



9 In the table, click to select the cell at row number 2 and column number 2.

10 In the **Name** text field, type `Trec11_real`.

11 In the **Unit** text field, type **1**.

- 12 In the table, click to select the cell at row number 3 and column number 2.
- 13 In the **Name** text field, type Trec11_imag.
- 14 In the **Unit** text field, type 1.
- 15 In the table, click to select the cell at row number 4 and column number 2.
- 16 In the **Name** text field, type Trec12_real.
- 17 In the **Unit** text field, type 1.
- 18 In the table, click to select the cell at row number 5 and column number 2.
- 19 In the **Name** text field, type Trec12_imag.
- 20 In the **Unit** text field, type 1.
- 21 In the table, click to select the cell at row number 6 and column number 2.
- 22 In the **Name** text field, type Trec21_real.
- 23 In the **Unit** text field, type 1.
- 24 In the table, click to select the cell at row number 7 and column number 2.
- 25 In the **Name** text field, type Trec21_imag.
- 26 In the **Unit** text field, type 1.
- 27 In the table, click to select the cell at row number 8 and column number 2.
- 28 In the **Name** text field, type Trec22_real.
- 29 In the **Unit** text field, type 1.
- 30 In the table, click to select the cell at row number 9 and column number 2.
- 31 In the **Name** text field, type Trec22_imag.
- 32 In the **Unit** text field, type 1.
- 33 Locate the **Definition** section. Click  **Import**.

Interpolation: Coupler T-matrix

- 1 In the **Home** toolbar, click  **Functions** and choose **Global > Interpolation**.
- 2 In the **Settings** window for **Interpolation**, type Interpolation: Coupler T-matrix in the **Label** text field.
- 3 Locate the **Definition** section. From the **Data source** list, choose **File**.
- 4 Click  **Browse**.
- 5 Browse to the model's Application Libraries folder and double-click the file wax_guard_acoustics_T_coupler.csv.

6 Locate the **Data Column Settings** section. In the table, enter the following settings:

Columns	Type	Settings
Column 2	Function values	Function name=int2a
Column 3	Function values	Function name=int2b
Column 5	Function values	Function name=int2c
Column 6	Function values	Function name=int2d
Column 7	Function values	Function name=int2e
Column 8	Function values	Function name=int2f
Column 9	Function values	Function name=int2g

7 In the table, click to select the cell at row number 1 and column number 1.

8 In the **Unit** text field, type Hz.

9 In the table, click to select the cell at row number 2 and column number 2.

10 In the **Name** text field, type Top11_real.

11 In the **Unit** text field, type 1.

12 In the table, click to select the cell at row number 3 and column number 2.

13 In the **Name** text field, type Top11_imag.

14 In the **Unit** text field, type 1.

15 In the table, click to select the cell at row number 4 and column number 2.

16 In the **Name** text field, type Top12_real.

17 In the **Unit** text field, type 1.

18 In the table, click to select the cell at row number 5 and column number 2.

19 In the **Name** text field, type Top12_imag.

20 In the **Unit** text field, type 1.

21 In the table, click to select the cell at row number 6 and column number 2.

22 In the **Name** text field, type Top21_real.

23 In the **Unit** text field, type 1.

24 In the table, click to select the cell at row number 7 and column number 2.

25 In the **Name** text field, type Top21_imag.



26 In the **Unit** text field, type 1.

27 In the table, click to select the cell at row number 8 and column number 2.

28 In the **Name** text field, type Top22_real.

- 29 In the **Unit** text field, type 1.
- 30 In the table, click to select the cell at row number 9 and column number 2.
- 31 In the **Name** text field, type Top22_imag.
- 32 In the **Unit** text field, type 1.
- 33 Locate the **Definition** section. Click  **Import**.



Interpolation: Microphone Impedance

- 1 In the **Home** toolbar, click  **Functions** and choose **Global > Interpolation**.
- 2 In the **Settings** window for **Interpolation**, type Interpolation: Microphone Impedance in the **Label** text field.
- 3 Locate the **Definition** section. From the **Data source** list, choose **File**.
- 4 Click  **Browse**.
- 5 Browse to the model's Application Libraries folder and double-click the file wax_guard_acoustics_mic_impedance.csv.
- 6 Locate the **Data Column Settings** section. In the table, click to select the cell at row number 1 and column number 1.
- 7 In the **Unit** text field, type Hz.
- 8 In the table, enter the following settings:

Columns	Type	Settings
Column 2	Function values	Function name=Zmic_real

- 9 In the **Name** text field, type Zmic_real.
- 10 In the **Unit** text field, type 1.
- 11 In the table, click to select the cell at row number 3 and column number 1.
- 12 In the **Name** text field, type Zmic_imag.
- 13 In the **Unit** text field, type 1.
- 14 Locate the **Definition** section. Click  **Import**.

Interpolation: Measurements

- 1 In the **Home** toolbar, click  **Functions** and choose **Global > Interpolation**.
- 2 In the **Settings** window for **Interpolation**, type Interpolation: Measurements in the **Label** text field.
- 3 Locate the **Definition** section. From the **Data source** list, choose **File**.
- 4 Click  **Browse**.

5 Browse to the model's Application Libraries folder and double-click the file `wax_guard_acoustics_measurements.csv`.

6 Locate the **Data Column Settings** section. In the table, enter the following settings:

Columns	Type	Settings
Column 2	Function values	Function name=int4a
Column 3	Function values	Function name=int4b
Column 4	Ignored column	

7 In the table, click to select the cell at row number 1 and column number 1.

8 In the **Unit** text field, type Hz.

9 In the table, click to select the cell at row number 2 and column number 1.

10 In the **Name** text field, type `pWGon_real`.

11 In the **Unit** text field, type Pa.

12 In the table, click to select the cell at row number 3 and column number 1.

13 In the **Name** text field, type `pWGon_imag`.

14 In the **Unit** text field, type Pa.

15 Locate the **Definition** section. Click  **Import**.

In order to use the matrix variables turn on the show variables utilities (if not already selected). Click the small eye at the top of the Model Builder tree.

16 Click the  **Show More Options** button in the **Model Builder** toolbar.

17 In the **Show More Options** dialog, in the tree, select the checkbox for the node **General > Variable Utilities**.

18 Click **OK**.

Matrix Inverse: Inlet Tube

1 In the **Home** toolbar, click  **Variable Utilities** and choose **Global > Matrix Inverse**.

2 In the **Settings** window for **Matrix Inverse**, type Matrix Inverse: Inlet Tube in the **Label** text field.

3 Locate the **Input Matrix** section. From the **Matrix size** list, choose **2X2**.

4 In the table, enter the following settings:

$\cos(kc_{in}L_{in})$	$-Zc_{in}/(iS_{in})\sin(kc_{in}L_{in})$
$iS_{in}/Zc_{in}\sin(kc_{in}L_{in})$	$\cos(kc_{in}L_{in})$

Matrix: Wax Guard (model)

- 1 In the **Home** toolbar, click  **Variable Utilities** and choose **Global > Matrix**.
- 2 In the **Settings** window for **Matrix**, type Matrix: Wax Guard (model) in the **Label** text field.
- 3 In the **Name** text field, type Twg.
- 4 Locate the **Input Matrix** section. From the **Matrix size** list, choose **2X2**.
The expression entered is the matrix product of the inverse of the inlet tube T-matrix and the total system matrix.
- 5 In the table, enter the following settings:

$\text{matinv1.inVT11*comp1.ta.T11+}$ $\text{matinv1.inVT12*comp1.ta.T21}$	$\text{matinv1.inVT11*comp1.ta.T12+}$ $\text{matinv1.inVT12*comp1.ta.T22}$
$\text{matinv1.inVT21*comp1.ta.T11+}$ $\text{matinv1.inVT22*comp1.ta.T21}$	$\text{matinv1.inVT21*comp1.ta.T12+}$ $\text{matinv1.inVT22*comp1.ta.T22}$

Matrix: Receiver

- 1 In the **Home** toolbar, click  **Variable Utilities** and choose **Global > Matrix**.
- 2 In the **Settings** window for **Matrix**, type Matrix: Receiver in the **Label** text field.
- 3 In the **Name** text field, type Trec.
- 4 Locate the **Input Matrix** section. From the **Matrix size** list, choose **2X2**.
- 5 In the table, enter the following settings:

$\text{Trec11_real(freq)+i*}$ Trec11_imag(freq)	$\text{Trec12_real(freq)+i*}$ Trec12_imag(freq)
$\text{Trec21_real(freq)+i*}$ Trec21_imag(freq)	$\text{Trec22_real(freq)+i*}$ Trec22_imag(freq)

Matrix: Receiver Tube

- 1 In the **Home** toolbar, click  **Variable Utilities** and choose **Global > Matrix**.
- 2 In the **Settings** window for **Matrix**, type Matrix: Receiver Tube in the **Label** text field.
- 3 In the **Name** text field, type Trt.
- 4 Locate the **Input Matrix** section. From the **Matrix size** list, choose **2X2**.
- 5 In the table, enter the following settings:

cos(kc_rt*L_rt)	$\text{-Zc_rt/(i*S_rt)*sin(kc_rt*L_rt)}$
$\text{i*S_rt/Zc_rt*sin(kc_rt*L_rt)}$	cos(kc_rt*L_rt)

Matrix: Coupler

- 1 In the **Home** toolbar, click  **Variable Utilities** and choose **Global > Matrix**.
- 2 In the **Settings** window for **Matrix**, type Matrix: Coupler in the **Label** text field.
- 3 In the **Name** text field, type Top.
- 4 Locate the **Input Matrix** section. From the **Matrix size** list, choose **2X2**.
- 5 In the table, enter the following settings:

Tcp11_real(freq)+i*	Tcp12_real(freq)+i*
Tcp11_imag(freq)	Tcp12_imag(freq)
Tcp21_real(freq)+i*	Tcp22_real(freq)+i*
Tcp21_imag(freq)	Tcp22_imag(freq)

Group: Matrix Products

- 1 In the **Model Builder** window, right-click **Global Definitions** and choose **Node Group**.
- 2 In the **Settings** window for **Group**, type Group: Matrix Products in the **Label** text field.

Matrix 5 (T5)

- 1 In the **Home** toolbar, click  **Variable Utilities** and choose **Global > Matrix**.
- 2 In the **Settings** window for **Matrix**, locate the **Input Matrix** section.
- 3 From the **Matrix size** list, choose **2X2**.
- 4 In the table, enter the following settings:

Trec11*Trt11+Trec12*Trt21	Trec11*Trt12+Trec12*Trt22
Trec21*Trt11+Trec22*Trt21	Trec21*Trt12+Trec22*Trt22

Matrix 6 (T6)

- 1 In the **Home** toolbar, click  **Variable Utilities** and choose **Global > Matrix**.
- 2 In the **Settings** window for **Matrix**, locate the **Input Matrix** section.
- 3 From the **Matrix size** list, choose **2X2**.
- 4 In the table, enter the following settings:

T511*Twg11+T512*Twg21	T511*Twg12+T512*Twg22
T521*Twg11+T522*Twg21	T521*Twg12+T522*Twg22

Matrix 7 (T7)

- 1 In the **Home** toolbar, click  **Variable Utilities** and choose **Global > Matrix**.
- 2 In the **Settings** window for **Matrix**, locate the **Input Matrix** section.
- 3 From the **Matrix size** list, choose **2X2**.

4 In the table, enter the following settings:

$T611*Tcp11+T612*Tcp21$	$T611*Tcp12+T612*Tcp22$
$T621*Tcp11+T622*Tcp21$	$T621*Tcp12+T622*Tcp22$

All the necessary matrix variables have now been created. In order to use them in postprocessing update the solution (it is not necessary to re-solve the model).

STUDY I

In the **Study** toolbar, click  **Update Solution**.

RESULTS

Wax Guard T-matrix

- 1 In the **Model Builder** window, right-click **Full System T-matrix** and choose **Duplicate**.
- 2 In the **Settings** window for **Group**, type Wax Guard T-matrix in the **Label** text field.

Wax Guard T11

- 1 In the **Model Builder** window, expand the **Wax Guard T-matrix** node, then click **Full System T11**.
- 2 In the **Settings** window for **ID Plot Group**, type Wax Guard T11 in the **Label** text field.

Global I

- 1 In the **Model Builder** window, expand the **Wax Guard T11** node, then click **Global I**.
- 2 In the **Settings** window for **Global**, locate the **y-Axis Data** section.
- 3 In the table, enter the following settings:

Expression	Unit	Description
$\text{real}(T_{wg11})$		$\text{real}(T_{11})$
$\text{imag}(T_{wg11})$		$\text{imag}(T_{11})$

- 4 In the **Wax Guard T11** toolbar, click  **Plot**.

Wax Guard T12

- 1 In the **Model Builder** window, under **Results > Wax Guard T-matrix** click **Full System T12**.
- 2 In the **Settings** window for **ID Plot Group**, type Wax Guard T12 in the **Label** text field.

Global I

- 1 In the **Model Builder** window, expand the **Wax Guard T12** node, then click **Global I**.
- 2 In the **Settings** window for **Global**, locate the **y-Axis Data** section.

3 In the table, enter the following settings:

Expression	Unit	Description
real (T _{wg12})		real (T ₁₂)
imag (T _{wg12})		imag (T ₁₂)

4 In the **Wax Guard T12** toolbar, click  **Plot**.

Wax Guard T21

1 In the **Model Builder** window, under **Results > Wax Guard T-matrix** click **Full System T21.1**.

2 In the **Settings** window for **ID Plot Group**, type Wax Guard T21 in the **Label** text field.

Global 1

1 In the **Model Builder** window, expand the **Wax Guard T21** node, then click **Global 1**.

2 In the **Settings** window for **Global**, locate the **y-Axis Data** section.

3 In the table, enter the following settings:

Expression	Unit	Description
real (T _{wg21})		real (T ₂₁)
imag (T _{wg21})		imag (T ₂₁)

4 In the **Wax Guard T21** toolbar, click  **Plot**.

Wax Guard T22

1 In the **Model Builder** window, under **Results > Wax Guard T-matrix** click **Full System T22.1**.

2 In the **Settings** window for **ID Plot Group**, type Wax Guard T22 in the **Label** text field.

Global 1

1 In the **Model Builder** window, expand the **Wax Guard T22** node, then click **Global 1**.

2 In the **Settings** window for **Global**, locate the **y-Axis Data** section.

3 In the table, enter the following settings:

Expression	Unit	Description
real (T _{wg22})		real (T ₂₂)
imag (T _{wg22})		imag (T ₂₂)

4 In the **Wax Guard T22** toolbar, click  **Plot**.

The four graphs are depicted in [Figure 8](#).

Mesh

1 In the **Results** toolbar, click  **3D Plot Group**.

2 In the **Settings** window for **3D Plot Group**, type Mesh in the **Label** text field.

Mesh 1

1 Right-click **Mesh** and choose **Mesh**.

2 In the **Settings** window for **Mesh**, locate the **Level** section.

3 From the **Level** list, choose **Volume**.

4 Click to expand the **Element Filter** section. Select the **Enable filter** checkbox.

5 In the **Expression** text field, type $x > 0$.

6 In the **Mesh** toolbar, click  **Plot**.

This plot makes it possible to inspect the inside of the mesh. It should look like the image below.

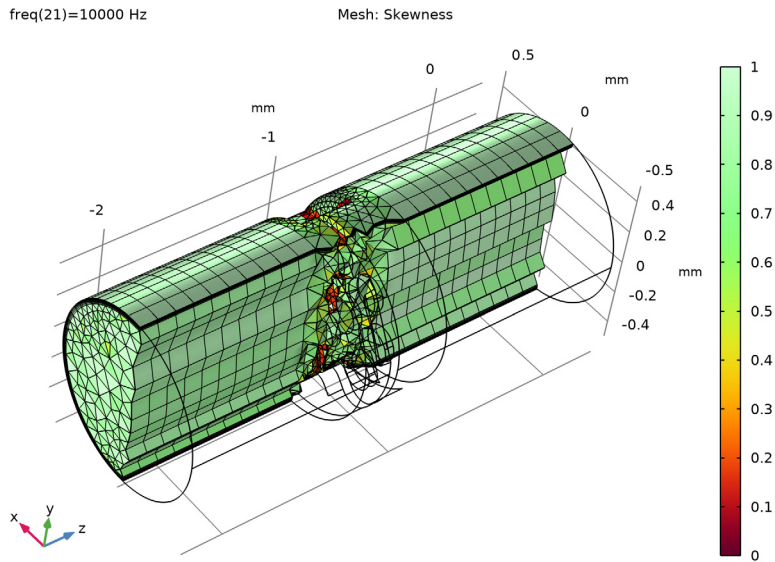

Full System Response

1 In the **Results** toolbar, click  **ID Plot Group**.

2 In the **Settings** window for **ID Plot Group**, type Full System Response in the **Label** text field.

3 Click to expand the **Title** section. From the **Title type** list, choose **Label**.

4 Locate the **Plot Settings** section.

- 5 Select the **y-axis label** checkbox. In the associated text field, type Microphone (dB SPL).
- 6 Locate the **Axis** section. Select the **x-axis log scale** checkbox.
- 7 Locate the **Legend** section. From the **Position** list, choose **Upper left**.

Global 1

- 1 Right-click **Full System Response** and choose **Global**.
- 2 In the **Settings** window for **Global**, locate the **y-Axis Data** section.
- 3 In the table, enter the following settings:

Expression	Unit	Description
$20 \cdot \log_{10}(\text{abs}(\text{pWGon_real}(\text{freq}) + i \cdot \text{pWGon_imag}(\text{freq}))/20e-6)$		Measurements
$20 \cdot \log_{10}(\text{abs}(V_{\text{rec}} / (T_{711} + T_{712} / Z_{\text{mic}})) / 20e-6)$		Transfer matrix (model)

- 4 In the **Full System Response** toolbar, click  **Plot**.

This plot shows the response of the wax guard when placed in a typical measurement setup. The results should look like [Figure 9](#).

Next create an evaluation group and evaluate the wax guard transfer matrix components (real and imaginary parts). This will create a table that can be used to export the data into a text file for further use.

Evaluation Group: Wax Guard, T-Matrix (real/imag)

- 1 In the **Results** toolbar, click  **Evaluation Group**.
- 2 In the **Settings** window for **Evaluation Group**, type Evaluation Group: Wax Guard, T-Matrix (real/imag) in the **Label** text field.

Global Evaluation 1

- 1 Right-click **Evaluation Group: Wax Guard, T-Matrix (real/imag)** and choose **Global Evaluation**.
- 2 In the **Settings** window for **Global Evaluation**, locate the **Data** section.
- 3 From the **Dataset** list, choose **Study 1/Solution 1 (sol1)**.
- 4 Locate the **Expressions** section. In the table, enter the following settings:

Expression	Unit	Description
real(Twg11)		
imag(Twg11)		

Expression	Unit	Description
real(Twg12)		
imag(Twg12)		
real(Twg21)		
imag(Twg21)		
real(Twg22)		
imag(Twg22)		

5 In the **Evaluation Group: Wax Guard, T-Matrix (real/imag)** toolbar, click  **Evaluate**.

Finally, create the image that is used as the model thumbnail. This step can be skipped.

Thumbnail

- 1** In the **Results** toolbar, click  **3D Plot Group**.
- 2** In the **Settings** window for **3D Plot Group**, type Thumbnail in the **Label** text field.
- 3** Click to expand the **Title** section. From the **Title type** list, choose **None**.
- 4** Locate the **Plot Settings** section. Clear the **Plot dataset edges** checkbox.

Slice 1

- 1** Right-click **Thumbnail** and choose **Slice**.
- 2** In the **Settings** window for **Slice**, locate the **Expression** section.
- 3** In the **Expression** text field, type `ta.v_rms`.
- 4** From the **Unit** list, choose **mm/s**.
- 5** Locate the **Plane Data** section. In the **Planes** text field, type 1.

Surface 1

- 1** In the **Model Builder** window, right-click **Thumbnail** and choose **Surface**.
- 2** In the **Settings** window for **Surface**, locate the **Expression** section.
- 3** In the **Expression** text field, type 1.
- 4** Locate the **Coloring and Style** section. From the **Coloring** list, choose **Uniform**.
- 5** From the **Color** list, choose **Gray**.

Selection 1

- 1** Right-click **Surface 1** and choose **Selection**.
- 2** In the **Settings** window for **Selection**, locate the **Selection** section.
- 3** Click  **Paste Selection**.
- 4** In the **Paste Selection** dialog, type 7-10, 15-54 in the **Selection** text field.

5 Click **OK**.



Line 1

- 1 In the **Model Builder** window, right-click **Thumbnail** and choose **Line**.
- 2 In the **Settings** window for **Line**, locate the **Expression** section.
- 3 In the **Expression** text field, type 1.
- 4 Locate the **Coloring and Style** section. From the **Coloring** list, choose **Uniform**.
- 5 From the **Color** list, choose **Black**.

Selection 1

- 1 Right-click **Line 1** and choose **Selection**.
- 2 In the **Settings** window for **Selection**, locate the **Selection** section.
- 3 Click  **Paste Selection**.
- 4 In the **Paste Selection** dialog, type 7, 8, 10, 11, 13, 14, 17, 19, 31, 32, 34, 36, 42, 43, 89-92, 94, 96, 103, 104, 137-140 in the **Selection** text field.
- 5 Click **OK**.

Thumbnail

- 1 In the **Model Builder** window, under **Results** click **Thumbnail**.
- 2 In the **Settings** window for **3D Plot Group**, locate the **Data** section.
- 3 From the **Parameter value (freq (Hz))** list, choose **1000**.
- 4 Locate the **Color Legend** section. Select the **Show units** checkbox.
- 5 Select the **Show maximum and minimum values** checkbox.
- 6 In the **Graphics** window toolbar, click  next to  **Scene Light**, then choose **Ambient Occlusion**.

7 In the **Thumbnail** toolbar, click  **Plot**.

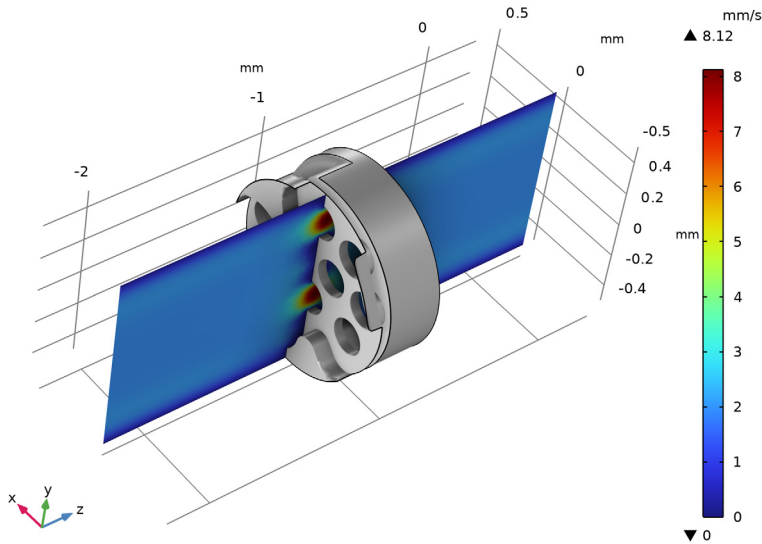

Detailed Geometry Instructions



If you want to create the geometry yourself, follow these steps.



GEOMETRY 1

Check to see if your **Geometry representation** setting is set to the CAD kernel. This is required to import the model geometry and requires the CAD Import Module. If the COMSOL kernel is selected proceed with the next step.

- 1 In the **Model Builder** window, under **Component 1 (comp1)** click **Geometry 1**.
- 2 In the **Settings** window for **Geometry**, locate the **Advanced** section.
- 3 From the **Geometry representation** list, choose **CAD kernel**.

Import 1 (imp1)

- 1 In the **Geometry** toolbar, click  **Import**.
- 2 In the **Settings** window for **Import**, locate the **Source** section.
- 3 Click  **Browse**.

- 4 Browse to the model's Application Libraries folder and double-click the file `wax_guard_acoustics_cad_geometry.stp`.
- 5 Click  **null**.
- 6 Locate the **Length Unit** section. From the **Length unit** list, choose **From CAD document**.
- 7 Click  **Build Selected**.

The CAD geometry of the wax guard is depicted in [Figure 2](#). Use the graphics window tools to rotate, move, and zoom. The CAD file is of the device, now create the air domain inside as well as a 1 mm inlet section.

Union 1 (un1)

- 1 In the **Geometry** toolbar, click  **Booleans and Partitions** and choose **Union**.
- 2 Click in the **Graphics** window and then press Ctrl+A to select both objects.
- 3 In the **Settings** window for **Union**, locate the **Union** section.
- 4 From the **Repair tolerance** list, choose **Absolute**.
- 5 In the **Absolute repair tolerance** text field, type 1.0E-4.

If the tolerance is set too low, for example, at 1E-6, the CAD will not union correctly because of tolerances used in production.

- 6 Click  **Build All Objects**.

Cap Faces 1 (cap1)

- 1 In the **Geometry** toolbar, click  **Defeaturing and Repair** and choose **Cap Faces**.

2 On the object **uni1**, select Edges 57 and 58 only.

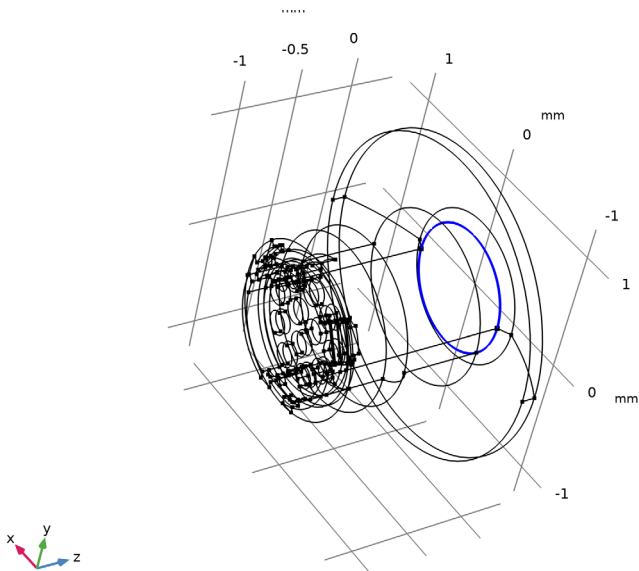

Extrude 1 (ext1)

1 In the **Geometry** toolbar, click  **Extrude**.

2 On the object **cap1**, select Boundary 38 only.

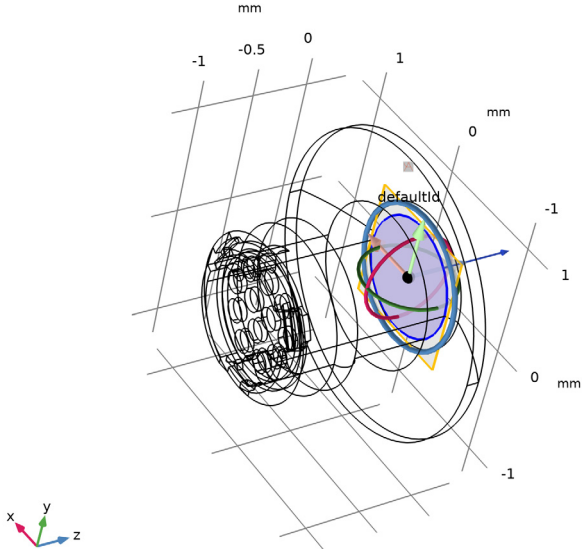

3 In the **Settings** window for **Extrude**, locate the **Distances** section.

4 From the **Specify** list, choose **Vertices to extrude to**.

5 On the object **cap1**, select Point 200 only.

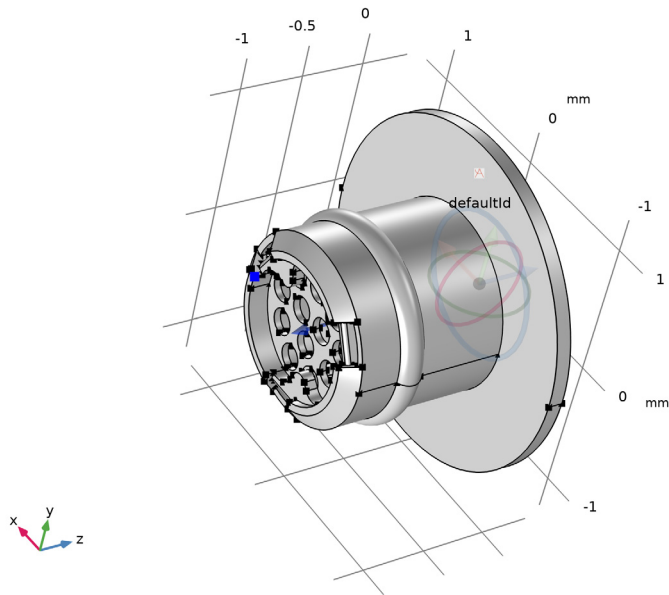

6 Click  **Build Selected**.

Now delete all the domains that do not represent the air inside the system. Do it in two steps, to simplify selecting the domains.

Delete Entities 1 (del1)

1 In the **Model Builder** window, right-click **Geometry 1** and choose **Delete Entities**.

2 In the **Settings** window for **Delete Entities**, locate the **Entities or Objects to Delete** section.

3 From the **Geometric entity level** list, choose **Domain**.

4 On the object **ext1**, select Domain 1 only.

5 Click  **Build Selected**.

Delete Entities 2 (del2)

1 Right-click **Geometry 1** and choose **Delete Entities**.

2 In the **Settings** window for **Delete Entities**, locate the **Entities or Objects to Delete** section.

3 From the **Geometric entity level** list, choose **Domain**.

4 On the object **del1**, select Domains 1 and 3–6 only.

5 Click  **Build Selected.**

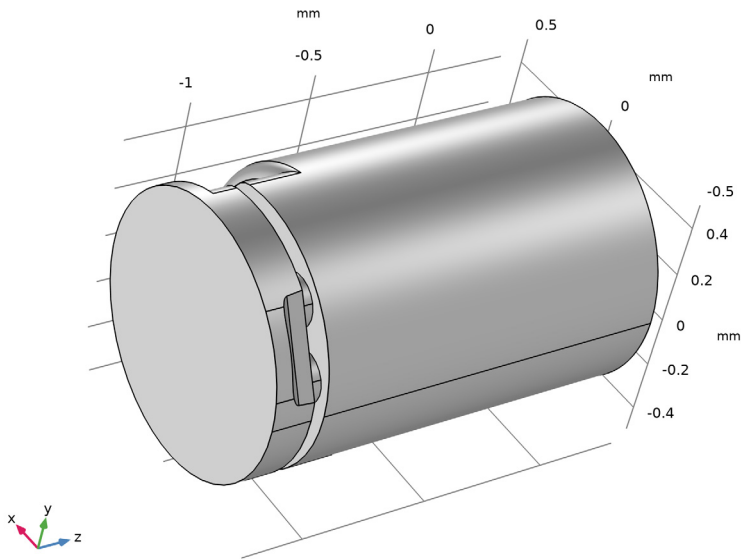

Extrude 2 (ext2)

- 1 In the **Geometry** toolbar, click  **Extrude.**
- 2 On the object **del2**, select Boundary 3 only.
- 3 In the **Settings** window for **Extrude**, locate the **Distances** section.
- 4 In the table, enter the following settings:

Distances (mm)
1 [mm]

The value 1 [mm] should correspond to the parameter L_{in} defined in the model.

5 Click  **Build Selected**.

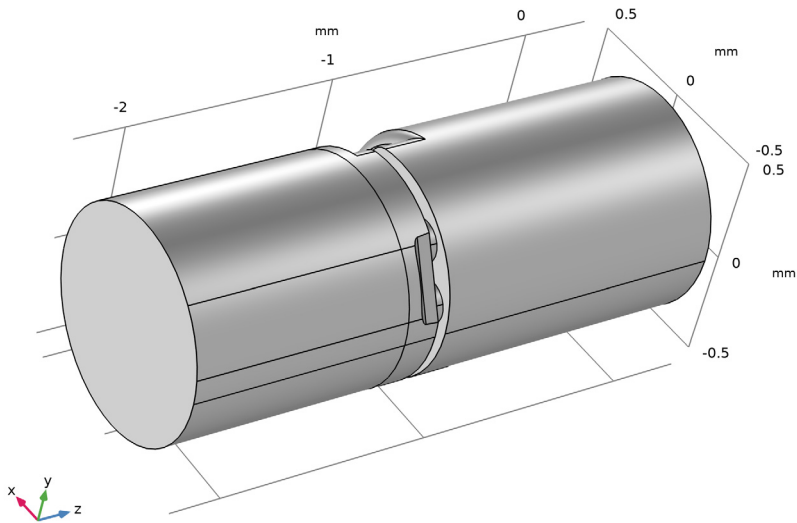

Work Plane 1 (wp1)

- 1 In the **Geometry** toolbar, click  **Work Plane**.
- 2 In the **Settings** window for **Work Plane**, locate the **Plane Definition** section.
- 3 In the **z-coordinate** text field, type `-0.75`.

Partition Domains 1 (pard1)

- 1 In the **Geometry** toolbar, click  **Booleans and Partitions** and choose **Partition Domains**.
- 2 On the object **ext2**, select Domain 2 only.
- 3 In the **Settings** window for **Partition Domains**, click  **Build Selected**.

Form Union (fin)

- 1 In the **Geometry** toolbar, click  **Build All**.

2 In the **Model Builder** window, click **Form Union (fin)**.

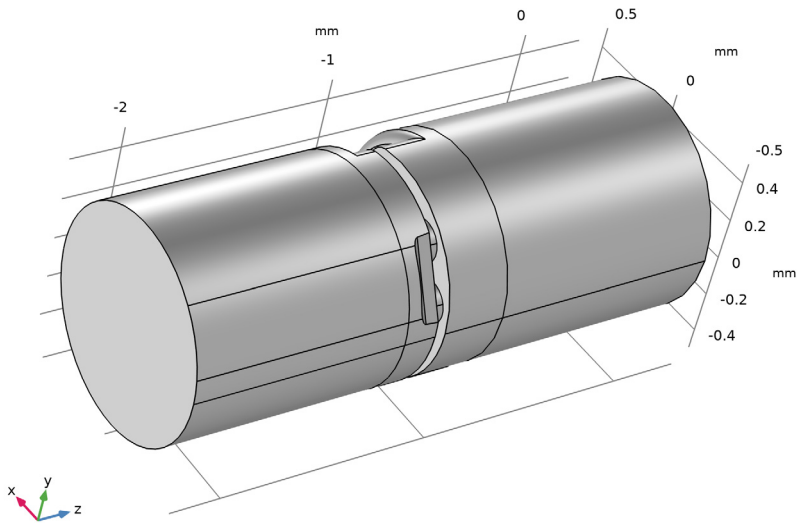

Now, perform some virtual geometry operations to prepare the geometry for modeling.

Form Composite Faces 1 (cmf1)

1 In the **Geometry** toolbar, click  **Virtual Operations** and choose **Form Composite Faces**.

2 On the object **fin**, select Boundaries 35, 39, 45, 47, 64, 65, 69, and 75 only.

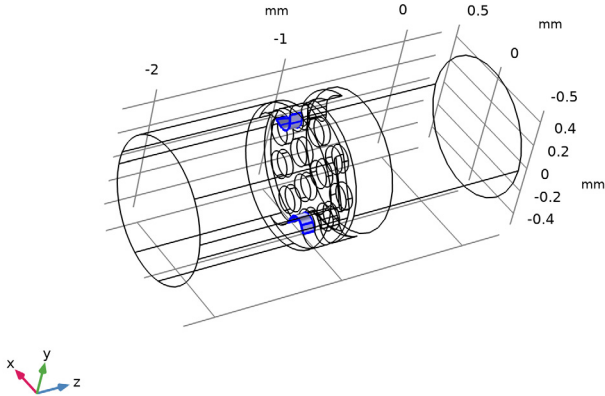

3 In the **Settings** window for **Form Composite Faces**, click  **Build Selected**.

Ignore Edges 1 (ige1)

1 In the **Geometry** toolbar, click  **Virtual Operations** and choose **Ignore Edges**.

2 Click the  **Wireframe Rendering** button in the **Graphics** toolbar.

3 On the object **cmfl**, select Edges 40, 45, 110, 112, 123, 128, 185, and 187 only.

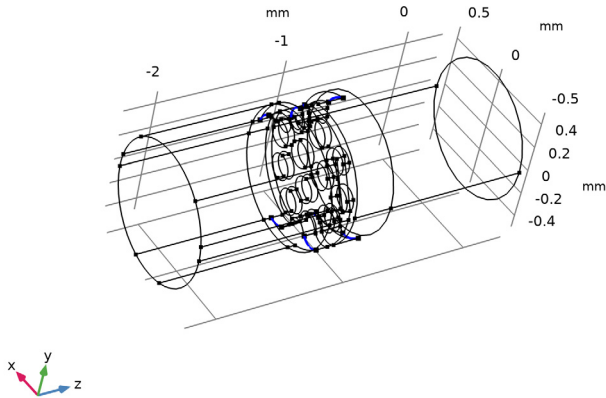

4 Click the  **Zoom Extents** button in the **Graphics** toolbar.

5 In the **Settings** window for **Ignore Edges**, click  **Build Selected**.

Ignore Edges 2 (ige2)

1 In the **Geometry** toolbar, click  **Virtual Operations** and choose **Ignore Edges**.

2 On the object **igel**, select Edges 21, 23, 27, 45, 47, 61, 63, 80, 82, 85, 86, 95, 99, 130-134, 136, 140, 141, 174, 176, 184, and 186 only.

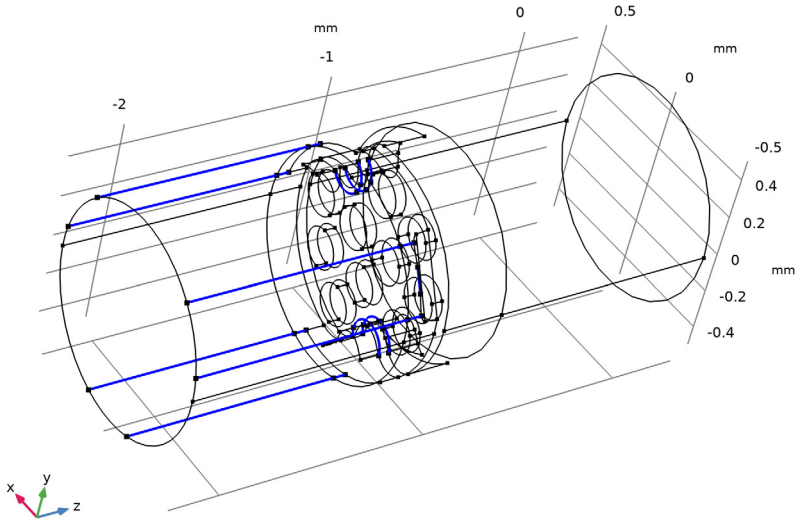

3 In the **Settings** window for **Ignore Edges**, click  **Build Selected**.

4 Click the  **Wireframe Rendering** button in the **Graphics** toolbar.

The finalized geometry should look like the one below.

