



Model created in COMSOL Multiphysics 6.4

# Wave-Based Time-Domain Room Acoustics with Frequency-Dependent Impedance

## Introduction

---

The use of wave-based techniques for room acoustic simulations has spread in the last years due to the increase in computational performance as well as the development of new numerical methods. The challenge of including realistic impedance conditions at walls is traditionally solved in the frequency domain. Recent research has focused on the implementation of frequency-dependent impedance in the time-domain models using partial fraction representation of the frequency-dependent data (see [Ref. 1](#), [Ref. 2](#), [Ref. 3](#)).

This tutorial shows how to get partial fraction representation of frequency-dependent wall impedance data via the *Partial Fraction Fit* function and how to use the results to set up the built-in impedance boundary conditions for room acoustic response simulation in the time domain. The model uses the *Pressure Acoustics, Time Explicit* interface to simulate the propagation of sound. The physics interface is based on the discontinuous Galerkin (dG-FEM) method which uses a matrix free approach and a time explicit solver. The method is very memory efficient and well suited for distributed computing on a cluster architecture.

## Model Definition

---

The model studies the response of a small  $50.5 \text{ m}^3$  room shown in [Figure 1](#) on the left. The loudspeaker to the left of the TV emits an acoustic signal given as a sine wave modulated by a Gaussian envelope at the center frequency  $f_0 = 700 \text{ Hz}$ . As the signal propagates from the speaker, the acoustic pressure is measured at four listening points located equidistantly on a line drawn from the speaker to the sofa, as shown in [Figure 1](#) on the right.

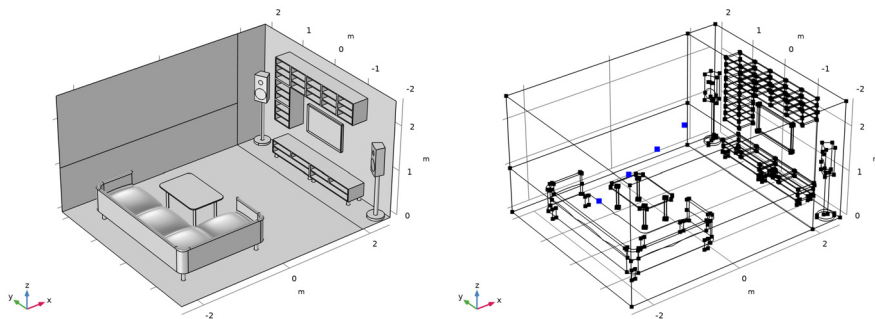

*Figure 1: Room geometry (left) and location of listening points (right).*

The sound absorption properties of the carpet, ceiling, sofa, and walls are modeled using the simplified local reacting approximation which states that the response at a certain point of the surface depends on the sound pressure at that point. This behavior is described by an impedance boundary condition imposed on the surface. When not purely resistive, as, for example, for porous materials, the boundary impedance will depend on the frequency, resulting in the following boundary condition in the frequency domain

$$u_n(\omega) = \frac{p(\omega)}{Z(\omega)} = Y(\omega)p(\omega), \quad (1)$$

where  $Z$  is the frequency-dependent specific impedance and  $Y$  is the admittance. The time-domain equivalent of Equation 1 involves a convolution instead of the multiplication

$$u_n(t) = \int_{-\infty}^t Y(t-\tau)p(\tau)d\tau \quad (2)$$

and thus requires the knowledge of  $Y(t)$  in the time domain and thus the computation of the inverse Fourier (or Laplace) transform, which, obviously, cannot be done analytically for a general  $Y(\omega)$  obtained from various poroacoustic models or measurements. Moreover, it is not enough to know the values of the impedance (admittance) for a number of frequencies or for a frequency range to translate the boundary condition from the frequency to the time domain. Therefore,  $Y(\omega)$  has to be extended to the whole complex plane.

An approximate analytical representation of  $Y(t)$  can be retrieved from a rational approximation of  $Y(\omega)$  that is defined on the whole complex plane:

$$Y(\omega) \approx \frac{a_0 + a_1(i\omega) + \dots + a_N(i\omega)^N}{1 + b_1(i\omega) + \dots + b_N(i\omega)^N} = Y_\infty + \sum_{k=1}^N \frac{A_k}{i\omega - \alpha_k}. \quad (3)$$

Indeed, each fraction term on the right-hand side of Equation 3 corresponds to an exponential decay in the time domain

$$L^{-1}\left(\frac{A_k}{s - \alpha_k}\right) = A_k e^{\alpha_k t} H(t), \quad (4)$$

where  $L^{-1}$  is the inverse Laplace transform and  $H(t)$  is the Heaviside step function.

However, the approximation given by Equation 3 has to fulfill three conditions in order for the time-domain boundary condition to be physical:

- Causality,  $Y(\omega)$  is analytic and nonzero in  $\Im(\omega) > 0$ ;

- Reality,  $\bar{Y}(\omega) = Y(-\omega)$ , that is,  $\Re(Y(\omega))$  is even and  $\Im(Y(\omega))$  is odd;
- Passivity,  $\Re(Y(\omega)) > 0$  for all real  $\omega$ .

The causality and reality conditions are fulfilled if  $Y_\infty$  is real; the residues,  $A_k$ , and poles,  $\alpha_k$ , are either real or come in complex-conjugate pairs; and  $\Re(\alpha_k) < 0$  (for the exponentials in Equation 4 to decay as the time increases). That is

$$Y(\omega) \approx Y_\infty + \sum_{k=1}^{N_R} \frac{R_k}{i\omega - \xi_k} + \frac{1}{2} \sum_{k=1}^{N_C} \left[ \frac{Q_k}{i\omega - \zeta_k} + \frac{\bar{Q}_k}{i\omega - \bar{\zeta}_k} \right], \quad (5)$$

where  $N_R$  and  $N_C$  are the numbers of pure real poles and complex-conjugate pole pairs, respectively.

The form given in Equation 5 is used to reduce the evaluation of the integral in Equation 2 to system of auxiliary ordinary differential equations (ODEs) for memory variables. This approach is referred to as ADE method (see Ref. 1, Ref. 2, Ref. 3). The system of ODEs is automatically created and solved when you set up an *Impedance* boundary condition with a **General local reacting (rational approximation)** option.

## Results and Discussion

---

The real and imaginary parts of the fitted frequency dependent admittance data are depicted in Figure 2. As seen, the sofa surface is more absorptive than the others, especially at the higher frequencies.

Figure 3 shows the acoustic pressure recorded at the listening points in blue, green, red, and cyan colors as the point moves away from the source. The values are normalized to the maximum pressure at the source. As seen from the plot, the pressure magnitude decreases with the time.

The history of the signal propagation through the room is shown in Figure 4. The signal emitted from the loudspeaker reaches listening point 1 at  $t = 4T_0$  ( $T_0 = 1/f_0$ ) and listening point 4 at  $t = 11T_0$ . Then multiple reflections occur while the signal magnitude goes down at  $t = 18T_0$  and  $t = 25T_0$ .

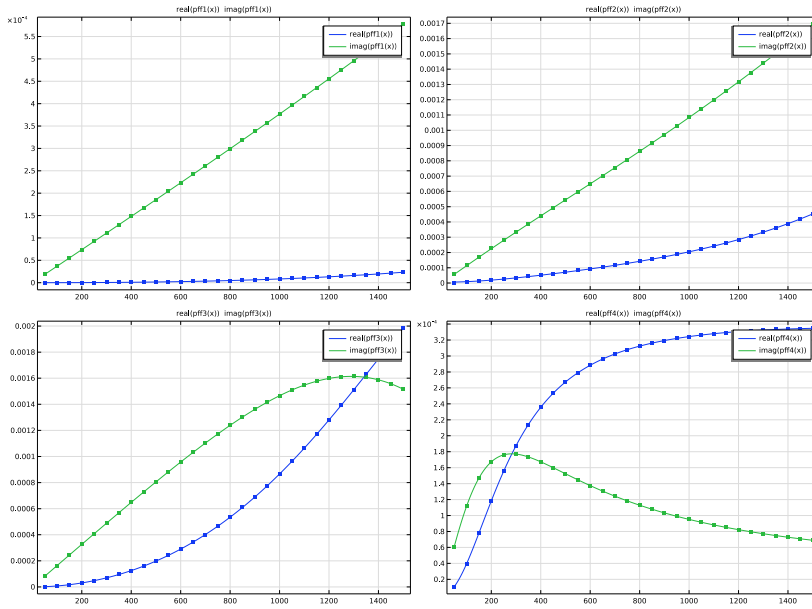

Figure 2: Original admittance data and partial fraction expansions for the carpet, ceiling, sofa, and wall (from the top, left to right).

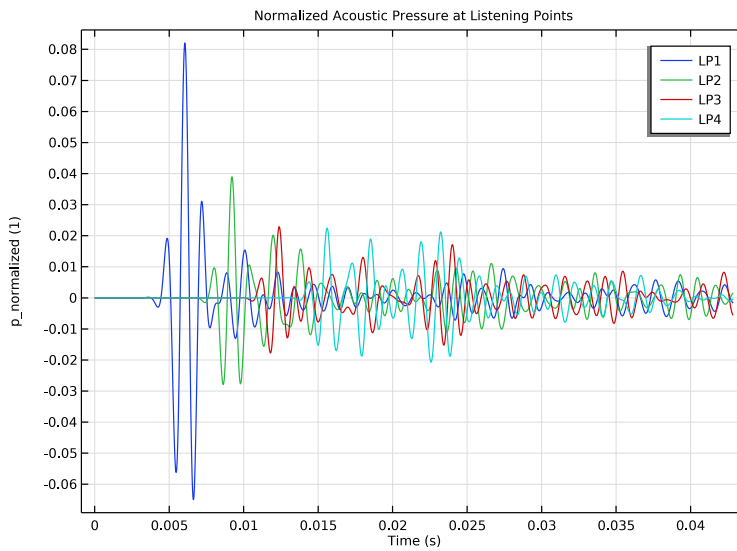

Figure 3: Acoustic pressure at listening points.

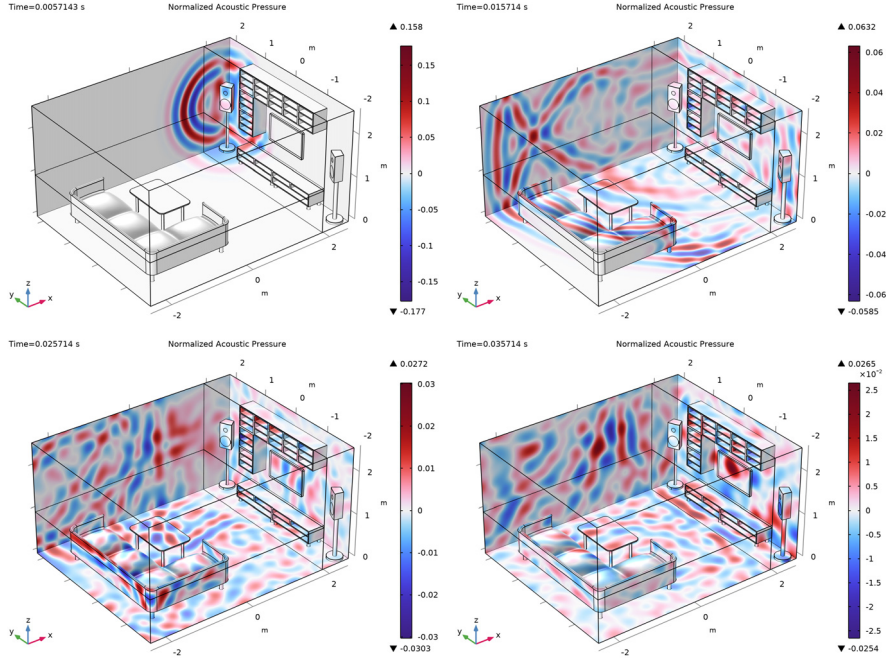

Figure 4: Normalized acoustic pressure at  $t = 4T_0$ ,  $11T_0$ ,  $18T_0$ , and  $25T_0$  (from the top, left to right).

### Notes About the COMSOL Implementation

#### PARTIAL FRACTION FIT OF ADMITTANCE DATA

The partial fraction approximation (expansion) is obtained for the carpet, ceiling, sofa, and walls admittance through the built-in *Partial Fraction Fit* function within the frequency range from 50 Hz to 1.5 kHz. The form given by Equation 5 ensures that the reality condition is fulfilled. This is not always the case for the causality and passivity conditions. However, the *Partial Fraction Fit* function has the necessary tools that can be used to make the result fulfill the causality and reality conditions, thus making the time-domain impedance boundary condition physical.

The *Partial Fraction Fit* function fits the input data within a given tolerance that is found in the **Advanced** section (default  $10^{-3}$ ). A higher tolerance error results in a higher degree,  $N$ , of the polynomials in Equation 3 and therefore a larger number of terms in the expansion Equation 5. The number of poles/residues in the expansion in turns

corresponds to the number of ODEs solved for the memory variables. The default tolerance provides a balance between the approximation accuracy and the number of terms in the expansion, thus the computation costs when the expansion is used in an impedance boundary condition. On the other hand, increasing the tolerance may yield better results.

For example, the first *Partial Fraction Fit* function present in the model fits the admittance of the carpet. The default tolerance results in one real-valued pole and one complex-valued pole pair. From a distance the result looks good, but a closer look reveals that the passivity condition is violated at low frequencies: the real part of  $Y$  becomes negative between 50 and 90 Hz. A tighter tolerance of  $10^{-5}$  yields two extra terms with real-valued poles and a partial fraction expansion that is passive within the given frequency range (see [Figure 5](#)).

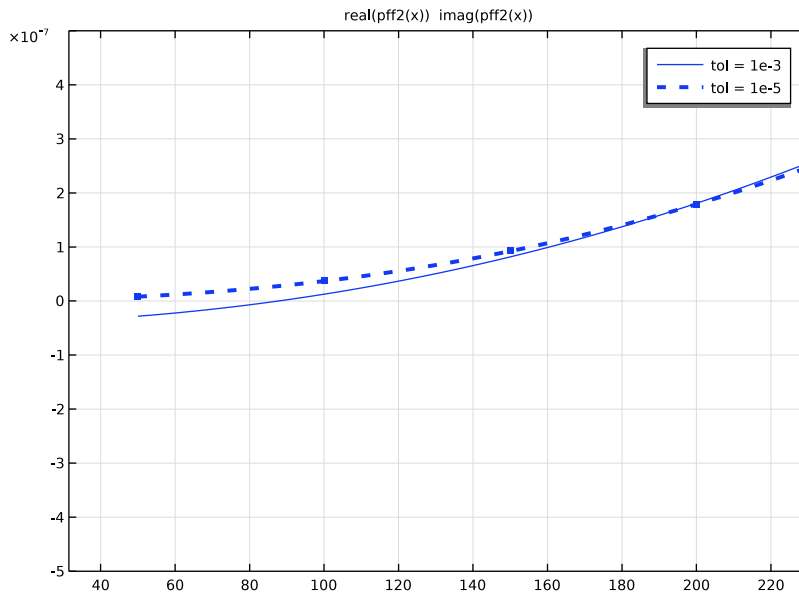

Figure 5: Real part of the carpet admittance fit obtained with tolerance of  $10^{-3}$  and  $10^{-5}$ .

The violation of the causality condition takes place when one or more poles in the partial fraction expansion have positive real part (that is, they are unstable), which can usually happen to the pure real poles. If an unstable pole has a relatively large residue, click the **Flip Poles** button to flip it onto the left half plane and circumvent the issue. The residues will be recomputed and updated automatically. Otherwise, enable the **Automatically detect and remove Froissart doublets** option and run the fit. The poles with relatively small

residues will be removed during the cleanup process. This procedure is carried out when fitting the ceiling admittance data with the second *Partial Fraction Fit* function.

A different situation appears with the third *Partial Fraction Fit* function that is used to build a partial fraction expansion for the sofa admittance. Fitting the data with the default tolerance yields an approximation that fulfills all three conditions. However, the absolute value of the real-valued pole is much larger than that of the complex-valued pole. This results in a stiff ODE, which affects the stability of the time-integration scheme. Indeed, the Pressure Acoustics, Time Explicit physics interface used in this tutorial relies on explicit time-integration schemes. The time step is deduced solely from the minimum mesh element size (see the section below) and the speed of sound, and it can be too large to achieve a stable solution of the ODE.

The influence of such poles is often localized and therefore they can be discarded with the following update of the residues by clicking the **Update Residues** button. For the default tolerance, the approximation becomes worse after discarding the real-valued pole (see [Figure 6](#) on the left). Increasing the tolerance results in an extra complex-valued pole pair, and the result visually remains the same after the real-valued pole has been removed.

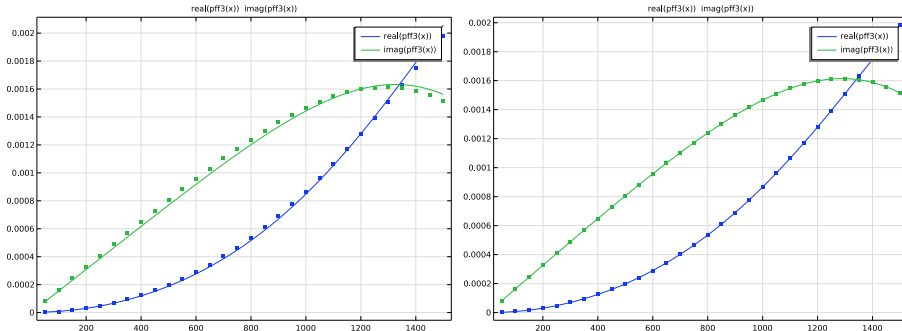

*Figure 6: Sofa admittance approximation computed with the tolerance of  $10^{-3}$  (left) and  $10^{-5}$  (right) after discarding the real-valued pole.*

The same procedure should be applied when the expansion contains spurious poles (also known as Froissart doublets). Those are the poles with residues close to zero, which is equivalent to very near pole and zero pairs in the rational approximation given by [Equation 3](#).

## MESH AND TIME EXPLICIT SOLVER

Solving wave propagation problems in the time domain has some requirements on both spatial and temporal resolution of the wave pattern. The mesh has to be fine enough to resolve the frequency content of the signal. For the quartic discretization used by default in the *Nonlinear Pressure Acoustic, Time Explicit* physics interface, the proper accuracy is achieved when the maximum mesh element size does not exceed  $2/3$  of the minimum wavelength. This tutorial studies the propagation of a broadband signal shown together with its frequency content in Figure 7. As seen, the frequency content is not limited by  $f_0 = 700$  Hz. Therefore, the mesh should resolve smaller wavelengths to achieve accurate results; at least up to  $\lambda_0/2 = c_0/(2f_0)$ . This yields  $h_{\max} \leq \lambda_0/3$ .

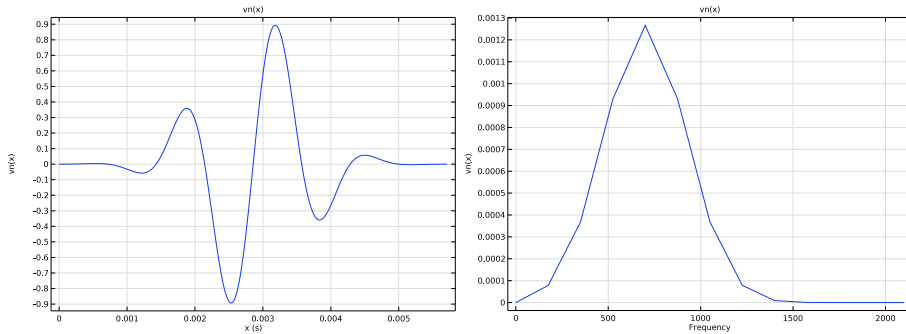

Figure 7: Source signal (left) and its frequency content (right).

The *Pressure Acoustic, Time Explicit* interface is based on dG-FEM and uses an explicit time integration schemes. The time step is supposed to obey the CFL condition to ensure the stability of the time integration method. That is,  $\Delta t \leq h_{\min}/c_0$ , where  $h_{\min}$  is the minimum mesh element size. The solver automatically deduces the time step from the mesh and the speed of sound.

## References

1. H. Wang, M. Cosnefroy, and M. Hornikx, “An arbitrary high-order discontinuous Galerkin method with local time-stepping for linear acoustic wave propagation,” *J. Acoust. Soc. Am.*, vol. 149, p. 569, 2021; [doi.org/10.1121/10.0003340](https://doi.org/10.1121/10.0003340).
2. F. Pind, A.P. Eising-Karup, C-H Jeong, J.S. Hesthaven, and J. Strømmand-Andersen, “Time-domain room acoustic simulations with extended-reacting porous absorbers using the discontinuous Galerkin method,” *J. Acoust. Soc. Am.*, vol. 148, p. 2851, 2020; [doi.org/10.1121/10.0002448](https://doi.org/10.1121/10.0002448).

3. H. Wang and M. Hornikx, “Time-domain impedance boundary condition modeling with the discontinuous Galerkin method for room acoustics simulations,” *J. Acoust. Soc. Am.*, vol. 147, p. 2534, 2020; [doi.org/10.1121/10.0001128](https://doi.org/10.1121/10.0001128).

---

**Application Library path:** Acoustics\_Module/Building\_and\_Room\_Acoustics/  
wave\_based\_room

---

### *Modeling Instructions*



---

From the **File** menu, choose **New**.

#### **NEW**

In the **New** window, click  **Model Wizard**.

#### **MODEL WIZARD**

- 1 In the **Model Wizard** window, click  **3D**.
- 2 In the **Select Physics** tree, select **Acoustics > Pressure Acoustics > Pressure Acoustics, Time Explicit (pate)**.
- 3 Click **Add**.
- 4 Click  **Study**.
- 5 In the **Select Study** tree, select **General Studies > Time Dependent**.
- 6 Click  **Done**.

This tutorial studies the propagation of an acoustic signal whose wavelength at the center frequency is large compared to most of the details of the model geometry. Thus, it is approved to change the **Geometry shape function** order to **Linear Lagrange**. This will increase the robustness of the model.

#### **COMPONENT 1 (COMPI)**





- 1 In the **Model Builder** window, click **Component 1 (comp1)**.
- 2 In the **Settings** window for **Component**, locate the **Curved Mesh Elements** section.
- 3 From the **Geometry shape function** list, choose **Linear Lagrange**.

#### **GEOMETRY 1**



- 1 In the **Model Builder** window, under **Component 1 (comp1)** click **Geometry 1**.

- 2 In the **Settings** window for **Geometry**, locate the **Advanced** section.
- 3 From the **Geometry representation** list, choose **CAD kernel**.
- 4 Locate the **Cleanup** section. Select the **Automatic detection of small details** checkbox.

#### *Import 1 (impl)*



- 1 In the **Home** toolbar, click  **Import**.
- 2 In the **Settings** window for **Import**, locate the **Source** section.
- 3 Click  **Browse**.
- 4 Browse to the model's Application Libraries folder and double-click the file `wave_based_room.mphbin`.
- 5 Click  **Import**.
- 6 Click the  **Wireframe Rendering** button in the **Graphics** toolbar.

#### *Point 1 (pt1)*

- 1 In the **Geometry** toolbar, click  **More Primitives** and choose **Point**.
- 2 In the **Settings** window for **Point**, locate the **Point** section.
- 3 In the **x** text field, type `1.2[m] 0.2[m] -0.8[m] -1.8[m]`.
- 4 In the **y** text field, type `0.75*1.75[m] 0.5*1.75[m] 0.25*1.75[m] 0[m]`.
- 5 In the **z** text field, type `1[m] 1[m] 1[m] 1[m]`.
- 6 Click  **Build Selected**.

### **DEFINITIONS**

#### *Sofa*



- 1 In the **Definitions** toolbar, click  **Explicit**.
- 2 In the **Settings** window for **Explicit**, type `Sofa` in the **Label** text field.
- 3 Locate the **Input Entities** section. From the **Geometric entity level** list, choose **Boundary**.
- 4 Click  **Paste Selection**.
- 5 In the **Paste Selection** dialog, type `10-20, 25-31, 51, 52, 61, 68-71` in the **Selection** text field.
- 6 Click **OK**.

#### *Sofa Legs*



- 1 In the **Definitions** toolbar, click  **Explicit**.
- 2 In the **Settings** window for **Explicit**, type `Sofa Legs` in the **Label** text field.
- 3 Locate the **Input Entities** section. From the **Geometric entity level** list, choose **Boundary**.

- 4 Click  **Paste Selection**.
- 5 In the **Paste Selection** dialog, type 21-24, 32-35, 53-56 in the **Selection** text field.
- 6 Click **OK**.



#### *Shelves*

- 1 In the **Definitions** toolbar, click  **Explicit**.
- 2 In the **Settings** window for **Explicit**, type **Shelves** in the **Label** text field.
- 3 Locate the **Input Entities** section. From the **Geometric entity level** list, choose **Boundary**.
- 4 Click  **Paste Selection**.
- 5 In the **Paste Selection** dialog, type 116-206, 265-270, 272-274, 277-279, 281-289 in the **Selection** text field.
- 6 Click **OK**.



#### *TV*

- 1 In the **Definitions** toolbar, click  **Explicit**.
- 2 In the **Settings** window for **Explicit**, type **TV** in the **Label** text field.
- 3 Locate the **Input Entities** section. From the **Geometric entity level** list, choose **Boundary**.
- 4 Click  **Paste Selection**.
- 5 In the **Paste Selection** dialog, type 241-261 in the **Selection** text field.
- 6 Click **OK**.

#### *TV Table*



- 1 In the **Definitions** toolbar, click  **Explicit**.
- 2 In the **Settings** window for **Explicit**, type **TV Table** in the **Label** text field.
- 3 Locate the **Input Entities** section. From the **Geometric entity level** list, choose **Boundary**.
- 4 Click  **Paste Selection**.
- 5 In the **Paste Selection** dialog, type 79-115, 233-240, 263, 264, 271, 275, 276, 280 in the **Selection** text field.
- 6 Click **OK**.

#### *Sofa Table*



- 1 In the **Definitions** toolbar, click  **Explicit**.
- 2 In the **Settings** window for **Explicit**, type **Sofa Table** in the **Label** text field.
- 3 Locate the **Input Entities** section. From the **Geometric entity level** list, choose **Boundary**.
- 4 Click  **Paste Selection**.

- 5 In the **Paste Selection** dialog, type 36-50, 57-60, 62-67, 72 in the **Selection** text field.
- 6 Click **OK**.



### *Speaker Legs*

- 1 In the **Definitions** toolbar, click  **Explicit**.
- 2 In the **Settings** window for **Explicit**, type Speaker Legs in the **Label** text field.
- 3 Locate the **Input Entities** section. From the **Geometric entity level** list, choose **Boundary**.
- 4 Click  **Paste Selection**.
- 5 In the **Paste Selection** dialog, type 207-212, 225-228 in the **Selection** text field.
- 6 Click **OK**.



### *Ceiling*

- 1 In the **Definitions** toolbar, click  **Explicit**.
- 2 In the **Settings** window for **Explicit**, type Ceiling in the **Label** text field.
- 3 Locate the **Input Entities** section. From the **Geometric entity level** list, choose **Boundary**.
- 4 Click  **Paste Selection**.
- 5 In the **Paste Selection** dialog, type 7, 77 in the **Selection** text field.
- 6 Click **OK**.

### *Carpet*

- 1 In the **Definitions** toolbar, click  **Explicit**.
- 2 In the **Settings** window for **Explicit**, type Carpet in the **Label** text field.
- 3 Locate the **Input Entities** section. From the **Geometric entity level** list, choose **Boundary**.
- 4 Click  **Paste Selection**.
- 5 In the **Paste Selection** dialog, type 3, 75 in the **Selection** text field.
- 6 Click **OK**.

### *Wall*

- 1 In the **Definitions** toolbar, click  **Explicit**.
- 2 In the **Settings** window for **Explicit**, type Wall in the **Label** text field.
- 3 Locate the **Input Entities** section. From the **Geometric entity level** list, choose **Boundary**.
- 4 Click  **Paste Selection**.
- 5 In the **Paste Selection** dialog, type 1, 2, 4, 5, 8, 9, 74, 78, 262 in the **Selection** text field.
- 6 Click **OK**.

### All Surfaces



- 1 In the **Definitions** toolbar, click  **Explicit**.
- 2 In the **Settings** window for **Explicit**, type All Surfaces in the **Label** text field.
- 3 Locate the **Input Entities** section. From the **Geometric entity level** list, choose **Boundary**.
- 4 Select the **All boundaries** checkbox.

### Listening Points

- 1 In the **Definitions** toolbar, click  **Explicit**.
- 2 In the **Settings** window for **Explicit**, locate the **Input Entities** section.
- 3 From the **Geometric entity level** list, choose **Point**.
- 4 Select Points 35, 53, 121, and 122 only.
- 5 In the **Label** text field, type Listening Points.

Create four **Point Probes** for calculating the acoustic pressure on the way from the loudspeaker to the sofa.

### Point Probe 1 (point1)

- 1 In the **Definitions** toolbar, click  **Probes** and choose **Point Probe**.
- 2 In the **Settings** window for **Point Probe**, locate the **Source Selection** section.
- 3 Click  **Clear Selection**.
- 4 Select Point 122 only.
- 5 Locate the **Expression** section. In the **Expression** text field, type  $p_{at}e.p_t/(1[m/s]^*p_{at}e.Z)$ .
- 6 Select the **Description** checkbox. In the associated text field, type LP1.

### Point Probe 2 (point2)

- 1 Right-click **Point Probe 1 (point1)** and choose **Duplicate**.
- 2 In the **Settings** window for **Point Probe**, locate the **Source Selection** section.
- 3 Click  **Clear Selection**.
- 4 Select Point 121 only.
- 5 Locate the **Expression** section. In the **Description** text field, type LP2.

### Point Probe 3 (point3)

- 1 Right-click **Point Probe 2 (point2)** and choose **Duplicate**.
- 2 In the **Settings** window for **Point Probe**, locate the **Source Selection** section.
- 3 Click  **Clear Selection**.

- 4 Select Point 53 only.
- 5 Locate the **Expression** section. In the **Description** text field, type LP3.

*Point Probe 4 (point4)*

- 1 Right-click **Point Probe 3 (point3)** and choose **Duplicate**.
- 2 In the **Settings** window for **Point Probe**, locate the **Source Selection** section.
- 3 Click  **Clear Selection**.
- 4 Select Point 35 only.
- 5 Locate the **Expression** section. In the **Description** text field, type LP4.



## GLOBAL DEFINITIONS

*Parameters 1*

- 1 In the **Model Builder** window, under **Global Definitions** click **Parameters 1**.
- 2 In the **Settings** window for **Parameters**, locate the **Parameters** section.
- 3 In the table, enter the following settings:

Name	Expression	Value	Description
f0	700[Hz]	700 Hz	Signal center frequency
T0	1/f0	0.0014286 s	Signal period at center frequency
c0	343[m/s]	343 m/s	Speed of sound
lam0	c0/f0	0.49 m	Signal wavelength at center frequency

*Waveform 1 (wv1)*

- 1 In the **Home** toolbar, click  **Functions** and choose **Global > Waveform**.
- 2 In the **Settings** window for **Waveform**, type v<sub>n</sub> in the **Function name** text field.
- 3 Locate the **Parameters** section. In the *T* text field, type T0.
- 4 Click to expand the **Modulation** section. From the **Amplitude modulation** list, choose **Gaussian**.
- 5 In the  $\sigma$  text field, type T0/2.
- 6 Click  **Create Plot**.

## RESULTS

### *Source Signal Frequency Content*





In the **Settings** window for **ID Plot Group**, type Source Signal Frequency Content in the **Label** text field.

### *Function 1*



- 1 In the **Model Builder** window, expand the **Source Signal Frequency Content** node, then click **Function 1**.
- 2 In the **Settings** window for **Function**, locate the **Output** section.
- 3 From the **Display** list, choose **Discrete Fourier transform**.
- 4 From the **Show** list, choose **Frequency spectrum**.
- 5 From the **Scale** list, choose **Multiply by sampling period**.
- 6 Select the **Frequency range** checkbox.
- 7 In the **Maximum** text field, type  $3 \cdot f_0$ .
- 8 In the **Source Signal Frequency Content** toolbar, click  **Plot**.



## GLOBAL DEFINITIONS

### *Partial Fraction Fit - Carpet*







- 1 In the **Home** toolbar, click  **Functions** and choose **Global > Partial Fraction Fit**.
- 2 In the **Settings** window for **Partial Fraction Fit**, type Partial Fraction Fit - Carpet in the **Label** text field.
- 3 Locate the **Data** section. Click  **Browse**.
- 4 Browse to the model's Application Libraries folder and double-click the file `wave_based_room_admittance_carpet.txt`.  
Tighten the tolerance for the result to fulfill the passivity condition.
- 5 Click to expand the **Advanced** section. In the **Tolerance** text field, type  $1e-5$ .
- 6 Click  **Fit Parameters**.
- 7 Click  **Plot**.

### *Partial Fraction Fit - Ceiling*



- 1 In the **Home** toolbar, click  **Functions** and choose **Global > Partial Fraction Fit**.
- 2 In the **Settings** window for **Partial Fraction Fit**, type Partial Fraction Fit - Ceiling in the **Label** text field.
- 3 Locate the **Data** section. Click  **Browse**.

- 4 Browse to the model's Application Libraries folder and double-click the file `wave_based_room_admittance_ceiling.txt`.
- 5 Click  **Fit Parameters**.  
One of the real-valued poles is unstable and should be flipped to the left half plane by clicking the **Flip Poles** button. On the other hand, its residue is much smaller than those for the other poles, which indicates that the approximant may have a zero near the pole location. Run the cleanup procedure to remove the unstable pole.
- 6 Locate the **Advanced** section. Select the **Automatically detect and remove Froissart doublets** checkbox.
- 7 Click  **Fit Parameters**.
- 8 Click  **Plot**.

#### *Partial Fraction Fit - Sofa*



- 1 In the **Home** toolbar, click  **Functions** and choose **Global > Partial Fraction Fit**.
- 2 In the **Settings** window for **Partial Fraction Fit**, type `Partial Fraction Fit - Sofa` in the **Label** text field.
- 3 Locate the **Data** section. Click  **Browse**.
- 4 Browse to the model's Application Libraries folder and double-click the file `wave_based_room_admittance_sofa.txt`.  
Tune the tolerance and discard the real-valued pole as discussed earlier.
- 5 Locate the **Advanced** section. In the **Tolerance** text field, type `1e-5`.
- 6 Click  **Fit Parameters**.
- 7 Locate the **Poles and Residues** section. Find the **Real residues and poles** subsection. Click  **Clear Table** or **Delete** the table row containing the real-valued residue and pole.
- 8 Click  **Update Residues**.
- 9 Click  **Plot**.

#### *Partial Fraction Fit - Wall*

- 1 In the **Home** toolbar, click  **Functions** and choose **Global > Partial Fraction Fit**.
- 2 In the **Settings** window for **Partial Fraction Fit**, type `Partial Fraction Fit - Wall` in the **Label** text field.
- 3 Locate the **Data** section. Click  **Browse**.
- 4 Browse to the model's Application Libraries folder and double-click the file `wave_based_room_admittance_wall.txt`.
- 5 Click  **Fit Parameters**.

6 Click  **Plot**.

#### ADD MATERIAL

- 1 In the **Materials** toolbar, click  **Add Material** to open the **Add Material** window.
- 2 Go to the **Add Material** window.
- 3 In the tree, select **Built-in > Air**.
- 4 Click the **Add to Component** button in the window toolbar.
- 5 In the **Materials** toolbar, click  **Add Material** to close the **Add Material** window.

The model setup demonstrated below makes it possible to use an optimized solver that can be run on either a CPU or a GPU.

#### PRESSURE ACOUSTICS, TIME EXPLICIT (PATE)

- 1 In the **Settings** window for **Pressure Acoustics, Time Explicit**, locate the **Model Equation and Solver Settings** section.
- 2 Select the **Use accelerated solver formulation** checkbox.  
If you have a GPU that is powerful enough to speed up the computation, keep the other settings unchanged, otherwise
- 3 Clear the **Compute residual on GPU** checkbox to run the accelerated solver on the CPU.

#### *Normal Velocity 1*

- 1 In the **Model Builder** window, expand the **Pressure Acoustics, Time Explicit (pate)** node.
- 2 Right-click **Pressure Acoustics, Time Explicit (pate)** and choose **Normal Velocity**.
- 3 Select Boundary 222 only.

Unlike the ‘regular’ solver, the accelerated solver requires that the prescribed fields be given as a product of their spatial and temporal parts. Specify the **Normal Velocity** as shown below.

- 4 In the **Settings** window for **Normal Velocity**, locate the **Normal Velocity** section.
- 5 In the  $v_n(x)$  text field, type 1.
- 6 In the  $l(t)$  text field, type  $v_n(t)$ .

#### *Impedance 1 - Carpet*

- 1 In the **Physics** toolbar, click  **Boundaries** and choose **Impedance**.
- 2 In the **Settings** window for **Impedance**, type Impedance 1 - Carpet in the **Label** text field.
- 3 Locate the **Boundary Selection** section. From the **Selection** list, choose **Carpet**.

- 4 Locate the **Impedance** section. From the **Impedance model** list, choose **General local reacting (rational approximation)**.
- 5 From the **Partial fraction fit** list, choose **From function**.
- 6 From the **Reference** list, choose **Partial Fraction Fit - Carpet (pff1)**.
- 7 Click  **Import**.

#### *Impedance 2 - Ceiling*

- 1 Right-click **Impedance 1 - Carpet** and choose **Duplicate**.
- 2 In the **Settings** window for **Impedance**, type Impedance 2 - Ceiling in the **Label** text field.
- 3 Locate the **Boundary Selection** section. From the **Selection** list, choose **Ceiling**.
- 4 Locate the **Impedance** section. From the **Reference** list, choose **Partial Fraction Fit - Ceiling (pff2)**.
- 5 Click  **Import**.

#### *Impedance 3 - Sofa*

- 1 Right-click **Impedance 2 - Ceiling** and choose **Duplicate**.
- 2 In the **Settings** window for **Impedance**, type Impedance 3 - Sofa in the **Label** text field.
- 3 Locate the **Boundary Selection** section. From the **Selection** list, choose **Sofa**.
- 4 Locate the **Impedance** section. From the **Reference** list, choose **Partial Fraction Fit - Sofa (pff3)**.
- 5 Click  **Import**.

#### *Impedance 4 - Wall*

- 1 Right-click **Impedance 3 - Sofa** and choose **Duplicate**.
- 2 In the **Settings** window for **Impedance**, type Impedance 4 - Wall in the **Label** text field.
- 3 Locate the **Boundary Selection** section. From the **Selection** list, choose **Wall**.
- 4 Locate the **Impedance** section. From the **Reference** list, choose **Partial Fraction Fit - Wall (pff4)**.
- 5 Click  **Import**.

## **MESH 1**

#### *Swept 1*

- 1 In the **Mesh** toolbar, click  **Swept**.
- 2 In the **Settings** window for **Swept**, locate the **Domain Selection** section.

- 3 From the **Geometric entity level** list, choose **Domain**.
- 4 Select Domain 2 only.

#### *Free Triangular 1*

- 1 In the **Mesh** toolbar, click  **More Generators** and choose **Free Triangular**.
- 2 In the **Settings** window for **Free Triangular**, locate the **Boundary Selection** section.
- 3 From the **Selection** list, choose **Sofa**.

#### *Free Tetrahedral 1*

- 1 In the **Mesh** toolbar, click  **Free Tetrahedral**.
- 2 In the **Settings** window for **Free Tetrahedral**, click to expand the **Element Quality Optimization** section.
- 3 From the **Optimization level** list, choose **High**.
- 4 Select the **Avoid elements that are too small** checkbox.

#### *Size*

- 1 In the **Model Builder** window, click **Size**.
- 2 In the **Settings** window for **Size**, locate the **Element Size** section.
- 3 Click the **Custom** button.
- 4 Locate the **Element Size Parameters** section. In the **Maximum element size** text field, type  $1\text{m}0/3$ .
- 5 In the **Minimum element size** text field, type  $0.04$ .
- 6 In the **Curvature factor** text field, type  $0.3$ .
- 7 Click  **Build All**.

## **STUDY 1**

#### *Step 1: Time Dependent*

- 1 In the **Model Builder** window, under **Study 1** click **Step 1: Time Dependent**.
- 2 In the **Settings** window for **Time Dependent**, locate the **Study Settings** section.
- 3 In the **Output times** text field, type range  $(0, T_0, 30 * T_0)$ .

This setting specifies at which time steps the solution is saved and only influences the stored solution (and thus the file size). The internal time steps taken by the solver are automatically controlled by COMSOL to fulfill the appropriate CFL condition. Note that the acoustic pressure recorded at the probe points is computed with a higher resolution at the time steps taken by the solver.

4 Click to expand the **Store in Output** section. In the table, enter the following settings:

Interface	Output	Selection
Pressure Acoustics, Time Explicit (pate)	Selection	

5 Under **Selections**, click **+ Add**.

6 In the **Add** dialog, select **All Surfaces** in the **Selections** list.

7 Click **OK**.

8 In the **Model Builder** window, click **Study 1**.

9 In the **Settings** window for **Study**, locate the **Study Settings** section.

10 Clear the **Generate default plots** checkbox.

11 In the **Study** toolbar, click **t=0** **Get Initial Value**.

## RESULTS

### *Point Probe 1*

Increase the table size as there will be more than 10000 cells in the probe table.

## PROBE TABLE 1

1 Go to the **Probe Table 1** window.

2 Click the **Settings** button in the window toolbar.

## RESULTS

### *Probe Table 1*

1 In the **Settings** window for **Table**, locate the **Display** section.

2 In the **Maximum number of rows displayed** text field, type 20000.

## STUDY 1

In the **Study** toolbar, click **= Compute**.

All the plots are depicted in the previous sections of the documentation.

## RESULTS

### *Normalized Acoustic Pressure at Listening Points*

1 In the **Model Builder** window, under **Results** click **Probe Plot Group 2**.

2 In the **Settings** window for **ID Plot Group**, type Normalized Acoustic Pressure at Listening Points in the **Label** text field.

- 3 Click to expand the **Title** section. From the **Title type** list, choose **Label**.
- 4 Locate the **Plot Settings** section.
- 5 Select the **y-axis label** checkbox. In the associated text field, type `p_normalized (1)`.

#### *Probe Table Graph 1*

- 1 In the **Model Builder** window, expand the **Normalized Acoustic Pressure at Listening Points** node, then click **Probe Table Graph 1**.
- 2 In the **Settings** window for **Table Graph**, click to expand the **Legends** section.
- 3 From the **Legends** list, choose **Manual**.
- 4 In the table, enter the following settings:

Legends
LP1
LP2
LP3
LP4

- 5 In the **Normalized Acoustic Pressure at Listening Points** toolbar, click  **Plot**.



#### *Normalized Acoustic Pressure*

- 1 In the **Results** toolbar, click  **3D Plot Group**.
- 2 In the **Settings** window for **3D Plot Group**, type `Normalized Acoustic Pressure` in the **Label** text field.
- 3 Locate the **Data** section. From the **Time (s)** list, choose **0.015714**.
- 4 Click to expand the **Title** section. From the **Title type** list, choose **Label**.
- 5 Locate the **Color Legend** section. Select the **Show maximum and minimum values** checkbox.
- 6 Select the **Show units** checkbox.

#### *Surface 1*

- 1 In the **Normalized Acoustic Pressure** toolbar, click  **Surface**.
- 2 In the **Settings** window for **Surface**, locate the **Expression** section.
- 3 In the **Expression** text field, type `pate.p_t / (1[m/s] * pate.Z)`.
- 4 Locate the **Coloring and Style** section. From the **Color table** list, choose **Wave**.
- 5 From the **Scale** list, choose **Linear symmetric**.

### *Selection 1*

- 1** In the **Normalized Acoustic Pressure** toolbar, click  **Selection**.
- 2** In the **Settings** window for **Selection**, locate the **Selection** section.
- 3** Click  **Paste Selection**.
- 4** In the **Paste Selection** dialog, type 3, 8-72, 75, 78-289 in the **Selection** text field.
- 5** Click **OK**.