



Model created in COMSOL Multiphysics 6.4

Ultrasound Flowmeter with Generic Time-of-Flight Configuration

Introduction

Knowing the speed of a moving fluid is important in all cases where the fluid is used to transport material or energy. It just so happens that this process is fundamental to such a great part of the tasks we do or interact with in our everyday lives: from industrial applications in production of, for instance, foods and beverages, drugs, and other chemicals, to personal tasks such as measuring water consumption at your house or determining how much gas was pumped into your car, and to medical applications like determining the flow of blood in the veins or the inhalation of air into the lungs. Thus, it should come as no surprise that a large variety of methods have been developed to determine the flow speed.

In the time-of-flight or transit-time method for determining flow speed an ultrasonic signal is transmitted across the main flow in a pipe to noninvasively determine its speed. By transmitting the signal at an angle relative to the main flow, the ultrasound signal will travel faster than the speed of sound if it moves in the direction of the main flow, or slower than the speed of sound if it moves against it. The difference in travel times in the two directions increases linearly with the speed of the main flow. It is therefore possible to infer the speed of the main flow without putting any physical objects into it. Flowmeters of this type find many uses, particularly in industrial settings where their noninvasiveness is advantageous. Examples include abrasive, corrosive, and sanitary flows, and in fact all flows in which immersed objects would degrade or significantly obstruct the flow.

The only major limitation to the use of time-of-flight ultrasound flowmeters is for fluids containing significant amounts of bubbles or suspended particles. The reason is that the ultrasound will be attenuated significantly by the objects resulting in only a very weak signal arriving at the sensor across the main pipe. To measure the flow speed in these cases, a single combined transmitter and receiver emits the ultrasound, which is reflected off the suspended objects, and the flow speed can be calculated from the Doppler shift between the emitted and received signal.

Here we illustrate how to model a generic wetted transient-time ultrasound flowmeter in COMSOL Multiphysics. Wetted ultrasound flowmeters have a dedicated signal tube for the ultrasound signal, and the whole device is therefore mounted into the industrial plant. Conversely, portable clamp-on ultrasound flowmeters also exist, they are mounted on the outside of the main pipe during operation; this type of flowmeter is less accurate due to ultrasound interference resulting from transmitting the signal through the pipe wall.

The model setup here solves the transient problem of a signal traversing the flow downstream. The signal moving upstream is precalculated and imported as data. The difference in arrival times is used to estimate the speed of the main flow. Due to the high

frequency of the employed signal (~ 2.5 MHz), the model uses the Convected Wave Equation, Time Explicit physics interface, found under the Ultrasound branch, which is tailored to transient high-frequency situations. The method is very memory efficient and is able to solve the ~ 7.5 million degrees of freedom ($\sim 10^7$ DOFs) of this model using around 10 GB of RAM.

Note: This application requires both the Acoustics Module and the CFD Module.

Model Definition

A schematic illustration of the modeled ultrasound flowmeter (using one symmetry plane) with annotations and geometry is shown in [Figure 1](#).

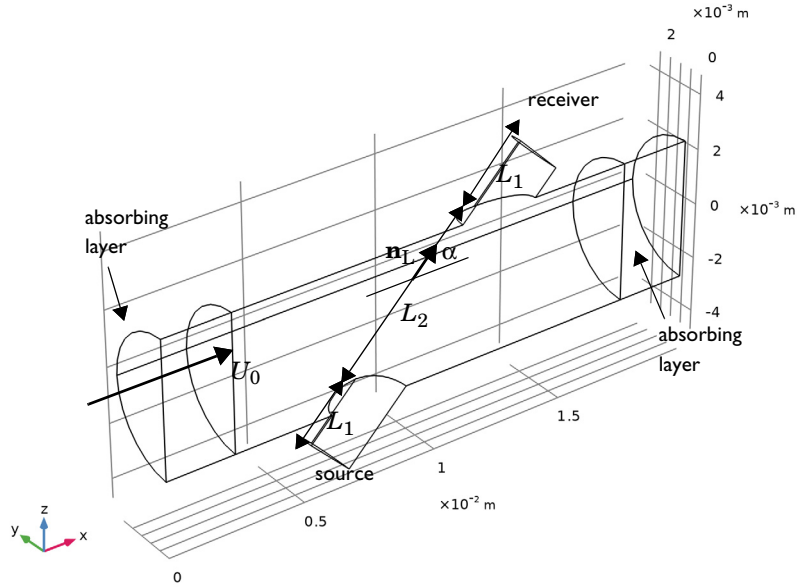

Figure 1: Schematic illustration of ultrasound flowmeter. The smaller signal tube of length L_1 is angled relative to the main pipe which contains the flow under investigation.

The flowmeter consists of a main pipe and a smaller signal tube (transducer duct), which is placed at some angle α relative to the main pipe. The diameter D of the main pipe is 5 mm while the signal tube has a diameter of 2 mm and is angled at $\alpha = 45^\circ$ relative to the main pipe. The length of the signal tube is $L = 2L_1 + L_2$. The fluid is taken to be water at

normal atmospheric conditions, and the mean speed of the background flow is taken to be $U_0 = 10$ m/s.

This model solves the full three-dimensional problem. The axial symmetry is exploited for computational efficiency, so only half the channel is modeled.

BACKGROUND FLOW: CFD

The first step in the modeling procedure is to establish a realistic background flow (p_0 , \mathbf{u}_0). This flow is taken to be stationary and is obtained using a CFD simulation. The background flow is expected to be turbulent with a Reynolds number (Re) of about $5 \cdot 10^4$ under the operating conditions. The flow is modeled using the Turbulent Flow, $k\text{-}\omega$ interface of the CFD Module.

ACOUSTICS: CONVECTED WAVE EQUATION, TIME EXPLICIT

In the acoustics problem, an ultrasound interrogation signal is prescribed at the transducer (signal) end of the signal tube. The time-of-flight method requires that a signal is sent from both ends, so in an actual devices both of these ends act as transmitters as well as receivers. In the current model we only model the signal moving downstream while the signal moving upstream is imported from a data file. The data can easily be generated by simply switching the source and receiver boundaries.

The interrogation signal is a sine wave modulated with a Gaussian pulse. It is modeled by prescribing the normal velocity v_n at the source boundary

$$v_n(t) = A e^{-(f_0(t-3T_0))^2} \sin(\omega_0 t) \quad (1)$$

where $A = 0.1$ mm is the signal amplitude, $\omega_0 = 2\pi f_0$, $f_0 = 2.5$ MHz, and $T_0 = 1/f_0$. The signal in [Equation 1](#) has a bandwidth of roughly f_0 , which is the same as the carrying signal frequency. Using the Convected Wave Equation, Time Explicit interface, the mesh needs to have a size roughly half the size of the smallest wavelength λ_0 (largest frequency) that should be resolved. This is the case since the interface, per default, uses fourth-order shape functions. This combination of mesh size and shape functions gives the optimal performance for the discontinuous Galerkin method, on which the interface is based.

ESTIMATING THE FLOW SPEED

One can construct an estimate of the time it takes the two signals to reach their receivers on the opposite side. This estimate can be used to derive an approximate expression for the mean speed of the background flow U_0 ; in fact, this is the working principle behind ultrasound flowmeters. That is, measure the time difference ΔT between the two emitted

signals and use this time to derive the mean flow speed, possibly corrected by a correction factor as described below.

The background flow is predominantly in the main tube, with very low speeds in the signal tube; see [Figure 1](#). The distance of the signal tube across the main pipe is denoted by L_2 , while the part extending on either side has axial length L_1 (the side branches). Thus, the total signal tube length satisfies $L = 2L_1 + L_2$. The direction of the signal tube is denoted by \mathbf{n}_L with the angle between the signal tube and the main pipe being the aforementioned α . Assuming that the background flow in the side branches can be neglected, the time T_1 it takes to traverse is therefore $T_1 = L_1/c_0$, independently of whether the ultrasound signal is moving upstream or downstream. Now, assuming that the background flow is constant across the main pipe (this can be a reasonable approximation for very turbulent flows), the velocity field can be written as $\mathbf{u}_0 = U_0\mathbf{e}_x$. The time T_2 it takes the signal to propagate the distance L_2 depends on whether it is moving upstream or downstream. The time T_2 is, under the assumptions made,

$$T_{2, \text{upstream}} = \frac{L_2}{c_0 + \mathbf{n}_L \cdot \mathbf{u}_0} = \frac{L_2}{c_0 + U_0 \cos \alpha}$$

$$T_{2, \text{downstream}} = \frac{L_2}{c_0 - \mathbf{n}_L \cdot \mathbf{u}_0} = \frac{L_2}{c_0 - U_0 \cos \alpha}$$

where c_0 is the speed of sound. Therefore, the expected time difference ΔT between the two signals is given by

$$\Delta T = T_{2, \text{downstream}} - T_{2, \text{upstream}} = \frac{2L_2 U_0 \cos \alpha}{c_0^2 - U_0^2 (\cos \alpha)^2}$$

This expression above can be used to estimate the average background mean flow based on a measurement of the time difference ΔT . The expression is

$$U_0 = \frac{L_2}{\Delta T \cos \alpha} \left(-1 + \sqrt{1 + \frac{\Delta T^2 c_0^2}{L_2^2}} \right) \quad (2)$$

Note that a critical simplifying assumption for [Equation 2](#) is that the background flow is constant across the tube. In reality, most background flows are not constant across the main pipe. The extreme case is laminar flow where the flow profile will be a parabola, but typical turbulent flow will also exhibit a varying velocity profile.

Results and Discussion

The background mean flow is first simulated using the Turbulent Flow interface from the CFD Module. The velocity amplitude and flow profile are depicted in [Figure 2](#) and [Figure 3](#), respectively.

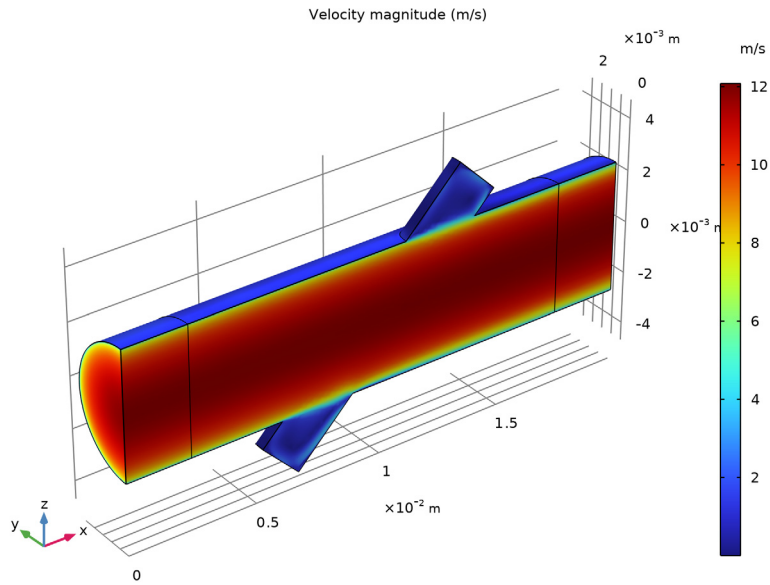

Figure 2: Background mean flow magnitude in the flowmeter.

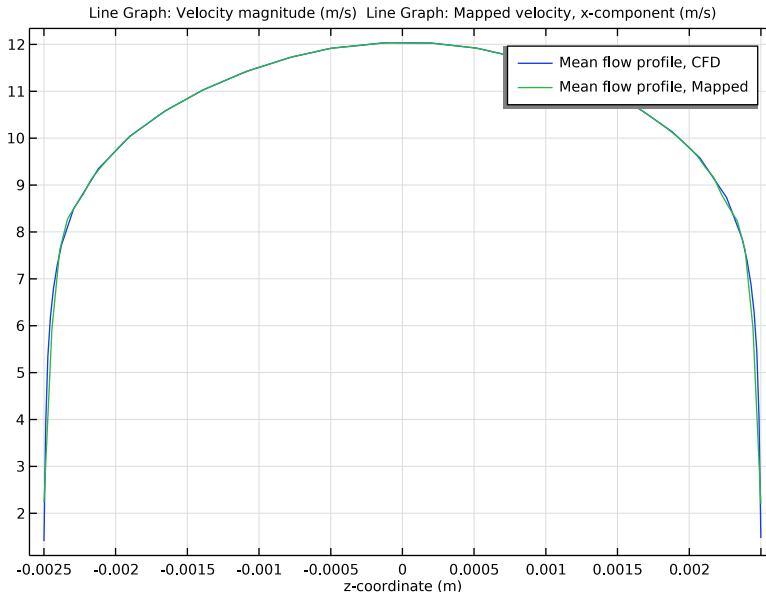

Figure 3: Background mean flow profile, plotted through the cross section of the main duct.

The acoustic pressure in the symmetry plane of the flowmeter is depicted for four different times in Figure 4. This sequence (including all stored times) can be animated within COMSOL under the **Export** node selecting **Animation > Player**. This gives a very intuitive way to visualize the propagating pulse.

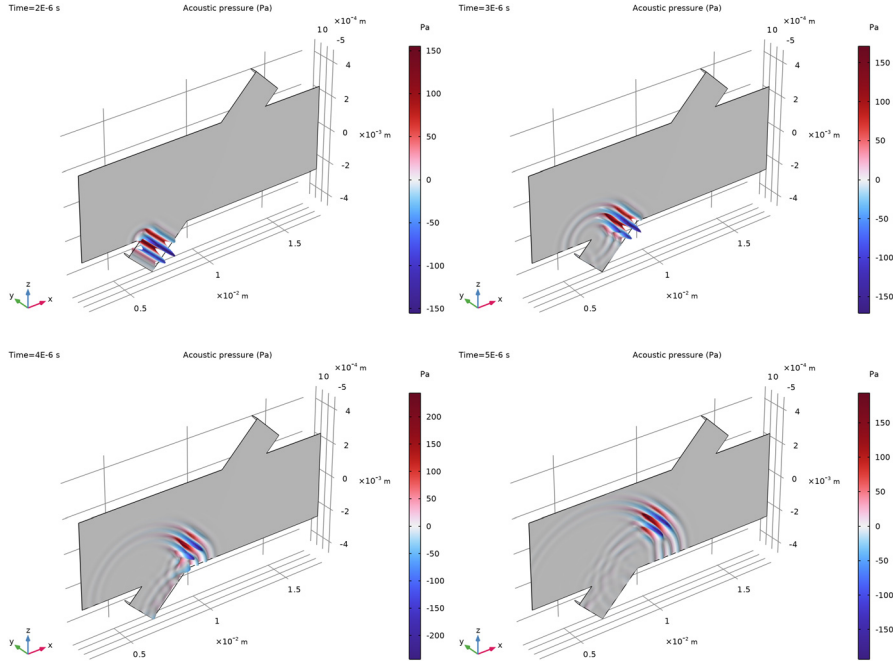

Figure 4: Pressure signal in the symmetry plane of the ultrasound flowmeter at 4 times.

The acoustic particle velocity at a time $t = 8 \cdot 10^{-6}$ s just before the pulse reaches the receiver is depicted in Figure 5. The instantaneous intensity amplitude and the intensity vectors (normalized) are depicted in Figure 6 at the same instance as the acoustic velocity in Figure 5. The intensity plot provides a better visualization of the energy flow of the acoustic signal in the flowmeter system.

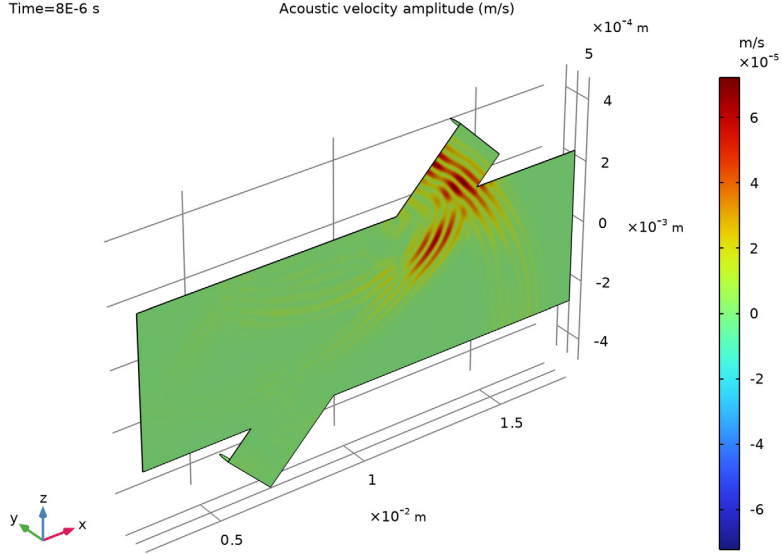

Figure 5: Acoustic particle velocity in the symmetry plane of the flowmeter.

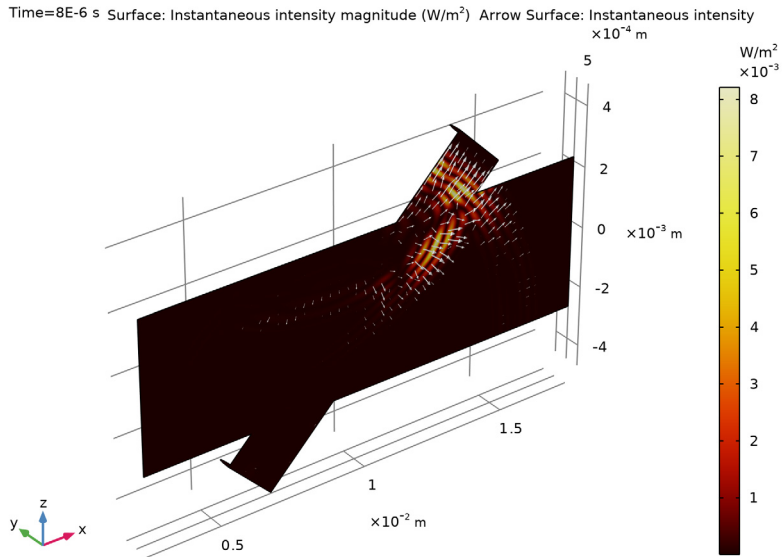

Figure 6: Acoustic instantaneous intensity amplitude (colors) and normalized intensity vectors as white arrows depicted just before the signal reaches the receiver.

In [Figure 7](#), the pressure signal is depicted at time $t = 4 \cdot 10^{-6}$ s along the main axis of the transducer tube (see [Figure 1](#)). Finally, [Figure 8](#) shows one of the important results of this model. The average pressure as recorded on the receiver for the signal moving downstream and the signal moving upstream. The latter data is imported but can easily be generated by switching the source and receiver selections. Using this figure, it is possible to measure the time difference between the two signals. By zooming in on the figure and using visual inspection, it can be found to be $\Delta T_{\text{simulated}} = 4.86 \cdot 10^{-8}$ s (this is stored in the parameter `DT_simulated`).

This simulated time difference can be compared with the expected time difference that can be calculated for the known flow profile $\mathbf{u}_0(\mathbf{x})$ (the flow profile is, of course, not normally known in measurements). The calculated time ΔT_{calc} is given by

$$\Delta T_{\text{calc}} = \int_0^L \left[\frac{1}{c_0 - \mathbf{n}_L \cdot \mathbf{u}_0(\mathbf{x})} - \frac{1}{c_0 + \mathbf{n}_L \cdot \mathbf{u}_0(\mathbf{x})} \right] dl \quad (3)$$

This integral is evaluated under **Results > Derived Values** node and it gives

$\Delta T_{\text{calc}} = 5.01 \cdot 10^{-8}$ s which is very close the simulated (visually read) value mentioned above (ΔT_{calc} is stored in the parameter `DT_calc`).

Now, using the simulated time difference $\Delta T_{\text{simulated}}$ in the expression for the estimated mean flow velocity given in [Equation 2](#) you get $U_{0,\text{est}} = 10.66$ m/s. This value is evaluated (both for the simulated and the calculated time differences) under the **Results > Derived Values** node.

FLOW PROFILE CORRECTION FACTOR

The error in estimating U_0 from the simplified model above is one of the central problems with data analysis for ultrasound flowmeters ([Ref. 1](#)). This is typically described by the flow profile correction factor (FPCF)

$$\text{FPCF} = \frac{\text{Measured average flow speed along tube}}{\text{Actual average mean flow speed}}$$

The issue in determining FPCF theoretically is that the background flow, in general, is not known; this is especially true for turbulent flows. Moreover, the flow profile across the signal tube likely depends on the acoustic medium, the flow speed, the pitch angle α as well as design parameters such as the radii of the main pipe and the signal tube.

In this model, we do not make any explicit assumptions about the exact velocity profile in the signal tube. Instead, this is determined by the CFD simulation and therefore explicitly include contributions from all the unknown factors listed above. Therefore, COMSOL

Multiphysics can be used to calculate the instrument-specific FPCF, resulting in more accurate instruments across varying flow speeds and geometries. We find for the specific case above

$$\text{FPCF} = \frac{10.66 \text{ m/s}}{10.0 \text{ m/s}} = 1.066$$

and the model could easily be extended to sweep across, for instance, flow speed and thus obtain FPCF for each situation. Tabulating these values would allow users to obtain the correct result across different working conditions; such tables can easily be included into the data analysis software shipped with the instrument.

Other factors affecting the performance of the flowmeter can also be investigated and simulated. For example, the geometry of the signal tubes and how they taper into the main duct could be of interest. Maybe avoiding unnecessary reflections and diffractions. The modification of the emitted acoustic signal by the flow profile (due to gradients in the flow or even density gradients) can also be studied and used to enhance the detection technique and allowing better prediction of the flow profile.

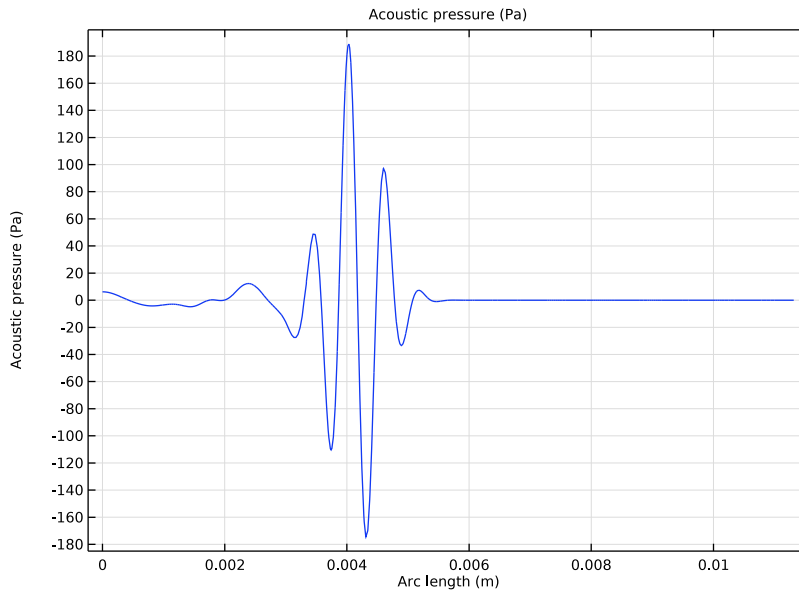

Figure 7: Acoustic pressure signal depicted along the central transducer axis.

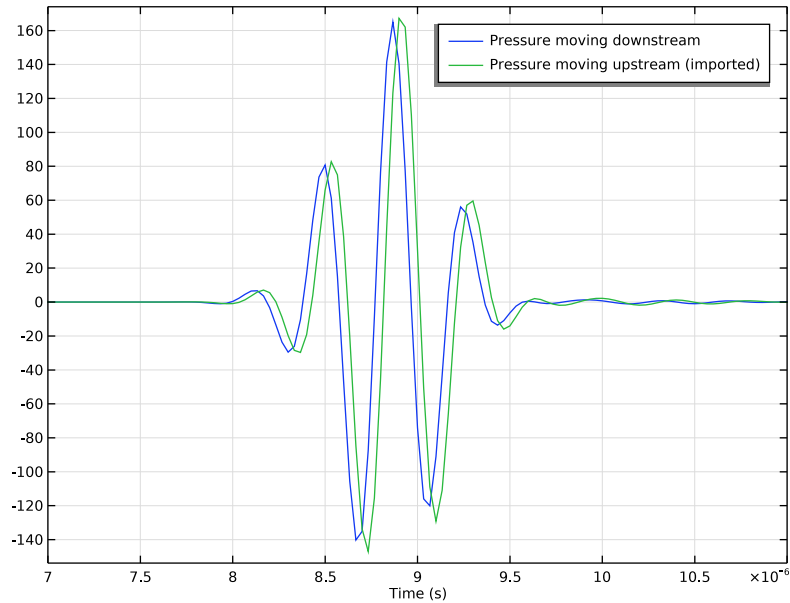

Figure 8: The average acoustic pressure on the receiver for the signal moving downstream (modeled in this tutorial) and the signal moving upstream (data imported).

Reference

I. J.C. Jung and P.H. Seong, “Estimation of the Flow Profile Correction Factor of a Transit-Time Ultrasonic Flow Meter for the Feedwater Flow Measurement in a Nuclear Power Plant,” IEEE Transactions on Nuclear Science, vol. 52, 2005.

Application Library path: Acoustics_Module/Ultrasound/
ultrasound_flow_meter_generic



Modeling Instructions

From the **File** menu, choose **New**.

NEW

In the **New** window, click  **Model Wizard**.

MODEL WIZARD

- 1 In the **Model Wizard** window, click  **3D**.
- 2 In the **Select Physics** tree, select **Fluid Flow > Single-Phase Flow > Turbulent Flow > Turbulent Flow, k- ω (spf)**.
- 3 Click **Add**.
- 4 Click  **Study**.
- 5 In the **Select Study** tree, select **General Studies > Stationary**.
- 6 Click  **Done**.

GLOBAL DEFINITIONS

Parameters 1

- 1 In the **Model Builder** window, under **Global Definitions** click **Parameters 1**.
- 2 In the **Settings** window for **Parameters**, locate the **Parameters** section.
- 3 Click  **Load from File**.
- 4 Browse to the model's Application Libraries folder and double-click the file `ultrasound_flow_meter_generic_parameters.txt`.

GEOMETRY 1

Cylinder 1 (cyl1)

- 1 In the **Geometry** toolbar, click  **Cylinder**.
- 2 In the **Settings** window for **Cylinder**, locate the **Size and Shape** section.
- 3 In the **Radius** text field, type $D/2$.
- 4 In the **Height** text field, type L .
- 5 Locate the **Axis** section. From the **Axis type** list, choose **x-axis**.
- 6 Click to expand the **Layers** section. In the table, enter the following settings:

Layer name	Thickness (m)
Layer 1	$0.5 * D$



- 7 Clear the **Layers on side** checkbox.
- 8 Select the **Layers on bottom** checkbox.
- 9 Select the **Layers on top** checkbox.

Cylinder 2 (cyl2)

- 1 In the **Geometry** toolbar, click  **Cylinder**.

- 2 In the **Settings** window for **Cylinder**, locate the **Size and Shape** section.
- 3 In the **Radius** text field, type $D_transducer/2$.
- 4 In the **Height** text field, type $L_transducer$.
- 5 Locate the **Position** section. In the **x** text field, type $L/2$.
- 6 In the **z** text field, type $-L_transducer/2$.

Rotate 1 (rot1)

- 1 In the **Geometry** toolbar, click  **Transforms** and choose **Rotate**.
- 2 Select the object **cyl2** only.
- 3 In the **Settings** window for **Rotate**, locate the **Rotation** section.
- 4 In the **Angle** text field, type α .
- 5 Locate the **Point on Axis of Rotation** section. In the **x** text field, type $L/2$.
- 6 Locate the **Rotation** section. From the **Axis type** list, choose **y-axis**.
- 7 Click  **Build All Objects**.



Union 1 (unil)

- 1 In the **Geometry** toolbar, click  **Booleans and Partitions** and choose **Union**.
- 2 Click in the **Graphics** window and then press **Ctrl+A** to select both objects.
- 3 In the **Settings** window for **Union**, click  **Build All Objects**.

Work Plane 1 (wp1)

- 1 In the **Geometry** toolbar, click  **Work Plane**.
- 2 In the **Settings** window for **Work Plane**, locate the **Plane Definition** section.
- 3 From the **Plane** list, choose **zx-plane**.

Partition Objects 1 (par1)

- 1 In the **Geometry** toolbar, click  **Booleans and Partitions** and choose **Partition Objects**.
- 2 Select the object **unil** only.
- 3 In the **Settings** window for **Partition Objects**, locate the **Partition Objects** section.
- 4 From the **Partition with** list, choose **Work plane**.
- 5 Click  **Build All Objects**.

Delete Entities 1 (del1)

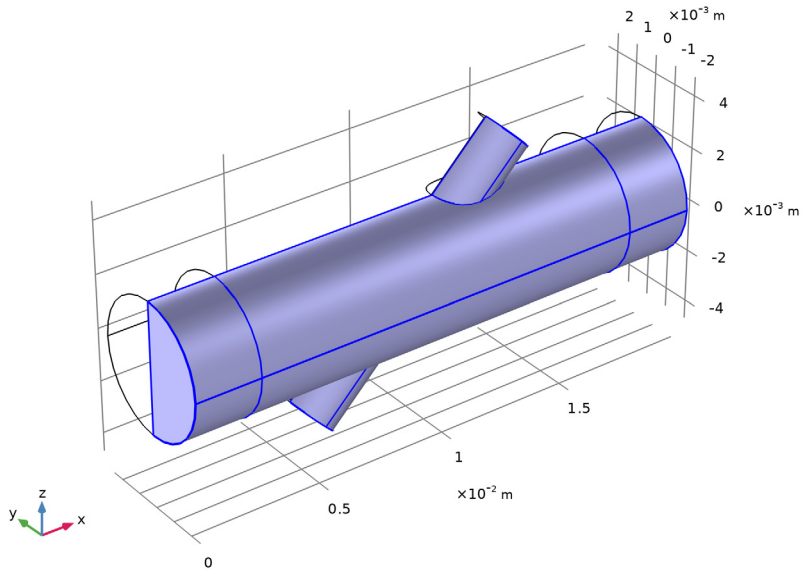

- 1 In the **Model Builder** window, right-click **Geometry 1** and choose **Delete Entities**.
Switch to wireframe rendering to more easily see the domains inside the model, when selecting.

- 2 Click the  **Wireframe Rendering** button in the **Graphics** toolbar.
- 3 In the **Settings** window for **Delete Entities**, locate the **Entities or Objects to Delete** section.
- 4 From the **Geometric entity level** list, choose **Domain**.
- 5 On the object **par1**, select Domains 1, 3, 5, 7, 9, and 11 only.



- 6 Click  **Build All Objects**.

Form Composite Domains 1 (cmd1)

- 1 In the **Geometry** toolbar, click  **Virtual Operations** and choose **Form Composite Domains**.
- 2 On the object **fin**, select Domains 2–5 only.
- 3 In the **Geometry** toolbar, click  **Build All**.
The geometry should look like [Figure 1](#).

ADD MATERIAL

- 1 In the **Materials** toolbar, click  **Add Material** to open the **Add Material** window.
- 2 Go to the **Add Material** window.
- 3 In the tree, select **Built-in > Water, liquid**.
- 4 Click the **Add to Component** button in the window toolbar.

- 5 In the **Materials** toolbar, click  **Add Material** to close the **Add Material** window.

DEFINITIONS

Symmetry

- 1 In the **Definitions** toolbar, click  **Explicit**.
- 2 In the **Settings** window for **Explicit**, locate the **Input Entities** section.
- 3 From the **Geometric entity level** list, choose **Boundary**.
- 4 Select Boundaries 2, 6, and 16 only.
- 5 In the **Label** text field, type Symmetry.

Flow Inlet

- 1 In the **Definitions** toolbar, click  **Explicit**.
- 2 In the **Settings** window for **Explicit**, type Flow Inlet in the **Label** text field.
- 3 Locate the **Input Entities** section. From the **Geometric entity level** list, choose **Boundary**.
- 4 Select Boundary 1 only.

Flow Outlet

- 1 In the **Definitions** toolbar, click  **Explicit**.
- 2 In the **Settings** window for **Explicit**, type Flow Outlet in the **Label** text field.
- 3 Locate the **Input Entities** section. From the **Geometric entity level** list, choose **Boundary**.
- 4 Select Boundary 19 only.

Source

- 1 In the **Definitions** toolbar, click  **Explicit**.
- 2 In the **Settings** window for **Explicit**, type Source in the **Label** text field.
- 3 Locate the **Input Entities** section. From the **Geometric entity level** list, choose **Boundary**.
- 4 Select Boundary 10 only.

Receiver

- 1 In the **Definitions** toolbar, click  **Explicit**.
- 2 In the **Settings** window for **Explicit**, type Receiver in the **Label** text field.
- 3 Locate the **Input Entities** section. From the **Geometric entity level** list, choose **Boundary**.
- 4 Select Boundary 14 only.

Walls

- 1 In the **Definitions** toolbar, click  **Explicit**.

- 2 In the **Settings** window for **Explicit**, type Walls in the **Label** text field.
- 3 Locate the **Input Entities** section. From the **Geometric entity level** list, choose **Boundary**.
- 4 Select Boundaries 3, 4, 7–9, 11–13, 17, and 18 only.

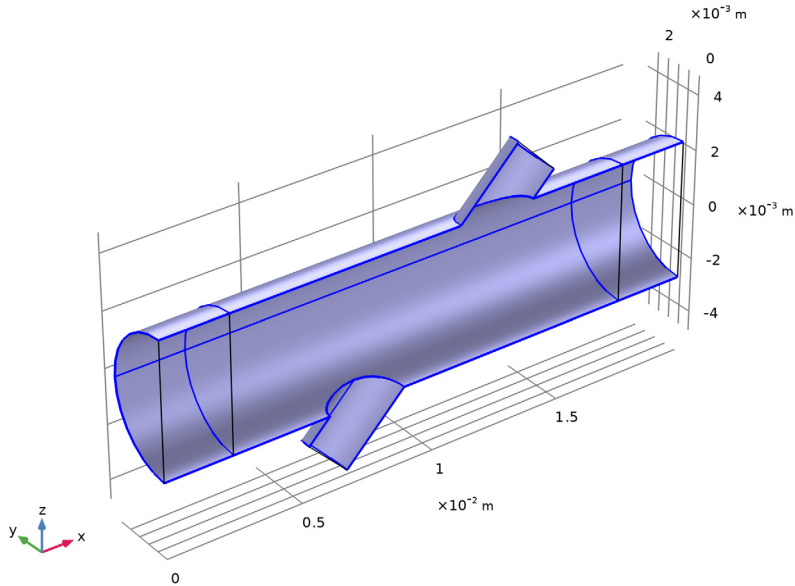

TURBULENT FLOW, K- ω (SPF)

Inlet /

- 1 In the **Physics** toolbar, click  **Boundaries** and choose **Inlet**.
- 2 In the **Settings** window for **Inlet**, locate the **Boundary Selection** section.
- 3 From the **Selection** list, choose **Flow Inlet**.
- 4 Locate the **Boundary Condition** section. From the list, choose **Fully developed flow**.
- 5 Locate the **Fully Developed Flow** section. In the U_{av} text field, type U_{in} .
This boundary condition ensures a fully developed turbulent flow profile at the inlet.

Outlet /

- 1 In the **Physics** toolbar, click  **Boundaries** and choose **Outlet**.
- 2 In the **Settings** window for **Outlet**, locate the **Boundary Selection** section.
- 3 From the **Selection** list, choose **Flow Outlet**.

Symmetry 1

- 1 In the **Physics** toolbar, click  **Boundaries** and choose **Symmetry**.
- 2 In the **Settings** window for **Symmetry**, locate the **Boundary Selection** section.
- 3 From the **Selection** list, choose **Symmetry**.

MESH - CFD

- 1 In the **Model Builder** window, under **Component 1 (comp1)** click **Mesh 1**.
- 2 In the **Settings** window for **Mesh**, type Mesh - CFD in the **Label** text field.
- 3 Right-click **Component 1 (comp1)** > **Mesh - CFD** and choose **Edit Physics-Induced Sequence**.



Free Tetrahedral 1

- 1 In the **Model Builder** window, under **Component 1 (comp1)** > **Mesh - CFD** click **Free Tetrahedral 1**.
- 2 In the **Settings** window for **Free Tetrahedral**, locate the **Domain Selection** section.
- 3 From the **Geometric entity level** list, choose **Domain**.
- 4 Select Domain 2 only.

Swept 1

- 1 In the **Mesh** toolbar, click  **Swept**.
- 2 Drag and drop below **Free Tetrahedral 1**.



Distribution 1

- 1 Right-click **Swept 1** and choose **Distribution**.
- 2 In the **Settings** window for **Distribution**, locate the **Distribution** section.
- 3 In the **Number of elements** text field, type 12.
- 4 Click  **Build All**.
- 5 Click  **Build All**.

STUDY 1 - CFD

- 1 In the **Model Builder** window, click **Study 1**.
- 2 In the **Settings** window for **Study**, type Study 1 - CFD in the **Label** text field.
- 3 Locate the **Study Settings** section. Clear the **Generate default plots** checkbox.
Compute the flow solution.
- 4 In the **Study** toolbar, click  **Compute**.

ADD PHYSICS

- 1 In the **Home** toolbar, click  **Add Physics** to open the **Add Physics** window.
- 2 Go to the **Add Physics** window.
- 3 In the tree, select **Acoustics** > **Ultrasound** > **Convected Wave Equation, Time Explicit (cwe)**.
- 4 Find the **Physics interfaces in study** subsection. In the table, clear the **Solve** checkbox for **Study 1 - CFD**.
- 5 Click the **Add to Component 1** button in the window toolbar.
- 6 In the **Home** toolbar, click  **Add Physics** to close the **Add Physics** window.

CONVECTED WAVE EQUATION, TIME EXPLICIT (CWE)

- 1 Click the  **Show More Options** button in the **Model Builder** toolbar.
- 2 In the **Show More Options** dialog, in the tree, select the checkbox for the node **Physics** > **Advanced Physics Options**.
- 3 Click **OK**.

Symmetry 1

- 1 In the **Physics** toolbar, click  **Boundaries** and choose **Symmetry**.
- 2 In the **Settings** window for **Symmetry**, locate the **Boundary Selection** section.
- 3 From the **Selection** list, choose **Symmetry**.

Specific Acoustic Impedance (Isentropic) 1

- 1 In the **Physics** toolbar, click  **Boundaries** and choose **Specific Acoustic Impedance (Isentropic)**.
- 2 Select Boundaries 1 and 19 only.

Define the driving signal as given in [Equation 1](#).

GLOBAL DEFINITIONS

Analytic 1 (an1)

- 1 In the **Home** toolbar, click  **Functions** and choose **Global** > **Analytic**.
- 2 In the **Settings** window for **Analytic**, type v_n in the **Function name** text field.
- 3 Locate the **Definition** section. In the **Expression** text field, type $A*\sin(\omega_0*t)*\exp(-(f_0*(t-3*T_0))^2)$.
- 4 In the **Arguments** text field, type t .

5 Locate the **Units** section. In the table, enter the following settings:

Argument	Unit
t	s

6 In the **Function** text field, type m/s.

CONVECTED WAVE EQUATION, TIME EXPLICIT (CWE)

Normal Velocity I

- 1 In the **Physics** toolbar, click  **Boundaries** and choose **Normal Velocity**.
- 2 In the **Settings** window for **Normal Velocity**, locate the **Boundary Selection** section.
- 3 From the **Selection** list, choose **Source**.
- 4 Locate the **Normal Velocity** section. In the $v_n(t)$ text field, type $v_n(t)$.

Create a nonlocal average coupling to be used in postprocessing to calculate the average pressure at the receiver.

DEFINITIONS

Average I (aveopI)

- 1 In the **Definitions** toolbar, click  **Nonlocal Couplings** and choose **Average**.
- 2 In the **Settings** window for **Average**, locate the **Source Selection** section.
- 3 From the **Geometric entity level** list, choose **Boundary**.
- 4 From the **Selection** list, choose **Receiver**.

Now, set up the absorbing layers (sponge layers) used to truncate the computational domain.

Absorbing Layer I (abl)

- 1 In the **Definitions** toolbar, click  **Absorbing Layer**.
- 2 Select Domains 1 and 3 only.

The turbulent flow interface uses linear discretization for the dependent variables. This affects the order of the geometry shape approximation which is by default the same as the discretization order chosen in the first physics interface present in the model tree. On the other hand, a higher order discretization (quartic per default) is used for the acoustics simulation. The mismatch between the geometry and the dependent variables discretization can cause instabilities in the solution. Therefore, it is recommended that you

manually increase the geometry shape approximation order to **Quadratic Lagrange**. Note that, if this change is not done a warning message is given when solving the model.



COMPONENT 1 (COMP1)

- 1 In the **Model Builder** window, click **Component 1 (comp1)**.
- 2 In the **Settings** window for **Component**, locate the **Curved Mesh Elements** section.
- 3 From the **Geometry shape function** list, choose **Quadratic Lagrange**.

Create an interpolation function and import data for a signal moving the opposite way (upstream) to the signal modeled here (downstream). You will use that data in postprocessing. The data was generated by switching the source and receiver selections and running the model.

GLOBAL DEFINITIONS

Interpolation 1 (int1)

- 1 In the **Home** toolbar, click  **Functions** and choose **Global > Interpolation**.
- 2 In the **Settings** window for **Interpolation**, locate the **Definition** section.
- 3 From the **Data source** list, choose **File**.
- 4 Click  **Browse**.
- 5 Browse to the model's Application Libraries folder and double-click the file `ultrasound_flow_meter_generic_upstream_signal.txt`.
If you want to import the data into the model, and not rely on the .txt file, click **Import**.
- 6 Locate the **Data Column Settings** section. In the table, click to select the cell at row number 1 and column number 1.
- 7 In the **Unit** text field, type `s`.
- 8 In the table, click to select the cell at row number 2 and column number 1.
- 9 In the **Name** text field, type `p_upstream`.
- 10 In the **Unit** text field, type `Pa`.
- 11 Locate the **Interpolation and Extrapolation** section. From the **Interpolation** list, choose **Piecewise cubic**.

Create the acoustics mesh. In contrast to the CFD mesh, this mesh can be relatively coarse.

MESH - ACOUSTICS

- 1 In the **Mesh** toolbar, click **Add Mesh** and choose **Add Mesh**.
- 2 In the **Settings** window for **Mesh**, type `Mesh - Acoustics` in the **Label** text field.

Free Tetrahedral I

In the **Mesh** toolbar, click  **Free Tetrahedral**.

Size

- 1** In the **Model Builder** window, click **Size**.
- 2** In the **Settings** window for **Size**, locate the **Element Size** section.
- 3** Click the **Custom** button.
- 4** Locate the **Element Size Parameters** section. In the **Maximum element size** text field, type $1\lambda_0/1.5$.
- 5** In the **Minimum element size** text field, type $1\lambda_0/2$.

With this setting you get a bit more than 1.5 elements per wavelength at the frequency f_0 . This may need to be increased to, for example, $1\lambda_0/2$ in order to well resolve the small frequency content above f_0 , that exists in the Gaussian pulse.

Free Tetrahedral I

When modeling using physics interfaces that are based on the DG method, it is important to avoid small mesh elements, since they control the time steps taken by the solver. In order to avoid this use the **Element Quality Optimization** functionality available for the tetrahedral mesh. This step is very important.

- 1** In the **Model Builder** window, click **Free Tetrahedral I**.
- 2** In the **Settings** window for **Free Tetrahedral**, click to expand the **Element Quality Optimization** section.
- 3** Select the **Avoid elements that are too small** checkbox.
- 4** From the **Optimization level** list, choose **High**.

5 Click  **Build All**.

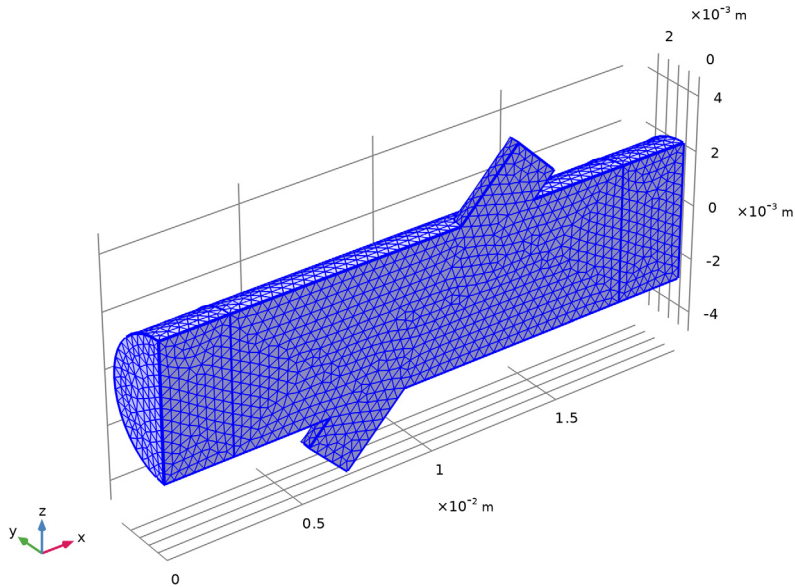

An important part of solving aeroacoustic problems is to correctly map the CFD solution onto the acoustics domain. This is done using the built-in **Background Fluid Flow Coupling** multiphysics feature and the dedicated **Mapping** study.

MULTIPHYSICS

Background Fluid Flow Coupling 1 (bffc1)

- 1 In the **Physics** toolbar, click  **Multiphysics Couplings** and choose **Domain > Background Fluid Flow Coupling**.
- 2 In the **Settings** window for **Background Fluid Flow Coupling**, locate the **Domain Selection** section.
- 3 From the **Selection** list, choose **All domains**.
- 4 Locate the **Smoothing** section. In the **Diffusion constant** text field, type $1e-4$.

Return to the **Convected Wave Equation Model** node and see that the background mean flow pressure and velocity automatically take the corresponding mapped quantities.

ADD STUDY

- 1 In the **Home** toolbar, click  **Add Study** to open the **Add Study** window.
- 2 Go to the **Add Study** window.

- 3 Find the **Physics interfaces in study** subsection. In the table, clear the **Solve** checkboxes for **Turbulent Flow, k- ω (spf)** and **Convected Wave Equation, Time Explicit (cwe)**.
- 4 Find the **Studies** subsection. In the **Select Study** tree, select **Preset Studies for Selected Multiphysics > Mapping**.
- 5 Click the **Add Study** button in the window toolbar.

STUDY 2 - MAPPING

- 1 In the **Settings** window for **Study**, type Study 2 - Mapping in the **Label** text field.
- 2 Locate the **Study Settings** section. Clear the **Generate default plots** checkbox.

Step 1: Mapping

- 1 In the **Model Builder** window, under **Study 2 - Mapping** click **Step 1: Mapping**.
- 2 In the **Settings** window for **Mapping**, locate the **Data to Map** section.
- 3 From the **Source** list, choose **Study 1 - CFD, Stationary**.
Make sure that the acoustic mesh is chosen for mapping the CFD solution upon.
- 4 Click to expand the **Destination Mesh Selection** section. In the **Study** toolbar, click  **Compute**.

ADD STUDY

- 1 Go to the **Add Study** window.
- 2 Find the **Physics interfaces in study** subsection. In the table, clear the **Solve** checkbox for **Turbulent Flow, k- ω (spf)**.
- 3 Find the **Multiphysics couplings in study** subsection. In the table, clear the **Solve** checkbox for **Background Fluid Flow Coupling I (bffc1)**.
- 4 Find the **Studies** subsection. In the **Select Study** tree, select **General Studies > Time Dependent**.
- 5 Click the **Add Study** button in the window toolbar.
- 6 In the **Study** toolbar, click  **Add Study** to close the **Add Study** window.

STUDY - ACOUSTICS

- 1 In the **Settings** window for **Study**, type Study - Acoustics in the **Label** text field.
- 2 Locate the **Study Settings** section. Clear the **Generate default plots** checkbox.

Step 1: Time Dependent

- 1 In the **Model Builder** window, under **Study - Acoustics** click **Step 1: Time Dependent**.
- 2 In the **Settings** window for **Time Dependent**, locate the **Study Settings** section.

3 In the **Output times** text field, type range (0, T0/12, 30*T0).

This setting saves the solution 12 times per period and runs the model for 30 periods. The setting only influences when to store the solution (and thus the file size). The internal time steps taken by the solver are automatically controlled by COMSOL to fulfill the appropriate CFL condition.

4 Click to expand the **Values of Dependent Variables** section. Find the **Values of variables not solved for** subsection. From the **Settings** list, choose **User controlled**.

5 From the **Method** list, choose **Solution**.

6 From the **Study** list, choose **Study 2 - Mapping, Mapping**.

7 Click to expand the **Store in Output** section. In the table, enter the following settings:

Interface	Output
Turbulent Flow, k- ω (spf)	Selection

8 Click to select row number 1 in the table.

9 Under **Selections**, click **+ Add**.

10 In the **Add** dialog, in the **Selections** list, choose **Symmetry, Source, and Receiver**.

11 Click **OK**.

12 In the **Settings** window for **Time Dependent**, locate the **Store in Output** section.

13 In the table, enter the following settings:

Interface	Output
Convected Wave Equation, Time Explicit (cwe)	Selection

14 Click to select row number 2 in the table.

15 Under **Selections**, click **+ Add**.

16 In the **Add** dialog, in the **Selections** list, choose **Symmetry, Source, and Receiver**.

17 Click **OK**.

The amount of data generated in this model is large. A good way to restrict the file size is to only store the data on desired selections. Here the solution is only stored on the symmetry plane, and on the source and receiver faces.

Check that the correct mesh is used for the transient acoustic simulation.

18 In the **Settings** window for **Time Dependent**, click to expand the **Mesh Selection** section.

Now solve the convected wave equation (acoustics) model.

19 In the **Study** toolbar, click  **Compute**.

Before generating any plots and looking at results, process the datasets. It is good practice to add the same selections to the result dataset as the selections chosen in the **Store in Output**. For postprocessing purposes only select the symmetry plane, source, and receiver in the Acoustics dataset (not selecting the absorbing layer).

RESULTS

In the **Model Builder** window, expand the **Results** node.

Study - Acoustics/Solution 3 (sol3)

In the **Model Builder** window, expand the **Results > Datasets** node, then click **Study - Acoustics/Solution 3 (sol3)**.

Selection

- 1 In the **Results** toolbar, click  **Attributes** and choose **Selection**.
- 2 In the **Settings** window for **Selection**, locate the **Geometric Entity Selection** section.
- 3 From the **Geometric entity level** list, choose **Boundary**.
- 4 Select Boundaries 6, 10, and 14 only.

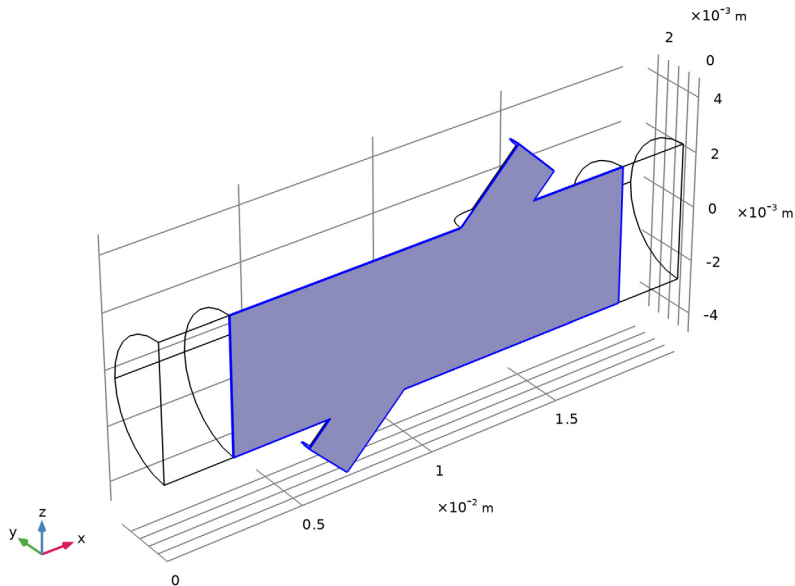

Finally, create a dataset that is a cut line following the axis of the transducer duct.

Cut Line 3D 1

- 1 In the **Results** toolbar, click  **Cut Line 3D**.
- 2 In the **Settings** window for **Cut Line 3D**, locate the **Data** section.
- 3 From the **Dataset** list, choose **Study - Acoustics/Solution 3 (sol3)**.
- 4 Locate the **Line Data** section. From the **Line entry method** list, choose **Point and direction**.
- 5 Find the **Point** subsection. In the **x** text field, type $L/2$.
- 6 Find the **Direction** subsection. In the **x** text field, type nLx .
- 7 In the **y** text field, type nLy .
- 8 In the **z** text field, type nLz .
- 9 From the **Snapping** list, choose **Snap to closest boundary**.

In the following postprocessing the **Resolution** is increased under the **Quality** section in all acoustics plots. This is because the shape functions used for the convected wave equation interface are 4th order per default. So in order to properly represent the solution, the resolution needs to be increased.

Background Flow Velocity

- 1 In the **Results** toolbar, click  **3D Plot Group**.
- 2 In the **Settings** window for **3D Plot Group**, type Background Flow Velocity in the **Label** text field.
- 3 Locate the **Color Legend** section. Select the **Show units** checkbox.

Surface 1

- 1 Right-click **Background Flow Velocity** and choose **Surface**.
- 2 In the **Background Flow Velocity** toolbar, click  **Plot**.

The background mean flow velocity amplitude plotted on the surface of the geometry should look like [Figure 2](#).

Background Flow Velocity Profile

- 1 In the **Results** toolbar, click  **ID Plot Group**.
- 2 In the **Settings** window for **ID Plot Group**, type Background Flow Velocity Profile in the **Label** text field.

Line Graph 1

- 1 Right-click **Background Flow Velocity Profile** and choose **Line Graph**.
- 2 Select Edge 7 only.

- 3 In the **Settings** window for **Line Graph**, locate the **x-Axis Data** section.
- 4 From the **Parameter** list, choose **Expression**.
- 5 In the **Expression** text field, type **z**.
- 6 Click to expand the **Legends** section. Select the **Show legends** checkbox.
- 7 From the **Legends** list, choose **Manual**.
- 8 In the table, enter the following settings:

Legends
Mean flow profile, CFD

Line Graph 2

- 1 Right-click **Line Graph 1** and choose **Duplicate**.
- 2 In the **Settings** window for **Line Graph**, locate the **Data** section.
- 3 From the **Dataset** list, choose **Study 2 - Mapping/Solution 2 (sol2)**.
- 4 Click **Replace Expression** in the upper-right corner of the **y-Axis Data** section. From the menu, choose **Component 1 (comp1) > Background Fluid Flow Coupling 1 > Mapped velocity - m/s > bffcl.u_mapx - Mapped velocity, x-component**.
- 5 Locate the **Legends** section. In the table, enter the following settings:

Legends
Mean flow profile, Mapped

- 6 In the **Background Flow Velocity Profile** toolbar, click  **Plot**.

The CFD and the mapped background mean flow profiles are depicted in [Figure 3](#).

Acoustic Pressure

- 1 In the **Results** toolbar, click  **3D Plot Group**.
- 2 In the **Settings** window for **3D Plot Group**, type **Acoustic Pressure** in the **Label** text field.
- 3 Locate the **Data** section. From the **Dataset** list, choose **Study - Acoustics/Solution 3 (sol3)**.
- 4 Locate the **Color Legend** section. Select the **Show units** checkbox.

Surface 1

- 1 Right-click **Acoustic Pressure** and choose **Surface**.
- 2 In the **Settings** window for **Surface**, locate the **Expression** section.
- 3 In the **Expression** text field, type **p2**.
- 4 Locate the **Coloring and Style** section. From the **Color table** list, choose **Wave**.

- 5 From the **Scale** list, choose **Linear symmetric**.
- 6 Click to expand the **Quality** section. From the **Evaluation settings** list, choose **Manual**.
- 7 From the **Resolution** list, choose **Custom**.
- 8 In the **Element refinement** text field, type 6.
- 9 In the **Acoustic Pressure** toolbar, click  **Plot**.

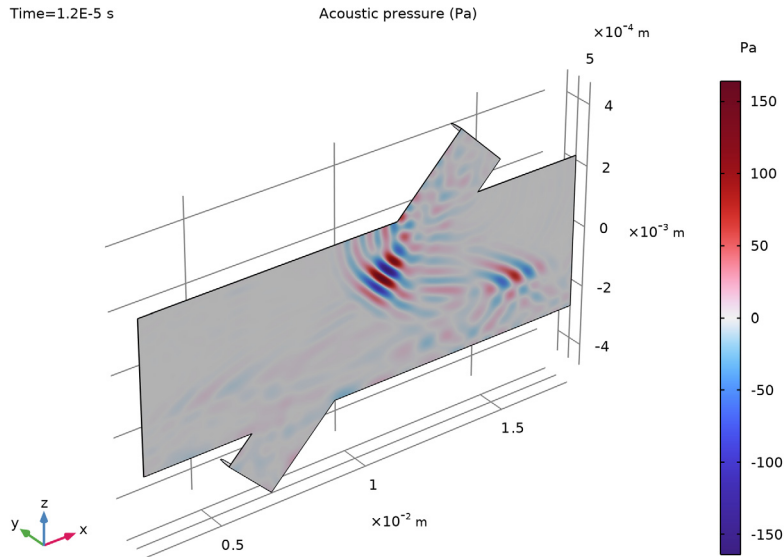

Add a deformation to better visualize the nature of the waves propagating in the symmetry plane.

Deformation 1

Right-click **Surface 1** and choose **Deformation**.

Deformation 1

- 1 In the **Model Builder** window, expand the **Results > Acoustic Pressure > Surface 1** node, then click **Deformation 1**.
- 2 In the **Settings** window for **Deformation**, locate the **Expression** section.
- 3 In the **x-component** text field, type 0.
- 4 In the **y-component** text field, type p2.
- 5 In the **z-component** text field, type 0.

- 6 In the **Acoustic Pressure** toolbar, click  **Plot**.

The first plot that is shown is for the last stored time, at $30 \cdot T_0$. Change the **Time** selection to see the solution at other instances. Some are shown in [Figure 4](#).

Alternatively, create an animation (under the **Export** node) that shows the time dependent evolution of the pulse.

Acoustic Pressure

- 1 In the **Model Builder** window, under **Results** click **Acoustic Pressure**.
- 2 In the **Settings** window for **3D Plot Group**, locate the **Data** section.
- 3 From the **Time (s)** list, choose **2E-6**.
- 4 In the **Acoustic Pressure** toolbar, click  **Plot**.

Acoustic Velocity

- 1 In the **Results** toolbar, click  **3D Plot Group**.
- 2 In the **Settings** window for **3D Plot Group**, type **Acoustic Velocity** in the **Label** text field.
- 3 Locate the **Data** section. From the **Dataset** list, choose **Study - Acoustics/Solution 3 (sol3)**.
- 4 From the **Time (s)** list, choose **8E-6**.
- 5 Locate the **Color Legend** section. Select the **Show units** checkbox.

Surface 1

- 1 Right-click **Acoustic Velocity** and choose **Surface**.
- 2 In the **Settings** window for **Surface**, click **Replace Expression** in the upper-right corner of the **Expression** section. From the menu, choose **Component 1 (comp1) > Convected Wave Equation, Time Explicit > Acceleration and velocity > cwe.v_inst - Acoustic velocity amplitude - m/s**.
- 3 Locate the **Coloring and Style** section. From the **Scale** list, choose **Linear symmetric**.
- 4 Locate the **Quality** section. From the **Evaluation settings** list, choose **Manual**.
- 5 From the **Resolution** list, choose **Custom**.
- 6 In the **Element refinement** text field, type 6.
- 7 In the **Acoustic Velocity** toolbar, click  **Plot**.

The acoustic velocity amplitude is depicted in [Figure 5](#). Once again, change the **Time** selection to study the wave propagation.

Proceed to plot the instantaneous intensity as depicted in [Figure 6](#).

Acoustic Intensity

- 1 In the **Results** toolbar, click  **3D Plot Group**.
- 2 In the **Settings** window for **3D Plot Group**, type **Acoustic Intensity** in the **Label** text field.
- 3 Locate the **Data** section. From the **Dataset** list, choose **Study - Acoustics/Solution 3 (sol3)**.
- 4 From the **Time (s)** list, choose **8E-6**.
- 5 Locate the **Color Legend** section. Select the **Show units** checkbox.

Surface 1

- 1 Right-click **Acoustic Intensity** and choose **Surface**.
- 2 In the **Settings** window for **Surface**, click **Replace Expression** in the upper-right corner of the **Expression** section. From the menu, choose **Component 1 (comp1) > Convected Wave Equation, Time Explicit > Intensity > cwe.li_mag - Instantaneous intensity magnitude - W/m²**.
- 3 Locate the **Coloring and Style** section. From the **Color table** list, choose **ThermalDark**.
- 4 Locate the **Quality** section. From the **Evaluation settings** list, choose **Manual**.
- 5 From the **Resolution** list, choose **Custom**.
- 6 In the **Element refinement** text field, type 6.

Arrow Surface 1

- 1 In the **Model Builder** window, right-click **Acoustic Intensity** and choose **Arrow Surface**.
- 2 In the **Settings** window for **Arrow Surface**, click **Replace Expression** in the upper-right corner of the **Expression** section. From the menu, choose **Component 1 (comp1) > Convected Wave Equation, Time Explicit > Intensity > cwe.lix,...,cwe.liz - Instantaneous intensity**.
- 3 Locate the **Coloring and Style** section. From the **Arrow length** list, choose **Logarithmic**.
- 4 In the **Range quotient** text field, type 400.
- 5 Locate the **Arrow Positioning** section. In the **Number of arrows** text field, type 1000.
- 6 Locate the **Coloring and Style** section. From the **Color** list, choose **White**.
- 7 In the **Acoustic Intensity** toolbar, click  **Plot**.

Now, proceed to plot the pressure pulse along the central transducer duct axis in a 1D graph. The figure should look like [Figure 7](#).

Pressure Along Transducer Axis

- 1 In the **Results** toolbar, click  **1D Plot Group**.

- 2 In the **Settings** window for **ID Plot Group**, type Pressure Along Transducer Axis in the **Label** text field.
- 3 Locate the **Data** section. From the **Dataset** list, choose **Cut Line 3D 1**.
- 4 From the **Time selection** list, choose **From list**.
- 5 In the **Times (s)** list box, select **4E-6**.

Line Graph 1

- 1 Right-click **Pressure Along Transducer Axis** and choose **Line Graph**.
- 2 In the **Settings** window for **Line Graph**, locate the **y-Axis Data** section.
- 3 In the **Expression** text field, type p_2 .
- 4 Click to expand the **Quality** section. From the **Evaluation settings** list, choose **Manual**.
- 5 From the **Resolution** list, choose **Extra fine**.
- 6 In the **Pressure Along Transducer Axis** toolbar, click  **Plot**.

The final graph to create shows the average pressure signal at the receiver for the pulse moving downstream (the model simulated here). The figure also includes the pressure from a signal moving upstream, as taken from the imported data. After zooming, the graph should look like [Figure 8](#).

Pressure Signal at Receivers

- 1 In the **Results** toolbar, click  **ID Plot Group**.
- 2 In the **Settings** window for **ID Plot Group**, type Pressure Signal at Receivers in the **Label** text field.
- 3 Locate the **Data** section. From the **Dataset** list, choose **Study - Acoustics/Solution 3 (sol3)**.

Global 1

- 1 Right-click **Pressure Signal at Receivers** and choose **Global**.
- 2 In the **Settings** window for **Global**, locate the **y-Axis Data** section.
- 3 In the table, enter the following settings:

Expression	Unit	Description
aveop1(p2)	Pa	Pressure moving downstream
p_upstream(t)	Pa	Pressure moving upstream (imported)

4 In the **Pressure Signal at Receivers** toolbar, click  **Plot**.

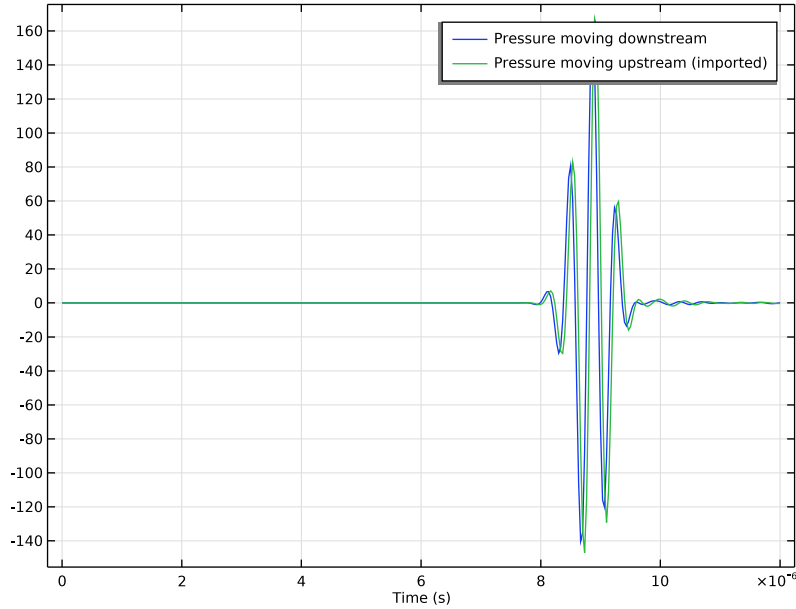

Finally, calculate the integral expression given in [Equation 3](#) under the **Derived Values** node. Here you can also calculate the predicted mean flow speeds from [Equation 2](#). The results are discussed in the main results section.

Line Integration 1

- 1 In the **Results** toolbar, click  **More Derived Values** and choose **Integration > Line Integration**.
- 2 In the **Settings** window for **Line Integration**, locate the **Data** section.
- 3 From the **Dataset** list, choose **Cut Line 3D 1**.
- 4 From the **Time selection** list, choose **First**.
- 5 Locate the **Expressions** section. In the table, enter the following settings:

Expression	Unit	Description
$1 / (cwe . c0 - (nLx * cwe . u0x + nLy * cwe . u0y + nLz * cwe . u0z)) - 1 / (cwe . c0 + (nLx * cwe . u0x + nLy * cwe . u0y + nLz * cwe . u0z))$		

- 6 Click  **Evaluate**.

Global Evaluation 1

- 1 In the **Results** toolbar, click  **Global Evaluation**.
- 2 In the **Settings** window for **Global Evaluation**, locate the **Data** section.
- 3 From the **Dataset** list, choose **Study - Acoustics/Solution 3 (sol3)**.
- 4 From the **Time selection** list, choose **First**.
- 5 Locate the **Expressions** section. In the table, enter the following settings:

Expression	Unit	Description
$L2/(DT_calc*\cos(\alpha))*(-1+\sqrt{1+DT_calc^2*c0^2/L2^2})$		
$L2/(DT_simulated*\cos(\alpha))*(-1+\sqrt{1+DT_simulated^2*c0^2/L2^2})$		

- 6 Click  **Evaluate**.