



Model created in COMSOL Multiphysics 6.4

# Piezoelectric Tonpilz Transducer

## Introduction

---

The tonpiliz (sound mushroom) transducer is a transducer for relatively low frequency, high power sound emission (Ref. 1 and Ref. 2). It is one of the popular acoustic transducer designs that are used for underwater sonar applications. The tonpiliz transducer modeled in this tutorial consists of piezoceramic rings stacked between an aluminum head mass and a steel tail mass connected by a steel bolt. This central bolt could be prestressed to control the transducer response. The tail and head mass are used to lower the resonance frequency of the device to the desired level.

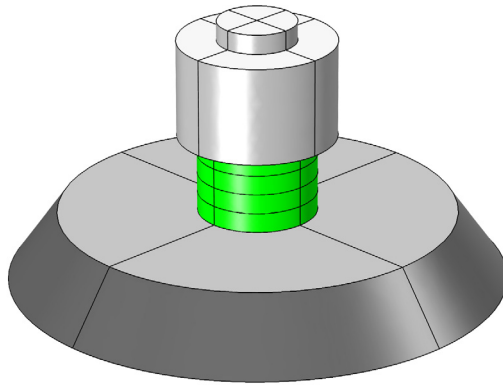

*Figure 1: A tonpiliz transducer. The aluminum head mass is shown in dark gray, the central steel bolt and steel tail mass are shown in light gray and the piezostack actuator with four disks of PZT-4 is shown in green.*

## Model Definition

---

In this model, the frequency response of the transducer shown in Figure 1 is studied. In this version of the tutorial, the effect of prestress in the bolt is not considered. The outer curved surface of the steel tail mass is assumed to be fixed. Each of the piezo disks are excited with a 1 V RMS electrical signal. The model determines the deformation in the device, the radiated pressure field and sound pressure level, as well as the spatial radiation pattern sensitivity, the transmitting voltage response (TVR) curve of the transducer, and the directivity index (DI) of the sound beam within the frequency range of 1 kHz to 40 kHz.

The parameters used in this model are shown in Table 1.

TABLE 1: LIST OF MODELING PARAMETERS.

NAME	EXPRESSION	DESCRIPTION
Rwater	40[mm]	Water domain radius
Rpml	10[mm]	PML layer thickness
a	25[mm]	Piston head radius
Zeval	-10[m]	Directivity evaluation distance
Vrms	1[V]	RMS drive voltage
V0	$\text{sqrt}(2)*V_{\text{rms}}$	Zero-to-peak drive voltage
f0min	1[kHz]	Minimum operating frequency
f0max	40[kHz]	Maximum operating frequency
f0step	1[kHz]	Frequency step

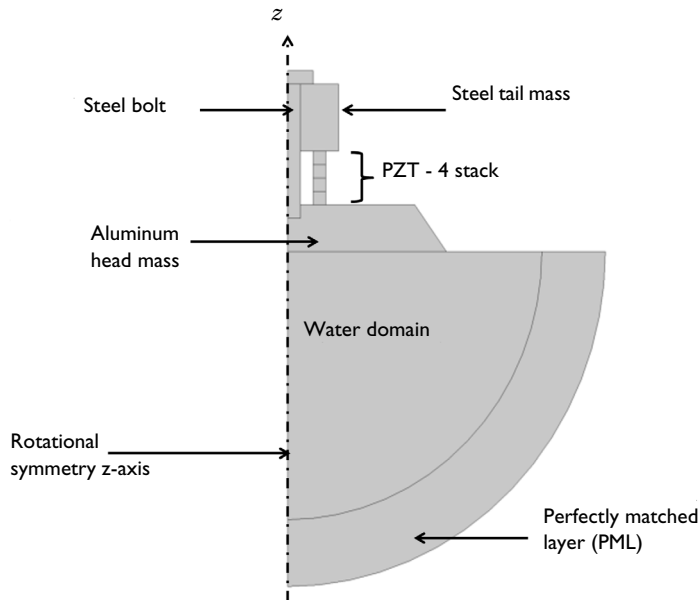

Figure 2: An axisymmetric section of the model geometry.

Figure 2 shows an axisymmetric view of the actual 3D model. The head mass is exposed to an unbounded region of water. A perfectly matched layer (PML) is used to model the absorption of sound waves as they propagate far away from the sound source. Note that

although the modeling geometry has a rotational symmetry, using a full 3D geometry allows us to capture any vibration mode of the transducer and acoustic mode of the fluid region that do not possess such a symmetry in the solution.

#### **PHYSICS IMPLEMENTATION**

The Acoustic–Piezoelectric Interaction, Frequency Domain interface available in the Acoustics Module is used to simulate the multiphysics interactions. This predefined multiphysics interface includes the necessary fundamental physics which are Pressure Acoustics, Solid Mechanics, and Electrostatics. The Pressure Acoustics interface is used to solve the wave equation in the water domain. The Solid Mechanics interface is solved on all structural materials including the PZT-4 disks. The Electrostatics interface is solved on the PZT-4 disks. The multiphysics couplings necessary to model this system are available as predefined nodes under the Multiphysics branch. These couplings are:

*Acoustic–Structure Boundary:* This node is active on the boundaries that are at the interface of the water domain and transducer head mass. On these boundaries a bidirectional coupling is automatically set up. The fluid pressure evaluated by the Pressure Acoustics interface is applied as a mechanical load in the Solid Mechanics interface. Furthermore, the normal component of the structural acceleration is used as a sound source.

*Piezoelectricity:* This node is active on the PZT-4 domains only and couple the Solid Mechanics and Electrostatics equations solved in these domains via the linear constitutive equations that model the piezoelectric effect by coupling stresses and strains with electric field and electric displacement.

#### **MATERIAL ORIENTATION**

The piezoelectric disks are stacked in a way such that alternate disks are poled along opposite directions as shown in [Figure 3](#). This allows us to use a single electrical terminal at the interface of each pair of disks and obtain the piezoelectric actuation effect in each of

the disks along the same direction. Having the piezoelectric strain in-phase in all the disks maximizes the actuation.

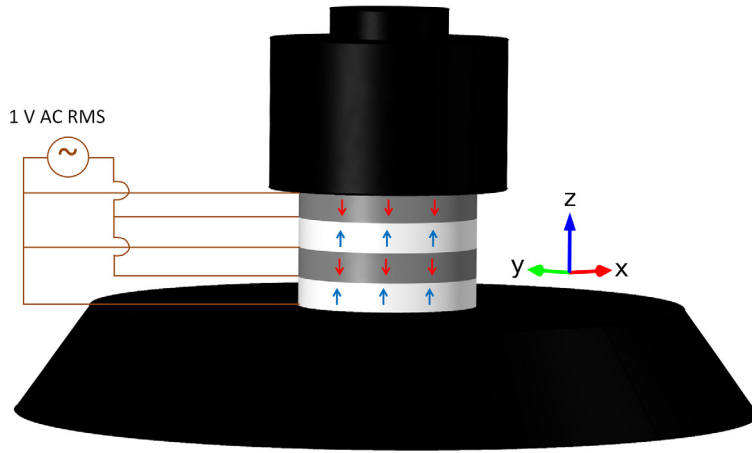

*Figure 3: Schematic representation of the poling direction and electrical connections in the piezo disks. The blue arrows in the light gray disks indicate a +Z polarization. The red arrows in the dark gray disks indicate a -Z polarization.*

In this model, the PZT-4 disks actuate in the  $d_{33}$ -mode. Hence, two of the disks are poled along the +Z direction while the other two are poled along the -Z direction. The default definition of the piezoelectric material properties in the Global Coordinate System automatically creates a +Z polarization. In order to create a -Z polarization, a user-defined Rotated Coordinate System is used. In this coordinate system, the Euler angles are set to  $\alpha = 0$ ,  $\beta = \pi$ , and  $\gamma = 0$ . Note that the COMSOL Multiphysics software uses the Z-X-Z convention for Euler angles.

### EXTERIOR FIELD CALCULATION

An exterior field calculation is set up on the interface boundaries between the inner water domain and the PML domains. The exterior-field integral type is set to *full integral* which allows computation of both amplitude and phase of the acoustic pressure and sound pressure level (SPL) at any point in space outside the computational domain. These quantities are later used in postprocessing to plot the on-axis pressure variation outside the computational domain as well as to visualize the beam pattern in 2D and 3D polar plots.

### MESHING CONSIDERATIONS

In order to accurately resolve the pressure waves within the inner water domain, the maximum mesh element size is specified as  $1/6^{\text{th}}$  of the smallest wavelength of interest.

The smallest wavelength is the speed of sound in water (1500 m/s) divided by the largest frequency used in the frequency sweep. The PML is meshed using the Swept feature to create five layers of structured mesh. Additionally a single layer of Boundary Layer Mesh is created within the inner water domain adjacent to the exterior field boundaries. The thickness of this layer is set to  $1/120^{\text{th}}$  of the smallest wavelength of interest. The single boundary layer creates a smooth transition between the inner free tetrahedral mesh and the outer structured prism mesh elements thereby yielding a more precise exterior field calculation.

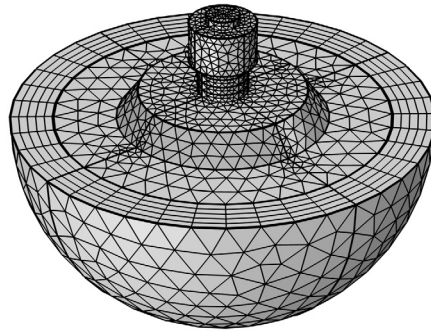

*Figure 4: The modeling geometry with the computational mesh.*

### **COMPUTING TRANSDUCER CHARACTERISTICS**

The frequency response of the following important transducer characteristics are investigated in this tutorial.

#### *Specific Acoustic Impedance*

The specific acoustic impedance  $Z_{\text{aco}}$  is computed as the ratio of the impedance of the head mass surface exposed to water to the characteristic impedance  $Z_0$  of water as shown in [Equation 1](#). The value of  $Z_0$  is computed from the product of density and speed of sound in water at a temperature of 293.15 K.

$$Z_{\text{aco}} = \frac{\left( \int_A p da \right) / \left( \int_A v_n da \right)}{Z_0} \quad (1)$$

The impedance of the head mass surface is computed from the ratio of the area integral of the acoustic pressure  $p$  to the area integral of the normal component of the structural velocity  $v_n$  of the surface. In this case, the normal velocity is the same as the  $Z$ -component of the velocity  $v_z$  which in frequency domain can be represented as the product of the  $Z$ -component of the structural displacement  $w$ , the variable  $j$  which is the imaginary number square root of  $-1$  and the angular frequency of vibration  $\omega$ . The area integral is computed by introducing a nonlocal integration coupling that is assigned to the surface of interest. To avoid division by zero, it is advised to add the built-in constant `eps`, which denotes the machine precision limit, to the variable  $w$  as shown in [Table 2](#) in the definition of the variable  $Z_{\text{aco}}$ .

#### *Transmitting Voltage Response (TVR)*

The TVR represents the sensitivity of the transducer measured at a distance of 1 m and driven at 1 V RMS. This definition can be mathematically expressed using [Equation 2](#).

$$TVR = 20 \log \frac{P_{\text{RMS}} / V_{\text{RMS}}}{1 \mu Pa V^{-1}} \quad (2)$$

The RMS pressure at 1 m from the transducer head mass surface can be computed from [Equation 3](#).

$$P_{\text{RMS}} = \sqrt{\frac{1}{2} p p^*} \quad (3)$$

In [Equation 3](#), the pressure  $p$  at 1 m ahead of the transducer is obtained using the exterior field pressure variable `pext` by using an expression `pext(0,0,-1)`. Note that the computational domain is much smaller than 1 m but by performing the exterior field calculation you are able to compute the pressure and phase at any point outside the domain. The variable  $p^*$  is the complex conjugate of the pressure  $p$  and can be expressed in COMSOL using the expression `conj(pext(0,0,-1))`.

#### *Directivity Index (DI)*

The directivity index (DI) gives a measure of how directional the transmitted acoustic beam is ([Ref. 3](#)). It is a measure of the ratio of the intensity  $I_{\text{front}}$  in front of the transducer at a certain distance in the far-field (beyond the Rayleigh radius) to the intensity  $I_{\text{ave}}$  transmitted by an omnidirectional source of the same strength. The DI is evaluated at a

distance of 10 m in front of the transducer. You can alter the value of the parameter  $Z_{eval}$  to compute the DI at a different location. The DI can be computed from [Equation 4](#).

$$DI = 10 \log \frac{I_{front}}{I_{ave}} \quad (4)$$

The quantity  $I_{front}$  can be computed from the ratio of the RMS pressure at the desired distance from the transducer to the characteristic impedance  $Z_0$ . The quantity  $I_{ave}$  can be computed from the ratio of total radiated power  $P_{tot}$ , to the surface area of a sphere having the same radius as the distance from the transducer at which the DI is computed.

The user-defined variables used to compute the transducer characteristics are shown in [Table 2](#).

TABLE 2: LIST OF VARIABLES.

NAME	EXPRESSION	DESCRIPTION
rho0	intop3(acpr.rho)	Density of water at room temperature
c0	intop3(acpr.c)	Speed of sound in water at room temperature
Zaco	intop2(p)/intop2(acpr.iomega*(w+eps))/(rho0*c0)	Specific acoustic impedance
pext_l	pext(0,0,-l)	Exterior field pressure at l m
prms	sqrt(0.5*pext_l*conj(pext_l))[Pa]	RMS pressure at l m
TVR	20*log10(prms/Vrms/l[uPa/V])	Transmitting Voltage Response (TVR)
pext_Zeval	pext(0,0,Zeval[l/m])	Exterior field pressure at Zeval
lfront	0.5*pext_Zeval*conj(pext_Zeval)[Pa^2]/(rho0*c0)	On-axis intensity at Zeval
Ptot	intop1(down(acpr.lx)*acpr.nx+down(acpr.ly)*acpr.ny+down(acpr.lz)*acpr.nz)	Total radiated power
lave	Ptot/(4*pi*Zeval^2)	Average intensity of monopole source at Zeval
Di	lfront/lave	Intensity directivity
DI	10*log10(Di)	Directivity index of the tonpilz transducer
k0	2*pi*freq/c0	Wave number

TABLE 2: LIST OF VARIABLES.

NAME	EXPRESSION	DESCRIPTION
DI_fl_pist	$10 \cdot \log_{10} \left( \frac{(k_0 \cdot a)^2}{(1 - 2 \cdot \text{besselj}(1, 2 \cdot k_0 \cdot a) / (2 \cdot k_0 \cdot a))} \right)$	Directivity index of flanged piston
SPL_Zeval	intop3(subst(acpr.ffcl.Lp_pext,x,0,y,0,z,Zeval))	SPL at Zeval
SPL_rel	acpr.ffcl.Lp_pext-SPL_Zeval	SPL relative to 0 dB at Zeval

## Results and Discussion

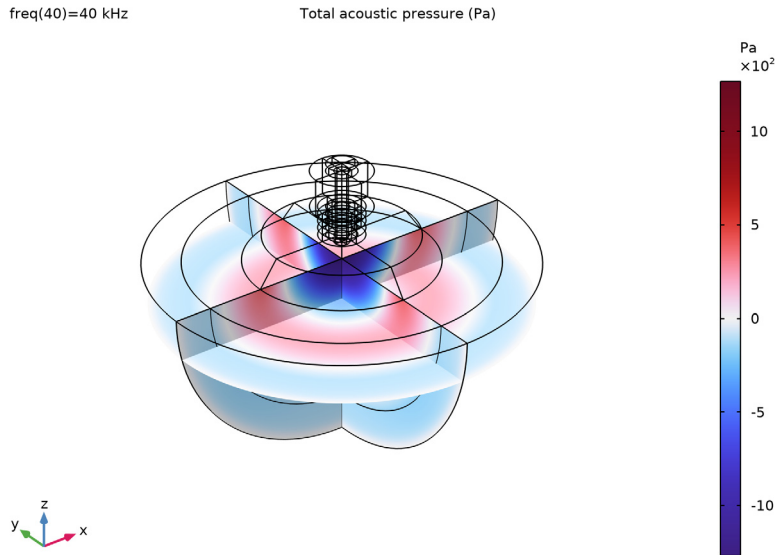
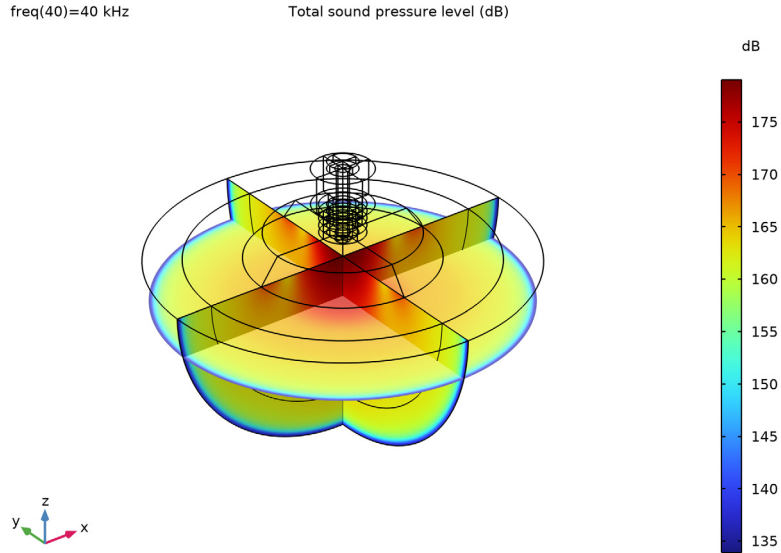

Figure 5: A multislice plot showing the total acoustic pressure variation in the water domain and PML at 40 kHz.

Figure 5 shows the total acoustic pressure in the water domain for 40 kHz excitation. The inner water domain in the model captures roughly half a wavelength at this frequency. As expected, the outer surface of the PML layer shows zero pressure which confirms that the PML layer effectively absorbs the outgoing waves. Setting the PML stretching type to rational allows us to effectively use the PML over a large range of wavelengths and angles of incidence of the pressure waves as encountered in this model.



*Figure 6: A multislice plot showing the sound pressure level (SPL) in the water domain and PML at 40 kHz.*

Figure 6 shows the sound pressure level (SPL) in the water domain for 40 kHz excitation. Note the 45 dB difference between the SPL near the transducer head mass and the outer surface of the PML layer. This once again confirms the effectiveness of the damping induced by the PML.

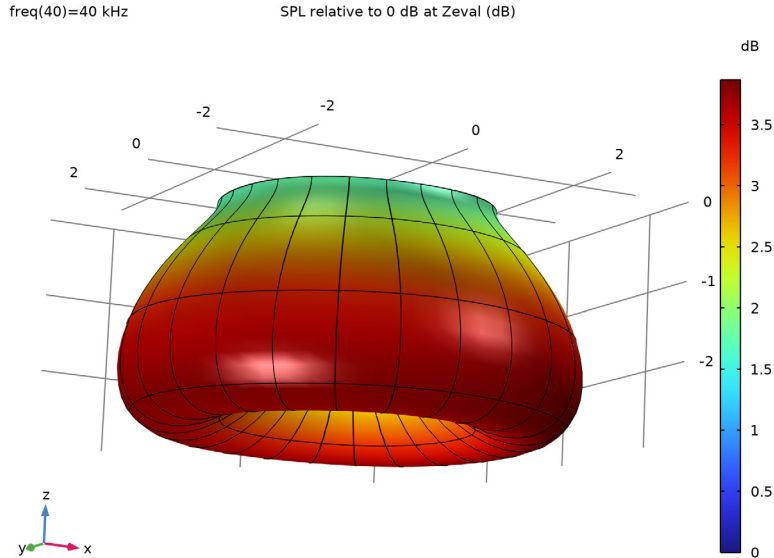

*Figure 7: A 3D radiation pattern plot showing the sound pressure level (SPL) for 40 kHz excitation at a distance of 10 m from the head mass. The SPL is computed relative to 0 dB at an on-axis distance of 10 m from the head mass.*

Figure 7 shows a 3D radiation pattern plot of the exterior field SPL computed at a radial distance of 10 m from the transducer head mass for 40 kHz excitation. The SPL shown here is computed relative to a value of 0 dB at an on-axis distance of 10 m directly ahead of the transducer head mass. This baseline value is computed by the user-defined variable `SPL_Zeva1` and the SPL relative to this quantity is computed by the variable `SPL_re1`. Note that you can control the baseline value by changing the value of the parameter `Zeva1`. You could also create similar plot for any of the other frequencies solved for and also at other distances outside the computational domain. The later can be controlled by manually specifying the radius of the sphere as the absolute value of the parameter `Zeva1` in the Evaluation section of the Radiation Pattern plot settings.

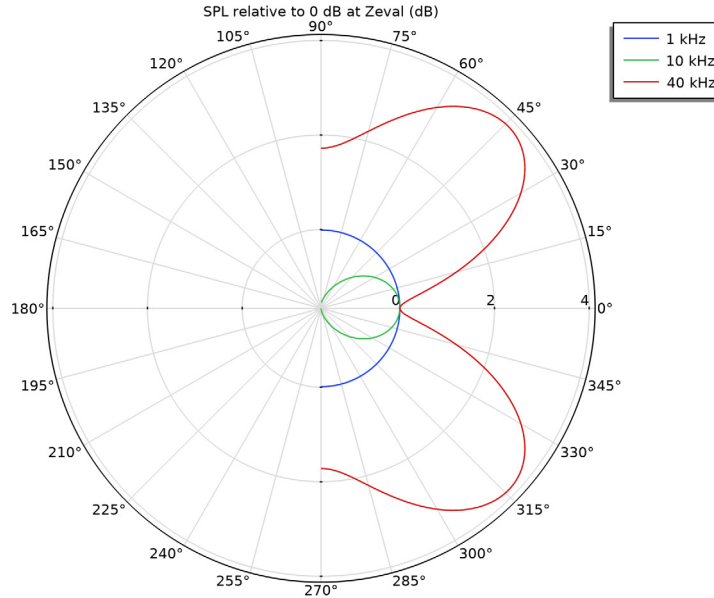

*Figure 8: A polar beam sensitivity plot showing the sound pressure level (SPL) for 1, 10, and 40 kHz excitation at a distance of 10 m from the head mass. The SPL is computed relative to 0 dB at an on-axis distance of 10 m from the head mass.*

Figure 8 shows a polar beam sensitivity plot which is also known as the beam pattern. Here the relative exterior field SPL is computed at a radial distance of 10 m from the transducer head mass for 1, 10, and 40 kHz excitation. The polar plot here shows the radiation pattern in the  $XZ$ -plane. The right half of the circle from  $270^\circ$  through  $0^\circ$  up to  $90^\circ$  correspond to the  $-Z$  hemisphere. The  $+Y$  direction is directed into the plane. The beam pattern shows that at a relatively lower frequency of 1 kHz, the sound emitted is fairly omnidirectional. This is because at low frequencies the transducer works in the piston mode.

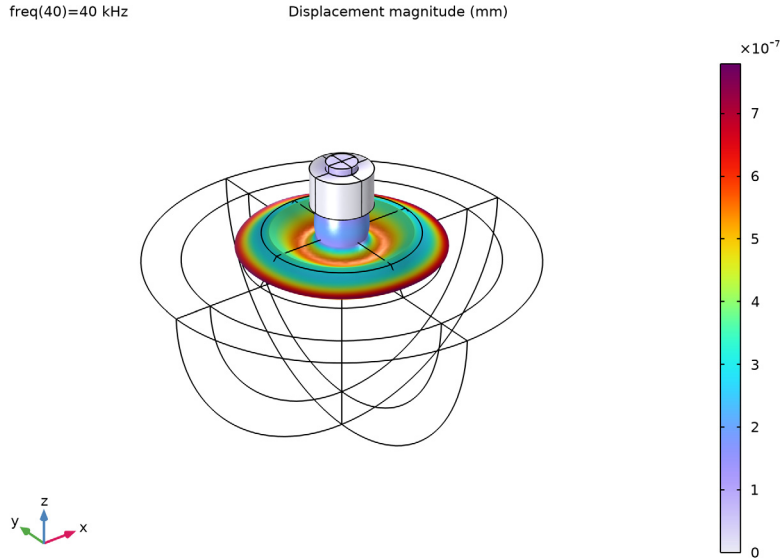

*Figure 9: Total structural displacement of the transducer at 40 kHz. An exaggerated deformation has been used for better visualization.*

Figure 9 shows the total structural displacement of the tonpilz transducer at 40 kHz excitation. At this frequency, the head mass vibrates in a mode whose shape is somewhat toroidal. This produces the lobes in the sound radiation pattern as can be seen in Figure 7 and Figure 8. If you observe the vibration mode for relatively lower frequencies, say 1 kHz, observe that the head mass vibrates mainly along its axis similar to a flanged piston.

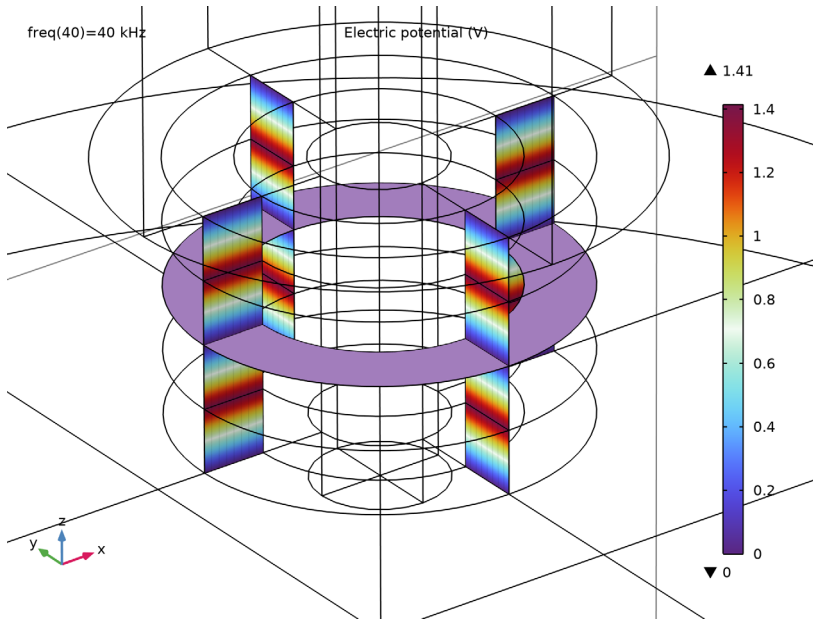

*Figure 10: A multislice plot of the electric potential distribution within the four PZT-4 disks.*

Figure 10 zooms on the piezo stacks. It shows the electric potential distribution through the thickness of the PZT-4 disks. The color bands indicate a successful implementation of the idea described in Figure 3.

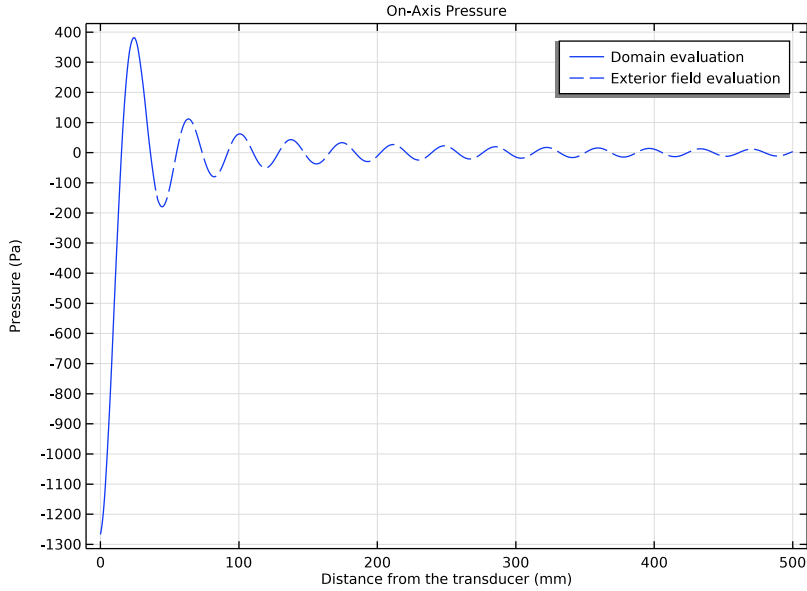

*Figure 11: A line plot of acoustic pressure variation directly ahead of the transducer head mass up to an on-axis distance of 500 mm.*

Figure 11 shows a plot of acoustic pressure versus  $z$ -coordinate along the axis of the transducer for an excitation frequency of 40 kHz. The blue curve shows the pressure variable  $p$  that is solved for versus the  $z$ -coordinate of the geometric edge that passes through the radius of the inner water domain vertically downward from the head mass along the transducer axis. The green curve shows how the pressure outside the computational domain can be computed using the exterior-field variable  $p_{\text{ext}}$  by using an expression  $p_{\text{ext}}(x, y, z)$ . The variable is evaluated using a parametric curve dataset to evaluate the variable outside the computational mesh.

This approach shows how to use a relatively small computational domain for efficient modeling and still use the results from the exterior field calculation in postprocessing to visualize both the magnitude and phase of the pressure outside the computational domain.

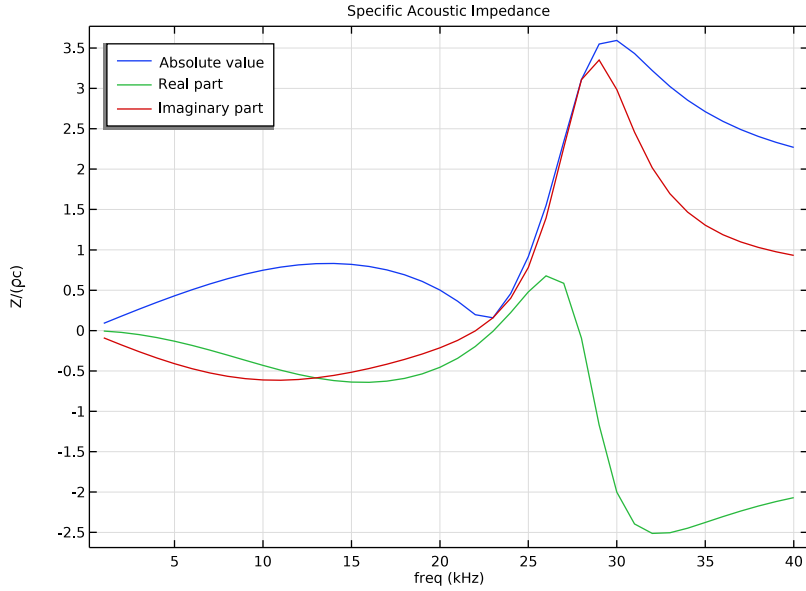

*Figure 12: Frequency response plot of the absolute value and the real and imaginary components of the specific acoustic impedance at the interface between the head mass and water.*

Figure 12 shows the frequency response of the specific acoustic impedance of the head mass surface that is exposed to water. A resonance and anti-resonance is observed within the frequency range of 20 kHz and 35 kHz.

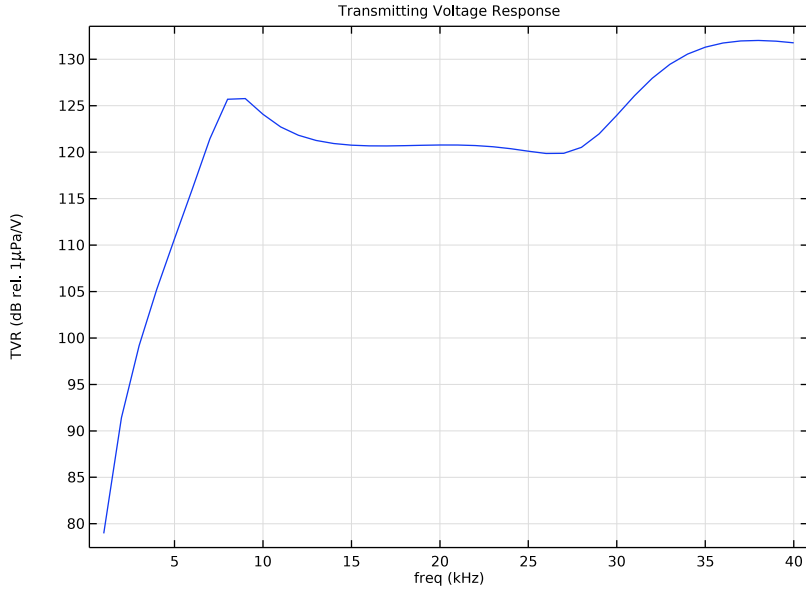

*Figure 13: Transmitting Voltage Response (TVR) as a function of frequency obtained at an on-axis distance of 1 m ahead of the head mass and computed relative to 1  $\mu$ Pa/V.*

Figure 13 shows the variation in the TVR of the transducer as a function of operating frequency. The fairly flat region between 15 kHz and 25 kHz can be particularly useful for sensing applications.

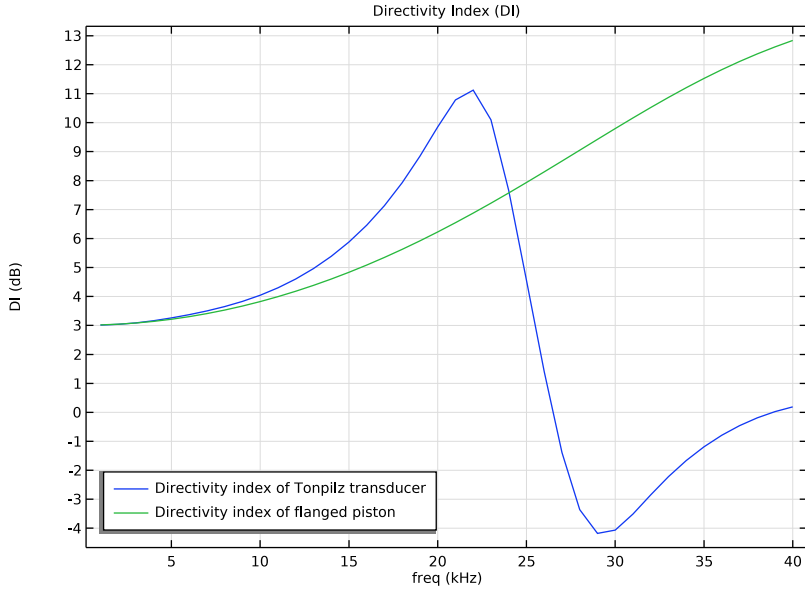

*Figure 14: Frequency response of the Directivity Index (DI) computed at an on-axis distance of 10 m from the head mass. The DI of the tonpilz transducer is compared to that of a flanged piston.*

Figure 14 shows the Directivity Index (DI) of the tonpilz transducer (blue curve) and compares it with the DI of a flanged piston (green curve). The latter can be computed from analytical expression as shown in Table 2. It is defined by the variable  $DI\_f1\_pist$ . Note that when the tonpilz transducer operates like a piston at lower frequencies, its DI becomes very similar to that of a flanged piston. Another feature worth noting is that within the range of 15 kHz and 25 kHz, the DI of the tonpilz transducer changes from nearly 0 dB to 11 dB while its TVR remains nearly constant. This can make the transducer quite versatile within this operating range.

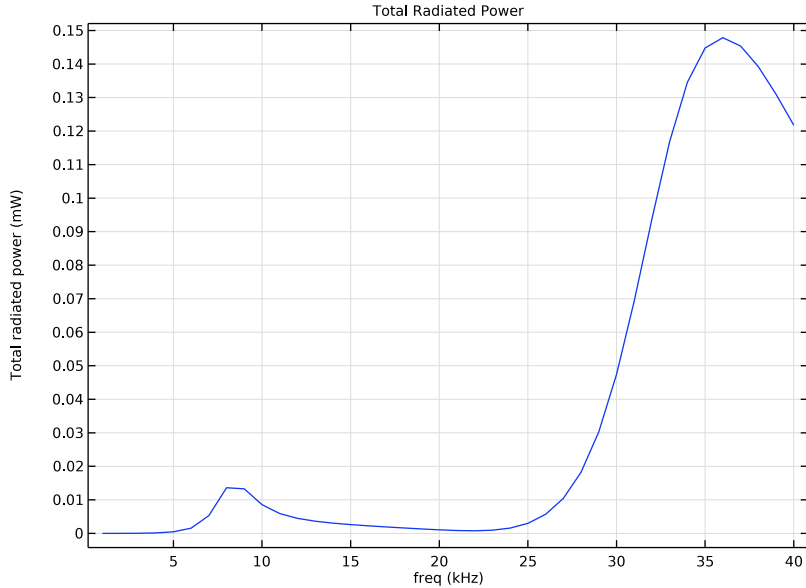

*Figure 15: Total radiated power from the tonpilz transducer within the operating frequency range of 1 kHz to 40 kHz.*

Figure 15 shows the total radiated power as a function of the operating frequency of the tonpilz transducer. Note that the acoustic radiated power should be always positive. In order to correctly compute the radiated power at the low frequency range you need to make some changes to the default settings of the Perfectly Matched Layer (PML).

The default settings produce negative radiated power at low frequencies. This happens because at low frequencies the evanescent waves extend into the PML layer. The interaction between the scaled coordinate system in the PML and these waves may create an erroneous energy contribution in the model (can be either positive or negative).

A good way to investigate the performance of the PML is to make a sensitivity analysis on some parameter (for example, the total radiated acoustic power) with respect to changes in the PML parameters. In this model, such a rigorous sensitivity analysis is not performed. In general, increasing the curvature factor effectively shifts the resolving power of the PML toward the physical domain, which is necessary in this case since the evanescent components decay in only a fraction of a wavelength. However, if you increase it too much, you may lose resolution in the other end, that is, of the free space wavelength. Assuming that the PMLs work properly at high frequencies for a curvature parameter of 1, you can

in principle perform a convergence study by increasing the value of the curvature parameter until the low-frequency (for 1 kHz) result converges while making sure that the high-frequency (for 40 kHz) result is not affected. It turns out that a value of 5 for the curvature parameter yields good results in this model. A scaling factor of 0.5 further improves the results, but only by a small amount. Decreasing the scaling factor corresponds to compressing the PML layer (shortening it), which in turn effectively increases the mesh resolution within the PML region.

Slice Plot of Exterior Pressure Field

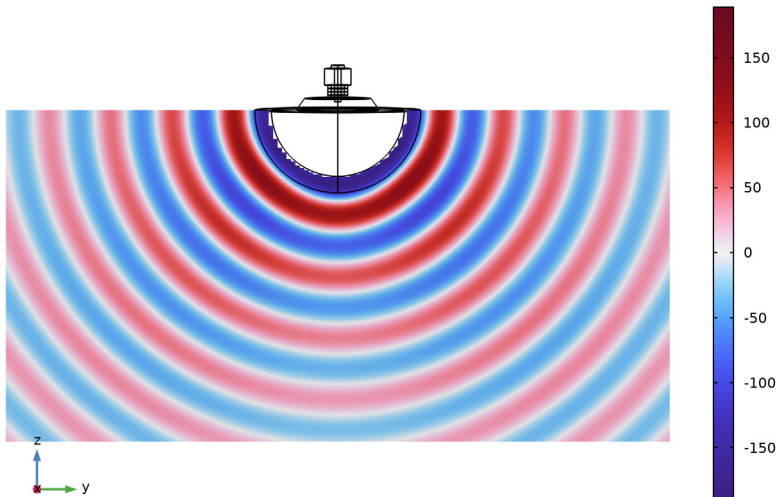

Figure 16: Pressure evaluated outside the computational mesh using the exterior field operator  $p_{ext}(x,y,z)$ .

As discussed above, the pressure (including phase) is evaluated outside the computational domain using the exterior field computation feature. The feature can evaluate the pressure (and phase) at any distance outside computational domain (as already seen in Figure 11) both in the near and in the far-field. The pressure outside the computational mesh is depicted in Figure 16 using the Grid 3D dataset. The sound pressure level is depicted in Figure 17.

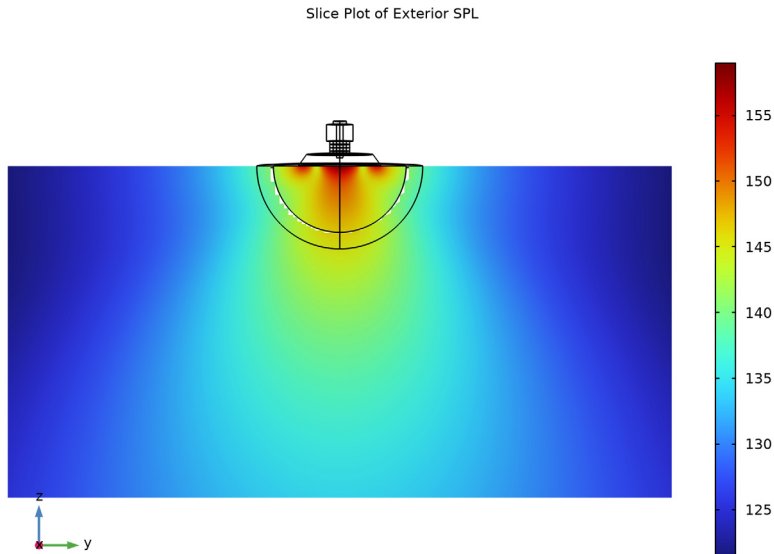

Figure 17: Sound pressure level evaluated outside the computational domain using the exterior field feature as well as the sound pressure level inside the domain.

### References

1. C.H. Sherman and J.L. Butler, *Transducers and Arrays for Underwater Sound*, Springer, New York, 2007.
2. M. Lasky, “Review of Undersea Acoustics to 1950,” *J. Acoust. Soc. Am.*, vol. 61, pp. 283–297, 1976.
3. D.T. Blackstock, *Fundamentals of Physical Acoustics*, John Wiley & Sons, 2000.

---

**Application Library path:** Acoustics\_Module/Piezoelectric\_Devices/  
tonpilz\_transducer

---



### Modeling Instructions

From the **File** menu, choose **New**.

## NEW

In the **New** window, click  **Model Wizard**.

## MODEL WIZARD

- 1 In the **Model Wizard** window, click  **3D**.
- 2 In the **Select Physics** tree, select **Acoustics** > **Acoustic–Structure Interaction** > **Acoustic–Piezoelectric Interaction, Frequency Domain**.
- 3 Click **Add**.
- 4 Click  **Study**.
- 5 In the **Select Study** tree, select **General Studies** > **Frequency Domain**.
- 6 Click  **Done**.

## GLOBAL DEFINITIONS



### *Parameters 1*

- 1 In the **Model Builder** window, under **Global Definitions** click **Parameters 1**.
- 2 In the **Settings** window for **Parameters**, locate the **Parameters** section.
- 3 Click  **Load from File**.
- 4 Browse to the model's Application Libraries folder and double-click the file `tonpilz_transducer_parameters.txt`.

## GEOMETRY 1

- 1 In the **Model Builder** window, under **Component 1 (comp1)** click **Geometry 1**.
- 2 In the **Settings** window for **Geometry**, locate the **Units** section.
- 3 From the **Length unit** list, choose **mm**.  
Build a plane section of the geometry before revolving it.

### *Work Plane 1 (wp1)*

- 1 In the **Geometry** toolbar, click  **Work Plane**.
- 2 In the **Settings** window for **Work Plane**, locate the **Plane Definition** section.
- 3 From the **Plane** list, choose **xz-plane**.  
Start with the solid domain.
- 4 Click  **Go to Plane Geometry**.

### *Work Plane 1 (wp1) > Rectangle 1 (r1)*

- 1 In the **Work Plane** toolbar, click  **Rectangle**.

- 2 In the **Settings** window for **Rectangle**, locate the **Size and Shape** section.
- 3 In the **Width** text field, type 4.
- 4 In the **Height** text field, type 2.
- 5 Locate the **Position** section. In the **yw** text field, type 25.

*Work Plane 1 (wp1) > Rectangle 2 (r2)*

- 1 In the **Work Plane** toolbar, click  **Rectangle**.
- 2 In the **Settings** window for **Rectangle**, locate the **Size and Shape** section.
- 3 In the **Width** text field, type 2.
- 4 In the **Height** text field, type 20.
- 5 Locate the **Position** section. In the **yw** text field, type 5.

*Work Plane 1 (wp1) > Rectangle 3 (r3)*

- 1 In the **Work Plane** toolbar, click  **Rectangle**.
- 2 In the **Settings** window for **Rectangle**, locate the **Size and Shape** section.
- 3 In the **Width** text field, type 6.
- 4 In the **Height** text field, type 10.
- 5 Locate the **Position** section. In the **xw** text field, type 2.
- 6 In the **yw** text field, type 15.

*Work Plane 1 (wp1) > Rectangle 4 (r4)*

- 1 In the **Work Plane** toolbar, click  **Rectangle**.
- 2 In the **Settings** window for **Rectangle**, locate the **Size and Shape** section.
- 3 In the **Width** text field, type 2.
- 4 In the **Height** text field, type 8.
- 5 Locate the **Position** section. In the **xw** text field, type 4.
- 6 In the **yw** text field, type 7.
- 7 Click to expand the **Layers** section. In the table, enter the following settings:

Layer name	Thickness (mm)
Layer 1	2
Layer 2	2
Layer 3	2

*Work Plane 1 (wp1) > Polygon 1 (pol1)*

- 1 In the **Work Plane** toolbar, click  **Polygon**.

- 2 In the **Settings** window for **Polygon**, locate the **Coordinates** section.
- 3 In the table, enter the following settings:



xw (mm)	yw (mm)
0	0
0	5
2	5
2	7
20	7
a	0

Then build the water domain.

*Work Plane 1 (wp1) > Circle 1 (c1)*

- 1 In the **Work Plane** toolbar, click  **Circle**.
- 2 In the **Settings** window for **Circle**, locate the **Size and Shape** section.
- 3 In the **Radius** text field, type  $R_{water} + R_{pm1}$ .
- 4 In the **Sector angle** text field, type 90.
- 5 Locate the **Rotation Angle** section. In the **Rotation** text field, type -90.
- 6 Click to expand the **Layers** section. In the table, enter the following settings:

Layer name	Thickness (mm)
Layer 1	$R_{pm1}$



- 7 In the **Work Plane** toolbar, click  **Build All**.
- 8 Click the  **Zoom Extents** button in the **Graphics** toolbar.

*Revolve 1 (rev1)*

- 1 In the **Model Builder** window, right-click **Geometry 1** and choose **Revolve**.
- 2 In the **Settings** window for **Revolve**, locate the **Revolution Angles** section.
- 3 Click the **Angles** button.
- 4 In the **End angle** text field, type 90.
- 5 Click  **Build Selected**.

*Rotate 1 (rot1)*

- 1 In the **Geometry** toolbar, click  **Transforms** and choose **Rotate**.
- 2 Select the object **rev1** only.
- 3 In the **Settings** window for **Rotate**, locate the **Rotation** section.

- 4 In the **Angle** text field, type range (90,90,270).
- 5 Locate the **Input** section. Select the **Keep input objects** checkbox.
- 6 Click  **Build All Objects**.
- 7 Click the  **Zoom Extents** button in the **Graphics** toolbar.

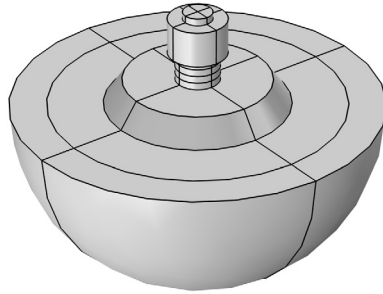

- 8 Click the  **Wireframe Rendering** button in the **Graphics** toolbar.

#### **DEFINITIONS**

Create domain selections that will be used in the modeling.

*Water domain - Inner*

- 1 In the **Definitions** toolbar, click  **Explicit**.
- 2 In the **Settings** window for **Explicit**, type *Water domain - Inner* in the **Label** text field.

3 Select Domains 3, 4, 22, and 32 only.

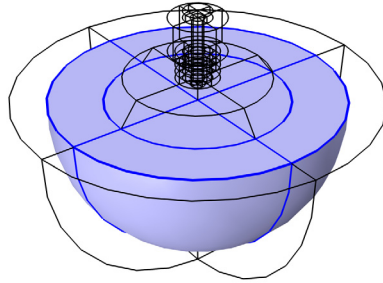

*Water domain - PML*

- 1 In the **Definitions** toolbar, click  **Explicit**.
- 2 In the **Settings** window for **Explicit**, type **Water domain - PML** in the **Label** text field.
- 3 Select Domains 1, 2, 21, and 31 only.

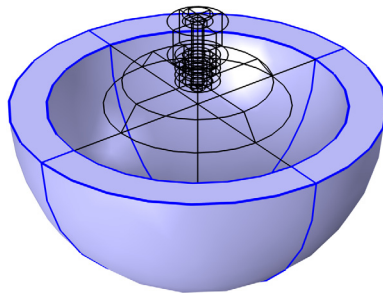

### Aluminum

- 1 In the **Definitions** toolbar, click  **Explicit**.
- 2 In the **Settings** window for **Explicit**, type Aluminum in the **Label** text field.
- 3 Select Domains 5, 6, 23, and 33 only.

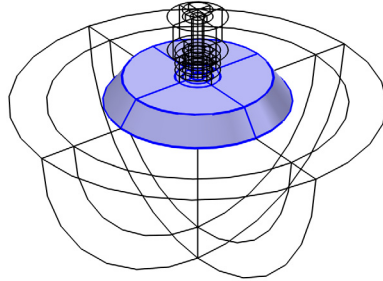

### Steel

- 1 In the **Definitions** toolbar, click  **Explicit**.
- 2 In the **Settings** window for **Explicit**, type Steel in the **Label** text field.

3 Select Domains 7, 8, 17–20, 24, 29, 30, and 34–36 only.

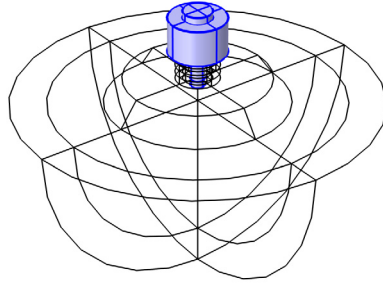

+Z *poled Piezo*

- 1 In the **Definitions** toolbar, click  **Explicit**.
- 2 In the **Settings** window for **Explicit**, type +Z poled Piezo in the **Label** text field.
- 3 Select Domains 9, 10, 13, 14, 25, 27, 37, and 39 only.

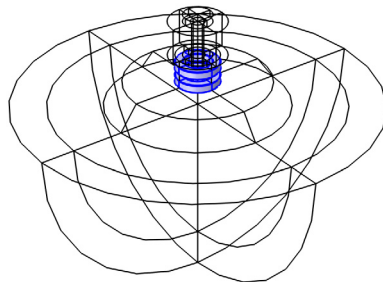



### *-Z poled Piezo*

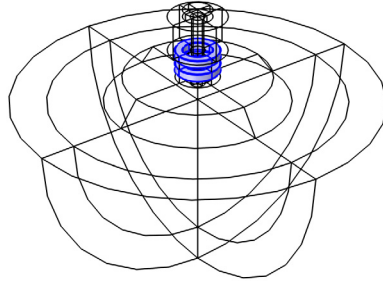

- 1 In the **Definitions** toolbar, click  **Explicit**.
- 2 In the **Settings** window for **Explicit**, type -Z poled Piezo in the **Label** text field.
- 3 Select Domains 11, 12, 15, 16, 26, 28, 38, and 40 only.



### *Water domains*

- 1 In the **Definitions** toolbar, click  **Union**.
- 2 In the **Settings** window for **Union**, type Water domains in the **Label** text field.
- 3 Locate the **Input Entities** section. Under **Selections to add**, click  **Add**.
- 4 In the **Add** dialog, in the **Selections to add** list, choose **Water domain - Inner** and **Water domain - PML**.
- 5 Click **OK**.

### *Piezo domains*

- 1 In the **Definitions** toolbar, click  **Union**.
- 2 In the **Settings** window for **Union**, type Piezo domains in the **Label** text field.
- 3 Locate the **Input Entities** section. Under **Selections to add**, click  **Add**.
- 4 In the **Add** dialog, in the **Selections to add** list, choose **+Z poled Piezo** and **-Z poled Piezo**.
- 5 Click **OK**.

### *Solid domains*

- 1 In the **Definitions** toolbar, click  **Complement**.
- 2 In the **Settings** window for **Complement**, type Solid domains in the **Label** text field.
- 3 Locate the **Input Entities** section. Under **Selections to invert**, click **+ Add**.
- 4 In the **Add** dialog, select **Water domains** in the **Selections to invert** list.
- 5 Click **OK**.

### *Non-PML domains*

- 1 In the **Definitions** toolbar, click  **Complement**.
- 2 In the **Settings** window for **Complement**, type Non-PML domains in the **Label** text field.
- 3 Locate the **Input Entities** section. Under **Selections to invert**, click **+ Add**.
- 4 In the **Add** dialog, select **Water domain - PML** in the **Selections to invert** list.
- 5 Click **OK**.

Create boundary selections that will be used in the modeling.

### *Ground boundaries*

- 1 In the **Definitions** toolbar, click  **Explicit**.
- 2 In the **Settings** window for **Explicit**, type Ground boundaries in the **Label** text field.
- 3 Locate the **Input Entities** section. From the **Geometric entity level** list, choose **Boundary**.
- 4 Select Boundaries 28, 29, 38, 39, 45, 46, 93, 99, 103, 145, 151, and 155 only.

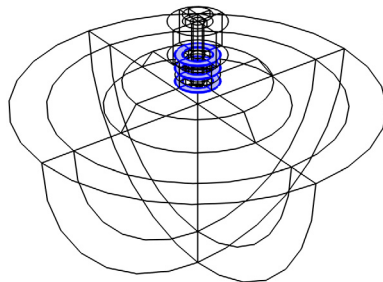

### *Voltage boundaries*

- 1 In the **Definitions** toolbar, click  **Explicit**.
- 2 In the **Settings** window for **Explicit**, type Voltage boundaries in the **Label** text field.
- 3 Locate the **Input Entities** section. From the **Geometric entity level** list, choose **Boundary**.
- 4 Select Boundaries 33, 34, 43, 44, 96, 102, 148, and 154 only.

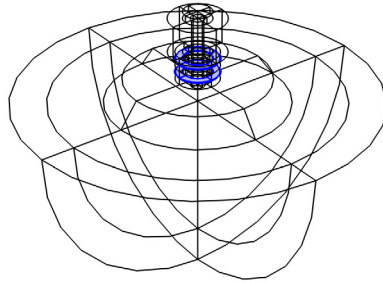

### *Fixed boundaries*

- 1 In the **Definitions** toolbar, click  **Explicit**.
- 2 In the **Settings** window for **Explicit**, type Fixed boundaries in the **Label** text field.
- 3 Locate the **Input Entities** section. From the **Geometric entity level** list, choose **Boundary**.

4 Select Boundaries 19, 20, 88, and 164 only.

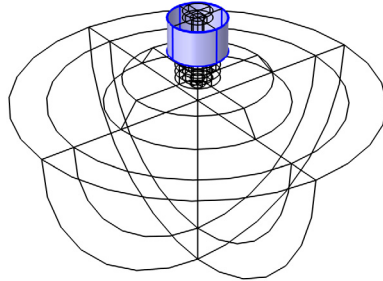

#### *Exterior Field boundaries*

- 1 In the **Definitions** toolbar, click  **Explicit**.
- 2 In the **Settings** window for **Explicit**, type Exterior Field boundaries in the **Label** text field.
- 3 Locate the **Input Entities** section. From the **Geometric entity level** list, choose **Boundary**.

- 4 Select Boundaries 9, 10, 82, and 125 only.

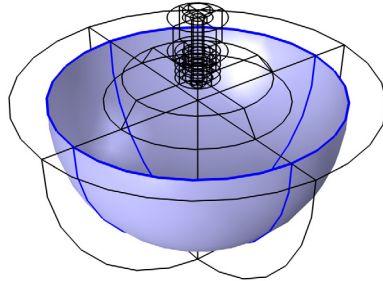

Define a nonlocal integration coupling on the exterior-field boundary.

*Integration 1 (intop1)*

- 1 In the **Definitions** toolbar, click  **Nonlocal Couplings** and choose **Integration**.
- 2 In the **Settings** window for **Integration**, locate the **Source Selection** section.
- 3 From the **Geometric entity level** list, choose **Boundary**.
- 4 From the **Selection** list, choose **Exterior Field boundaries**.

Define a nonlocal integration coupling on the acoustic-structure interface.

*Integration 2 (intop2)*

- 1 In the **Definitions** toolbar, click  **Nonlocal Couplings** and choose **Integration**.
- 2 In the **Settings** window for **Integration**, locate the **Source Selection** section.
- 3 From the **Geometric entity level** list, choose **Boundary**.

4 Select Boundaries 14, 15, 85, and 128 only.

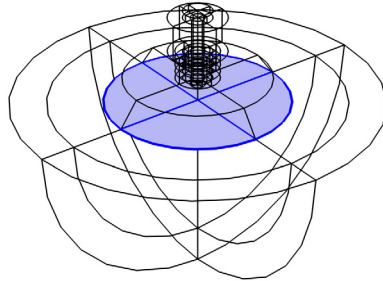

Define a nonlocal integration coupling to retrieve values at the summit point of the water domain.

*Integration 3 (intop3)*

- 1 In the **Definitions** toolbar, click  **Nonlocal Couplings** and choose **Integration**.
- 2 In the **Settings** window for **Integration**, locate the **Source Selection** section.
- 3 From the **Geometric entity level** list, choose **Point**.

4 Select Point 46 only.

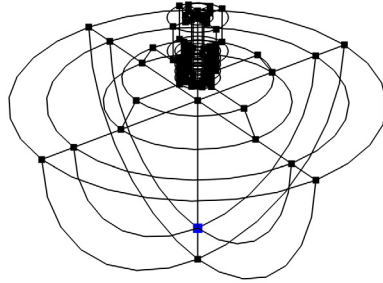

Define a rotated system that will be used for the poling of the -Z poled piezoelectric disks.

#### *Rotated System 2 (sys2)*

- 1 In the **Definitions** toolbar, click  **Coordinate Systems** and choose **Rotated System**.
- 2 In the **Settings** window for **Rotated System**, locate the **Rotation** section.
- 3 Find the **Euler angles** subsection. In the  $\beta$  text field, type  $\pi$ .

Insert a Perfectly Matched Layer to model the absorption of acoustic waves far away from the source.



#### *Perfectly Matched Layer 1 (pml1)*

- 1 In the **Definitions** toolbar, click  **Perfectly Matched Layer**.
- 2 In the **Settings** window for **Perfectly Matched Layer**, locate the **Domain Selection** section.
- 3 From the **Selection** list, choose **Water domain - PML**.
- 4 Locate the **Geometry** section. From the **Type** list, choose **Spherical**.
- 5 Locate the **Scaling** section. From the **Coordinate stretching type** list, choose **Rational**.
- 6 In the **PML scaling factor** text field, type 0.5.
- 7 In the **PML scaling curvature parameter** text field, type 5.

## MATERIALS

Add water, aluminum, steel, and piezoelectric materials from the Material Library.

### ADD MATERIAL

- 1 In the **Materials** toolbar, click  **Add Material** to open the **Add Material** window.
- 2 Go to the **Add Material** window.
- 3 In the tree, select **Built-in > Water, liquid**.
- 4 Click the **Add to Component** button in the window toolbar.
- 5 In the tree, select **Built-in > Aluminum**.
- 6 Click the **Add to Component** button in the window toolbar.
- 7 In the tree, select **Built-in > Steel AISI 4340**.
- 8 Click the **Add to Component** button in the window toolbar.
- 9 In the tree, select **Piezoelectric > Lead Zirconate Titanate (PZT-4)**.
- 10 Click the **Add to Component** button in the window toolbar.
- 11 In the **Materials** toolbar, click  **Add Material** to close the **Add Material** window.

## MATERIALS

*Water, liquid (mat1)*

- 1 In the **Settings** window for **Material**, locate the **Geometric Entity Selection** section.
- 2 From the **Selection** list, choose **Water domains**.

*Aluminum (mat2)*

- 1 In the **Model Builder** window, click **Aluminum (mat2)**.
- 2 In the **Settings** window for **Material**, locate the **Geometric Entity Selection** section.
- 3 From the **Selection** list, choose **Aluminum**.

*Steel AISI 4340 (mat3)*

- 1 In the **Model Builder** window, click **Steel AISI 4340 (mat3)**.
- 2 In the **Settings** window for **Material**, locate the **Geometric Entity Selection** section.
- 3 From the **Selection** list, choose **Steel**.

*Lead Zirconate Titanate (PZT-4) (mat4)*

- 1 In the **Model Builder** window, click **Lead Zirconate Titanate (PZT-4) (mat4)**.
- 2 In the **Settings** window for **Material**, locate the **Geometric Entity Selection** section.
- 3 From the **Selection** list, choose **Piezo domains**.

## **PRESSURE ACOUSTICS, FREQUENCY DOMAIN (ACPR)**

Define physics settings and boundary conditions.

- 1 In the **Model Builder** window, under **Component 1 (comp1)** click **Pressure Acoustics, Frequency Domain (acpr)**.
- 2 In the **Settings** window for **Pressure Acoustics, Frequency Domain**, locate the **Domain Selection** section.
- 3 From the **Selection** list, choose **Water domains**.
- 4 Locate the **Sound Pressure Level Settings** section. From the **Reference pressure for the sound pressure level** list, choose **Use reference pressure for water**.

### *Exterior Field Calculation 1*

- 1 In the **Physics** toolbar, click  **Boundaries** and choose **Exterior Field Calculation**.
- 2 In the **Settings** window for **Exterior Field Calculation**, locate the **Boundary Selection** section.
- 3 From the **Selection** list, choose **Exterior Field boundaries**.
- 4 Locate the **Exterior Field Calculation** section. From the **Condition in the  $z = z_0$  plane** list, choose **Symmetric/Infinite sound hard boundary**.

## **SOLID MECHANICS (SOLID)**

- 1 In the **Model Builder** window, under **Component 1 (comp1)** click **Solid Mechanics (solid)**.
- 2 In the **Settings** window for **Solid Mechanics**, locate the **Domain Selection** section.
- 3 From the **Selection** list, choose **Solid domains**.

### *Piezoelectric Material 1*

- 1 In the **Model Builder** window, under **Component 1 (comp1) > Solid Mechanics (solid)** click **Piezoelectric Material 1**.
- 2 In the **Settings** window for **Piezoelectric Material**, locate the **Domain Selection** section.
- 3 From the **Selection** list, choose **+Z poled Piezo**.

### *Piezoelectric Material 2*

- 1 In the **Physics** toolbar, click  **Domains** and choose **Piezoelectric Material**.
- 2 In the **Settings** window for **Piezoelectric Material**, locate the **Domain Selection** section.
- 3 From the **Selection** list, choose **-Z poled Piezo**.
- 4 Locate the **Coordinate System Selection** section. From the **Coordinate system** list, choose **Rotated System 2 (sys2)**.

### *Fixed Constraint I*

- 1 In the **Physics** toolbar, click  **Boundaries** and choose **Fixed Constraint**.
- 2 In the **Settings** window for **Fixed Constraint**, locate the **Boundary Selection** section.
- 3 From the **Selection** list, choose **Fixed boundaries**.

### **ELECTROSTATICS (ES)**

- 1 In the **Model Builder** window, under **Component 1 (comp1)** click **Electrostatics (es)**.
- 2 In the **Settings** window for **Electrostatics**, locate the **Domain Selection** section.
- 3 From the **Selection** list, choose **Piezo domains**.

### *Ground I*

- 1 In the **Physics** toolbar, click  **Boundaries** and choose **Ground**.
- 2 In the **Settings** window for **Ground**, locate the **Boundary Selection** section.
- 3 From the **Selection** list, choose **Ground boundaries**.

### *Electric Potential I*

- 1 In the **Physics** toolbar, click  **Boundaries** and choose **Electric Potential**.
- 2 In the **Settings** window for **Electric Potential**, locate the **Boundary Selection** section.
- 3 From the **Selection** list, choose **Voltage boundaries**.
- 4 Locate the **Electric Potential** section. In the  $V_0$  text field, type  $V_0$ .

Mesh the geometry; create a tetrahedral mesh in the solid and the water-inner domains and create a swept mesh in the PML.

### **MESH I**

#### *Free Tetrahedral I*

- 1 In the **Mesh** toolbar, click  **Free Tetrahedral**.
- 2 In the **Settings** window for **Free Tetrahedral**, locate the **Domain Selection** section.
- 3 From the **Geometric entity level** list, choose **Domain**.
- 4 From the **Selection** list, choose **Non-PML domains**.

Define a mesh size in the water domain to ensure that the smallest wavelength is resolved by at least 5 elements (here, select  $\lambda_0/6$ ).

#### *Size I*

- 1 Right-click **Free Tetrahedral I** and choose **Size**.
- 2 In the **Settings** window for **Size**, locate the **Geometric Entity Selection** section.
- 3 From the **Selection** list, choose **Water domains**.

- 4 Locate the **Element Size** section. Click the **Custom** button.
- 5 Locate the **Element Size Parameters** section.
- 6 Select the **Maximum element size** checkbox. In the associated text field, type  $1500[m/s]/f_{0max}/6$ .

#### *Size 2*

- 1 In the **Model Builder** window, right-click **Free Tetrahedral 1** and choose **Size**.
- 2 In the **Settings** window for **Size**, locate the **Geometric Entity Selection** section.
- 3 From the **Selection** list, choose **Solid domains**.
- 4 Locate the **Element Size** section. Click the **Custom** button.
- 5 Locate the **Element Size Parameters** section.
- 6 Select the **Resolution of narrow regions** checkbox. In the associated text field, type 2.  
This setting ensures at least two mesh elements in the narrow layers of the piezo disks and bolt.

#### *Swept 1*

In the **Mesh** toolbar, click  **Swept**.

#### *Distribution 1*

- 1 Right-click **Swept 1** and choose **Distribution**.  
Create a boundary layer at the external boundaries of the water domain. This will ensure numerically well defined normal gradients used in the exterior-field calculation feature. Turn off the smoothing option.

#### *Boundary Layers 1*

- 1 In the **Mesh** toolbar, click  **Boundary Layers**.
- 2 In the **Settings** window for **Boundary Layers**, locate the **Geometric Entity Selection** section.
- 3 From the **Geometric entity level** list, choose **Domain**.
- 4 From the **Selection** list, choose **Water domain - Inner**.
- 5 Click to expand the **Transition** section. Clear the **Smooth transition to interior mesh** checkbox.

#### *Boundary Layer Properties*

- 1 In the **Model Builder** window, click **Boundary Layer Properties**.
- 2 In the **Settings** window for **Boundary Layer Properties**, locate the **Boundary Selection** section.

- 3 From the **Selection** list, choose **Exterior Field boundaries**.
- 4 Locate the **Layers** section. In the **Number of layers** text field, type 1.
- 5 From the **Thickness specification** list, choose **First layer**.
- 6 In the **Thickness** text field, type  $1500[\text{m/s}] / f_{0\text{max}} / 6 / 20$ .
- 7 In the **Model Builder** window, right-click **Mesh 1** and choose **Build All**.
- 8 Click the  **Go to Default View** button in the **Graphics** toolbar.

## DEFINITIONS

Import the file containing the variable definitions. These variables will mainly be used for postprocessing calculations.

### *Variables 1*

- 1 In the **Model Builder** window, under **Component 1 (comp1)** right-click **Definitions** and choose **Variables**.
- 2 In the **Settings** window for **Variables**, locate the **Variables** section.
- 3 Click  **Load from File**.
- 4 Browse to the model's Application Libraries folder and double-click the file `tonpilz_transducer_variables.txt`.

## STUDY 1

### *Step 1: Frequency Domain*

- 1 In the **Model Builder** window, under **Study 1** click **Step 1: Frequency Domain**.
- 2 In the **Settings** window for **Frequency Domain**, locate the **Study Settings** section.
- 3 From the **Frequency unit** list, choose **kHz**.
- 4 In the **Frequencies** text field, type `range(f0min, f0step, f0max)`.
- 5 In the **Study** toolbar, click  **Compute**.

## RESULTS

### *Acoustic Pressure (acpr)*



- 1 In the **Settings** window for **3D Plot Group**, locate the **Plot Settings** section.
- 2 From the **View** list, choose **View 1**.

Delete the default surface plot and replace it by a multislice plot, which shows the value of the acoustic pressure inside the water domain.

### Surface 1

- 1 In the **Model Builder** window, expand the **Acoustic Pressure (acpr)** node.
- 2 Right-click **Surface 1** and choose **Delete**.

### Multislice 1

- 1 In the **Acoustic Pressure (acpr)** toolbar, click  **More Plots** and choose **Multislice**.
- 2 Click  **Plot**.
- 3 Click the  **Zoom Extents** button in the **Graphics** toolbar.

This plot should look like [Figure 5](#).

### Sound Pressure Level (acpr)



- 1 In the **Model Builder** window, under **Results** click **Sound Pressure Level (acpr)**.
- 2 In the **Settings** window for **3D Plot Group**, locate the **Plot Settings** section.
- 3 From the **View** list, choose **View 1**.

Do the same as for the acoustic pressure plot.

### Surface 1

- 1 In the **Model Builder** window, expand the **Sound Pressure Level (acpr)** node.
- 2 Right-click **Surface 1** and choose **Delete**.

### Multislice 1

- 1 In the **Sound Pressure Level (acpr)** toolbar, click  **More Plots** and choose **Multislice**.
- 2 In the **Settings** window for **Multislice**, click **Replace Expression** in the upper-right corner of the **Expression** section. From the menu, choose **Component 1 (comp1) > Pressure Acoustics, Frequency Domain > Pressure and sound pressure level > acpr.Lp\_t - Total sound pressure level - dB**.
- 3 Locate the **Coloring and Style** section. From the **Color table** list, choose **Rainbow**.
- 4 From the **Scale** list, choose **Linear**.
- 5 In the **Sound Pressure Level (acpr)** toolbar, click  **Plot**.

This plot should look like [Figure 6](#).

### Exterior-Field Sound Pressure Level (acpr)

Plot the sound pressure level at 10 meters relative to the value on the **Z**-axis.

### Radiation Pattern 1

- 1 In the **Model Builder** window, expand the **Exterior-Field Sound Pressure Level (acpr)** node, then click **Radiation Pattern 1**.
- 2 In the **Settings** window for **Radiation Pattern**, locate the **Expression** section.

- 3 In the **Expression** text field, type `SPL_re1`.
- 4 Locate the **Evaluation** section. Find the **Angles** subsection. From the **Restriction** list, choose **Manual**.
- 5 In the  $\theta$  **start** text field, type 90.
- 6 In the  $\theta$  **range** text field, type 90.
- 7 Find the **Sphere** subsection. From the **Sphere** list, choose **Manual**.
- 8 In the **Radius** text field, type `abs(Zeval)`.
- 9 In the **Exterior-Field Sound Pressure Level (acpr)** toolbar, click  **Plot**.

Change the view in the graphics window to obtain a plot similar to [Figure 7](#).

Plot the Exterior-Field Sound Pressure Level in the  $XZ$ -plane for several frequencies.

#### *Relative Polar Beam Sensitivity*

- 1 In the **Model Builder** window, expand the **Exterior-Field Pressure (acpr)** node, then click **Results > Exterior-Field Sound Pressure Level xy-plane (acpr)**.
- 2 In the **Settings** window for **Polar Plot Group**, type *Relative Polar Beam Sensitivity* in the **Label** text field.
- 3 Locate the **Data** section. From the **Parameter selection (freq)** list, choose **From list**.
- 4 In the **Parameter values (freq (kHz))** list, choose **1**, **10**, and **40**.

#### *Radiation Pattern I*

- 1 In the **Model Builder** window, expand the **Relative Polar Beam Sensitivity** node, then click **Radiation Pattern I**.
- 2 In the **Settings** window for **Radiation Pattern**, locate the **Expression** section.
- 3 In the **Expression** text field, type `SPL_re1`.
- 4 Locate the **Evaluation** section. Find the **Angles** subsection. From the **Restriction** list, choose **Manual**.
- 5 In the  $\phi$  **start** text field, type -90.
- 6 In the  $\phi$  **range** text field, type 180.
- 7 Find the **Reference direction** subsection. In the **x** text field, type 0.
- 8 In the **z** text field, type -1.  
The reference direction defines that 0 deg. in the polar plot corresponds to the negative  $z$ -axis direction.
- 9 Find the **Normal vector** subsection. In the **y** text field, type 1.
- 10 In the **z** text field, type 0.

11 Find the **Evaluation distance** subsection. In the **Radius** text field, type `abs(Zeva1)`.

#### *Relative Polar Beam Sensitivity*

1 In the **Model Builder** window, click **Relative Polar Beam Sensitivity**.

2 In the **Relative Polar Beam Sensitivity** toolbar, click  **Plot**.

This plot should look like [Figure 8](#).

Replace the stress plot by displacement in solid.

#### *Displacement*

1 In the **Model Builder** window, under **Results** click **Stress (solid)**.

2 In the **Settings** window for **3D Plot Group**, type Displacement in the **Label** text field.

3 Locate the **Plot Settings** section. From the **View** list, choose **View 1**.

#### *Volume 1*

1 In the **Model Builder** window, expand the **Displacement** node, then click **Volume 1**.

2 In the **Settings** window for **Volume**, click **Replace Expression** in the upper-right corner of the **Expression** section. From the menu, choose **Component 1 (comp1) > Solid Mechanics > Displacement > solid.disp - Displacement magnitude - m**.

#### *Displacement*

1 In the **Model Builder** window, click **Displacement**.

2 In the **Displacement** toolbar, click  **Plot**.

This plot should look like [Figure 9](#).

#### *Electric Potential (es)*

1 In the **Model Builder** window, click **Electric Potential (es)**.

2 In the **Settings** window for **3D Plot Group**, locate the **Plot Settings** section.

3 From the **View** list, choose **New view**.

This gives a dedicated view for the electric potential in the piezoelectric disks.

4 In the **Electric Potential (es)** toolbar, click  **Plot**.

Use the **Zoom Box** in the **Graphics** window to obtain a plot similar to [Figure 10](#).

Insert a 1D plot group to obtain the on-axis pressure graph shown in [Figure 11](#).

First, create a parametric curve dataset to enable plotting of the exterior-field variable outside the computational mesh: from the edge of the exterior-field boundary to 500 mm in front of the transducer.

### *Parametric Curve 3D 1*

- 1 In the **Results** toolbar, click  **More Datasets** and choose **Parametric Curve 3D**.
- 2 In the **Settings** window for **Parametric Curve 3D**, locate the **Expressions** section.
- 3 In the **z** text field, type  $(1-s)*(-1.02*R_{water})-s*500[\text{mm}]$ .
- 4 Select the **Only evaluate globally defined expressions** checkbox.

### *On-Axis Pressure*

- 1 In the **Results** toolbar, click  **ID Plot Group**.
- 2 In the **Settings** window for **ID Plot Group**, type **On-Axis Pressure** in the **Label** text field.
- 3 Locate the **Data** section. From the **Parameter selection (freq)** list, choose **Last**.
- 4 Click to expand the **Title** section. From the **Title type** list, choose **Label**.
- 5 Locate the **Plot Settings** section.
- 6 Select the **x-axis label** checkbox. In the associated text field, type **Distance from the transducer (mm)**.
- 7 Select the **y-axis label** checkbox. In the associated text field, type **Pressure (Pa)**.

### *Line Graph 1*

- 1 Right-click **On-Axis Pressure** and choose **Line Graph**.
- 2 Select Edge 136 only.
- 3 In the **Settings** window for **Line Graph**, click **Replace Expression** in the upper-right corner of the **y-Axis Data** section. From the menu, choose **Component 1 (comp1) > Pressure Acoustics, Frequency Domain > Pressure and sound pressure level > p - Acoustic pressure - Pa**.
- 4 Locate the **x-Axis Data** section. From the **Parameter** list, choose **Expression**.
- 5 In the **Expression** text field, type **-z**.
- 6 Click to expand the **Legends** section. Select the **Show legends** checkbox.
- 7 From the **Legends** list, choose **Manual**.
- 8 In the table, enter the following settings:

---

#### **Legends**

---

Domain evaluation

---

### *Line Graph 2*

- 1 In the **Model Builder** window, right-click **On-Axis Pressure** and choose **Line Graph**.
- 2 In the **Settings** window for **Line Graph**, locate the **Data** section.

- 3 From the **Dataset** list, choose **Parametric Curve 3D I**.
- 4 From the **Parameter selection (freq)** list, choose **Last**.
- 5 Locate the **y-Axis Data** section. In the **Expression** text field, type  $\text{pext}(x, y, z)$ .
- 6 Locate the **x-Axis Data** section. From the **Parameter** list, choose **Expression**.
- 7 In the **Expression** text field, type  $-z$ .
- 8 Click to expand the **Coloring and Style** section. From the **Color** list, choose **Cycle (reset)**.
- 9 Find the **Line style** subsection. From the **Line** list, choose **Dashed**.
- 10 Locate the **Legends** section. Select the **Show legends** checkbox.
- 11 From the **Legends** list, choose **Manual**.
- 12 In the table, enter the following settings:

Legends
Exterior field evaluation

- 13 In the **On-Axis Pressure** toolbar, click  **Plot**.

Insert a 1D plot to obtain the calculated specific acoustic impedance shown in [Figure 12](#).

#### *Specific Acoustic Impedance*

- 1 In the **Results** toolbar, click  **ID Plot Group**.
- 2 In the **Settings** window for **ID Plot Group**, type Specific Acoustic Impedance in the **Label** text field.
- 3 Locate the **Title** section. From the **Title type** list, choose **Label**.
- 4 Locate the **Plot Settings** section.
- 5 Select the **y-axis label** checkbox. In the associated text field, type  $Z/(\rho c)$ .
- 6 Locate the **Legend** section. From the **Position** list, choose **Upper left**.

#### *Global I*

- 1 Right-click **Specific Acoustic Impedance** and choose **Global**.
- 2 In the **Settings** window for **Global**, locate the **y-Axis Data** section.
- 3 In the table, enter the following settings:

Expression	Unit	Description
$\text{abs}(Zaco)$	1	
$\text{real}(Zaco)$	1	
$\text{imag}(Zaco)$	1	

- 4 Click to expand the **Legends** section. From the **Legends** list, choose **Manual**.
- 5 In the table, enter the following settings:

<b>Legends</b>
Absolute value
Real part
Imaginary part

- 6 In the **Specific Acoustic Impedance** toolbar, click  **Plot**.

#### *Specific Acoustic Impedance*

Duplicate the last plot group and replace it by the transmitting voltage response to obtain the graph shown in [Figure 13](#).

#### *Transmitting Voltage Response*

- 1 In the **Model Builder** window, right-click **Specific Acoustic Impedance** and choose **Duplicate**.
- 2 In the **Settings** window for **ID Plot Group**, type Transmitting Voltage Response in the **Label** text field.
- 3 Locate the **Plot Settings** section. In the **y-axis label** text field, type TVR (dB re1. 1\mu Pa/V).
- 4 Locate the **Legend** section. From the **Position** list, choose **Lower right**.

#### *Global 1*

- 1 In the **Model Builder** window, expand the **Transmitting Voltage Response** node, then click **Global 1**.
- 2 In the **Settings** window for **Global**, locate the **y-Axis Data** section.
- 3 Ctrl-click to select table rows 2 and 3.
- 4 Click  **Delete**.
- 5 In the table, enter the following settings:

<b>Expression</b>	<b>Unit</b>	<b>Description</b>
TVR		Transmitting Voltage Response (TVR)

- 6 Locate the **Legends** section. Clear the **Show legends** checkbox.

7 In the **Transmitting Voltage Response** toolbar, click  **Plot**.

An alternative approach to create the above plot is to use the Octave Band Plot. Set the geometric-entity level to global, set the expression to  $\text{pext}(0,0,-1)$ , reference to  $1[\text{uPa}/\text{V}]/V_{\text{rms}}$ , and the style to continuous.

#### *Specific Acoustic Impedance*

Duplicate the previous plot group and modify it to plot the directivity index like in [Figure 14](#).



#### *Directivity Index (DI)*

- 1 In the **Model Builder** window, right-click **Specific Acoustic Impedance** and choose **Duplicate**.
- 2 In the **Settings** window for **ID Plot Group**, type **Directivity Index (DI)** in the **Label** text field.
- 3 Locate the **Plot Settings** section. In the **y-axis label** text field, type **DI (dB)**.
- 4 Locate the **Legend** section. From the **Position** list, choose **Lower left**.

#### *Global I*

- 1 In the **Model Builder** window, expand the **Directivity Index (DI)** node, then click **Global I**.
- 2 In the **Settings** window for **Global**, locate the **y-Axis Data** section.
- 3 In the table, enter the following settings:

Expression	Unit	Description
DI		Directivity index of Tonpiliz transducer
DI_fl_pist		Directivity index of flanged piston

- 4 Click to select row number 3 in the table.
- 5 Click  **Delete**.
- 6 Locate the **Legends** section. From the **Legends** list, choose **Automatic**.
- 7 In the **Directivity Index (DI)** toolbar, click  **Plot**.

#### *Transmitting Voltage Response*

Duplicate the previous plot group and modify it to total radiated power like in [Figure 15](#).

#### *Total Radiated Power*

- 1 In the **Model Builder** window, right-click **Transmitting Voltage Response** and choose **Duplicate**.
- 2 In the **Settings** window for **ID Plot Group**, type **Total Radiated Power** in the **Label** text field.

- 3 Locate the **Plot Settings** section. Clear the **y-axis label** checkbox.
- 4 Locate the **Legend** section. From the **Position** list, choose **Upper left**.

#### *Global 1*

- 1 In the **Model Builder** window, expand the **Total Radiated Power** node, then click **Global 1**.
- 2 In the **Settings** window for **Global**, locate the **y-Axis Data** section.
- 3 In the table, enter the following settings:

Expression	Unit	Description
Ptot	mW	Total radiated power

- 4 In the **Total Radiated Power** toolbar, click  **Plot**.  
Create a grid dataset in order to plot the exterior-field pressure  $p_{ext}(x, y, z)$  outside of the computational mesh. This will reproduce [Figure 16](#).

#### *Grid 3D 1*

- 1 In the **Results** toolbar, click  **More Datasets** and choose **Grid > Grid 3D**.
- 2 In the **Settings** window for **Grid 3D**, locate the **Parameter Bounds** section.
- 3 Find the **First parameter** subsection. In the **Maximum** text field, type 0.
- 4 Find the **Second parameter** subsection. In the **Minimum** text field, type -200.
- 5 In the **Maximum** text field, type 200.
- 6 Find the **Third parameter** subsection. In the **Maximum** text field, type -200.
- 7 Click to expand the **Grid** section. In the **x resolution** text field, type 2.
- 8 In the **y resolution** text field, type 150.
- 9 In the **z resolution** text field, type 150.

#### *Exterior Pressure Slice*



- 1 In the **Results** toolbar, click  **3D Plot Group**.
- 2 In the **Settings** window for **3D Plot Group**, type Exterior Pressure Slice in the **Label** text field.

#### *Surface 1*

- 1 Right-click **Exterior Pressure Slice** and choose **Surface**.
- 2 In the **Settings** window for **Surface**, locate the **Data** section.
- 3 From the **Dataset** list, choose **Grid 3D 1**.

- 4 Locate the **Expression** section. In the **Expression** text field, type  $\text{if}(\sqrt{x^2+y^2+z^2} > R_{\text{water}}, \text{pext}(x, y, z), \text{NaN})$ .

The  $\text{if}()$  statement ensures that  $\text{pext}(x, y, z)$  is only plotted outside of the exterior-field calculation boundary where it makes mathematical sense to do so. The value NaN will plot nothing.

- 5 In the **Exterior Pressure Slice** toolbar, click  **Plot**.
- 6 Click the  **Go to YZ View** button in the **Graphics** toolbar.

Now, create a second plot that represents the sound pressure level outside of the transducer and reproduce [Figure 17](#). The SPL is also plotted inside the transducer.

#### *Exterior SPL Slice*

- 1 In the **Results** toolbar, click  **3D Plot Group**.
- 2 In the **Settings** window for **3D Plot Group**, type **Exterior SPL Slice** in the **Label** text field.
- 3 Locate the **Data** section. From the **Parameter value (freq (kHz))** list, choose **20**.

#### *Surface 1*

- 1 Right-click **Exterior SPL Slice** and choose **Surface**.
- 2 In the **Settings** window for **Surface**, locate the **Data** section.
- 3 From the **Dataset** list, choose **Grid 3D 1**.
- 4 From the **Parameter value (freq (kHz))** list, choose **20**.
- 5 Locate the **Expression** section. In the **Expression** text field, type  $\text{if}(\sqrt{x^2+y^2+z^2} > R_{\text{water}}, \text{acpr}.\text{efc1}.\text{Lp\_pext}, \text{NaN})$ .
- 6 Locate the **Coloring and Style** section. From the **Color table** list, choose **Rainbow**.
- 7 From the **Scale** list, choose **Linear**.

#### *Slice 1*

- 1 In the **Model Builder** window, right-click **Exterior SPL Slice** and choose **Slice**.
- 2 In the **Settings** window for **Slice**, locate the **Expression** section.
- 3 In the **Expression** text field, type  $\text{acpr}.\text{Lp\_t}$ .
- 4 Locate the **Plane Data** section. In the **Planes** text field, type **1**.
- 5 Click to expand the **Inherit Style** section. From the **Plot** list, choose **Surface 1**.

Add a selection to the slice plot such that variables are not plotted in the PML domain. Use it to also plot the SPL inside the computational domain.

*Selection 1*

**1** Right-click **Slice 1** and choose **Selection**.

**2** Select Domains 3–20, 22–30, and 32–40 only.

You have selected all domains except the PML domains. Simply select all domains (use Ctrl+A) and then deselect the PML.

**3** In the **Exterior SPL Slice** toolbar, click  **Plot**.