



Model created in COMSOL Multiphysics 6.4

# Test Bench Car Interior

## Introduction

---

In this application, a point source generates a pressure wave in the Sound Brick, a test bench car interior (Ref. 1). The sound pressure level is measured at another point and at a range of frequencies high enough that a good mesh resolution is required to properly resolve the wave. To get an idea of the accuracy of the model, the sound pressure level response is studied using four different mesh resolutions.

## Model Definition

---

The geometrical and material parameters in this model come from Ref. 2. The geometry of the Sound Brick is shown in Figure 1. The model solves for the acoustic pressure  $p$  in the frequency domain using the Pressure Acoustics, Frequency Domain interface.

A monopole point flow source of strength  $Q_S = 10^{-5} \text{ m}^3/\text{s}$  located at the point  $\mathbf{R}_0 = (0.21, 0, 1.28)$  drives the system. The walls of the Sound Brick are assumed to be perfectly reflecting and have the default sound hard boundary condition. The sound pressure level is measured at the point  $\mathbf{R}_1 = (1.34, 1.22, 0.8)$  at a range of frequencies from 743 Hz to 745 Hz.

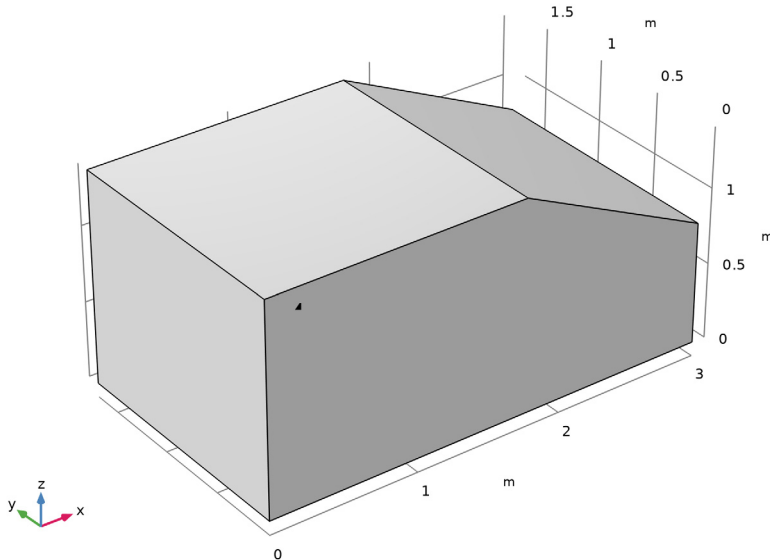

Figure 1: The geometry of the test bench car interior.

The dimensions of the test bench car are length  $\times$  height  $\times$  depth = 3.0 m  $\times$  1.4 m  $\times$  1.7 m. The windshield has its lower end 0.8 m above the floor and with an inclination such that the entire volume of the geometry is 6.5 m<sup>3</sup>.

## Results and Discussion

Figure 2 shows the instantaneous pressure distribution in the car interior at 745 Hz.

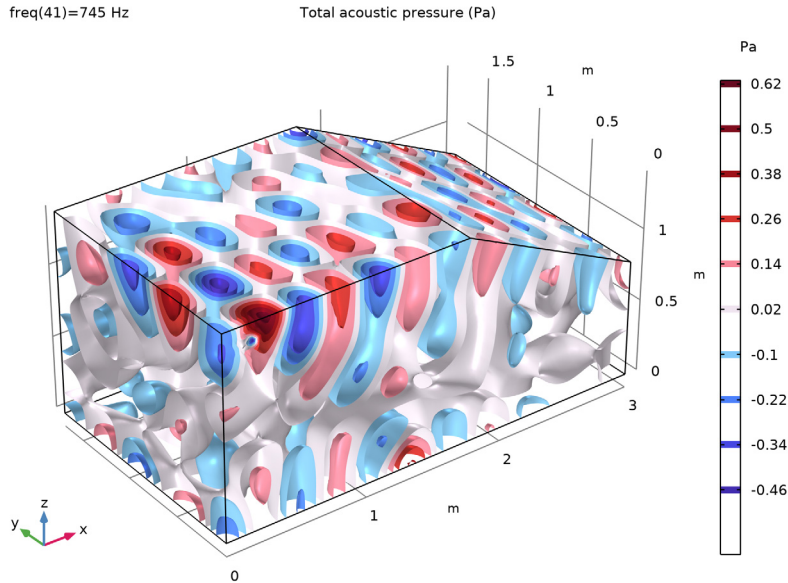

Figure 2: Isosurface plot of the pressure distribution at 745 Hz, for the coarsest one of the 4 meshes used in the model.

A direct comparison of the computational results with those published in Ref. 2 is difficult for two reasons:

- The sampling frequency is too small to resolve some of the resonances at the higher frequencies
- The amplitude for the point source is not given

Nevertheless, it is possible to examine the accuracy of the results by studying how they converge when using successively greater mesh resolutions.

To provide an idea of the accuracy of the various solutions, Figure 3 shows the measured sound pressure level between 743 Hz and 745 Hz, computed at 0.005 Hz intervals for

the listed mesh resolutions. The plot can be reproduced by changing the frequency resolution from 0.05 Hz to 0.005 Hz when following the [Modeling Instructions](#). As you can see in the plot, all the curves follow each other except at the dips and peaks, where the curves predict slightly different frequencies for the resonances. This is an idealized setup where there is no sources of damping, so a perfect resolution in space and time would result in infinite sound levels in the peaks and absolutely no sound in the dips. In real-life applications, the extremes would be much less pronounced than in the plot because the sound sources are rarely point-like and the walls are usually not perfectly reflecting. In such cases, you can expect a similar solution accuracy at the peaks and the dips as in between them.

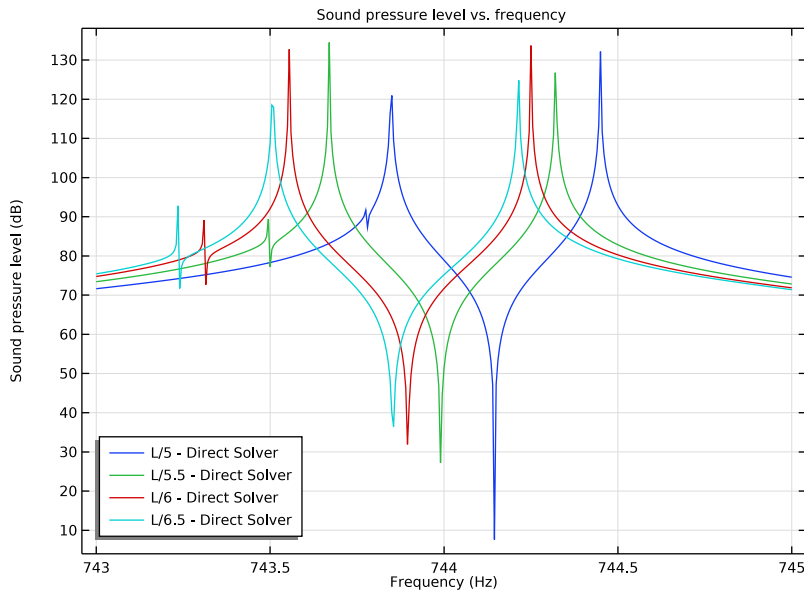

*Figure 3: Sound pressure level (dB) at the point of measurement as a function of frequency (Hz) for a few different mesh densities. The legend shows the maximum mesh element size in fractions of the wavelength  $L$ .*

### *Notes about Modeling in COMSOL Multiphysics*

In general, 5 to 6 second-order elements per wavelength are needed to resolve the waves. In the case treated in the step-by-step instructions, you generate the initial mesh by specifying a maximum element size of  $\lambda/5$ , where  $\lambda = c/f$  is the free-space wavelength of the sound waves at 745 Hz. After showing how you to set up, run, and analyze the model with this mesh, the instructions take you through the mesh convergence study. As it is seen

from this model, depending on the level of accuracy desired, 5 second-order elements per wavelength is not always fine enough to get accurate resonances. When a model has sharp resonances or it has small geometry details, the mesh should be finer. Therefore it is always recommended to do a mesh convergence study when performing simulations, as is done in this model. Moreover, as it is clear from this model, having a fine enough frequency resolution is also important as it is clear that the two solutions match well between the resonances.

---

**Note:** It is good simulation practice to perform a mesh convergence analysis to be sure that the obtained results have converged.

---

### *References*

---

1. The Sound Brick is located in Acoustic Competence Centre, Graz, Austria  
[http://portal.tugraz.at/portal/page/portal/TU\\_Graz](http://portal.tugraz.at/portal/page/portal/TU_Graz)
2. A. Hepberger, H. Priebisch, W. Desmet, B. Van Hal, B. Pluymers, and P. Sas, “Application of the Wave-Based Method for the Steady-state Acoustic Response Prediction of a Car Cavity in the Mid-frequency Range,” *Proceedings of the International Conference on Noise and Vibration Engineering, ISMA2002*, Leuven, Belgium, pp. 877–884, 2002.

---

**Application Library path:** Acoustics\_Module/Automotive/  
test\_bench\_car\_interior

---

### *Modeling Instructions*

---



From the **File** menu, choose **New**.

#### **NEW**

In the **New** window, click  **Model Wizard**.

#### **MODEL WIZARD**

I In the **Model Wizard** window, click  **3D**.

- 2 In the **Select Physics** tree, select **Acoustics > Pressure Acoustics > Pressure Acoustics, Frequency Domain (acpr)**.
- 3 Click **Add**.
- 4 Click  **Study**.
- 5 In the **Select Study** tree, select **General Studies > Frequency Domain**.
- 6 Click  **Done**.

## GLOBAL DEFINITIONS

Now, either enter the parameters used for the model manually or load them from the file `test_bench_car_interior_parameters.txt`.

### Parameters 1

- 1 In the **Model Builder** window, under **Global Definitions** click **Parameters 1**.
- 2 In the **Settings** window for **Parameters**, locate the **Parameters** section.
- 3 In the table, enter the following settings:



Name	Expression	Value	Description
rho0	1.2[kg/m^3]	1.2 kg/m <sup>3</sup>	Air density
c0	343.8[m/s]	343.8 m/s	Speed of sound in air
f0	745[Hz]	745 Hz	Highest frequency used in the model
L	c0/f0	0.46148 m	Shortest wavelength
S	1e-5[m^3/s]	1E-5 m <sup>3</sup> /s	Flow source strength

You will use L, the wavelength corresponding to the highest frequency, when defining the mesh size.

Import the geometry of the test bench car interior from a file.

## GEOMETRY 1

### Import 1 (imp1)

- 1 In the **Geometry** toolbar, click  **Import**.
- 2 In the **Settings** window for **Import**, locate the **Source** section.
- 3 Click  **Browse**.
- 4 Browse to the model's Application Libraries folder and double-click the file `test_bench_car_interior.mphbin`.

5 Click  **Import**.

Create two points, one for the source and one for the receiver.



*Point 1 (pt1)*

- 1 In the **Geometry** toolbar, click  **More Primitives** and choose **Point**.
- 2 In the **Settings** window for **Point**, locate the **Point** section.
- 3 In the **x** text field, type 0.21.
- 4 In the **z** text field, type 1.28.

*Point 2 (pt2)*

- 1 In the **Geometry** toolbar, click  **More Primitives** and choose **Point**.
- 2 In the **Settings** window for **Point**, locate the **Point** section.
- 3 In the **x** text field, type 1.34.
- 4 In the **y** text field, type 1.22.
- 5 In the **z** text field, type 0.8.

*Form Union (fin)*

- 1 In the **Model Builder** window, click **Form Union (fin)**.
- 2 In the **Settings** window for **Form Union/Assembly**, click  **Build Selected**.
- 3 Click the  **Zoom Extents** button in the **Graphics** toolbar.

**MATERIALS**

*Material 1 (mat1)*

- 1 In the **Model Builder** window, under **Component 1 (comp1)** right-click **Materials** and choose **Blank Material**.
- 2 Select Domain 1 only.
- 3 In the **Settings** window for **Material**, locate the **Material Contents** section.
- 4 In the table, enter the following settings:

Property	Variable	Value	Unit	Property group
Density	rho	rho0	kg/m <sup>3</sup>	Basic
Speed of sound	c	c0	m/s	Basic

**PRESSURE ACOUSTICS, FREQUENCY DOMAIN (ACPR)**

- 1 In the **Model Builder** window, under **Component 1 (comp1)** click **Pressure Acoustics, Frequency Domain (acpr)**.

- 2 In the **Settings** window for **Pressure Acoustics, Frequency Domain**, click to expand the **Discretization** section.
- 3 From the **Element order** list, choose **Quadratic serendipity**.

#### *Monopole Point Source 1*

- 1 In the **Physics** toolbar, click  **Points** and choose **Monopole Point Source**.
- 2 Select Point 5 only.  
Point 5 is the one on the geometry's front wall.
- 3 In the **Settings** window for **Monopole Point Source**, locate the **Monopole Point Source** section.
- 4 In the  $Q_S$  text field, type  $i*S$ .  
Introducing a phase shift by multiplying the source strength with the imaginary unit gives nonzero pressure plots at the default zero value for the complex pressure variable's phase. You can also here simply enter  $S$  in the  $Q_S$  text field and then enter  $\pi/2$  for the phase  $\phi$ .

#### **MESH 1 - L/5**

In general, 5 to 6 second-order elements per wavelength are needed to resolve the waves. For more details, see *Meshing (Resolving the Waves)* in the *Acoustics Module User's Guide*. In this model, start by using 5 elements per wavelength and set up the mesh manually to get a structured swept mesh. This will lead to fewer degrees of freedom to be solved for. Proceed by directly adding the desired mesh component.

- 1 In the **Model Builder** window, under **Component 1 (comp1)** click **Mesh 1**.
- 2 In the **Settings** window for **Mesh**, type Mesh 1 - L/5 in the **Label** text field.

#### *Swept 1*



In the **Mesh** toolbar, click  **Swept**.

#### *Size*

- 1 In the **Model Builder** window, click **Size**.
- 2 In the **Settings** window for **Size**, locate the **Element Size** section.
- 3 Click the **Custom** button.
- 4 Locate the **Element Size Parameters** section. In the **Maximum element size** text field, type L/5.

#### *Swept 1*

- 1 In the **Model Builder** window, click **Swept 1**.



- 2 In the **Settings** window for **Swept**, click to expand the **Source Faces** section.
- 3 Click to select the  **Activate Selection** toggle button.
- 4 Select Boundary 2 only.
- 5 Click  **Build All**.

## STUDY 1

### *Step 1: Frequency Domain*

- 1 In the **Model Builder** window, under **Study 1** click **Step 1: Frequency Domain**.
- 2 In the **Settings** window for **Frequency Domain**, locate the **Study Settings** section.
- 3 In the **Frequencies** text field, type range (f0-2, 0.05, f0).
- 4 In the **Model Builder** window, click **Study 1**.
- 5 In the **Settings** window for **Study**, type Study 1 - L/5 - Direct Solver in the **Label** text field.

### *Solution 1 (sol1)*

- 1 In the **Study** toolbar, click  **Show Default Solver**.
- 2 In the **Model Builder** window, expand the **Solution 1 (sol1)** node.  
Enabling the **Block low rank factorization** will reduce both running time and memory consumption. This option is good for pressure acoustics models that do not include nonlocal couplings.
- 3 In the **Model Builder** window, expand the **Study 1 - L/5 - Direct Solver > Solver Configurations > Solution 1 (sol1) > Stationary Solver 1** node, then click **Suggested Direct Solver (acpr)**.
- 4 In the **Settings** window for **Direct**, locate the **General** section.
- 5 Select the **Block low rank factorization** checkbox.
- 6 In the **Study** toolbar, click  **Compute**.

## RESULTS

### Acoustic Pressure (acpr)

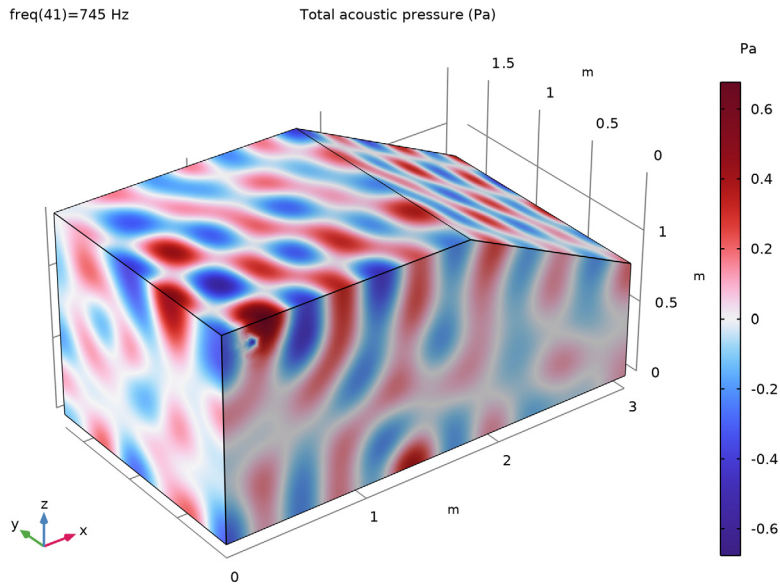

The first two of the default plots show the pressure and sound pressure level distributions on the walls of the car at 500 Hz. The third plot gives a closer look at the standing waves inside the car in the form of isosurfaces for the pressure (see [Figure 2](#)).

### Acoustic Pressure, Isosurfaces (acpr)

Proceed to group the plots to facilitate the navigation through the results.

### Acoustic Pressure (acpr), Acoustic Pressure, Isosurfaces (acpr), Sound Pressure Level (acpr)

**1** In the **Model Builder** window, under **Results**, Ctrl-click to select **Acoustic Pressure (acpr)**, **Sound Pressure Level (acpr)**, and **Acoustic Pressure, Isosurfaces (acpr)**.

**2** Right-click and choose **Group**.

### Results - L/5 - Direct Solver

In the **Settings** window for **Group**, type Results - L/5 - Direct Solver in the **Label** text field.

### ID Plot Group 4

**1** In the **Results** toolbar, click  **ID Plot Group**.

- 2 In the **Settings** window for **ID Plot Group**, click to expand the **Title** section.
- 3 From the **Title type** list, choose **Manual**.
- 4 In the **Title** text area, type Sound pressure level vs. frequency.

#### *Point Graph 1*

- 1 Right-click **ID Plot Group 4** and choose **Point Graph**.
- 2 Click the  **Wireframe Rendering** button in the **Graphics** toolbar.
- 3 Select Point 6 only.  
Wireframe rendering makes it easier to select Point 6, which is in the interior of the car.
- 4 In the **Settings** window for **Point Graph**, click **Replace Expression** in the upper-right corner of the **y-Axis Data** section. From the menu, choose **Component 1 (comp1) > Pressure Acoustics, Frequency Domain > Pressure and sound pressure level > acpr.Lp\_t - Total sound pressure level - dB**.
- 5 Click **Replace Expression** in the upper-right corner of the **x-Axis Data** section. From the menu, choose **Component 1 (comp1) > Pressure Acoustics, Frequency Domain > Global > acpr.freq - Frequency - Hz**.
- 6 Click to expand the **Legends** section. Select the **Show legends** checkbox.
- 7 From the **Legends** list, choose **Manual**.
- 8 In the table, enter the following settings:

---

#### **Legends**

---

L/5 - Direct Solver

---

- 9 In the **ID Plot Group 4** toolbar, click  **Plot**.

This concludes the coarse mesh version of the model. The rest of the instructions show you how to perform a mesh convergence study, by repeating the solution procedure with three consecutively finer meshes and comparing the results. The approach in this model is useful if you want to keep all the results in the model and easily compare them afterward. However, if you systematically want to process solutions on many different meshes or geometries, a batch run would be more convenient, as it avoids the need to perform any of the settings more than once.

To prepare for your convergence study, start by creating the meshes. Each one should have a successively smaller maximum element size.

#### **MESH 2 - L/5.5**

- 1 In the **Mesh** toolbar, click **Add Mesh** and choose **Add Mesh**.

2 In the **Settings** window for **Mesh**, type Mesh 2 - L/5.5 in the **Label** text field.

*Swept 1*

In the **Mesh** toolbar, click  **Swept**.

*Size*

1 In the **Model Builder** window, click **Size**.

2 In the **Settings** window for **Size**, locate the **Element Size Parameters** section.

3 In the **Maximum element size** text field, type L/5.5.

*Swept 1*

1 In the **Model Builder** window, click **Swept 1**.

2 In the **Settings** window for **Swept**, locate the **Source Faces** section.

3 Click to select the  **Activate Selection** toggle button.

4 Select Boundary 2 only.

### **MESH 3 - L/6**

1 In the **Mesh** toolbar, click **Add Mesh** and choose **Add Mesh**.

2 In the **Settings** window for **Mesh**, type Mesh 3 - L/6 in the **Label** text field.

3 In the **Mesh** toolbar, click  **Swept**.

*Size*

1 In the **Model Builder** window, under **Component 1 (comp1) > Meshes > Mesh 3 - L/6** click **Size**.

2 In the **Settings** window for **Size**, locate the **Element Size Parameters** section.

3 In the **Maximum element size** text field, type L/6.

*Swept 1*

1 In the **Model Builder** window, click **Swept 1**.

2 In the **Settings** window for **Swept**, locate the **Source Faces** section.

3 Click to select the  **Activate Selection** toggle button.

4 Select Boundary 2 only.

### **MESH 4 - L/6.5**

1 In the **Mesh** toolbar, click **Add Mesh** and choose **Add Mesh**.

2 In the **Settings** window for **Mesh**, type Mesh 4 - L/6.5 in the **Label** text field.

3 In the **Mesh** toolbar, click  **Swept**.



### Size

- 1 In the **Model Builder** window, under **Component 1 (comp1) > Meshes > Mesh 4 - L/6.5** click **Size**.
- 2 In the **Settings** window for **Size**, locate the **Element Size Parameters** section.
- 3 In the **Maximum element size** text field, type L/6.5.

### Swept 1

- 1 In the **Model Builder** window, click **Swept 1**.
- 2 In the **Settings** window for **Swept**, locate the **Source Faces** section.
- 3 Click to select the  **Activate Selection** toggle button.
- 4 Select Boundary 2 only.

### ADD STUDY

- 1 In the **Home** toolbar, click  **Add Study** to open the **Add Study** window.
- 2 Go to the **Add Study** window.
- 3 Find the **Studies** subsection. In the **Select Study** tree, select **General Studies > Frequency Domain**.
- 4 Click the **Add Study** button in the window toolbar.
- 5 In the **Select Study** tree, select **General Studies > Frequency Domain**.
- 6 Click the **Add Study** button in the window toolbar.
- 7 In the **Select Study** tree, select **General Studies > Frequency Domain**.
- 8 Click the **Add Study** button in the window toolbar.
- 9 In the **Home** toolbar, click  **Add Study** to close the **Add Study** window.

### STUDY 2

#### Step 1: Frequency Domain

- 1 In the **Settings** window for **Frequency Domain**, click to expand the **Mesh Selection** section.
- 2 In the table, enter the following settings:

Component	Mesh
Geometry 1	Mesh 2 - L/5.5

### STUDY 3

- 1 In the **Model Builder** window, under **Study 3** click **Step 1: Frequency Domain**.
- 2 In the **Settings** window for **Frequency Domain**, locate the **Mesh Selection** section.

3 In the table, enter the following settings:

Component	Mesh
Geometry 1	Mesh 3 - L/6

#### STUDY 4

- 1 In the **Model Builder** window, under **Study 4** click **Step 1: Frequency Domain**.
- 2 In the **Settings** window for **Frequency Domain**, locate the **Mesh Selection** section.
- 3 In the table, enter the following settings:

Component	Mesh
Geometry 1	Mesh 4 - L/6.5

#### STUDY 2

- 1 In the **Model Builder** window, under **Study 2** click **Step 1: Frequency Domain**.
- 2 In the **Settings** window for **Frequency Domain**, locate the **Study Settings** section.
- 3 In the **Frequencies** text field, type range (f0-2, 0.05, f0).

#### STUDY 3

- 1 In the **Model Builder** window, under **Study 3** click **Step 1: Frequency Domain**.
- 2 In the **Settings** window for **Frequency Domain**, locate the **Study Settings** section.
- 3 In the **Frequencies** text field, type range (f0-2, 0.05, f0).

#### STUDY 4

- 1 In the **Model Builder** window, under **Study 4** click **Step 1: Frequency Domain**.
- 2 In the **Settings** window for **Frequency Domain**, locate the **Study Settings** section.
- 3 In the **Frequencies** text field, type range (f0-2, 0.05, f0).

Having set up a Frequency Domain study step for each study, you are now ready to start the solution process. The first solution already exists, so start by solving the second one.

#### STUDY 2 - L/5.5 - DIRECT SOLVER

- 1 In the **Model Builder** window, click **Study 2**.
- 2 In the **Settings** window for **Study**, type Study 2 - L/5.5 - Direct Solver in the **Label** text field.

*Solution 2 (sol2)*

- 1 In the **Study** toolbar, click  **Show Default Solver**.

- 2 In the **Model Builder** window, expand the **Solution 2 (sol2)** node.
- 3 In the **Model Builder** window, expand the **Study 2 - L/5.5 - Direct Solver > Solver Configurations > Solution 2 (sol2) > Stationary Solver 1** node, then click **Suggested Direct Solver (acpr)**.
- 4 In the **Settings** window for **Direct**, locate the **General** section.
- 5 Select the **Block low rank factorization** checkbox.
- 6 In the **Study** toolbar, click  **Compute**.

## RESULTS

### *Acoustic Pressure (acpr) 1*

When the solver is done, three more plots will appear, this time for the second one of your meshes. Group these plots as you did with the previous results to facilitate the navigation through the results. Then, proceed to solve for the next mesh.

### *Acoustic Pressure (acpr) 1, Acoustic Pressure, Isosurfaces (acpr) 1, Sound Pressure Level (acpr) 1*

- 1 In the **Model Builder** window, under **Results**, Ctrl-click to select **Acoustic Pressure (acpr) 1, Sound Pressure Level (acpr) 1, and Acoustic Pressure, Isosurfaces (acpr) 1**.
- 2 Right-click and choose **Group**.

### *Results - L/5.5 - Direct Solver*

In the **Settings** window for **Group**, type Results - L/5.5 - Direct Solver in the **Label** text field.

## STUDY 3 - L/6 - DIRECT SOLVER

- 1 In the **Model Builder** window, click **Study 3**.
- 2 In the **Settings** window for **Study**, type Study 3 - L/6 - Direct Solver in the **Label** text field.

### *Solution 3 (sol3)*

- 1 In the **Study** toolbar, click  **Show Default Solver**.
- 2 In the **Model Builder** window, expand the **Solution 3 (sol3)** node.
- 3 In the **Model Builder** window, expand the **Study 3 - L/6 - Direct Solver > Solver Configurations > Solution 3 (sol3) > Stationary Solver 1** node, then click **Suggested Direct Solver (acpr)**.
- 4 In the **Settings** window for **Direct**, locate the **General** section.

5 Select the **Block low rank factorization** checkbox.

6 In the **Study** toolbar, click  **Compute**.

## RESULTS

*Acoustic Pressure, Isosurfaces (acpr) 1*

Group these results.

*Acoustic Pressure (acpr) 2, Acoustic Pressure, Isosurfaces (acpr) 2, Sound Pressure Level (acpr) 2*

1 In the **Model Builder** window, under **Results**, Ctrl-click to select

**Acoustic Pressure (acpr) 2, Sound Pressure Level (acpr) 2, and Acoustic Pressure, Isosurfaces (acpr) 2.**

2 Right-click and choose **Group**.

*Results - L/6 - Direct Solver*

In the **Settings** window for **Group**, type Results - L/6 - Direct Solver in the **Label** text field.

Finally, solve for the finest mesh case.

## STUDY 4 - L/6.5 - DIRECT SOLVER

1 In the **Model Builder** window, click **Study 4**.

2 In the **Settings** window for **Study**, type Study 4 - L/6.5 - Direct Solver in the **Label** text field.

*Solution 4 (sol4)*

1 In the **Study** toolbar, click  **Show Default Solver**.

2 In the **Model Builder** window, expand the **Solution 4 (sol4)** node.

3 In the **Model Builder** window, expand the **Study 4 - L/6.5 - Direct Solver > Solver Configurations > Solution 4 (sol4) > Stationary Solver 1** node, then click **Suggested Direct Solver (acpr)**.

4 In the **Settings** window for **Direct**, locate the **General** section.

5 Select the **Block low rank factorization** checkbox.

6 In the **Study** toolbar, click  **Compute**.

Group these results.

## RESULTS

*Acoustic Pressure (acpr) 3, Acoustic Pressure, Isosurfaces (acpr) 3, Sound Pressure Level (acpr) 3*

Right-click and choose **Group**.

*Results - L/6.5 - Direct Solver*

In the **Settings** window for **Group**, type Results - L/6.5 - Direct Solver in the **Label** text field.

*ID Plot Group 4*

1 In the **Model Builder** window, click **ID Plot Group 4**.

2 Drag and drop below **Results - L/6.5 - Direct Solver**.

*Point Graph 2*

1 In the **Model Builder** window, under **Results > ID Plot Group 4** right-click **Point Graph 1** and choose **Duplicate**.

2 In the **Settings** window for **Point Graph**, locate the **Data** section.

3 From the **Dataset** list, choose **Study 2 - L/5.5 - Direct Solver/Solution 2 (sol2)**.

4 Locate the **Legends** section. In the table, enter the following settings:

---

<b>Legends</b>
L/5.5 - Direct Solver

---

*Point Graph 3*

1 Right-click **Point Graph 2** and choose **Duplicate**.

2 In the **Settings** window for **Point Graph**, locate the **Data** section.

3 From the **Dataset** list, choose **Study 3 - L/6 - Direct Solver/Solution 3 (sol3)**.

4 Locate the **Legends** section. In the table, enter the following settings:

---

<b>Legends</b>
L/6 - Direct Solver

---

*Point Graph 4*

1 Right-click **Point Graph 3** and choose **Duplicate**.

2 In the **Settings** window for **Point Graph**, locate the **Data** section.

3 From the **Dataset** list, choose **Study 4 - L/6.5 - Direct Solver/Solution 4 (sol4)**.

4 Locate the **Legends** section. In the table, enter the following settings:

---

**Legends**

---

L/6.5 - Direct Solver

---

5 In the **ID Plot Group 4** toolbar, click  **Plot**.

*SPL Response*

1 In the **Model Builder** window, under **Results** click **ID Plot Group 4**.

2 In the **Settings** window for **ID Plot Group**, type SPL Response in the **Label** text field.

3 Locate the **Plot Settings** section. Select the **x-axis label** checkbox.

4 Select the **y-axis label** checkbox. In the associated text field, type Sound pressure level (dB).

5 Locate the **Legend** section. From the **Position** list, choose **Lower left**.

6 In the **SPL Response** toolbar, click  **Plot**.

The plot should look like the figure below. A version of the plot with a higher frequency resolution of 0.005 Hz is depicted in [Figure 3](#).

