



Model created in COMSOL Multiphysics 6.4

# Submarine Target Strength

## Introduction

---

The primary defense of a submarine lies in its capacity to remain hidden during operation. As radio waves are strongly absorbed by sea water, sound navigation ranging, or sonar, is one of the main methods used for the detection of submarines. Designers analyze the way acoustic waves are reflected in order to minimize the equivalent reflecting area of the submarine. The target strength, or TS, is a measure of the area of a sonar target. In most submarines, reduction of the backscatter signal is achieved through the application of absorbing materials to the outer surfaces of the submarine.

This tutorial is based on the BeTTSi benchmark submarine (Benchmark Target Echo Strength Simulation) presented in [Ref. 1](#) and [Ref. 2](#). This benchmark geometry, shown in [Figure 1](#), presents features common in modern submarines without representing any actual submarine class.

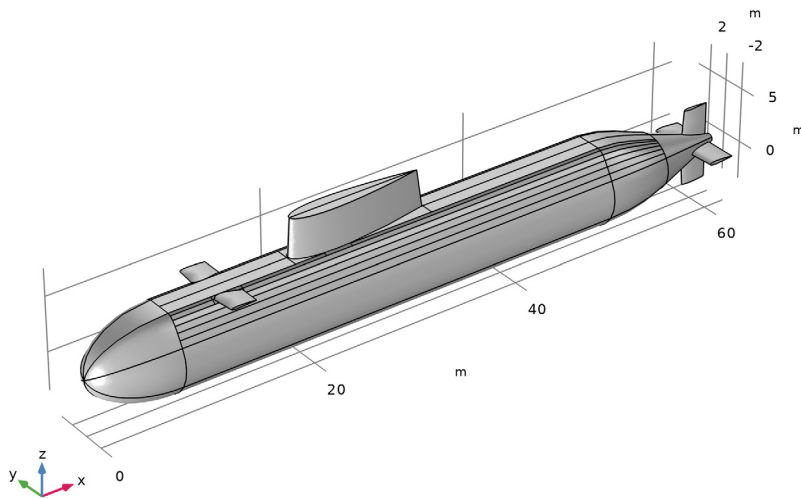

*Figure 1: BeTTSi submarine geometry.*

This model is acoustically large and takes advantage of the stabilized formulation used in the *Pressure Acoustic, Boundary Elements* interface (BEM). The formulation is default and ensures convergence for large models (high frequency or large domains) at the cost of some additional degrees of freedom. The method scales well on cluster configurations.

## Model Definition

---

The model uses the **Background Pressure Field** feature to represent a spherical wave emitted from a distance  $d\_source$  of 1000 m at an angle  $\phi$  of  $330^\circ$  from the bow of the submarine. By the time the waves reach the submarine, they behave locally as plane waves. The **Ocean Attenuation** material model is used to represent the losses existing in the transmitting media. This attenuation model is based on a semianalytical model with parameters that are based on extensive measurement data. It includes effects due to viscosity in pure water, the relaxation processes of boric acid and magnesium sulfate, as well as depth, temperature, salinity (practical), and pH value.

The absorbing material placed on the hard surfaces is represented through the **Absorption coefficient** option in the **Impedance** boundary condition. The feature adds an impedance given by

$$Z_i = \rho_c c_c \frac{1+R}{1-R} \quad R = e^{i\phi} \sqrt{1-\alpha_n} \quad (1)$$

Where  $\rho_c$  is the complex density,  $i$  is the imaginary unit,  $\omega$  is the angular frequency,  $Z_i$  is the specific acoustic input impedance,  $c_c$  is the complex speed of sound,  $R$  is the reflection coefficient,  $\phi$  is the phase, and  $\alpha_n$  is the normal incidence absorption coefficient. In this case, the impedance will be purely resistive, as  $\phi$  is set to 0.

The target strength, or TS, is computed following [Equation 2](#):

$$TS = 20 \log_{10} \left( \frac{p_s d_{\text{listening}}}{p_{\text{in}} 1 \text{ m}} \right) \quad (2)$$

Where  $p_s$  is the scattered pressure at the listening point,  $p_{\text{in}}$  is the background pressure at the submarine and  $d_{\text{listening}}$  is the distance from the submarine to the listening point. As we will use  $d\_source$  as the distance to the listening point, this equation has been modified in the variable definition.

## Results and Discussion

---

[Figure 2](#) shows the total acoustic pressure at the submarine surfaces. Note how the pressure waves are almost planar and how the side of the source “not illuminated” shows

a significantly lower acoustic pressure. Note also the large number of wavelengths considered in the model, this is an acoustically large model.

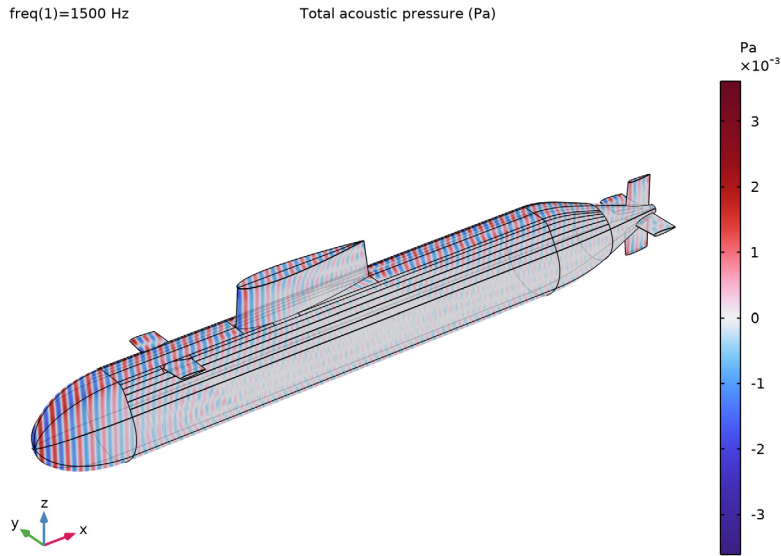

*Figure 2: Total acoustic pressure at the submarine.*

Figure 3 shows the radiation pattern at 100 m away from the submarine. The direction of propagation of the acoustic signal is marked with an arrow. Note the complex lobes that appear at this frequency and how the scattered signal will greatly depend on the actual position where it is measured.

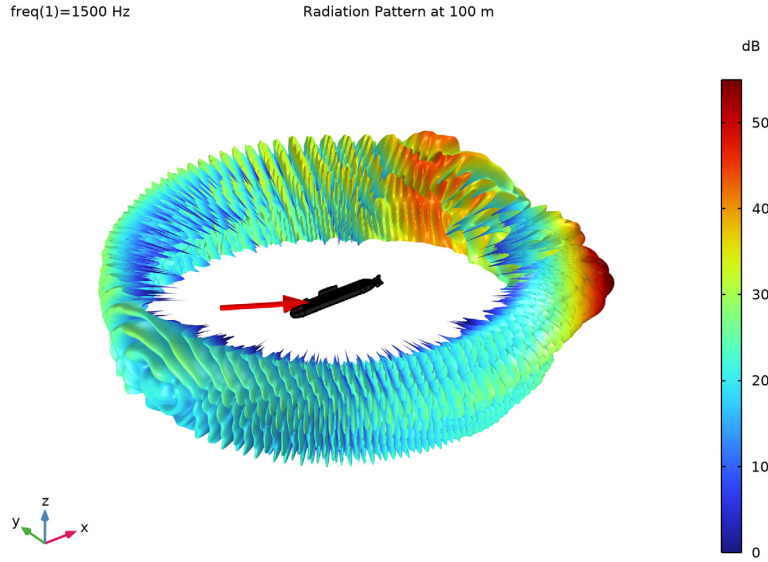

*Figure 3: Radiation pattern 100 m away from the submarine.*

A section cut of the scattered acoustic pressure through the center of the submarine is shown in [Figure 4](#).

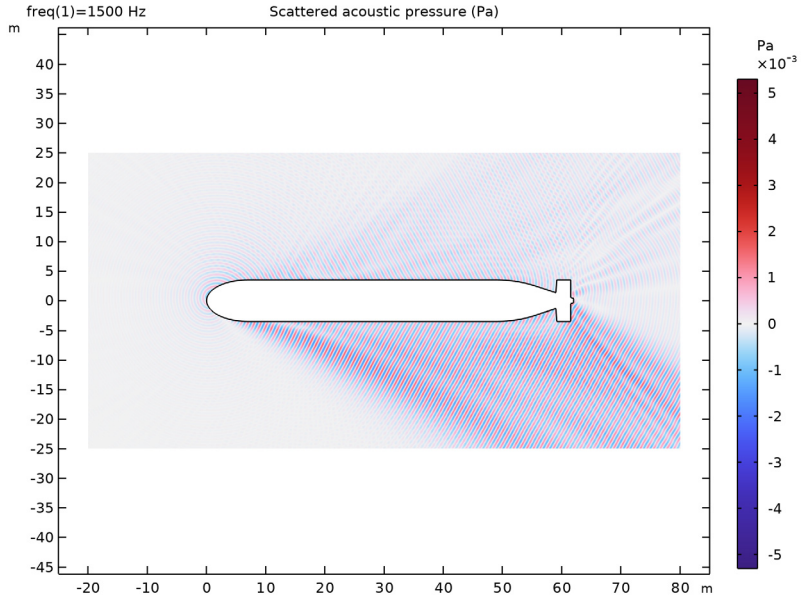

*Figure 4: Section cut of the scattered acoustic pressure.*

Another way to present this is to plot the scattered sound pressure level in the section, as shown in [Figure 5](#).

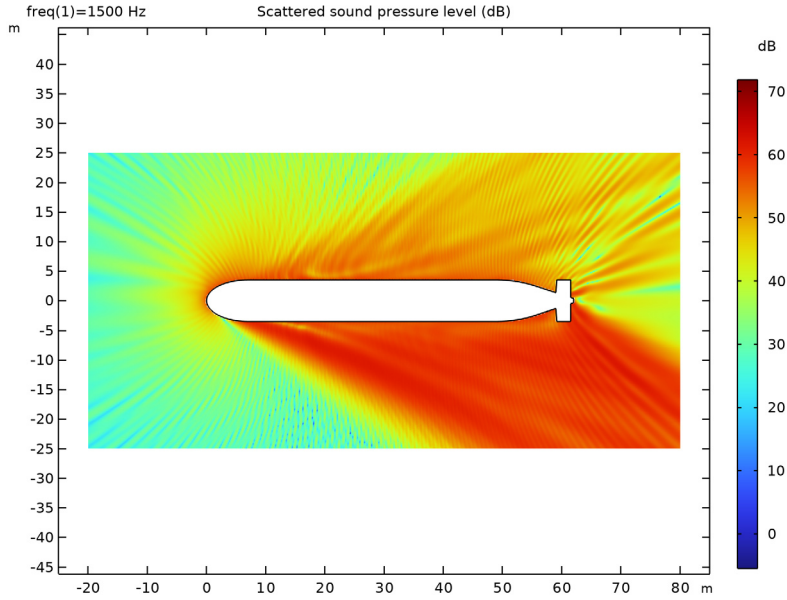

*Figure 5: Section cut of the scattered sound pressure level.*

Figure 6 shows the sound pressure level polar plot around the submarine, that is, the radiation pattern. Note the peaks right below the submarine and at the reflection angle from the source.

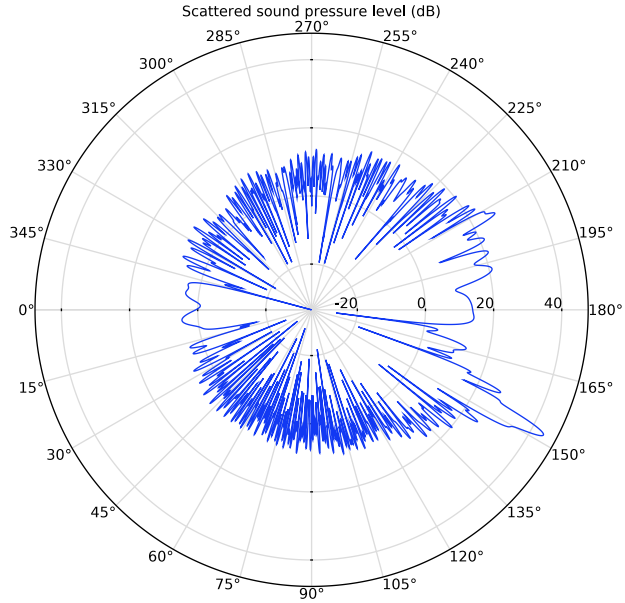

*Figure 6: Polar plot of the sound pressure level.*

Sonar equipment can be run in passive and active configurations. In a passive sonar, the sensor just reflects the sound emitted by the submarine during its operation, while an active source uses some active method to generate an acoustic signal that will be reflected on the submarine. Active sonar can be used in monostatic configurations, when the source and the listening point coincide, or in bistatic configurations, where the position of the source and the listening point are different. The target strength, as defined in [Equation 2](#), for a bistatic configuration is shown in [Figure 7](#).

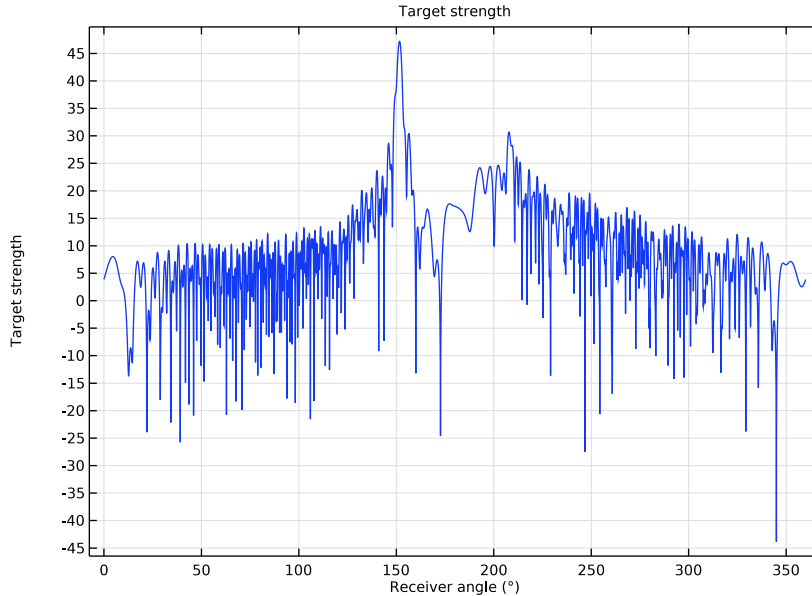

Figure 7: Bistatic target strength of the submarine for a receiver situated at the same distance as the source.

### *Notes About the COMSOL Implementation*

The model uses an MPHBIN file as the starting geometry. It is possible to generate this geometry using COMSOL functionality. The instructions to do so are covered in the [Appendix — Geometry Modeling Instructions](#). Due to the complexity of the geometry and the use of **Cap Face** operations, the generation of the geometry requires the *CAD Import Module* and the *Design Module*. The steps and operations for building the geometry include some geometry information like parameters, coordinates, and curve parameterizations, found in Appendix C of [Ref. 2](#). The steps for building the geometry, using the COMSOL Geometry operations, do differ in some aspects from those in [Ref. 2](#).

### *References*

1. B. Nolte, I. Schäfer, C. de Jong, and L. Gilroy, “BeTSSi II benchmark on target strength simulation,” *Proceedings of Forum Acusticum*, 2014.

2. J.V. Venås and T. Kvamsdal, “Isogeometric boundary element method for acoustic scattering by a submarine,” *Comp. Meth. Appl. Mech. Eng.*, vol. 359, p. 112670, 2020, [doi.org/10.1016/j.cma.2019.112670](https://doi.org/10.1016/j.cma.2019.112670).

---

**Application Library path:** Acoustics\_Module/Underwater\_Acoustics/  
submarine\_target\_strength

---

### *Modeling Instructions*



---

From the **File** menu, choose **New**.

#### **NEW**



In the **New** window, click  **Model Wizard**.

#### **MODEL WIZARD**

- 1 In the **Model Wizard** window, click  **3D**.
- 2 In the **Select Physics** tree, select **Acoustics > Pressure Acoustics > Pressure Acoustics, Boundary Elements (pabe)**.
- 3 Click **Add**.
- 4 Click  **Study**.
- 5 In the **Select Study** tree, select **General Studies > Frequency Domain**.
- 6 Click  **Done**.

#### **GEOMETRY I**

##### *Import 1 (imp1)*



- 1 In the **Geometry** toolbar, click  **Import**.
- 2 In the **Settings** window for **Import**, locate the **Source** section.
- 3 From the **Source** list, choose **COMSOL Multiphysics file**.
- 4 Click  **Browse**.
- 5 Browse to the model’s Application Libraries folder and double-click the file submarine\_target\_strength.mphbin.
- 6 Click  **Import**.

Disable the analysis of the geometry as the remaining small geometric details are needed.

- 7 In the **Model Builder** window, click **Geometry 1**.
- 8 In the **Settings** window for **Geometry**, locate the **Cleanup** section.
- 9 Clear the **Automatic detection of small details** checkbox.
- 10 In the **Geometry** toolbar, click  **Build All**.

To create a better mesh for the front of the submarine, use virtual operations to ignore some edges.

#### *Ignore Edges 1 (ige1)*

- 1 In the **Geometry** toolbar, click  **Virtual Operations** and choose **Ignore Edges**.
- 2 On the object **fin**, select Edges 1, 4–8, and 12–16 only.
- 3 In the **Settings** window for **Ignore Edges**, click  **Build Selected**.  
The geometry should look like [Figure 1](#).

Rename the parameter group and import the parameters from a file.

## GLOBAL DEFINITIONS

### *Model Parameters*

- 1 In the **Model Builder** window, under **Global Definitions** click **Parameters 1**.
- 2 In the **Settings** window for **Parameters**, type Model Parameters in the **Label** text field.
- 3 Locate the **Parameters** section. Click  **Load from File**.
- 4 Browse to the model's Application Libraries folder and double-click the file `submarine_target_strength_parameters.txt`.

The average operator is used to obtain the average incoming pressure over the submarine.

## DEFINITIONS

### *Average 1 (aveop1)*

- 1 In the **Definitions** toolbar, click  **Nonlocal Couplings** and choose **Average**.
- 2 In the **Settings** window for **Average**, locate the **Source Selection** section.
- 3 From the **Geometric entity level** list, choose **Boundary**.
- 4 From the **Selection** list, choose **All boundaries**.

Add new variables that will be used in the postprocessing.



### *Variables 1*

- 1 In the **Model Builder** window, right-click **Definitions** and choose **Variables**.
- 2 In the **Settings** window for **Variables**, locate the **Variables** section.

3 In the table, enter the following settings:

Name	Expression	Unit	Description
TS	$20 \cdot \log_{10}((\text{abs}(\text{pabe.p\_s})/\text{p\_in}) \cdot \text{d\_source}/1[\text{m}])$		Target strength
p_in	$\text{aveop1}(\text{abs}(\text{pabe.p\_b}))$	Pa	Incoming pressure

#### ADD MATERIAL

- 1 In the **Materials** toolbar, click  **Add Material** to open the **Add Material** window.
- 2 Go to the **Add Material** window.
- 3 In the tree, select **Built-in > Water, liquid**.
- 4 Click the **Add to Component** button in the window toolbar.
- 5 In the **Materials** toolbar, click  **Add Material** to close the **Add Material** window.

#### MATERIALS

*Water, liquid (mat1)*

- 1 In the **Settings** window for **Material**, locate the **Geometric Entity Selection** section.
- 2 From the **Selection** list, choose **All voids**.

#### PRESSURE ACOUSTICS, BOUNDARY ELEMENTS (PABE)

- 1 In the **Model Builder** window, under **Component 1 (comp1)** click **Pressure Acoustics, Boundary Elements (pabe)**.
- 2 In the **Settings** window for **Pressure Acoustics, Boundary Elements**, locate the **Domain Selection** section.
- 3 From the **Selection** list, choose **All voids**.
- 4 Locate the **Sound Pressure Level Settings** section. From the **Reference pressure for the sound pressure level** list, choose **Use reference pressure for water**.

Turn on the ocean attenuation model which is specially relevant at high frequencies.

*Pressure Acoustics 1*

- 1 In the **Model Builder** window, under **Component 1 (comp1) > Pressure Acoustics, Boundary Elements (pabe)** click **Pressure Acoustics 1**.
- 2 In the **Settings** window for **Pressure Acoustics**, locate the **Pressure Acoustics Model** section.

- 3 From the **Fluid model** list, choose **Ocean attenuation**.
- 4 Locate the **Model Input** section. In the  $D$  text field, type depth.

#### *Background Pressure Field I*

- 1 In the **Physics** toolbar, click  **Domains** and choose **Background Pressure Field**.

The background field is generated by a source at a distance given by the  $d\_source$  parameter. By the time the spherical waves have reached the target, they locally behave as plane waves.

- 2 In the **Settings** window for **Background Pressure Field**, locate the **Background Pressure Field** section.
- 3 From the **Pressure field type** list, choose **Spherical wave**.
- 4 In the  $p_0$  text field, type  $p\_ref$ .
- 5 Specify the  $\mathbf{x}_0$  vector as

$-d\_source \cdot \cos(\phi)$	x
$-d\_source \cdot \sin(\phi)$	y
0	z

#### *Impedance I*

- 1 In the **Physics** toolbar, click  **Boundaries** and choose **Impedance**.

The submarine uses some anechoic coating to reduce the scattered signal. This absorption coefficient could be specified as frequently dependent, but in this case it takes the value of the  $\alpha_n$  parameter.

- 2 In the **Settings** window for **Impedance**, locate the **Boundary Selection** section.
- 3 From the **Selection** list, choose **All boundaries**.
- 4 Locate the **Impedance** section. From the **Impedance model** list, choose **Absorption coefficient**.
- 5 In the  $\alpha_n$  text field, type  $\alpha\_n$ .

In this model, the mesh is set up manually. Proceed by directly adding the desired mesh component.

#### **MESH I**

As the scattering characteristics are largely influenced by the sail, rudder and bow plane, create a finer mesh around the leading edge of these surfaces. This is achieved by first meshing the necessary edges.

### *Edge 1*

- 1 In the **Mesh** toolbar, click  **More Generators** and choose **Edge**.
- 2 Select Edges 62–65, 185, 186, 188, 189, 191, 192, and 194–203 only.

### *Distribution 1*

- 1 Right-click **Edge 1** and choose **Distribution**.
- 2 In the **Settings** window for **Distribution**, locate the **Distribution** section.
- 3 In the **Number of elements** text field, type 18.

### *Size 1*

- 1 In the **Model Builder** window, right-click **Edge 1** and choose **Size**.
- 2 In the **Settings** window for **Size**, locate the **Element Size** section.
- 3 Click the **Custom** button.
- 4 Locate the **Element Size Parameters** section.
- 5 Select the **Curvature factor** checkbox. In the associated text field, type 0.2.

Set the overall mesh size. For BEM, using 4 elements per wavelength is a good approximation.

### *Size*



- 1 In the **Model Builder** window, under **Component 1 (comp1) > Mesh 1** click **Size**.
- 2 In the **Settings** window for **Size**, locate the **Element Size** section.
- 3 Click the **Custom** button.
- 4 Locate the **Element Size Parameters** section. In the **Maximum element size** text field, type  $1\text{m}/4$ .
- 5 In the **Minimum element size** text field, type 50[mm].

To reduce the computation cost, it is advisable to use a mapped mesh when possible.

### *Mapped 1*



- 1 In the **Mesh** toolbar, click  **More Generators** and choose **Mapped**.
- 2 Select Boundaries 8–25, 30–33, 38–41, 44, 45, 48–50, 53–73, and 80–87 only.

### *Free Triangular 1*

- 1 In the **Mesh** toolbar, click  **More Generators** and choose **Free Triangular**.
- 2 In the **Settings** window for **Free Triangular**, locate the **Boundary Selection** section.
- 3 From the **Geometric entity level** list, choose **Remaining**.
- 4 Click  **Build All**.

Finally, use the **Adapt** feature, from the **Modifying Operations** list, to get a more uniform triangular mesh at the front of the submarine.

#### *Adapt 1*

- 1 In the **Mesh** toolbar, click  **Modify** and choose **Adapt**.
- 2 In the **Settings** window for **Adapt**, locate the **Geometric Entity Selection** section.
- 3 From the **Geometric entity level** list, choose **Boundary**.
- 4 Select Boundaries 1–7 only.
- 5 Locate the **Adaptation** section. In the **Size expression** text field, type  $1\text{m}0/4$ .
- 6 Click  **Build All**.  
The mesh should look like this.
- 7 In the **Model Builder** window, click **Mesh 1**.

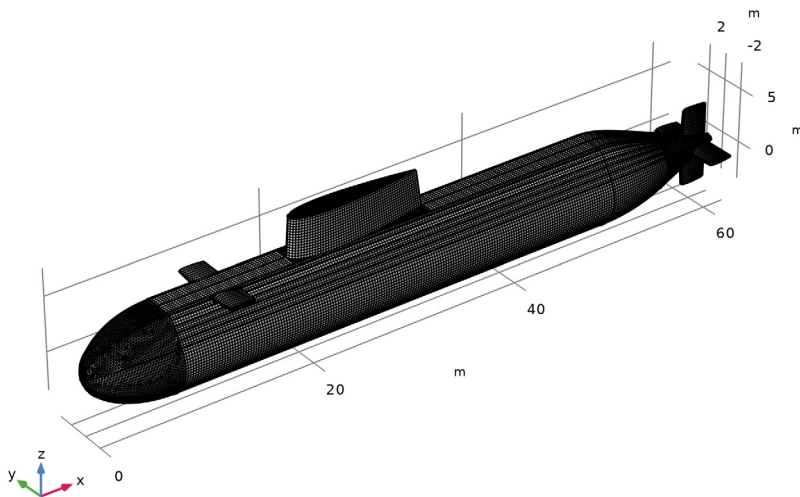

## **STUDY 1**

### *Step 1: Frequency Domain*

- 1 In the **Model Builder** window, under **Study 1** click **Step 1: Frequency Domain**.
- 2 In the **Settings** window for **Frequency Domain**, locate the **Study Settings** section.

- 3 In the **Frequencies** text field, type  $f_{\max}$ .  
The plots will be generated manually.
- 4 In the **Model Builder** window, click **Study I**.
- 5 In the **Settings** window for **Study**, locate the **Study Settings** section.
- 6 Clear the **Generate default plots** checkbox.  
The analysis should take approximately 15 minutes and require 43 GB of RAM. If the computer does not have enough RAM, the running time will be longer as COMSOL will rely on virtual memory.
- 7 In the **Study** toolbar, click  **Compute**.

## RESULTS

- 1 In the **Model Builder** window, click **Results**.
- 2 In the **Settings** window for **Results**, locate the **Update of Results** section.
- 3 Select the **Only plot when requested** checkbox.
- 4 Select the **Recompute all plot data after solving** checkbox.
- 5 Locate the **Save Data in the Model** section. From the **Save plot data** list, choose **On**.

### *Grid 3D 1*

- 1 In the **Model Builder** window, expand the **Results** node.
- 2 Right-click **Results > Datasets** and choose **More 3D Datasets > Grid 3D**.  
This grid will be used to evaluate the solution in the infinite domain surrounding the submarine.
- 3 In the **Settings** window for **Grid 3D**, locate the **Parameter Bounds** section.
- 4 Find the **First parameter** subsection. In the **Minimum** text field, type -20.
- 5 In the **Maximum** text field, type 80.
- 6 Find the **Second parameter** subsection. In the **Minimum** text field, type -25.
- 7 In the **Maximum** text field, type 25.
- 8 Find the **Third parameter** subsection. In the **Minimum** text field, type -0.1.
- 9 In the **Maximum** text field, type 0.1.
- 10 Click to expand the **Grid** section. In the **x resolution** text field, type 500.
- 11 In the **y resolution** text field, type 250.
- 12 In the **z resolution** text field, type 3.



### *Cut Plane 1*

- 1 In the **Results** toolbar, click  **Cut Plane**.
- 2 In the **Settings** window for **Cut Plane**, locate the **Plane Data** section.
- 3 From the **Plane** list, choose **XY-planes**.

### *Cut Plane 2*

- 1 In the **Results** toolbar, click  **Cut Plane**.
- 2 In the **Settings** window for **Cut Plane**, locate the **Data** section.
- 3 From the **Dataset** list, choose **Grid 3D I**.
- 4 Locate the **Plane Data** section. From the **Plane** list, choose **xy-planes**.

### *Parametric Curve 3D 1*



- 1 In the **Results** toolbar, click  **More Datasets** and choose **Parametric Curve 3D**.  
This parametric curve is a circle around the submarine at a distance taken from the `d_source` parameter.
- 2 In the **Settings** window for **Parametric Curve 3D**, locate the **Parameter** section.
- 3 In the **Maximum** text field, type  $2*\pi$ .
- 4 Locate the **Expressions** section. In the **x** text field, type  $-d\_source*\cos(s)$ .
- 5 In the **y** text field, type  $-d\_source*\sin(s)$ .
- 6 Select the **Only evaluate globally defined expressions** checkbox.
- 7 Click to expand the **Resolution** section. In the **Resolution** text field, type 10000.
- 8 Click  **Plot**.
- 9 Click the  **Zoom Extents** button in the **Graphics** toolbar.

### *Total Pressure, Boundaries*

- 1 In the **Results** toolbar, click  **3D Plot Group**.
- 2 In the **Settings** window for **3D Plot Group**, type Total Pressure, Boundaries in the **Label** text field.
- 3 Locate the **Color Legend** section. Select the **Show units** checkbox.

### *Surface 1*

- 1 Right-click **Total Pressure, Boundaries** and choose **Surface**.
- 2 In the **Settings** window for **Surface**, locate the **Expression** section.
- 3 In the **Expression** text field, type `pabe.p_t_bnd`.
- 4 Locate the **Coloring and Style** section. From the **Color table** list, choose **Wave**.
- 5 From the **Scale** list, choose **Linear symmetric**.

- 6 Click to expand the **Quality** section. From the **Evaluation settings** list, choose **Manual**.
- 7 From the **Resolution** list, choose **Extra fine**.
- 8 Click the  **Show Grid** button in the **Graphics** toolbar.
- 9 In the **Total Pressure, Boundaries** toolbar, click  **Plot**.
- 10 Click the  **Zoom Extents** button in the **Graphics** toolbar.

The plot should look like [Figure 2](#).

#### *Radiation Pattern at 100 m*

- 1 In the **Model Builder** window, right-click **Total Pressure, Boundaries** and choose **Duplicate**.
- 2 In the **Model Builder** window, click **Total Pressure, Boundaries 1**.
- 3 In the **Settings** window for **3D Plot Group**, type Radiation Pattern at 100 m in the **Label** text field.
- 4 Locate the **Plot Settings** section. From the **View** list, choose **New view**.
- 5 Click to expand the **Title** section. From the **Title type** list, choose **Label**.

#### *Surface 1*

- 1 In the **Model Builder** window, click **Surface 1**.
- 2 In the **Settings** window for **Surface**, locate the **Expression** section.
- 3 In the **Expression** text field, type 0.
- 4 Click the  **Show Grid** button in the **Graphics** toolbar.
- 5 Click to expand the **Title** section. From the **Title type** list, choose **None**.

#### *Material Appearance 1*

- 1 Right-click **Surface 1** and choose **Material Appearance**.
- 2 In the **Settings** window for **Material Appearance**, locate the **Appearance** section.
- 3 From the **Appearance** list, choose **Custom**.
- 4 From the **Material type** list, choose **Carbon (forged)**.
- 5 In the **Radiation Pattern at 100 m** toolbar, click  **Plot**.

#### *Radiation Pattern at 100 m*

In the **Model Builder** window, under **Results** click **Radiation Pattern at 100 m**.

#### *Radiation Pattern 1*



- 1 In the **Radiation Pattern at 100 m** toolbar, click  **More Plots** and choose **Radiation Pattern**.
- 2 In the **Settings** window for **Radiation Pattern**, locate the **Expression** section.

- 3 In the **Expression** text field, type  $100[m]+pabe.Lp_s[m]$ .
- 4 Select the **Description** checkbox. In the associated text field, type **Scattered sound pressure level at 100[m]**.
- 5 Clear the **Use as color expression** checkbox.
- 6 Locate the **Color** section. In the **Expression** text field, type  $pabe.Lp_s$ .
- 7 Click to expand the **Range** section. Select the **Manual color range** checkbox.
- 8 In the **Minimum** text field, type 0.
- 9 In the **Maximum** text field, type 55.
- 10 Locate the **Evaluation** section. Find the **Angles** subsection. In the **Number of elevation angles** text field, type 120.
- 11 In the **Number of azimuth angles** text field, type 1440.
- 12 From the **Restriction** list, choose **Manual**.
- 13 In the  **$\theta$  start** text field, type 75.
- 14 In the  **$\theta$  range** text field, type 30.
- 15 Find the **Sphere** subsection. From the **Sphere** list, choose **Manual**.
- 16 In the **X** text field, type  $28[m]$ .
- 17 In the **Radius** text field, type  $100[m]$ .
- 18 In the **Radiation Pattern at 100 m** toolbar, click  **Plot**.

#### *Arrow Surface 1*

- 1 Right-click **Radiation Pattern at 100 m** and choose **Arrow Surface**.
- 2 In the **Settings** window for **Arrow Surface**, locate the **Expression** section.
- 3 In the **X-component** text field, type  $\cos(\phi)$ .
- 4 In the **Y-component** text field, type  $\sin(\phi)$ .
- 5 In the **Z-component** text field, type 0.
- 6 Click to expand the **Title** section. From the **Title type** list, choose **None**.
- 7 Locate the **Arrow Positioning** section. From the **Placement** list, choose **Uniform anisotropic**.
- 8 In the **Number of arrows** text field, type 1.
- 9 In the **X weight** text field, type 0.1.
- 10 Locate the **Coloring and Style** section. From the **Arrow base** list, choose **Head**.
- 11 Select the **Scale factor** checkbox. In the associated text field, type 50.



### Selection 1

- 1 Right-click **Arrow Surface 1** and choose **Selection**.
- 2 Select Boundary 36 only.
- 3 In the **Radiation Pattern at 100 m** toolbar, click  **Plot**.
- 4 Click the  **Zoom Extents** button in the **Graphics** toolbar.  
The plot should look like [Figure 3](#).

### Scattered Pressure at $z = 0$

- 1 In the **Results** toolbar, click  **2D Plot Group**.
- 2 In the **Settings** window for **2D Plot Group**, type Scattered Pressure at  $z = 0$  in the **Label** text field.
- 3 Locate the **Color Legend** section. Select the **Show units** checkbox.

### Surface 1

- 1 Right-click **Scattered Pressure at  $z = 0$**  and choose **Surface**.
- 2 In the **Settings** window for **Surface**, locate the **Data** section.
- 3 From the **Dataset** list, choose **Cut Plane 2**.
- 4 Locate the **Expression** section. In the **Expression** text field, type `pabe.p_s`.
- 5 Locate the **Coloring and Style** section. From the **Color table** list, choose **Wave**.
- 6 From the **Scale** list, choose **Linear symmetric**.
- 7 In the **Scattered Pressure at  $z = 0$**  toolbar, click  **Plot**.
- 8 Click the  **Zoom Extents** button in the **Graphics** toolbar.  
The plot should look like [Figure 4](#).

### Scattered Sound Pressure Level at $z = 0$

- 1 In the **Model Builder** window, right-click **Scattered Pressure at  $z = 0$**  and choose **Duplicate**.
- 2 In the **Model Builder** window, click **Scattered Pressure at  $z = 0.1$** .
- 3 In the **Settings** window for **2D Plot Group**, type Scattered Sound Pressure Level at  $z = 0$  in the **Label** text field.

### Surface 1

- 1 In the **Model Builder** window, click **Surface 1**.
- 2 In the **Settings** window for **Surface**, locate the **Expression** section.
- 3 In the **Expression** text field, type `pabe.Lp_s`.
- 4 Locate the **Coloring and Style** section. From the **Color table** list, choose **Rainbow**.

- 5 From the **Scale** list, choose **Linear**.
- 6 In the **Scattered Sound Pressure Level at  $z = 0$**  toolbar, click  **Plot**.  
The plot should look like [Figure 5](#).

*Radiation Pattern - Scattered Sound Pressure Level*

- 1 In the **Results** toolbar, click  **Polar Plot Group**.
- 2 In the **Settings** window for **Polar Plot Group**, type *Radiation Pattern - Scattered Sound Pressure Level* in the **Label** text field.
- 3 Locate the **Axis** section. From the **Zero angle** list, choose **Left**.

*Radiation Pattern 1*

- 1 In the **Radiation Pattern - Scattered Sound Pressure Level** toolbar, click  **More Plots** and choose **Radiation Pattern**.
- 2 In the **Settings** window for **Radiation Pattern**, locate the **Expression** section.
- 3 In the **Expression** text field, type `pabe.Lp_s`.
- 4 Locate the **Evaluation** section. Find the **Angles** subsection. In the **Number of angles** text field, type 5000.
- 5 Find the **Evaluation distance** subsection. In the **Radius** text field, type `d_source`.
- 6 Find the **Reference direction** subsection. In the **x** text field, type -1.
- 7 Click **Preview Evaluation Plane**.

- Click the  **Zoom Extents** button in the **Graphics** toolbar.  
The plot should look like this.

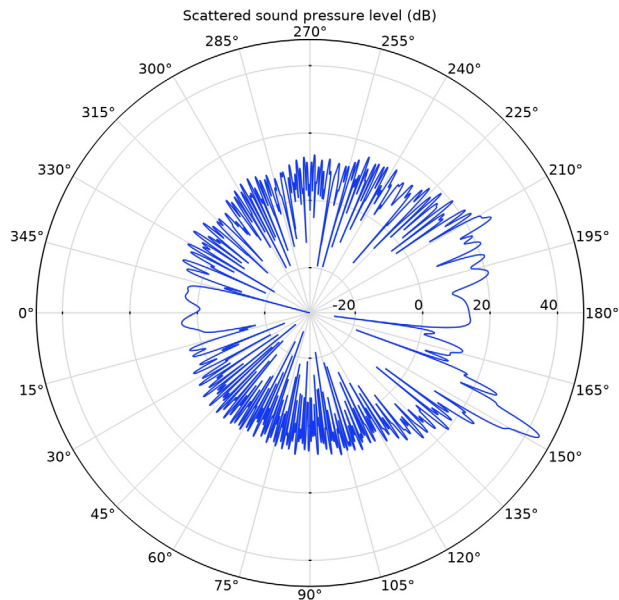

- In the **Radiation Pattern - Scattered Sound Pressure Level** toolbar, click  **Plot**.  
The plot should look like [Figure 6](#).

### *Bistatic Target Strength*

- In the **Results** toolbar, click  **ID Plot Group**.
- In the **Settings** window for **ID Plot Group**, type **Bistatic Target Strength** in the **Label** text field.
- Locate the **Data** section. From the **Dataset** list, choose **Parametric Curve 3D I**.

### *Line Graph 1*

- Right-click **Bistatic Target Strength** and choose **Line Graph**.
- In the **Settings** window for **Line Graph**, locate the **y-Axis Data** section.
- In the **Expression** text field, type **TS**.
- Locate the **x-Axis Data** section. From the **Parameter** list, choose **Expression**.
- In the **Expression** text field, type **s[rad]**.
- From the **Unit** list, choose **°**.

- 7 Select the **Description** checkbox. In the associated text field, type Receiver angle.
- 8 In the **Bistatic Target Strength** toolbar, click  **Plot**.  
The plot should look like [Figure 7](#).

## *Appendix — Geometry Modeling Instructions*



---

From the **File** menu, choose **New**.

### **NEW**

In the **New** window, click  **Model Wizard**.

### **MODEL WIZARD**

- 1 In the **Model Wizard** window, click  **3D**.
- 2 Click  **Done**.

### **GEOMETRY I**

- 1 In the **Model Builder** window, under **Component 1 (comp1)** click **Geometry 1**.
- 2 In the **Settings** window for **Geometry**, locate the **Advanced** section.
- 3 From the **Geometry representation** list, choose **CAD kernel**.

Disable the analysis of the geometry as the remaining small geometric details can be kept.

- 4 Locate the **Cleanup** section. Clear the **Automatic detection of small details** checkbox.

### **GLOBAL DEFINITIONS**

#### *Geometry Parameters*

- 1 In the **Model Builder** window, under **Global Definitions** click **Parameters 1**.
- 2 In the **Settings** window for **Parameters**, locate the **Parameters** section.
- 3 Click  **Load from File**.
- 4 Browse to the model's Application Libraries folder and double-click the file submarine\_target\_strength\_geom\_sequence\_parameters.txt.
- 5 In the **Label** text field, type Geometry Parameters.

## GEOMETRY I

*Work Plane 1 (wp1)*

In the **Geometry** toolbar, click  **Work Plane**.

*Work Plane 1 (wp1) > Plane Geometry*

In the **Model Builder** window, click **Plane Geometry**.

*Work Plane 1 (wp1) > Ellipse 1 (e1)*

1 In the **Work Plane** toolbar, click  **Ellipse**.

2 In the **Settings** window for **Ellipse**, locate the **Object Type** section.

3 From the **Type** list, choose **Curve**.

4 Locate the **Size and Shape** section. In the **a-semiaxis** text field, type b.

5 In the **b-semiaxis** text field, type a.

6 In the **Sector angle** text field, type 90.

7 Locate the **Position** section. In the **xw** text field, type a.

8 Locate the **Rotation Angle** section. In the **Rotation** text field, type 90.

9 Click  **Build Selected**.

*Work Plane 1 (wp1) > Line Segment 1 (ls1)*

1 In the **Work Plane** toolbar, click  **More Primitives** and choose **Line Segment**.

2 On the object **e1**, select Point 1 only.

3 In the **Settings** window for **Line Segment**, locate the **Endpoint** section.

4 From the **Specify** list, choose **Coordinates**.

5 In the **xw** text field, type a+L.

6 In the **yw** text field, type b.

7 Click  **Build Selected**.

8 Click the  **Zoom Extents** button in the **Graphics** toolbar.

*Work Plane 1 (wp1) > Circle 1 (c1)*

1 In the **Work Plane** toolbar, click  **Circle**.

2 In the **Settings** window for **Circle**, locate the **Object Type** section.

3 From the **Type** list, choose **Curve**.



4 Locate the **Size and Shape** section. In the **Radius** text field, type  $g2/\sin(\alpha)$ .

5 In the **Sector angle** text field, type  $\alpha$ .

6 Locate the **Position** section. In the **xw** text field, type a+L.

- 7 In the **yw** text field, type  $b - g2 / \sin(\alpha)$ .
- 8 Locate the **Rotation Angle** section. In the **Rotation** text field, type  $90 - \alpha$ .
- 9 Click  **Build Selected**.

*Work Plane 1 (wp1) > Line Segment 2 (ls2)*

- 1 In the **Work Plane** toolbar, click  **More Primitives** and choose **Line Segment**.
- 2 On the object **c1**, select Point 1 only.
- 3 In the **Settings** window for **Line Segment**, locate the **Endpoint** section.
- 4 From the **Specify** list, choose **Coordinates**.
- 5 In the **xw** text field, type  $a + L + g2 + g3$ .
- 6 In the **yw** text field, type  $(b - (1 - \cos(\alpha)) * g2 / \sin(\alpha)) - g3 * \tan(\alpha)$ .
- 7 Click  **Build Selected**.
- 8 Click the  **Zoom Extents** button in the **Graphics** toolbar.

*Work Plane 1 (wp1) > Delete Entities 1 (del1)*

- 1 Right-click **Plane Geometry** and choose **Delete Entities**.
- 2 On the object **c1**, select Boundaries 2 and 3 only.
- 3 On the object **e1**, select Boundaries 2 and 3 only.
- 4 In the **Work Plane** toolbar, click  **Build All**.

*Revolve 1 (rev1)*

- 1 In the **Model Builder** window, under **Component 1 (comp1) > Geometry 1** right-click **Work Plane 1 (wp1)** and choose **Revolve**.
- 2 In the **Settings** window for **Revolve**, locate the **Revolution Angles** section.
- 3 Click the **Angles** button.
- 4 In the **Start angle** text field, type  $60[\text{deg}]$ .
- 5 In the **End angle** text field, type  $180[\text{deg}]$ .
- 6 Locate the **Revolution Axis** section. Find the **Direction of revolution axis** subsection. In the **xw** text field, type 1.
- 7 In the **yw** text field, type 0.
- 8 Click  **Build Selected**.

*Work Plane 2 (wp2)*

- 1 In the **Geometry** toolbar, click  **Work Plane**.
- 2 In the **Settings** window for **Work Plane**, locate the **Plane Definition** section.

- 3 From the **Plane** list, choose **zy-plane**.
- 4 In the **x-coordinate** text field, type a.
- 5 Click  **Build Selected**.



*Work Plane 2 (wp2) > Plane Geometry*

In the **Model Builder** window, click **Plane Geometry**.

*Work Plane 2 (wp2) > Polygon 1 (pol1)*

- 1 In the **Work Plane** toolbar, click  **Polygon**.
- 2 In the **Settings** window for **Polygon**, locate the **Object Type** section.
- 3 From the **Type** list, choose **Open curve**.
- 4 Locate the **Coordinates** section. In the table, enter the following settings:

<b>xw (m)</b>	<b>yw (m)</b>
0	c_deck
s_deck	c_deck
$-\sin(\theta) \cdot b + s\_deck / 6 + s\_deck$	$c\_deck - (p\_a \cdot ((-\sin(\theta) \cdot b + s\_deck) / 6)^3 + p\_b \cdot ((-\sin(\theta) \cdot b + s\_deck) / 6)^2)$
$-\sin(\theta) \cdot b + s\_deck \cdot 2 / 6 + s\_deck$	$c\_deck - (p\_a \cdot ((-\sin(\theta) \cdot b + s\_deck) \cdot 2 / 6)^3 + p\_b \cdot ((-\sin(\theta) \cdot b + s\_deck) \cdot 2 / 6)^2)$
$-\sin(\theta) \cdot b + 1.2[m] \cdot 3 / 6 + s\_deck$	$c\_deck - (p\_a \cdot ((-\sin(\theta) \cdot b + s\_deck) \cdot 3 / 6)^3 + p\_b \cdot ((-\sin(\theta) \cdot b + s\_deck) \cdot 3 / 6)^2)$
$-\sin(\theta) \cdot b + 1.2[m] \cdot 4 / 6 + s\_deck$	$c\_deck - (p\_a \cdot ((-\sin(\theta) \cdot b + s\_deck) \cdot 4 / 6)^3 + p\_b \cdot ((-\sin(\theta) \cdot b + s\_deck) \cdot 4 / 6)^2)$
$-\sin(\theta) \cdot b + 1.2[m] \cdot 5 / 6 + s\_deck$	$c\_deck - (p\_a \cdot ((-\sin(\theta) \cdot b + s\_deck) \cdot 5 / 6)^3 + p\_b \cdot ((-\sin(\theta) \cdot b + s\_deck) \cdot 5 / 6)^2)$
$-\sin(\theta) \cdot b + 1.2[m] \cdot 6 / 6 + s\_deck$	$c\_deck - (p\_a \cdot ((-\sin(\theta) \cdot b + s\_deck) \cdot 6 / 6)^3 + p\_b \cdot ((-\sin(\theta) \cdot b + s\_deck) \cdot 6 / 6)^2)$

- 5 Click  **Build Selected**.
- 6 Click the  **Zoom Extents** button in the **Graphics** toolbar.

*Extrude 1 (ext1)*

- 1 In the **Model Builder** window, under **Component 1 (comp1) > Geometry 1** right-click **Work Plane 2 (wp2)** and choose **Extrude**.
- 2 In the **Settings** window for **Extrude**, locate the **Distances** section.

3 In the table, enter the following settings:

Distances (m)
L

4 Select the **Reverse direction** checkbox.

5 Click  **Build Selected**.

*Work Plane 3 (wp3)*

1 In the **Geometry** toolbar, click  **Work Plane**.

2 In the **Settings** window for **Work Plane**, locate the **Plane Definition** section.

3 From the **Plane type** list, choose **Coordinates**.

4 In row **Point 3**, set **y** to  $\cos(\text{theta})$ .

5 In row **Point 3**, set **z** to  $\sin(\text{theta})$ .

*Work Plane 3 (wp3) > Plane Geometry*

In the **Model Builder** window, click **Plane Geometry**.

*Work Plane 3 (wp3) > Line Segment 1 (ls1)*

1 In the **Work Plane** toolbar, click  **More Primitives** and choose **Line Segment**.

2 In the **Settings** window for **Line Segment**, locate the **Starting Point** section.

3 From the **Specify** list, choose **Coordinates**.

4 In the **xw** text field, type  $a+L+g2$ .

5 In the **yw** text field, type  $(b - (1 - \cos(\alpha)) * g2 / \sin(\alpha))$ .

6 Locate the **Endpoint** section. From the **Specify** list, choose **Coordinates**.

7 In the **xw** text field, type  $a+L+g2+g3$ .

8 In the **yw** text field, type  $(b - (1 - \cos(\alpha)) * g2 / \sin(\alpha)) - g3 * \tan(\alpha)$ .

9 Click  **Build Selected**.

*Revolve 2 (rev2)*

1 In the **Model Builder** window, under **Component 1 (comp1) > Geometry 1** right-click **Work Plane 3 (wp3)** and choose **Revolve**.

2 In the **Settings** window for **Revolve**, locate the **Revolution Angles** section.

3 Click the **Angles** button.

4 In the **End angle** text field, type  $-60$ .

5 Locate the **Revolution Axis** section. Find the **Direction of revolution axis** subsection. In the **xw** text field, type  $1$ .

6 In the **yw** text field, type 0.

7 Click  **Build Selected**.

#### Work Plane 4 (wp4)

1 In the **Geometry** toolbar, click  **Work Plane**.

2 In the **Settings** window for **Work Plane**, locate the **Plane Definition** section.

3 From the **Plane type** list, choose **Coordinates**.

4 In row **Point 3**, set **x** to 7.

5 In row **Point 3**, set **y** to c\_deck.

6 In row **Point 3**, set **z** to s\_deck.

7 Click  **Build Selected**.

#### Work Plane 4 (wp4) > Plane Geometry

In the **Model Builder** window, click **Plane Geometry**.

#### Work Plane 4 (wp4) > Ellipse 1 (e1)

1 In the **Work Plane** toolbar, click  **Ellipse**.

2 In the **Settings** window for **Ellipse**, locate the **Object Type** section.

3 From the **Type** list, choose **Curve**.

4 Locate the **Size and Shape** section. In the **a-semiaxis** text field, type a.

5 In the **b-semiaxis** text field, type  $\sqrt{c\_deck^2+s\_deck^2}$ .

6 In the **Sector angle** text field, type 180.

7 Locate the **Position** section. In the **xw** text field, type a.

8 Click  **Build Selected**.

#### Work Plane 4 (wp4) > Interpolation Curve 1 (ic1)

1 In the **Work Plane** toolbar, click  **More Primitives** and choose **Interpolation Curve**.



2 In the **Settings** window for **Interpolation Curve**, locate the **Interpolation Points** section.

3 In the table, enter the following settings:



<b>xw (m)</b>	<b>yw (m)</b>
a+L-0.1[m]	$\sqrt{c\_deck^2+s\_deck^2}$
a+L	$\sqrt{c\_deck^2+s\_deck^2}$
a+L+g2	$(b - (1 - \cos(\alpha)) * g2 / \sin(\alpha))$
a+L+g2+0.1[m]	$(b - (1 - \cos(\alpha)) * g2 / \sin(\alpha)) - 0.1[m] * \tan(\alpha)$

4 Click  **Build Selected**.



*Work Plane 4 (wp4) > Line Segment 1 (ls1)*

- 1 In the **Work Plane** toolbar, click  **More Primitives** and choose **Line Segment**.
- 2 In the **Settings** window for **Line Segment**, locate the **Starting Point** section.
- 3 From the **Specify** list, choose **Coordinates**.
- 4 In the **xw** text field, type a+L.
- 5 Locate the **Endpoint** section. From the **Specify** list, choose **Coordinates**.
- 6 In the **xw** text field, type a+L.
- 7 In the **yw** text field, type c\_deck+s\_deck.
- 8 Click  **Build Selected**.

*Work Plane 4 (wp4) > Line Segment 2 (ls2)*

- 1 In the **Work Plane** toolbar, click  **More Primitives** and choose **Line Segment**.
- 2 In the **Settings** window for **Line Segment**, locate the **Starting Point** section.
- 3 From the **Specify** list, choose **Coordinates**.
- 4 In the **xw** text field, type a+L+g2.
- 5 Locate the **Endpoint** section. From the **Specify** list, choose **Coordinates**.
- 6 In the **xw** text field, type a+L+g2.
- 7 In the **yw** text field, type c\_deck+s\_deck.
- 8 Click  **Build Selected**.

*Work Plane 4 (wp4) > Union 1 (uni1)*

- 1 In the **Work Plane** toolbar, click  **Booleans and Partitions** and choose **Union**.
- 2 Click the  **Select All** button in the **Graphics** toolbar.
- 3 In the **Settings** window for **Union**, click  **Build Selected**.



*Work Plane 4 (wp4) > Delete Entities 1 (del1)*

- 1 Right-click **Plane Geometry** and choose **Delete Entities**.
- 2 On the object **uni1**, select Boundaries 1–6, 8, 9, and 11 only.
- 3 In the **Settings** window for **Delete Entities**, click  **Build Selected**.

*Work Plane 4 (wp4)*

- 1 In the **Model Builder** window, under **Component 1 (comp1) > Geometry 1** click **Work Plane 4 (wp4)**.
- 2 In the **Settings** window for **Work Plane**, click  **Build Selected**.



Work Plane 5 (wp5)

- 1 In the **Geometry** toolbar, click  **Work Plane**.
- 2 In the **Settings** window for **Work Plane**, locate the **Plane Definition** section.
- 3 From the **Plane type** list, choose **Coordinates**.
- 4 In row **Point 3**, set **x** to 7.
- 5 In row **Point 3**, set **y** to  $c\_deck - (p\_a * ((-\sin(\theta) * b + s\_deck) / 6)^3 + p\_b * ((-\sin(\theta) * b + s\_deck) / 6)^2)$ .
- 6 In row **Point 3**, set **z** to  $-(-\sin(\theta) * b + s\_deck) / 6 + s\_deck$ .
- 7 Click  **Build Selected**.

Work Plane 5 (wp5) > Plane Geometry

In the **Model Builder** window, click **Plane Geometry**.

Work Plane 5 (wp5) > Ellipse 1 (e1)

- 1 In the **Work Plane** toolbar, click  **Ellipse**.
- 2 In the **Settings** window for **Ellipse**, locate the **Object Type** section.
- 3 From the **Type** list, choose **Curve**.
- 4 Locate the **Size and Shape** section. In the **a-semiaxis** text field, type **a**.
- 5 In the **b-semiaxis** text field, type  $\sqrt{(c\_deck - (p\_a * ((-\sin(\theta) * b + s\_deck) / 6)^3 + p\_b * ((-\sin(\theta) * b + s\_deck) / 6)^2))^2 + (-(-\sin(\theta) * b + s\_deck) / 6 + s\_deck)^2}$ .
- 6 In the **Sector angle** text field, type 180.
- 7 Locate the **Position** section. In the **xw** text field, type **a**.
- 8 Click  **Build Selected**.

Work Plane 5 (wp5) > Interpolation Curve 1 (ic1)

- 1 In the **Work Plane** toolbar, click  **More Primitives** and choose **Interpolation Curve**.
- 2 In the **Settings** window for **Interpolation Curve**, locate the **Interpolation Points** section.
- 3 In the table, enter the following settings:

xw (m)	yw (m)
a+L- 0.1[m ]	$\sqrt{(c\_deck - (p\_a * ((-\sin(\theta) * b + s\_deck) / 6)^3 + p\_b * ((-\sin(\theta) * b + s\_deck) / 6)^2))^2 + (-(-\sin(\theta) * b + s\_deck) / 6 + s\_deck)^2}$
a+L	$\sqrt{(c\_deck - (p\_a * ((-\sin(\theta) * b + s\_deck) / 6)^3 + p\_b * ((-\sin(\theta) * b + s\_deck) / 6)^2))^2 + (-(-\sin(\theta) * b + s\_deck) / 6 + s\_deck)^2}$

<b>xw (m)</b>	<b>yw (m)</b>
a+L+ g2	$(b - (1 - \cos(\alpha)) * g2 / \sin(\alpha))$
a+L+ g2+ 0.1[m ]	$(b - (1 - \cos(\alpha)) * g2 / \sin(\alpha)) - 0.1[m] * \tan(\alpha)$

4 Click  **Build Selected.**

*Work Plane 5 (wp5) > Line Segment 1 (ls1)*

1 In the **Work Plane** toolbar, click  **More Primitives** and choose **Line Segment**.

2 In the **Settings** window for **Line Segment**, locate the **Starting Point** section.

3 From the **Specify** list, choose **Coordinates**.

4 In the **xw** text field, type a+L.

5 Locate the **Endpoint** section. From the **Specify** list, choose **Coordinates**.

6 In the **xw** text field, type a+L.

7 In the **yw** text field, type c\_deck+s\_deck.

8 Click  **Build Selected.**

*Work Plane 5 (wp5) > Line Segment 2 (ls2)*

1 In the **Work Plane** toolbar, click  **More Primitives** and choose **Line Segment**.

2 In the **Settings** window for **Line Segment**, locate the **Starting Point** section.

3 From the **Specify** list, choose **Coordinates**.

4 In the **xw** text field, type a+L+g2.

5 Locate the **Endpoint** section. From the **Specify** list, choose **Coordinates**.

6 In the **xw** text field, type a+L+g2.

7 In the **yw** text field, type c\_deck+s\_deck.

8 Click  **Build Selected.**

*Work Plane 5 (wp5) > Union 1 (uni1)*

1 In the **Work Plane** toolbar, click  **Booleans and Partitions** and choose **Union**.

2 Click the  **Select All** button in the **Graphics** toolbar.

3 In the **Settings** window for **Union**, click  **Build Selected.**

*Work Plane 5 (wp5) > Delete Entities 1 (del1)*



1 Right-click **Plane Geometry** and choose **Delete Entities**.

- 2 On the object **uni1**, select Boundaries 1–6, 8, 9, and 11 only.
- 3 In the **Settings** window for **Delete Entities**, click  **Build Selected**.

*Work Plane 5 (wp5)*

- 1 In the **Model Builder** window, under **Component 1 (comp1) > Geometry 1** click **Work Plane 5 (wp5)**.
- 2 In the **Settings** window for **Work Plane**, click  **Build Selected**.



*Work Plane 6 (wp6)*

- 1 In the **Geometry** toolbar, click  **Work Plane**.
- 2 In the **Settings** window for **Work Plane**, locate the **Plane Definition** section.
- 3 From the **Plane type** list, choose **Coordinates**.
- 4 In row **Point 3**, set **x** to 7.
- 5 In row **Point 3**, set **y** to  $c\_deck - (p\_a * ((-\sin(\theta) * b + s\_deck) * 2/6)^2 + p\_b * ((-\sin(\theta) * b + s\_deck) * 2/6)^2)$ .
- 6 In row **Point 3**, set **z** to  $-(-\sin(\theta) * b + s\_deck) * 2/6 + s\_deck$ .
- 7 Click  **Build Selected**.

*Work Plane 6 (wp6) > Plane Geometry*

In the **Model Builder** window, click **Plane Geometry**.

*Work Plane 6 (wp6) > Ellipse 1 (e1)*

- 1 In the **Work Plane** toolbar, click  **Ellipse**.
- 2 In the **Settings** window for **Ellipse**, locate the **Object Type** section.
- 3 From the **Type** list, choose **Curve**.
- 4 Locate the **Size and Shape** section. In the **a-semiaxis** text field, type **a**.
- 5 In the **b-semiaxis** text field, type  $\sqrt{(c\_deck - (p\_a * ((-\sin(\theta) * b + s\_deck) * 2/6)^2 + p\_b * ((-\sin(\theta) * b + s\_deck) * 2/6)^2))^2 + (-(-\sin(\theta) * b + s\_deck) * 2/6 + s\_deck)^2}$ .
- 6 In the **Sector angle** text field, type 180.
- 7 Locate the **Position** section. In the **xw** text field, type **a**.
- 8 Click  **Build Selected**.

*Work Plane 6 (wp6) > Interpolation Curve 1 (ic1)*

- 1 In the **Work Plane** toolbar, click  **More Primitives** and choose **Interpolation Curve**.
- 2 In the **Settings** window for **Interpolation Curve**, locate the **Interpolation Points** section.

3 In the table, enter the following settings:

<b>xw (m)</b>	<b>yw (m)</b>
a+L- 0.1[m ]	$\sqrt{(c\_deck - (p\_a * ((-\sin(\theta) * b + s\_deck) * 2/6)^3 + p\_b * ((-\sin(\theta) * b + s\_deck) * 2/6)^2))^2 + (-(-\sin(\theta) * b + s\_deck) * 2/6 + s\_deck)^2}$
a+L	$\sqrt{(c\_deck - (p\_a * ((-\sin(\theta) * b + s\_deck) * 2/6)^3 + p\_b * ((-\sin(\theta) * b + s\_deck) * 2/6)^2))^2 + (-(-\sin(\theta) * b + s\_deck) * 2/6 + s\_deck)^2}$
a+L+ g2	$(b - (1 - \cos(\alpha)) * g2 / \sin(\alpha))$
a+L+ g2+ 0.1[m ]	$(b - (1 - \cos(\alpha)) * g2 / \sin(\alpha)) - 0.1[m] * \tan(\alpha)$

4 Click  **Build Selected.**

*Work Plane 6 (wp6) > Line Segment 1 (ls1)*

1 In the **Work Plane** toolbar, click  **More Primitives** and choose **Line Segment**.

2 In the **Settings** window for **Line Segment**, locate the **Starting Point** section.

3 From the **Specify** list, choose **Coordinates**.

4 In the **xw** text field, type a+L.

5 Locate the **Endpoint** section. From the **Specify** list, choose **Coordinates**.

6 In the **xw** text field, type a+L.

7 In the **yw** text field, type c\_deck+s\_deck.

8 Click  **Build Selected.**

*Work Plane 6 (wp6) > Line Segment 2 (ls2)*

1 In the **Work Plane** toolbar, click  **More Primitives** and choose **Line Segment**.

2 In the **Settings** window for **Line Segment**, locate the **Starting Point** section.

3 From the **Specify** list, choose **Coordinates**.

4 In the **xw** text field, type a+L+g2.



5 Locate the **Endpoint** section. From the **Specify** list, choose **Coordinates**.

6 In the **xw** text field, type a+L+g2.

7 In the **yw** text field, type c\_deck+s\_deck.

8 Click  **Build Selected.**

*Work Plane 6 (wp6) > Union 1 (uni1)*

- 1 In the **Work Plane** toolbar, click  **Booleans and Partitions** and choose **Union**.
- 2 Click the  **Select All** button in the **Graphics** toolbar.
- 3 In the **Settings** window for **Union**, click  **Build Selected**.



*Work Plane 6 (wp6) > Delete Entities 1 (del1)*

- 1 Right-click **Plane Geometry** and choose **Delete Entities**.
- 2 On the object **uni1**, select Boundaries 1–6, 8, 9, and 11 only.
- 3 In the **Settings** window for **Delete Entities**, click  **Build Selected**.

*Work Plane 6 (wp6)*

- 1 In the **Model Builder** window, under **Component 1 (comp1) > Geometry 1** click **Work Plane 6 (wp6)**.
- 2 In the **Settings** window for **Work Plane**, click  **Build Selected**.

*Work Plane 7 (wp7)*

- 1 In the **Geometry** toolbar, click  **Work Plane**.
- 2 In the **Settings** window for **Work Plane**, locate the **Plane Definition** section.
- 3 From the **Plane type** list, choose **Coordinates**.
- 4 In row **Point 3**, set **x** to 7.
- 5 In row **Point 3**, set **y** to  $c\_deck - (p\_a * ((-\sin(\theta) * b + s\_deck) * 3/6)^3 + p\_b * ((-\sin(\theta) * b + s\_deck) * 3/6)^2)$ .
- 6 In row **Point 3**, set **z** to  $-(-\sin(\theta) * b + s\_deck) * 3/6 + s\_deck$ .
- 7 Click  **Build Selected**.

*Work Plane 7 (wp7) > Plane Geometry*

In the **Model Builder** window, click **Plane Geometry**.

*Work Plane 7 (wp7) > Ellipse 1 (e1)*

- 1 In the **Work Plane** toolbar, click  **Ellipse**.
- 2 In the **Settings** window for **Ellipse**, locate the **Object Type** section.
- 3 From the **Type** list, choose **Curve**.
- 4 Locate the **Size and Shape** section. In the **a-semiaxis** text field, type **a**.
- 5 In the **b-semiaxis** text field, type  $\sqrt{(c\_deck - (p\_a * ((-\sin(\theta) * b + s\_deck) * 3/6)^3 + p\_b * ((-\sin(\theta) * b + s\_deck) * 3/6)^2))^2 + (-(-\sin(\theta) * b + s\_deck) * 3/6 + s\_deck)^2}$ .
- 6 In the **Sector angle** text field, type 180.

7 Locate the **Position** section. In the **xw** text field, type a.

8 Click  **Build Selected**.

*Work Plane 7 (wp7) > Interpolation Curve 1 (ic1)*

- 1 In the **Work Plane** toolbar, click  **More Primitives** and choose **Interpolation Curve**.
- 2 In the **Settings** window for **Interpolation Curve**, locate the **Interpolation Points** section.
- 3 In the table, enter the following settings:

<b>xw (m)</b>	<b>yw (m)</b>
a+L- 0.1[m ]	$\sqrt{((c\_deck - (p\_a * ((-\sin(\theta) * b + s\_deck) * 3/6)^3 + p\_b * ((-\sin(\theta) * b + s\_deck) * 3/6)^2))^2 + (-(-\sin(\theta) * b + s\_deck) * 3/6 + s\_deck)^2)}$
a+L	$\sqrt{((c\_deck - (p\_a * ((-\sin(\theta) * b + s\_deck) * 3/6)^3 + p\_b * ((-\sin(\theta) * b + s\_deck) * 3/6)^2))^2 + (-(-\sin(\theta) * b + s\_deck) * 3/6 + s\_deck)^2)}$
a+L+ g2	$(b - (1 - \cos(\alpha)) * g2 / \sin(\alpha))$
a+L+ g2+ 0.1[m ]	$(b - (1 - \cos(\alpha)) * g2 / \sin(\alpha)) - 0.1[m] * \tan(\alpha)$

4 Click  **Build Selected**.

*Work Plane 7 (wp7) > Line Segment 1 (ls1)*

- 1 In the **Work Plane** toolbar, click  **More Primitives** and choose **Line Segment**.
- 2 In the **Settings** window for **Line Segment**, locate the **Starting Point** section.
- 3 From the **Specify** list, choose **Coordinates**.
- 4 In the **xw** text field, type a+L.
- 5 Locate the **Endpoint** section. From the **Specify** list, choose **Coordinates**.
- 6 In the **xw** text field, type a+L.
- 7 In the **yw** text field, type c\_deck+s\_deck.

8 Click  **Build Selected**.

*Work Plane 7 (wp7) > Line Segment 2 (ls2)*

- 1 In the **Work Plane** toolbar, click  **More Primitives** and choose **Line Segment**.
- 2 In the **Settings** window for **Line Segment**, locate the **Starting Point** section.
- 3 From the **Specify** list, choose **Coordinates**.
- 4 In the **xw** text field, type a+L+g2.

5 Locate the **Endpoint** section. From the **Specify** list, choose **Coordinates**.

6 In the **xw** text field, type **a+L+g2**.

7 In the **yw** text field, type **c\_deck+s\_deck**.

8 Click  **Build Selected**.

*Work Plane 7 (wp7) > Union 1 (uni)*

1 In the **Work Plane** toolbar, click  **Booleans and Partitions** and choose **Union**.

2 Click the  **Select All** button in the **Graphics** toolbar.

3 In the **Settings** window for **Union**, click  **Build Selected**.

*Work Plane 7 (wp7) > Delete Entities 1 (del1)*

1 Right-click **Plane Geometry** and choose **Delete Entities**.

2 On the object **uni1**, select Boundaries 1–6, 8, 9, and 11 only.

3 In the **Settings** window for **Delete Entities**, click  **Build Selected**.

*Work Plane 7 (wp7)*

1 In the **Model Builder** window, under **Component 1 (comp1) > Geometry 1** click **Work Plane 7 (wp7)**.

2 In the **Settings** window for **Work Plane**, click  **Build Selected**.

*Work Plane 8 (wp8)*

1 In the **Geometry** toolbar, click  **Work Plane**.

2 In the **Settings** window for **Work Plane**, locate the **Plane Definition** section.

3 From the **Plane type** list, choose **Coordinates**.

4 In row **Point 3**, set **x** to 7.

5 In row **Point 3**, set **y** to  $c\_deck - (p\_a * ((-\sin(\theta) * b + s\_deck) * 4/6)^3 + p\_b * ((-\sin(\theta) * b + s\_deck) * 4/6)^2)$ .

6 In row **Point 3**, set **z** to  $-( -\sin(\theta) * b + s\_deck) * 4/6 + s\_deck$ .

7 Click  **Build Selected**.

*Work Plane 8 (wp8) > Plane Geometry*

In the **Model Builder** window, click **Plane Geometry**.

*Work Plane 8 (wp8) > Ellipse 1 (e1)*

1 In the **Work Plane** toolbar, click  **Ellipse**.

2 In the **Settings** window for **Ellipse**, locate the **Object Type** section.

3 From the **Type** list, choose **Curve**.

- 4 Locate the **Size and Shape** section. In the **a-semiaxis** text field, type a.
- 5 In the **b-semiaxis** text field, type  $\sqrt{(c\_deck - (p\_a * ((-\sin(\theta) * b + s\_deck) * 4/6)^3 + p\_b * ((-\sin(\theta) * b + s\_deck) * 4/6)^2))^2 + (-(\sin(\theta) * b + s\_deck) * 4/6 + s\_deck)^2}$ .
- 6 In the **Sector angle** text field, type 180.
- 7 Locate the **Position** section. In the **xw** text field, type a.
- 8 Click  **Build Selected**.



*Work Plane 8 (wp8) > Interpolation Curve 1 (ic1)*

- 1 In the **Work Plane** toolbar, click  **More Primitives** and choose **Interpolation Curve**.
- 2 In the **Settings** window for **Interpolation Curve**, locate the **Interpolation Points** section.
- 3 In the table, enter the following settings:



<b>xw (m)</b>	<b>yw (m)</b>
a+L- 0.1[m ]	$\sqrt{(c\_deck - (p\_a * ((-\sin(\theta) * b + s\_deck) * 4/6)^3 + p\_b * ((-\sin(\theta) * b + s\_deck) * 4/6)^2))^2 + (-(\sin(\theta) * b + s\_deck) * 4/6 + s\_deck)^2}$
a+L	$\sqrt{(c\_deck - (p\_a * ((-\sin(\theta) * b + s\_deck) * 4/6)^3 + p\_b * ((-\sin(\theta) * b + s\_deck) * 4/6)^2))^2 + (-(\sin(\theta) * b + s\_deck) * 4/6 + s\_deck)^2}$
a+L+ g2	$(b - (1 - \cos(\alpha)) * g2 / \sin(\alpha))$
a+L+ g2+ 0.1[m ]	$(b - (1 - \cos(\alpha)) * g2 / \sin(\alpha)) - 0.1[m] * \tan(\alpha)$

- 4 Click  **Build Selected**.



*Work Plane 8 (wp8) > Line Segment 1 (ls1)*

- 1 In the **Work Plane** toolbar, click  **More Primitives** and choose **Line Segment**.
- 2 In the **Settings** window for **Line Segment**, locate the **Starting Point** section.
- 3 From the **Specify** list, choose **Coordinates**.
- 4 In the **xw** text field, type a+L.
- 5 Locate the **Endpoint** section. From the **Specify** list, choose **Coordinates**.
- 6 In the **xw** text field, type a+L.
- 7 In the **yw** text field, type c\_deck+s\_deck.
- 8 Click  **Build Selected**.

*Work Plane 8 (wp8) > Line Segment 2 (ls2)*

- 1 In the **Work Plane** toolbar, click  **More Primitives** and choose **Line Segment**.
- 2 In the **Settings** window for **Line Segment**, locate the **Starting Point** section.
- 3 From the **Specify** list, choose **Coordinates**.
- 4 In the **xw** text field, type a+L+g2.
- 5 Locate the **Endpoint** section. From the **Specify** list, choose **Coordinates**.
- 6 In the **xw** text field, type a+L+g2.
- 7 In the **yw** text field, type c\_deck+s\_deck.
- 8 Click  **Build Selected**.

*Work Plane 8 (wp8) > Union 1 (uni1)*

- 1 In the **Work Plane** toolbar, click  **Booleans and Partitions** and choose **Union**.
- 2 Click the  **Select All** button in the **Graphics** toolbar.
- 3 In the **Settings** window for **Union**, click  **Build Selected**.



*Work Plane 8 (wp8) > Delete Entities 1 (dell)*

- 1 Right-click **Plane Geometry** and choose **Delete Entities**.
- 2 On the object **uni1**, select Boundaries 1–6, 8, 9, and 11 only.
- 3 In the **Settings** window for **Delete Entities**, click  **Build Selected**.

*Work Plane 8 (wp8)*

- 1 In the **Model Builder** window, under **Component 1 (comp1) > Geometry 1** click **Work Plane 8 (wp8)**.
- 2 In the **Settings** window for **Work Plane**, click  **Build Selected**.



*Work Plane 9 (wp9)*

- 1 In the **Geometry** toolbar, click  **Work Plane**.
- 2 In the **Settings** window for **Work Plane**, locate the **Plane Definition** section.
- 3 From the **Plane type** list, choose **Coordinates**.
- 4 In row **Point 3**, set **x** to 7.
- 5 In row **Point 3**, set **y** to  $c\_deck - (p\_a * ((-\sin(\theta) * b + s\_deck) * 5/6)^3 + p\_b * ((-\sin(\theta) * b + s\_deck) * 5/6)^2)$ .
- 6 In row **Point 3**, set **z** to  $-(-\sin(\theta) * b + s\_deck) * 5/6 + s\_deck$ .
- 7 Click  **Build Selected**.

Work Plane 9 (wp9) > Plane Geometry

In the **Model Builder** window, click **Plane Geometry**.

Work Plane 9 (wp9) > Ellipse 1 (e1)

- 1 In the **Work Plane** toolbar, click  **Ellipse**.
- 2 In the **Settings** window for **Ellipse**, locate the **Object Type** section.
- 3 From the **Type** list, choose **Curve**.
- 4 Locate the **Size and Shape** section. In the **a-semiaxis** text field, type a.
- 5 In the **b-semiaxis** text field, type  $\sqrt{(c\_deck - (p\_a * ((-\sin(\theta) * b + s\_deck) * 5/6)^3 + p\_b * ((-\sin(\theta) * b + s\_deck) * 5/6)^2))^2 + (-(\sin(\theta) * b + s\_deck) * 5/6 + s\_deck)^2)}$ .
- 6 In the **Sector angle** text field, type 180.
- 7 Locate the **Position** section. In the **xw** text field, type a.
- 8 Click  **Build Selected**.

Work Plane 9 (wp9) > Interpolation Curve 1 (ic1)

- 1 In the **Work Plane** toolbar, click  **More Primitives** and choose **Interpolation Curve**.
- 2 In the **Settings** window for **Interpolation Curve**, locate the **Interpolation Points** section.
- 3 In the table, enter the following settings:

xw (m)	yw (m)
a+L- 0.1[m ]	$\sqrt{(c\_deck - (p\_a * ((-\sin(\theta) * b + s\_deck) * 5/6)^3 + p\_b * ((-\sin(\theta) * b + s\_deck) * 5/6)^2))^2 + (-(\sin(\theta) * b + s\_deck) * 5/6 + s\_deck)^2)}$
a+L	$\sqrt{(c\_deck - (p\_a * ((-\sin(\theta) * b + s\_deck) * 5/6)^3 + p\_b * ((-\sin(\theta) * b + s\_deck) * 5/6)^2))^2 + (-(\sin(\theta) * b + s\_deck) * 5/6 + s\_deck)^2)}$
a+L+ g2	$(b - (1 - \cos(\alpha)) * g2 / \sin(\alpha))$
a+L+ g2+ 0.1[m ]	$(b - (1 - \cos(\alpha)) * g2 / \sin(\alpha)) - 0.1[m] * \tan(\alpha)$



- 4 Click  **Build Selected**.

Work Plane 9 (wp9) > Line Segment 1 (ls1)



- 1 In the **Work Plane** toolbar, click  **More Primitives** and choose **Line Segment**.
- 2 In the **Settings** window for **Line Segment**, locate the **Starting Point** section.

- 3 From the **Specify** list, choose **Coordinates**.
- 4 In the **xw** text field, type a+L.
- 5 Locate the **Endpoint** section. From the **Specify** list, choose **Coordinates**.
- 6 In the **xw** text field, type a+L.
- 7 In the **yw** text field, type c\_deck+s\_deck.
- 8 Click  **Build Selected**.

*Work Plane 9 (wp9) > Line Segment 2 (ls2)*

- 1 In the **Work Plane** toolbar, click  **More Primitives** and choose **Line Segment**.
- 2 In the **Settings** window for **Line Segment**, locate the **Starting Point** section.
- 3 From the **Specify** list, choose **Coordinates**.
- 4 In the **xw** text field, type a+L+g2.
- 5 Locate the **Endpoint** section. From the **Specify** list, choose **Coordinates**.
- 6 In the **xw** text field, type a+L+g2.
- 7 In the **yw** text field, type c\_deck+s\_deck.
- 8 Click  **Build Selected**.

*Work Plane 9 (wp9) > Union 1 (uni1)*

- 1 In the **Work Plane** toolbar, click  **Booleans and Partitions** and choose **Union**.
- 2 Click the  **Select All** button in the **Graphics** toolbar.
- 3 In the **Settings** window for **Union**, click  **Build Selected**.

*Work Plane 9 (wp9) > Delete Entities 1 (dell)*

- 1 Right-click **Plane Geometry** and choose **Delete Entities**.
- 2 On the object **uni1**, select Boundaries 1–6, 8, 9, and 11 only.
- 3 In the **Settings** window for **Delete Entities**, click  **Build Selected**.

*Work Plane 9 (wp9)*

- 1 In the **Model Builder** window, under **Component 1 (comp1) > Geometry 1** click **Work Plane 9 (wp9)**.
- 2 In the **Settings** window for **Work Plane**, click  **Build Selected**.



*Work Plane 10 (wp10)*

In the **Geometry** toolbar, click  **Work Plane**.

*Work Plane 10 (wp10) > Plane Geometry*

In the **Model Builder** window, click **Plane Geometry**.

Work Plane 10 (wp10) > Ellipse 1 (e1)

- 1 In the **Work Plane** toolbar, click  **Ellipse**.
- 2 In the **Settings** window for **Ellipse**, locate the **Object Type** section.
- 3 From the **Type** list, choose **Curve**.
- 4 Locate the **Size and Shape** section. In the **a-semiaxis** text field, type a.
- 5 In the **b-semiaxis** text field, type c\_deck.
- 6 In the **Sector angle** text field, type 180.
- 7 Locate the **Position** section. In the **xw** text field, type a.
- 8 Click  **Build Selected**.



Work Plane 10 (wp10) > Interpolation Curve 1 (ic1)

- 1 In the **Work Plane** toolbar, click  **More Primitives** and choose **Interpolation Curve**.
- 2 In the **Settings** window for **Interpolation Curve**, locate the **Interpolation Points** section.
- 3 In the table, enter the following settings:

<b>xw (m)</b>	<b>yw (m)</b>
a+L-0.1[m]	c_deck
a+L	c_deck
a+L+g2	$(b - (1 - \cos(\alpha)) * g2 / \sin(\alpha))$
a+L+g2+0.1[m]	$(b - (1 - \cos(\alpha)) * g2 / \sin(\alpha)) - 0.1[m] * \tan(\alpha)$

- 4 Click  **Build Selected**.

Work Plane 10 (wp10) > Line Segment 1 (ls1)



- 1 In the **Work Plane** toolbar, click  **More Primitives** and choose **Line Segment**.
- 2 In the **Settings** window for **Line Segment**, locate the **Starting Point** section.
- 3 From the **Specify** list, choose **Coordinates**.
- 4 In the **xw** text field, type a+L.
- 5 Locate the **Endpoint** section. From the **Specify** list, choose **Coordinates**.
- 6 In the **xw** text field, type a+L.
- 7 In the **yw** text field, type c\_deck+s\_deck.
- 8 Click  **Build Selected**.

Work Plane 10 (wp10) > Line Segment 2 (ls2)

- 1 In the **Work Plane** toolbar, click  **More Primitives** and choose **Line Segment**.
- 2 In the **Settings** window for **Line Segment**, locate the **Starting Point** section.

- 3 From the **Specify** list, choose **Coordinates**.
- 4 In the **xw** text field, type a+L+g2.
- 5 Locate the **Endpoint** section. From the **Specify** list, choose **Coordinates**.
- 6 In the **xw** text field, type a+L+g2.
- 7 In the **yw** text field, type c\_deck+s\_deck.
- 8 Click  **Build Selected**.

*Work Plane 10 (wp10) > Union 1 (uni1)*

- 1 In the **Work Plane** toolbar, click  **Booleans and Partitions** and choose **Union**.
- 2 Click the  **Select All** button in the **Graphics** toolbar.
- 3 In the **Settings** window for **Union**, click  **Build Selected**.



*Work Plane 10 (wp10) > Delete Entities 1 (dell)*

- 1 Right-click **Plane Geometry** and choose **Delete Entities**.
- 2 On the object **uni1**, select Boundaries 1–6, 8, 9, and 11 only.
- 3 In the **Settings** window for **Delete Entities**, click  **Build Selected**.

*Work Plane 10 (wp10)*

- 1 In the **Model Builder** window, under **Component 1 (comp1) > Geometry 1** click **Work Plane 10 (wp10)**.
- 2 In the **Settings** window for **Work Plane**, click  **Build Selected**.

*Union 1 (uni1)*

- 1 In the **Geometry** toolbar, click  **Booleans and Partitions** and choose **Union**.
- 2 Click the  **Select All** button in the **Graphics** toolbar.
- 3 In the **Settings** window for **Union**, click  **Build Selected**.

*Cap Faces 1 (cap1)*

- 1 In the **Geometry** toolbar, click  **Defeaturing and Repair** and choose **Cap Faces**.
- 2 On the object **uni1**, select Edges 46–48 and 60 only.
- 3 In the **Settings** window for **Cap Faces**, click  **Build Selected**.



*Cap Faces 2 (cap2)*

- 1 In the **Geometry** toolbar, click  **Defeaturing and Repair** and choose **Cap Faces**.
- 2 On the object **cap1**, select Edges 44, 45, 48, and 59 only.
- 3 In the **Settings** window for **Cap Faces**, click  **Build Selected**.

#### Cap Faces 3 (cap3)

- 1 In the **Geometry** toolbar, click  **Defeaturing and Repair** and choose **Cap Faces**.
- 2 On the object **cap2**, select Edges 42, 43, 45, and 58 only.
- 3 In the **Settings** window for **Cap Faces**, click  **Build Selected**.



#### Cap Faces 4 (cap4)

- 1 In the **Geometry** toolbar, click  **Defeaturing and Repair** and choose **Cap Faces**.
- 2 On the object **cap3**, select Edges 40, 41, 43, and 57 only.
- 3 In the **Settings** window for **Cap Faces**, click  **Build Selected**.



#### Cap Faces 5 (cap5)

- 1 In the **Geometry** toolbar, click  **Defeaturing and Repair** and choose **Cap Faces**.
- 2 On the object **cap4**, select Edges 38, 39, 41, and 56 only.
- 3 In the **Settings** window for **Cap Faces**, click  **Build Selected**.



#### Cap Faces 6 (cap6)

- 1 In the **Geometry** toolbar, click  **Defeaturing and Repair** and choose **Cap Faces**.
- 2 On the object **cap5**, select Edges 36, 37, 39, and 55 only.
- 3 In the **Settings** window for **Cap Faces**, click  **Build Selected**.

#### Cap Faces 7 (cap7)

- 1 In the **Geometry** toolbar, click  **Defeaturing and Repair** and choose **Cap Faces**.
- 2 On the object **cap6**, select Edges 34, 35, 37, and 53 only.
- 3 In the **Settings** window for **Cap Faces**, click  **Build Selected**.

#### Cap Faces 8 (cap8)

- 1 In the **Geometry** toolbar, click  **Defeaturing and Repair** and choose **Cap Faces**.
- 2 In the **Settings** window for **Cap Faces**, locate the **Cap Faces** section.
- 3 Click the  **Clear Selection** button for **Bounding edges**.
- 4 On the object **cap7**, select Edges 9, 10, and 27 only.
- 5 Click  **Build Selected**.



#### Cap Faces 9 (cap9)

- 1 In the **Geometry** toolbar, click  **Defeaturing and Repair** and choose **Cap Faces**.
- 2 On the object **cap8**, select Edges 8, 10, and 25 only.
- 3 In the **Settings** window for **Cap Faces**, click  **Build Selected**.



#### Cap Faces 10 (cap10)

- 1 In the **Geometry** toolbar, click  **Defeaturing and Repair** and choose **Cap Faces**.
- 2 On the object **cap9**, select Edges 7, 8, and 23 only.
- 3 In the **Settings** window for **Cap Faces**, click  **Build Selected**.



#### Cap Faces 11 (cap11)

- 1 In the **Geometry** toolbar, click  **Defeaturing and Repair** and choose **Cap Faces**.
- 2 On the object **cap10**, select Edges 6, 7, and 21 only.
- 3 In the **Settings** window for **Cap Faces**, click  **Build Selected**.



#### Cap Faces 12 (cap12)

- 1 In the **Geometry** toolbar, click  **Defeaturing and Repair** and choose **Cap Faces**.
- 2 On the object **cap11**, select Edges 5, 6, and 19 only.
- 3 In the **Settings** window for **Cap Faces**, click  **Build Selected**.



#### Cap Faces 13 (cap13)

- 1 In the **Geometry** toolbar, click  **Defeaturing and Repair** and choose **Cap Faces**.
- 2 On the object **cap12**, select Edges 4, 5, and 17 only.
- 3 In the **Settings** window for **Cap Faces**, click  **Build Selected**.

#### Cap Faces 14 (cap14)

- 1 In the **Geometry** toolbar, click  **Defeaturing and Repair** and choose **Cap Faces**.
- 2 On the object **cap13**, select Edges 3, 4, and 15 only.
- 3 In the **Settings** window for **Cap Faces**, click  **Build Selected**.

#### Work Plane 11 (wp11)

- 1 In the **Geometry** toolbar, click  **Work Plane**.
- 2 In the **Settings** window for **Work Plane**, locate the **Plane Definition** section.
- 3 From the **Plane** list, choose **zx-plane**.
- 4 In the **y-coordinate** text field, type `c_deck`.
- 5 Click to expand the **Local Coordinate System** section. In the **Rotation** text field, type 90.
- 6 Click  **Build Selected**.

#### Work Plane 11 (wp11) > Plane Geometry

In the **Model Builder** window, click **Plane Geometry**.

#### Work Plane 11 (wp11) > Parametric Curve 1 (pc1)



- 1 In the **Work Plane** toolbar, click  **More Primitives** and choose **Parametric Curve**.

- 2 In the **Settings** window for **Parametric Curve**, locate the **Expressions** section.
- 3 In the **xw** text field, type  $s_{x1}+s_{11}*s$ .
- 4 In the **yw** text field, type  $-(5*2*s_{deck}/s_{11}*(a0*s^{0.5}-a1*s-a2*s^2+a3*s^3-a4*s^4))*s_{11}$ .
- 5 Locate the **Advanced Settings** section. Select the **Reparameterize using arc length** checkbox.
- 6 Click  **Build Selected**.

*Work Plane 11 (wp11)*

In the **Settings** window for **Work Plane**, click  **Build Selected**.



*Work Plane 12 (wp12)*

- 1 In the **Geometry** toolbar, click  **Work Plane**.
- 2 In the **Settings** window for **Work Plane**, locate the **Plane Definition** section.
- 3 From the **Plane** list, choose **zx-plane**.
- 4 In the **y-coordinate** text field, type  $c_{deck}+s_h$ .
- 5 Locate the **Local Coordinate System** section. In the **Rotation** text field, type 90.
- 6 Click  **Build Selected**.



*Work Plane 12 (wp12) > Plane Geometry*



In the **Model Builder** window, click **Plane Geometry**.

*Work Plane 12 (wp12) > Parametric Curve 1 (pc1)*



- 1 In the **Work Plane** toolbar, click  **More Primitives** and choose **Parametric Curve**.
- 2 In the **Settings** window for **Parametric Curve**, locate the **Expressions** section.
- 3 In the **xw** text field, type  $s_{x2}+s_{12}*s$ .
- 4 In the **yw** text field, type  $-(5*s_w2/s_{11}*(a0*s^{0.5}-a1*s-a2*s^2+a3*s^3-a4*s^4))*s_{12}$ .
- 5 Locate the **Advanced Settings** section. Select the **Reparameterize using arc length** checkbox.
- 6 Click  **Build Selected**.

*Work Plane 12 (wp12) > Line Segment 1 (ls1)*

- 1 In the **Work Plane** toolbar, click  **More Primitives** and choose **Line Segment**.
- 2 In the **Settings** window for **Line Segment**, locate the **Starting Point** section.
- 3 Click to select the  **Activate Selection** toggle button for **Start vertex**.
- 4 On the object **pc1**, select Point 1 only.

- 5 Locate the **Endpoint** section. Click to select the  **Activate Selection** toggle button for **End vertex**.
- 6 On the object **pc1**, select Point 2 only.
- 7 Click  **Build Selected**.



*Work Plane 12 (wp12) > Convert to Solid 1 (csol1)*

- 1 In the **Work Plane** toolbar, click  **Conversions** and choose **Convert to Solid**.
- 2 Click in the **Graphics** window and then press Ctrl+A to select both objects.
- 3 In the **Settings** window for **Convert to Solid**, click  **Build Selected**.

*Work Plane 12 (wp12)*

- 1 In the **Model Builder** window, under **Component 1 (comp1) > Geometry 1** click **Work Plane 12 (wp12)**.
- 2 In the **Settings** window for **Work Plane**, click  **Build Selected**.

*Loft 1 (loft1)*

- 1 In the **Geometry** toolbar, click  **Loft**.
- 2 In the **Settings** window for **Loft**, locate the **General** section.
- 3 Clear the **Unite with input objects** checkbox.
- 4 Click to expand the **Start Profile** section. From the **Geometric entity level** list, choose **Edge**.
- 5 On the object **wp12**, select Edge 2 only.
- 6 Click to expand the **End Profile** section. From the **Geometric entity level** list, choose **Edge**.
- 7 On the object **wp11**, select Edge 1 only.
- 8 Click  **Build Selected**.

*Work Plane 13 (wp13)*

- 1 In the **Geometry** toolbar, click  **Work Plane**.
- 2 In the **Settings** window for **Work Plane**, locate the **Plane Definition** section.
- 3 From the **Plane** list, choose **yz-plane**.
- 4 In the **x-coordinate** text field, type a+L+g2+g3.

*Work Plane 13 (wp13) > Plane Geometry*

In the **Model Builder** window, click **Plane Geometry**.

*Work Plane 13 (wp13) > Circle 1 (c1)*

- 1 In the **Work Plane** toolbar, click  **Circle**.

- 2 In the **Settings** window for **Circle**, locate the **Size and Shape** section.
- 3 In the **Radius** text field, type  $(b - (1 - \cos(\alpha)) * g2 / \sin(\alpha)) - g3 * \tan(\alpha)$ .
- 4 In the **Sector angle** text field, type 180.
- 5 Click  **Build Selected**.

*Work Plane 13 (wp13)*

- 1 In the **Model Builder** window, under **Component 1 (comp1) > Geometry 1** click **Work Plane 13 (wp13)**.
- 2 In the **Settings** window for **Work Plane**, click  **Build Selected**.



*Work Plane 14 (wp14)*

In the **Geometry** toolbar, click  **Work Plane**.



*Work Plane 14 (wp14) > Plane Geometry*

In the **Model Builder** window, click **Plane Geometry**.

*Work Plane 14 (wp14) > Parametric Curve 1 (pc1)*

- 1 In the **Work Plane** toolbar, click  **More Primitives** and choose **Parametric Curve**.
- 2 In the **Settings** window for **Parametric Curve**, locate the **Expressions** section.
- 3 In the **xw** text field, type  $r_{x1} + r_{11} * s$ .
- 4 In the **yw** text field, type  $-(5 * r_{w1} / r_{11} * (a0 * s^{0.5} - a1 * s - a2 * s^2 + a3 * s^3 - a4 * s^4)) * r_{11}$ .
- 5 Locate the **Advanced Settings** section. Select the **Reparameterize using arc length** checkbox.
- 6 Click  **Build Selected**.



*Work Plane 14 (wp14) > Parametric Curve 2 (pc2)*

- 1 In the **Work Plane** toolbar, click  **More Primitives** and choose **Parametric Curve**.
- 2 In the **Settings** window for **Parametric Curve**, locate the **Expressions** section.
- 3 In the **xw** text field, type  $r_{x1} + r_{11} * s$ .
- 4 In the **yw** text field, type  $+(5 * r_{w1} / r_{11} * (a0 * s^{0.5} - a1 * s - a2 * s^2 + a3 * s^3 - a4 * s^4)) * r_{11}$ .
- 5 Locate the **Advanced Settings** section. Select the **Reparameterize using arc length** checkbox.
- 6 Click  **Build Selected**.

*Work Plane 14 (wp14)*

In the **Settings** window for **Work Plane**, click  **Build Selected**.



*Work Plane 15 (wp15)*

- 1 In the **Geometry** toolbar, click  **Work Plane**.
- 2 In the **Settings** window for **Work Plane**, locate the **Plane Definition** section.
- 3 In the **z-coordinate** text field, type `r_h`.
- 4 Click  **Build Selected**.



*Work Plane 15 (wp15) > Plane Geometry*

In the **Model Builder** window, click **Plane Geometry**.



*Work Plane 15 (wp15) > Parametric Curve 1 (pc1)*

- 1 In the **Work Plane** toolbar, click  **More Primitives** and choose **Parametric Curve**.
- 2 In the **Settings** window for **Parametric Curve**, locate the **Expressions** section.
- 3 In the **xw** text field, type `r_x2+r_12*s`.
- 4 In the **yw** text field, type `-(5*r_w2/r_12*(a0*s^0.5-a1*s-a2*s^2+a3*s^3-a4*s^4))*r_12`.
- 5 Locate the **Advanced Settings** section. Select the **Reparameterize using arc length** checkbox.
- 6 Click  **Build Selected**.

*Work Plane 15 (wp15) > Parametric Curve 2 (pc2)*

- 1 In the **Work Plane** toolbar, click  **More Primitives** and choose **Parametric Curve**.
- 2 In the **Settings** window for **Parametric Curve**, locate the **Expressions** section.
- 3 In the **xw** text field, type `r_x2+r_12*s`.
- 4 In the **yw** text field, type `+(5*r_w2/r_12*(a0*s^0.5-a1*s-a2*s^2+a3*s^3-a4*s^4))*r_12`.
- 5 Locate the **Advanced Settings** section. Select the **Reparameterize using arc length** checkbox.
- 6 Click  **Build Selected**.

*Work Plane 15 (wp15) > Convert to Solid 1 (csol1)*



- 1 In the **Work Plane** toolbar, click  **Conversions** and choose **Convert to Solid**.
- 2 Click in the **Graphics** window and then press `Ctrl+A` to select both objects.
- 3 In the **Settings** window for **Convert to Solid**, click  **Build Selected**.

*Work Plane 15 (wp15)*



- 1 In the **Model Builder** window, under **Component 1 (comp1) > Geometry 1** click **Work Plane 15 (wp15)**.

2 In the **Settings** window for **Work Plane**, click  **Build Selected**.



#### *Loft 2 (loft2)*

- 1 In the **Geometry** toolbar, click  **Loft**.
- 2 In the **Settings** window for **Loft**, locate the **General** section.
- 3 Clear the **Unite with input objects** checkbox.
- 4 Locate the **Start Profile** section. From the **Geometric entity level** list, choose **Edge**.
- 5 On the object **wp15**, select Edge 2 only.
- 6 Locate the **End Profile** section. From the **Geometric entity level** list, choose **Edge**.
- 7 On the object **wp14**, select Edge 2 only.
- 8 Click  **Build Selected**.



#### *Loft 3 (loft3)*

- 1 In the **Geometry** toolbar, click  **Loft**.
- 2 In the **Settings** window for **Loft**, locate the **General** section.
- 3 Clear the **Unite with input objects** checkbox.
- 4 Locate the **Start Profile** section. From the **Geometric entity level** list, choose **Edge**.
- 5 On the object **wp15**, select Edge 1 only.
- 6 Locate the **End Profile** section. From the **Geometric entity level** list, choose **Edge**.
- 7 On the object **wp14**, select Edge 1 only.
- 8 Click  **Build Selected**.

#### *Rotate 1 (rot1)*

- 1 In the **Geometry** toolbar, click  **Transforms** and choose **Rotate**.
- 2 Select the objects **loft2**, **loft3**, and **wp15** only.
- 3 In the **Settings** window for **Rotate**, locate the **Rotation** section.
- 4 From the **Axis type** list, choose **x-axis**.
- 5 Click  **Range**.
- 6 In the **Range** dialog, choose **Number of values** from the **Entry method** list.
- 7 In the **Start** text field, type 0.
- 8 In the **Stop** text field, type 270.
- 9 In the **Number of values** text field, type 4.
- 10 Click **Replace**.
- 11 In the **Settings** window for **Rotate**, click  **Build Selected**.



### *Union 2 (uni2)*

- 1 In the **Geometry** toolbar, click  **Booleans and Partitions** and choose **Union**.
- 2 Select the objects **rot1(1)**, **rot1(10)**, **rot1(11)**, **rot1(12)**, **rot1(2)**, **rot1(3)**, **rot1(4)**, **rot1(5)**, **rot1(6)**, **rot1(7)**, **rot1(8)**, and **rot1(9)** only.
- 3 In the **Settings** window for **Union**, click  **Build Selected**.

### *Convert to Solid 1 (csol1)*

- 1 In the **Geometry** toolbar, click  **Conversions** and choose **Convert to Solid**.
- 2 Select the object **uni2** only.
- 3 In the **Settings** window for **Convert to Solid**, click  **Build Selected**.



### *Work Plane 16 (wp16)*

- 1 In the **Geometry** toolbar, click  **Work Plane**.
- 2 In the **Settings** window for **Work Plane**, locate the **Plane Definition** section.
- 3 In the **z-coordinate** text field, type **b\_h1**.
- 4 Click  **Build Selected**.

### *Work Plane 16 (wp16) > Plane Geometry*

In the **Model Builder** window, click **Plane Geometry**.

### *Work Plane 16 (wp16) > Parametric Curve 1 (pc1)*

- 1 In the **Work Plane** toolbar, click  **More Primitives** and choose **Parametric Curve**.
- 2 In the **Settings** window for **Parametric Curve**, locate the **Expressions** section.
- 3 In the **xw** text field, type **b\_x1+b\_11\*s**.
- 4 In the **yw** text field, type **-(5\*b\_w1/b\_11\*(a0\*s^0.5-a1\*s-a2\*s^2+a3\*s^3-a4\*s^4))\*b\_11+b\_d**.
- 5 Locate the **Advanced Settings** section. Select the **Reparameterize using arc length** checkbox.
- 6 Click  **Build Selected**.

### *Work Plane 16 (wp16) > Parametric Curve 2 (pc2)*

- 1 In the **Work Plane** toolbar, click  **More Primitives** and choose **Parametric Curve**.
- 2 In the **Settings** window for **Parametric Curve**, locate the **Expressions** section.
- 3 In the **xw** text field, type **b\_x1+b\_11\*s**.
- 4 In the **yw** text field, type **+(5\*b\_w1/b\_11\*(a0\*s^0.5-a1\*s-a2\*s^2+a3\*s^3-a4\*s^4))\*b\_11+b\_d**.

5 Locate the **Advanced Settings** section. Select the **Reparameterize using arc length** checkbox.

6 Click  **Build Selected**.

*Work Plane 16 (wp16)*

1 In the **Model Builder** window, under **Component 1 (comp1) > Geometry 1** click **Work Plane 16 (wp16)**.

2 In the **Settings** window for **Work Plane**, click  **Build Selected**.

*Work Plane 17 (wp17)*

1 In the **Geometry** toolbar, click  **Work Plane**.

2 In the **Settings** window for **Work Plane**, locate the **Plane Definition** section.

3 In the **z-coordinate** text field, type  $b\_h2$ .

4 Click  **Build Selected**.

*Work Plane 17 (wp17) > Plane Geometry*

In the **Model Builder** window, click **Plane Geometry**.

*Work Plane 17 (wp17) > Parametric Curve 1 (pc1)*

1 In the **Work Plane** toolbar, click  **More Primitives** and choose **Parametric Curve**.

2 In the **Settings** window for **Parametric Curve**, locate the **Expressions** section.

3 In the **xw** text field, type  $b\_x2+b\_12*s$ .

4 In the **yw** text field, type  $-(5*b\_w2/b\_12*(a0*s^{0.5}-a1*s-a2*s^2+a3*s^3-a4*s^4))*b\_12+b\_d$ .

5 Locate the **Advanced Settings** section. Select the **Reparameterize using arc length** checkbox.

6 Click  **Build Selected**.

*Work Plane 17 (wp17) > Parametric Curve 2 (pc2)*

1 In the **Work Plane** toolbar, click  **More Primitives** and choose **Parametric Curve**.

2 In the **Settings** window for **Parametric Curve**, locate the **Expressions** section.



3 In the **xw** text field, type  $b\_x2+b\_12*s$ .

4 In the **yw** text field, type  $+(5*b\_w2/b\_12*(a0*s^{0.5}-a1*s-a2*s^2+a3*s^3-a4*s^4))*b\_12+b\_d$ .

5 Locate the **Advanced Settings** section. Select the **Reparameterize using arc length** checkbox.

6 Click  **Build Selected**.



*Work Plane 17 (wp17) > Convert to Solid 1 (csol1)*

- 1 In the **Work Plane** toolbar, click  **Conversions** and choose **Convert to Solid**.
- 2 Click in the **Graphics** window and then press Ctrl+A to select both objects.
- 3 In the **Settings** window for **Convert to Solid**, click  **Build Selected**.



*Work Plane 17 (wp17)*

- 1 In the **Model Builder** window, under **Component 1 (comp1) > Geometry 1** click **Work Plane 17 (wp17)**.
- 2 In the **Settings** window for **Work Plane**, click  **Build Selected**.

*Loft 4 (loft4)*

- 1 In the **Geometry** toolbar, click  **Loft**.
- 2 In the **Settings** window for **Loft**, locate the **General** section.
- 3 Clear the **Unite with input objects** checkbox.
- 4 Locate the **Start Profile** section. From the **Geometric entity level** list, choose **Edge**.
- 5 On the object **wp17**, select Edge 2 only.
- 6 Locate the **End Profile** section. From the **Geometric entity level** list, choose **Edge**.
- 7 On the object **wp16**, select Edge 2 only.
- 8 Click  **Build Selected**.

*Loft 5 (loft5)*

- 1 In the **Geometry** toolbar, click  **Loft**.
- 2 In the **Settings** window for **Loft**, locate the **General** section.
- 3 Clear the **Unite with input objects** checkbox.
- 4 Locate the **Start Profile** section. From the **Geometric entity level** list, choose **Edge**.
- 5 On the object **wp17**, select Edge 1 only.
- 6 Locate the **End Profile** section. From the **Geometric entity level** list, choose **Edge**.
- 7 On the object **wp16**, select Edge 1 only.
- 8 Click  **Build Selected**.



*Union 3 (uni3)*

- 1 In the **Geometry** toolbar, click  **Booleans and Partitions** and choose **Union**.
- 2 Select the objects **cap14**, **loft1**, **loft4**, **loft5**, **wp12**, **wp16**, and **wp17** only.
- 3 In the **Settings** window for **Union**, click  **Build Selected**.



### *Delete Entities 1 (dell)*

- 1 In the **Model Builder** window, right-click **Geometry 1** and choose **Delete Entities**.
- 2 On the object **uni3**, select Boundaries 19, 20, 22, 24, 26, and 29 only.
- 3 In the **Settings** window for **Delete Entities**, click  **Build Selected**.

### *Mirror 1 (mir1)*

- 1 In the **Geometry** toolbar, click  **Transforms** and choose **Mirror**.
- 2 Select the objects **dell** and **wp13** only.
- 3 In the **Settings** window for **Mirror**, locate the **Input** section.
- 4 Select the **Keep input objects** checkbox.
- 5 Click  **Build Selected**.



### *Union 4 (uni4)*

- 1 In the **Geometry** toolbar, click  **Booleans and Partitions** and choose **Union**.
- 2 Select the objects **dell**, **mir1(1)**, **mir1(2)**, and **wp13** only.
- 3 In the **Settings** window for **Union**, click  **Build Selected**.

### *Convert to Solid 2 (csol2)*

- 1 In the **Geometry** toolbar, click  **Conversions** and choose **Convert to Solid**.
- 2 Select the object **uni4** only.
- 3 In the **Settings** window for **Convert to Solid**, click  **Build Selected**.

### *Union 5 (uni5)*

- 1 In the **Geometry** toolbar, click  **Booleans and Partitions** and choose **Union**.
- 2 Select the objects **csol1** and **csol2** only.
- 3 In the **Settings** window for **Union**, locate the **Union** section.
- 4 Clear the **Keep interior boundaries** checkbox.
- 5 Click  **Build Selected**.

Rotate the submarine to facilitate the visualization.



### *Rotate 2 (rot2)*

- 1 In the **Geometry** toolbar, click  **Transforms** and choose **Rotate**.
- 2 Select the object **uni5** only.
- 3 In the **Settings** window for **Rotate**, locate the **Rotation** section.
- 4 From the **Axis type** list, choose **x-axis**.
- 5 In the **Angle** text field, type 90.



6 Click  **Build Selected**.

The geometry is now finished. The following steps are only needed to improve the quality of the mesh.

#### *Work Plane 18 (wp18)*

- 1 In the **Geometry** toolbar, click  **Work Plane**.
- 2 In the **Settings** window for **Work Plane**, locate the **Plane Definition** section.
- 3 From the **Plane** list, choose **yz-plane**.
- 4 In the **x-coordinate** text field, type  $b_{x1} - 0.1$  [m].
- 5 Click  **Build Selected**.



#### *Partition Faces 1 (parf1)*

- 1 In the **Geometry** toolbar, click  **Booleans and Partitions** and choose **Partition Faces**.
- 2 On the object **rot2**, select Boundaries 31–34 only.
- 3 In the **Settings** window for **Partition Faces**, locate the **Partition Faces** section.
- 4 From the **Partition with** list, choose **Work plane**.
- 5 Click  **Build Selected**.

#### *Work Plane 19 (wp19)*

- 1 In the **Model Builder** window, under **Component 1 (comp1) > Geometry 1** right-click **Work Plane 18 (wp18)** and choose **Duplicate**.
- 2 In the **Settings** window for **Work Plane**, locate the **Plane Definition** section.
- 3 In the **x-coordinate** text field, type  $b_{x1} + b_{11} + 0.1$  [m].
- 4 Click  **Build Selected**.

#### *Partition Faces 2 (parf2)*

- 1 In the **Geometry** toolbar, click  **Booleans and Partitions** and choose **Partition Faces**.
- 2 On the object **parf1**, select Boundaries 37, 40, 47, and 48 only.
- 3 In the **Settings** window for **Partition Faces**, locate the **Partition Faces** section.
- 4 From the **Partition with** list, choose **Work plane**.
- 5 Click  **Build Selected**.

#### *Work Plane 20 (wp20)*

- 1 In the **Model Builder** window, under **Component 1 (comp1) > Geometry 1** right-click **Work Plane 19 (wp19)** and choose **Duplicate**.
- 2 In the **Settings** window for **Work Plane**, locate the **Plane Definition** section.

3 In the **x-coordinate** text field, type  $s_{x1} - 0.1$  [m].

4 Click  **Build Selected**.

#### *Partition Faces 3 (parf3)*

1 In the **Geometry** toolbar, click  **Booleans and Partitions** and choose **Partition Faces**.

2 On the object **parf2**, select Boundaries 27 and 29 only.

3 In the **Settings** window for **Partition Faces**, locate the **Partition Faces** section.

4 From the **Partition with** list, choose **Work plane**.

5 Click  **Build Selected**.

#### *Work Plane 21 (wp21)*

1 In the **Model Builder** window, under **Component 1 (comp1) > Geometry 1** right-click **Work Plane 20 (wp20)** and choose **Duplicate**.

2 In the **Settings** window for **Work Plane**, locate the **Plane Definition** section.

3 In the **x-coordinate** text field, type  $s_{x1} + s_{11} + 0.1$  [m].

#### *Partition Faces 4 (parf4)*

1 In the **Geometry** toolbar, click  **Booleans and Partitions** and choose **Partition Faces**.

2 On the object **parf3**, select Boundaries 59 and 60 only.

3 In the **Settings** window for **Partition Faces**, locate the **Partition Faces** section.

4 From the **Partition with** list, choose **Work plane**.

5 Click  **Build Selected**.

#### *Work Plane 22 (wp22)*

1 In the **Model Builder** window, under **Component 1 (comp1) > Geometry 1** right-click **Work Plane 21 (wp21)** and choose **Duplicate**.

2 In the **Settings** window for **Work Plane**, locate the **Plane Definition** section.

3 In the **x-coordinate** text field, type  $s_{x1} + 3 * s_{11} / 10 - 1.25$  [m].

#### *Partition Faces 5 (parf5)*

1 In the **Geometry** toolbar, click  **Booleans and Partitions** and choose **Partition Faces**.

2 On the object **parf4**, select Boundaries 50, 51, 53, and 54 only.

3 In the **Settings** window for **Partition Faces**, locate the **Partition Faces** section.



4 From the **Partition with** list, choose **Work plane**.

5 Click  **Build Selected**.

### *Work Plane 23 (wp23)*

- 1 In the **Model Builder** window, under **Component 1 (comp1) > Geometry 1** right-click **Work Plane 22 (wp22)** and choose **Duplicate**.
- 2 In the **Settings** window for **Work Plane**, locate the **Plane Definition** section.
- 3 In the **x-coordinate** text field, type  $s_{x1}+3*s_{11}/10+1.25[m]$ .

### *Partition Faces 6 (parf6)*

- 1 In the **Geometry** toolbar, click  **Booleans and Partitions** and choose **Partition Faces**.
- 2 On the object **parf5**, select Boundaries 59 and 62–64 only.
- 3 In the **Settings** window for **Partition Faces**, locate the **Partition Faces** section.
- 4 From the **Partition with** list, choose **Work plane**.
- 5 Click  **Build Selected**.

### *Form Union (fin)*

- 1 In the **Model Builder** window, click **Form Union (fin)**.
- 2 In the **Settings** window for **Form Union/Assembly**, click  **Build Selected**.

Add some selections based on coordinates for the virtual operations.

### *Box Selection 1 (boxsel1)*

- 1 In the **Geometry** toolbar, click  **Selections** and choose **Box Selection**.
- 2 In the **Settings** window for **Box Selection**, locate the **Geometric Entity Level** section.
- 3 From the **Level** list, choose **Edge**.
- 4 Locate the **Box Limits** section. In the **x minimum** text field, type 11.5.
- 5 In the **x maximum** text field, type 12.5.
- 6 In the **y minimum** text field, type -2.
- 7 In the **y maximum** text field, type 2.
- 8 In the **z minimum** text field, type 3.9.
- 9 In the **z maximum** text field, type 4.1.
- 10 Locate the **Output Entities** section. From the **Include entity if** list, choose **All vertices inside box**.

### *Box Selection 2 (boxsel2)*

- 1 Right-click **Box Selection 1 (boxsel1)** and choose **Duplicate**.
- 2 In the **Settings** window for **Box Selection**, locate the **Box Limits** section.
- 3 In the **x minimum** text field, type 21.5.

- 4 In the **x maximum** text field, type 22.9.
- 5 In the **y minimum** text field, type -1.25.
- 6 In the **y maximum** text field, type -1.18.

#### *Box Selection 3 (boxsel3)*

- 1 Right-click **Box Selection 2 (boxsel2)** and choose **Duplicate**.
- 2 In the **Settings** window for **Box Selection**, locate the **Box Limits** section.
- 3 In the **y minimum** text field, type 1.18.
- 4 In the **y maximum** text field, type 1.25.



#### *Box Selection 4 (boxsel4)*

- 1 Right-click **Box Selection 3 (boxsel3)** and choose **Duplicate**.
- 2 In the **Settings** window for **Box Selection**, locate the **Box Limits** section.
- 3 In the **x minimum** text field, type 22.9.
- 4 In the **x maximum** text field, type 24.5.

#### *Box Selection 5 (boxsel5)*

- 1 Right-click **Box Selection 4 (boxsel4)** and choose **Duplicate**.
- 2 In the **Settings** window for **Box Selection**, locate the **Box Limits** section.
- 3 In the **y minimum** text field, type -1.25.
- 4 In the **y maximum** text field, type -1.18.
- 5 Click  **Build Selected**.

#### *Union Selection 1 (unisel1)*

- 1 In the **Geometry** toolbar, click  **Selections** and choose **Union Selection**.
- 2 In the **Settings** window for **Union Selection**, locate the **Geometric Entity Level** section.
- 3 From the **Level** list, choose **Edge**.
- 4 Locate the **Input Entities** section. Click  **Add**.
- 5 In the **Add** dialog, in the **Selections to add** list, choose **Box Selection 2**, **Box Selection 3**, **Box Selection 4**, and **Box Selection 5**.
- 6 Click **OK**.

#### *Ignore Edges 1 (igel1)*



- 1 In the **Geometry** toolbar, click  **Virtual Operations** and choose **Ignore Edges**.
- 2 In the **Settings** window for **Ignore Edges**, locate the **Input** section.
- 3 From the **Edges to ignore** list, choose **Union Selection 1**.

4 Click  **Build Selected**.





#### *Collapse Edges I (cleI)*

- 1 In the **Geometry** toolbar, click  **Virtual Operations** and choose **Collapse Edges**.
- 2 In the **Settings** window for **Collapse Edges**, locate the **Input** section.
- 3 From the **Edges to collapse** list, choose **Box Selection I**.
- 4 In the **Geometry** toolbar, click  **Build All**.

#### *Ignore Vertices I (igvI)*

- 1 In the **Geometry** toolbar, click  **Virtual Operations** and choose **Ignore Vertices**.
- 2 Click in the **Graphics** window and then press Ctrl+D to clear all objects.
- 3 Click the  **Select All** button in the **Graphics** toolbar.
- 4 In the **Settings** window for **Ignore Vertices**, click  **Build Selected**.

#### *Convert to COMSOL I (ccomI)*

- 1 In the **Geometry** toolbar, click  **Conversions** and choose **Convert to COMSOL**.
- 2 Select the object **parf6** only.
- 3 In the **Geometry** toolbar, click  **Build All**.
- 4 Click  **Export**.
- 5 In the **Model Builder** window, click **Geometry I**.
- 6 In the **Export[noun]** window for **Geometry**, locate the **Export** section.
- 7 In the **Filename** text field, type `submarine_target_strength.mphbin`.
- 8 Click the **Export entire finalized geometry** button.
- 9 Click  **null** to produce the MPHBIN-file that is used at the beginning of the tutorial.