



Model created in COMSOL Multiphysics 6.4

Sound Transmission Loss Through a Concrete Wall

Introduction

This model presents a practical and efficient method to compute the sound transmission loss (STL) through a building component; specifically, this example treats the case of a concrete wall. The method used here is valid as long as the component has little influence on the acoustic field on the source side. The method is based on assuming an ideal diffuse field on the source side and an ideal anechoic termination on the receiver side of the concrete wall. In typical measurement setups, the diffuse sound field is generated in a reverberation room. At low frequencies, the fields that can be obtained are less than perfectly diffuse. The measured STL will therefore to some extent depend on the experimental conditions. From the approach used in this model, you can extract an ideal, experiment-independent STL. The obtained results are compared to published experimental data and show good agreement.

Model Definition

In this tutorial, the sound transmission loss (STL) through a concrete wall is modeled using an approach that is well suited for numerical simulations. A review of STL measurement techniques and theory is given below in order to motivate the simulation approach used here. Following this discussion, the method is described in detail.

SOUND TRANSMISSION LOSS (STL)

The STL through a building component, like a door, a window, a wall segment, or a sound insulation structure, is defined as the ratio expressed in dB of the total incident power P_{in} on the structure relative to the total transmitted power P_{tr} :

$$\text{STL} = 10 \log_{10} \left(\frac{P_{\text{in}}}{P_{\text{tr}}} \right) \quad (1)$$

The STL is defined for conditions where the acoustic field on the source side is diffuse. Several standards exist for the measurement of the STL, for example, ASTM E90 or ISO 10140. Common to the methods is that they are devised in order to directly or indirectly measure the incident and transmitted power. Typically, a so-called two-room method is used. The two most common configurations both use a reverberation room on the source side. The first also uses a reverberation room on the receiver side (reverberant-reverberant) while the second uses an anechoic room on the receiver side (reverberant-anechoic). The two configurations are sketched in [Figure 1](#).

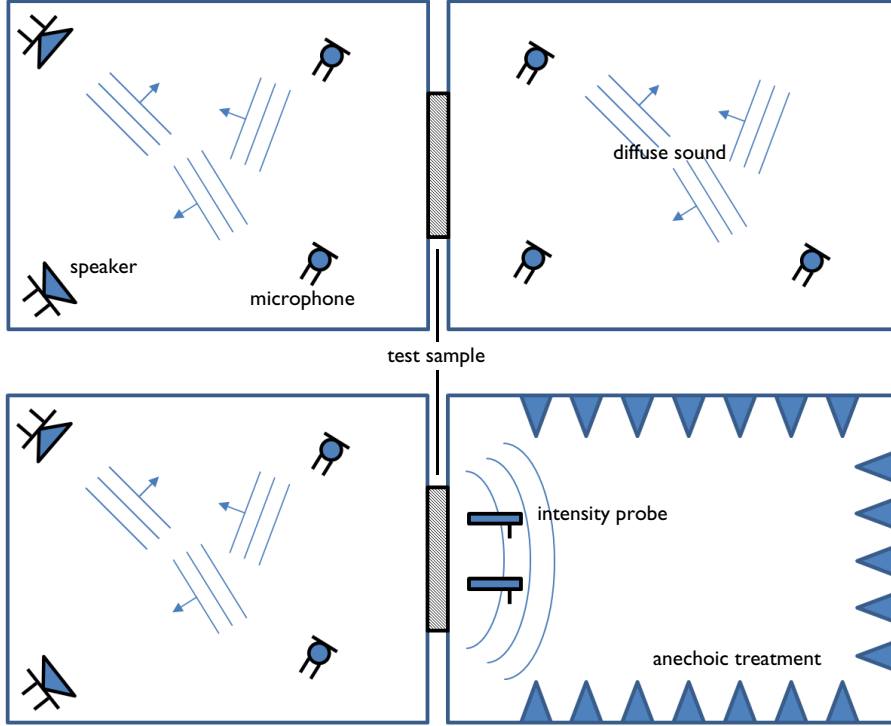

Figure 1: The two variations of the two-room configuration for measuring the sound transmission loss. Top: source and receiver reverberation rooms. Bottom: source reverberation room and receiver anechoic room.

In both cases, the incident power on the source side is computed as

$$P_{\text{in}} = \frac{p_{\text{rms}}^2}{4\rho_0 c_0} S_s \quad (2)$$

where S_s is the area of the test surface on the source side (the area of the concrete wall tested), p_{rms} is the RMS pressure in the source room, ρ_0 is the air density, and c_0 is the speed of sound in air. This expression is derived by considering the incident power on a surface in an ideal diffuse acoustic field, see [Ref. 1](#) and [Ref. 2](#).

The expressions used to compute the incident and transmitted power for the reverberant-reverberant case are only valid as long as the acoustic field is diffuse. A measure for the upper limit of modal behavior is given by the Schroeder frequency

$$f_s = 2000 \sqrt{\frac{T_{60}}{V}} \quad (3)$$

where V is the room volume and T_{60} is the reverberation time; see [Ref. 1](#). A room of volume V is said to be acoustically large when the studied frequency f is larger than the Schroeder frequency, giving the condition

$$V > \left(\frac{2000}{f}\right)^2 T_{60} \quad (4)$$

Reverberant–Reverberant Setup

In the setup where the receiver room is a reverberation room ([Figure 1](#) top) and the sound field is assumed diffuse, the transmitted power is given by

$$P_{\text{tr}} = \frac{p_{\text{rms}}^2}{4\rho_0 c_0} A_r \quad A_r = \sum_i S_i \alpha_i \quad (5)$$

where p_{rms} is the RMS pressure in the receiver room and A_r is the receiver room absorption area, that is, the sum of products between each surface area S_i and its absorption coefficient α_i . The expression stems from an energy balance consideration where the total absorbed energy is equal to the radiated energy of the source. Combining [Equation 2](#) and [Equation 5](#) gives the expression for the STL for the reverberant-reverberant setup

$$\text{STL} = \text{SPL}_s - \text{SPL}_r + 10 \log_{10} \left(\frac{S_s}{A_r} \right) \quad (6)$$

where SPL_s and SPL_r are the average sound pressure levels in the source and the receiver room, respectively. Averaging is done on the squared pressure before transforming to the dB scale.

Note that a correction to [Equation 5](#) is sometimes introduced based on the Waterhouse expression. In a room with a diffuse field, the RMS pressure at the walls will be larger by a factor 2 because each incident wave is coherent with its corresponding reflected wave, see [Ref. 2](#). The corrected expression reads

$$P_{\text{tr}} = \frac{p_{\text{rms}}^2}{\rho_0 c_0} V_r \left(1 + \frac{S_r \lambda}{8V_r} \right) \frac{13.8}{\text{EDT}} \quad (7)$$

where EDT is the early decay time, V_r is the receiver room volume, S_r the receiver room surface area, and λ is the wavelength.

Reverberant–Anechoic Setup

In the reverberant-anechoic configuration (Figure 1 bottom), the transmitted power is directly measured on the receiver side using an intensity probe. The measurement is performed in several locations in front of the test element and averaged. The transmitted power is then simply given by

$$P_{tr} = S_r I_{tr} \quad (8)$$

combining this expression with Equation 1 and Equation 2 gives

$$STL = SPL_s - SIL_{tr} + 10 \log_{10} \left(\frac{S_s}{S_r} \right) - 6.14 \quad (9)$$

SIL_{tr} is the transmitted sound intensity level, and for flat samples $S_s = S_r$. The numeric constant stems directly from the definitions of SPL and SIL and the equations for the power, it is expressed as

$$10 \log_{10} \left(\frac{1 p_{ref}^2}{4 I_{ref} \rho_0 c_0} \right) \approx -6.14 \quad (10)$$

where $p_{ref} = 20 \mu\text{Pa}$, $I_{ref} = 10^{-12} \text{ W/m}$, $\rho_0 = 1.2 \text{ kg/m}^3$, and $c_0 = 343 \text{ m/s}$.

ESTIMATION MODEL FOR THE STL

The STL for isotropic panels made of an elastic material like the wall studied here has a general frequency dependent behavior that is sketched in Figure 2; see Ref. 3. At low frequencies, below the first mechanical resonance f_{11} of the structure, the STL is controlled by stiffness. At and around the resonance the STL drops drastically as the structure acts as an optimal transmitter (dips can also occur for the second mode). Above the first resonance the STL becomes controlled by mass. This behavior covers a relatively large frequency band where the STL increases with 6 dB per octave. Then, the STL decreases around the critical frequency f_c , in a region called the coincidence region. Coincidence happens when the wavelengths of the pressure waves in the fluid are comparable to the wavelengths of the flexural waves in the structure. Above this region the

STL increases. It is first controlled by damping with a 9 dB per octave increase, before it approaches the mass law behavior again.

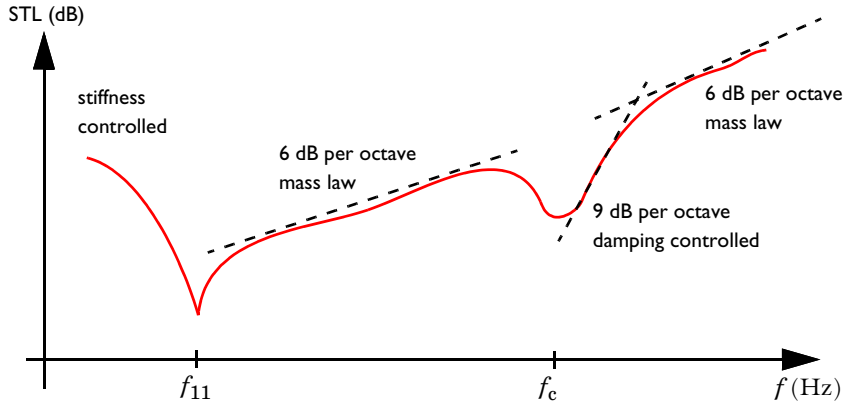

Figure 2: Schematic representation of the frequency dependency of the STL for isotropic panels.

Several analytical prediction models exist for the STL of simply supported panels, see Ref. 3. One mass law model for 1/3 octave STL values, called Sharp's equation, is given as

$$\text{STL} = 10 \log_{10} \left(1 + \left(\frac{\pi f m}{\rho_0 c_0} \right)^2 \right) - 5.5 \text{ dB} \quad (11)$$

where $m = \rho T$ is the mass per unit area of the structure, ρ is the density of the structure, and T is the thickness of the panel (here the wall, see Figure 3). Note that the predicted STL from Sharp's equation will in practice exceed the actual STL. This is because the equation assumes an ideal limp panel and does not take into account the panel stiffness. This same trend is seen in the model results discussed below. The slope in the mass law region will obey the 6 dB per octave trend. A doubling of the wall thickness will double the value of m and thus results in a 6 dB increase in STL for a given frequency.

SIMULATION MODEL SETUP

When simulating the STL it is preferable to avoid modeling the source and receiver rooms as this would be computationally extremely expensive. Instead, the setup is based on assuming an ideal diffuse field on the source side and an ideal anechoic termination on the receiver side of the test sample. The model also assumes that the test sample has little influence on the sound field on the source side. This is true for relatively stiff structures with low acoustic absorption properties. This is the case for the concrete wall studied in this example. The sound field on the source side can then be defined as a sum of $2N$

uncorrelated plane waves moving in random directions. It can also be assumed that one half of these waves travels in the negative x direction and the other half in the positive x direction. Knowing that the concrete wall is located in the $x = 0$ plane, only the waves traveling in the positive x direction contribute to the incident pressure on the wall surface. The source room pressure field traveling in the positive x direction is then

$$p_{x, \text{room}} = \frac{A}{\sqrt{2N}} \sum_{n=1}^N \exp(-i(k_{n,x}x + k_{n,y}y + k_{n,z}z)) \exp(i\Phi_n) \quad (12)$$

$$k_{n,x} = \cos(\theta_n)$$

$$k_{n,y} = \sin(\theta_n) \cos(\varphi_n)$$

$$k_{n,z} = \sin(\theta_n) \sin(\varphi_n)$$

where the polar angles $0 \leq \theta_n \leq \pi/2$ and $0 \leq \varphi_n \leq 2\pi$ as well as the phase $0 \leq \Phi_n \leq 2\pi$ are independent random numbers and A is the amplitude of the plane waves; φ_n and Φ_n are taken directly from uniform distributions, whereas θ_n is obtained as $\theta_n = a \cos(q_n)$, q_n being a random variable with uniform distribution between 0 and 1. This ensures a uniform distribution of wave numbers over the desired hemisphere. In the model, a new set of random numbers is generated for each n in the sum. The $1/\sqrt{2N}$ term ensures that the field has a constant intensity for any choice of N . Because the plane waves are uncorrelated, the total mean square pressure in the source room is $p_{\text{rms}}^2 = |2p_{x, \text{room}}|^2/2$, with the term $2p_{x, \text{room}}$ accounting for the total diffuse field (positive and negative x directions). The theoretical limit for large N of the mean square pressure in the room (away from walls) is $p_{\text{rms,th}}^2 = |A|^2/2$.

The concrete wall is located at $x = 0$, where the incident diffuse field is reflected. The reflected component of the field is

$$p_{\text{refl}} = \frac{A}{\sqrt{2N}} \sum_{n=1}^N \exp(-i(-k_{n,x}x + k_{n,y}y + k_{n,z}z)) \exp(i\Phi_n). \quad (13)$$

The reflected field is coherent with the incident field, as discussed for [Equation 5](#). At the surface of the concrete wall, the total pressure load applied to the structure is the sum of the incident and reflected pressures:

$$P_{\text{wall}} = P_{x, \text{room}} + P_{\text{refl}} \quad (14)$$

In the model, the room pressure, the reflected pressure, and wall pressures are defined as variables under **Component I > Definitions**.

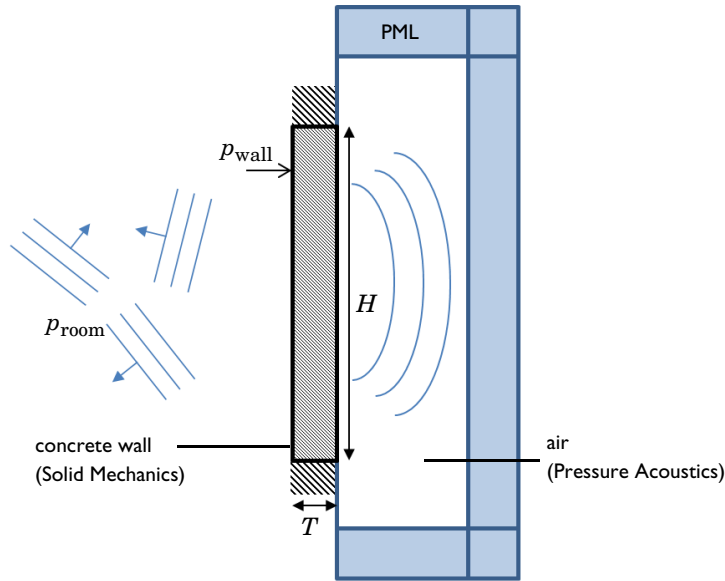

Figure 3: Model setup of the concrete wall with an ideal diffuse field on the source side and an ideal anechoic termination on the receiver side.

The wall pressure p_{wall} is applied as a load on the source side of the concrete wall. On the receiver side, a perfect anechoic room is modeled using an air domain terminated by a perfectly matched layer (PML). The model setup is sketched in [Figure 3](#).

The concrete wall has a height of $H = 4.37$ m, a width of $W = 2.84$ m, and a thickness of $T = 203$ mm. The density of the concrete is $\rho = 2275$ kg/m³, its Young’s modulus is $E = 31.6$ GPa, its Poisson’s ratio is $\nu = 0.2$, and a typical value of 0.01 is used as the isotropic loss factor. The wall size and material data is taken from the test configuration 76–77 described in [Ref. 4](#). The wall is assumed to be fixed at its outer boundary and placed in an ideal surrounding wall that does not contribute to the STL.

Note that the fixed constraint used here is different from the “simply supported” condition (a hinge-like condition) often used in the analytical prediction models. To precisely predict measurements or model the behavior of building components in-situ a good description of the outer boundary conditions is of course required. The condition used will, for example, have a significant influence on the low-frequency stiffness controlled behavior of the STL.

Results and Discussion

The incident intensity distribution on the concrete wall is depicted in [Figure 4](#), evaluated at 125 Hz, 250 Hz, 500 Hz, and 1000 Hz. The distribution is not dependent on the solved model but only on the randomness and number of terms in the expression for the room pressure field $p_{x, \text{room}}$ from [Equation 12](#).

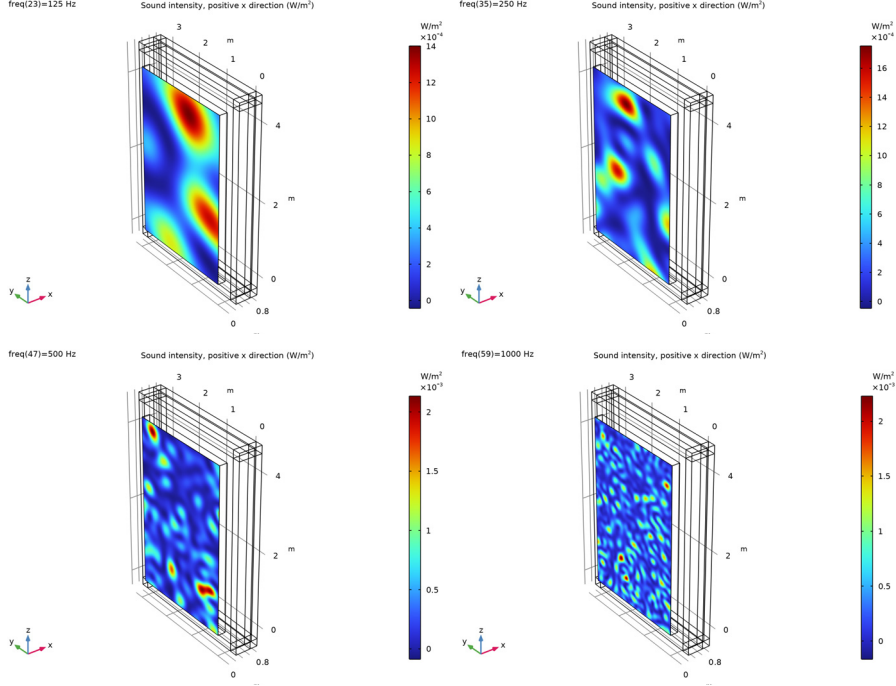

Figure 4: The incident sound intensity evaluated on the concrete wall surface.

The incident intensity on the test sample is computed using the definition of sound intensity with the incident sound pressure and particle velocity as

$$I_{x, \text{in}} = \frac{1}{2} \text{Re}(p_{x, \text{room}} v_{x, \text{room}}^*) \quad (15)$$

$$v_{x, \text{room}} = \frac{-1}{i\omega\rho_0} \frac{\partial p_{x, \text{room}}}{\partial x}$$

The spatial distribution of the transmitted (radiated) sound intensity is displayed in [Figure 5](#), for the same frequencies as the incident intensity. The transmitted intensity

depends on the solved problem and is computed as the total intensity at the concrete surface on the receiver side. It is given as

$$I_{x, \text{tr}} = \frac{1}{2} \text{Re}(p_t(i\omega u)^*) \quad (16)$$

where p_t is the total acoustic pressure and u is the structural displacement in the x direction. Both variables are solved for in the model.

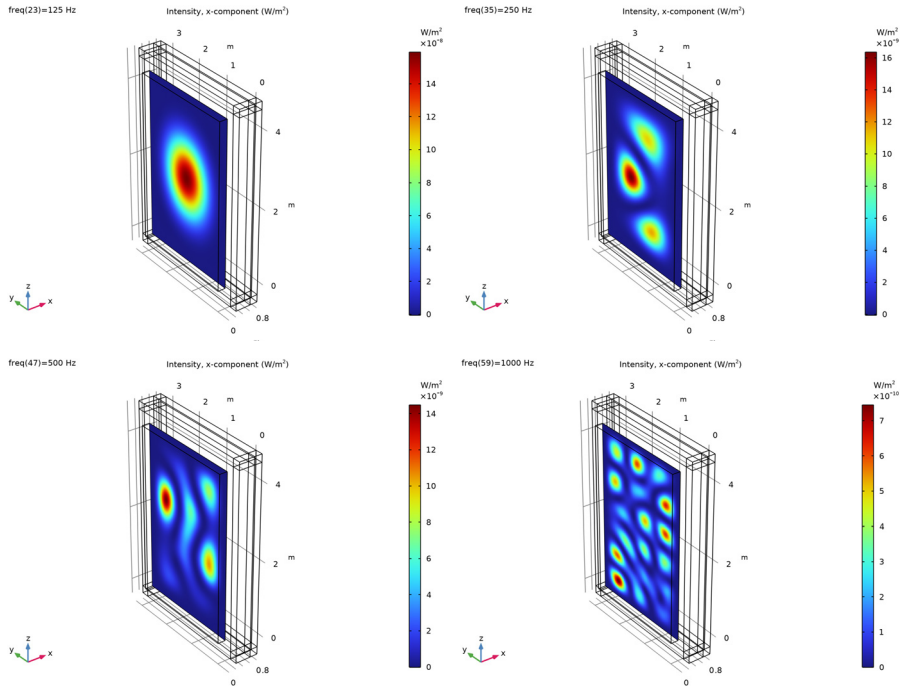

Figure 5: The transmitted sound intensity evaluated on the concrete wall surface.

The displacement of the concrete wall as well as the sound pressure in the receiver room are shown in [Figure 6](#) for the same four frequencies. Comparing this result to [Figure 5](#), it

is evident that the transmitted intensity field is controlled by the displacement of the structure.

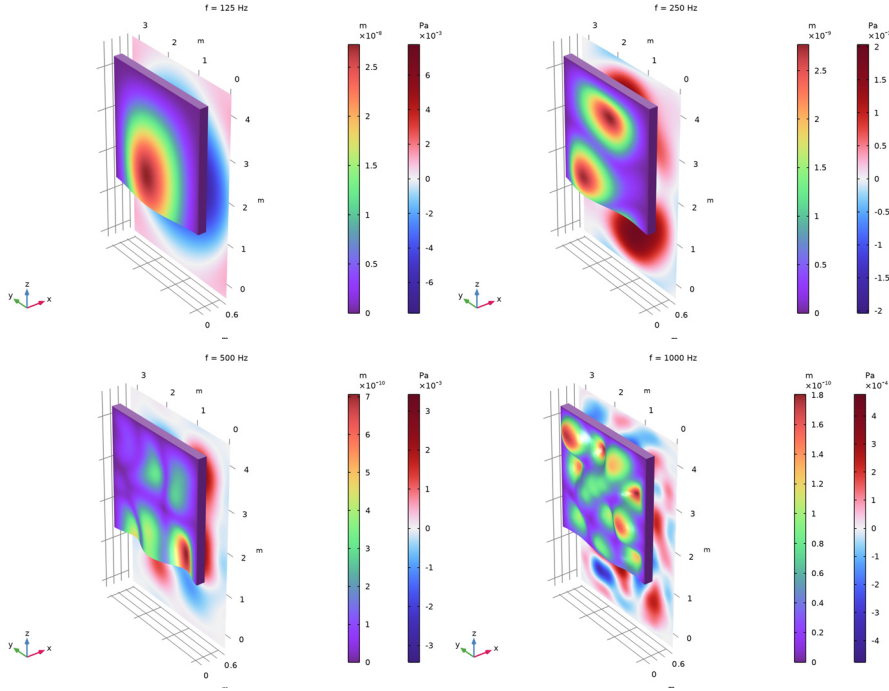

Figure 6: Displacement of the concrete wall and sound pressure on the receiver side.

At low frequencies, the displacement distribution is strongly dictated by the possible structural modes shown in Figure 7. For example, the displacement at 125 Hz is closely related to the first mode, while the third mode dominates the displacement at 250 Hz.

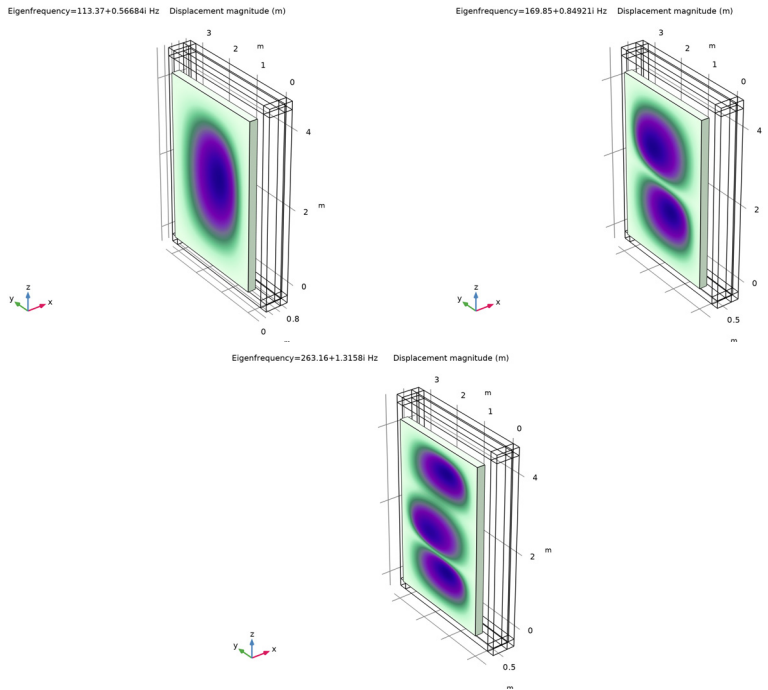

Figure 7: The first three modes of the structure.

The sound transmission loss (STL), computed using Equation 1, Equation 2, and Equation 8, is plotted in Figure 8 and Figure 9. The STL is depicted as a continuous line (evaluated for all the computed frequencies) as well as in octave bands or 1/3 octave bands, respectively. Both graphs also include the typically measured STL. The data is adapted from Ref. 4 and shows good agreement.

The two dips found in the STL curve correspond to the first two structural modes seen in Figure 7. They occur at $f_{11} = 113$ Hz and $f_{12} = 170$ Hz. Below these frequencies the STL is controlled by stiffness and depends highly on the boundary conditions applied to the structure. The mass law behavior applies above these.

In Figure 9 the estimated STL using Sharp's model from Equation 11 is also plotted in the region where the mass law applies. Despite lower values, the computed STL is seen to follow the slope of the estimate with a 6 dB per octave increase. This is expected as Sharp's equation assumes a limp structure and does not include the stiffness effects.

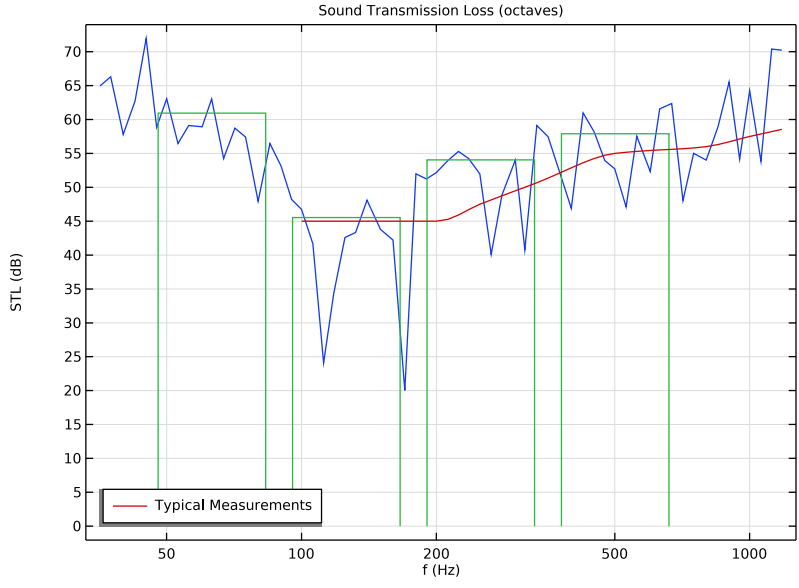

Figure 8: Sound transmission loss (STL) through the concrete wall with octave bands.

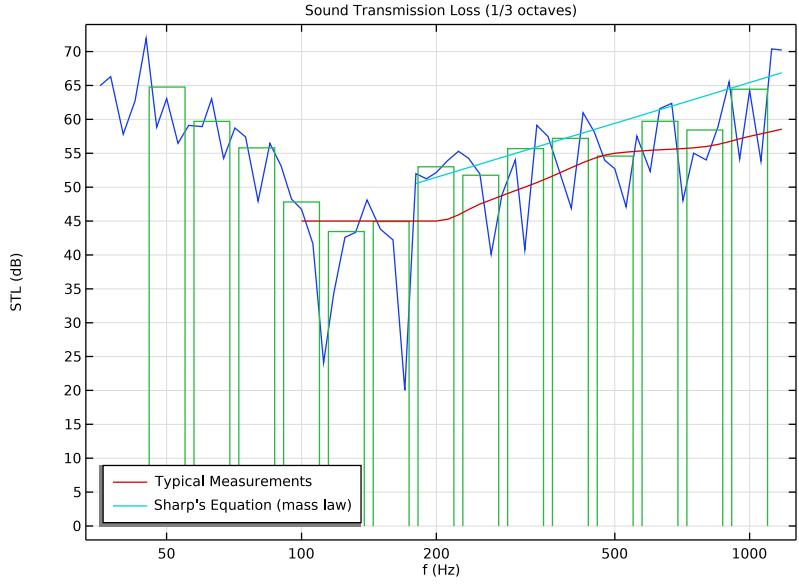

Figure 9: Sound transmission loss (STL) through the concrete wall with 1/3 octave bands.

Finally, three different methods to compute the incident power on the wall are compared in Figure 10. The blue graph shows the value given by the surface integral of Equation 15. The green and red graphs represent the values given by Equation 2 where the RMS pressures are calculated respectively from the source room sound field and from the theoretical diffuse field limit. The large fluctuations at low frequencies, where the wavelength is comparable to the wall size, indicate that the diffuse sound field assumption does not hold. In measurement conditions, the sound field would also not be diffuse at these low frequencies.

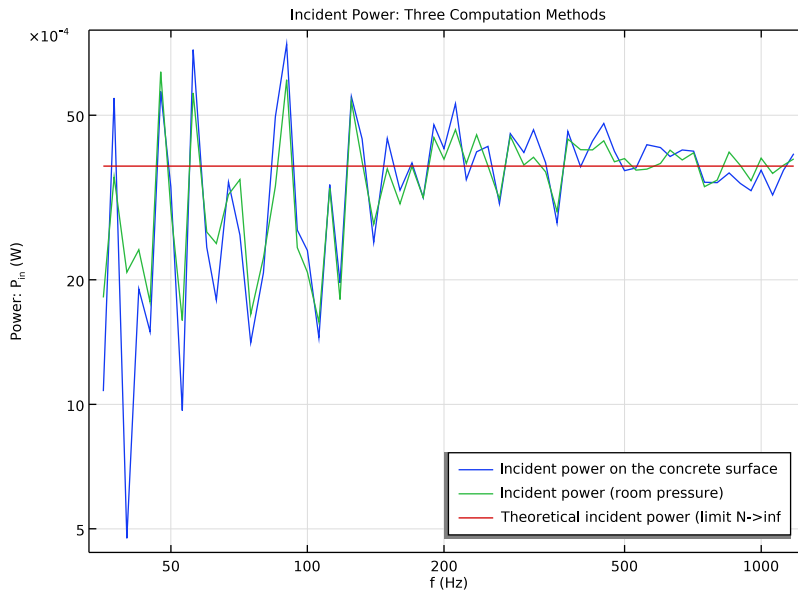

Figure 10: The incident power on the wall evaluated with three different methods.

Notes About the COMSOL Implementation

The model is based on several assumptions:

- The sound field in the source room is perfectly diffuse.
- The acoustic behavior in the receiver room is perfectly anechoic.
- The test sample under analysis has a negligible influence on the sound field in the source room.

If the test sample does not meet the last requirement, the acoustics of the source room needs to be modeled and coupled with the structure in order to compute the sound transmission loss.

References

1. H. Kuttruff, *Room Acoustics*, CRC Press, Fifth Edition, 2009.
2. F. Jacobsen, “The Sound Field in a Reverberation Room,” Lecture Note no. 31261, Acoustic Technology, Technical University of Denmark, 2011.
3. D.A. Bies, C. Hansen, and C. Howard, “Engineering Noise Control,” 5th Edition, CRC Press, 2017.
4. A. Litvin and H.W. Belliston, “Sound Transmission Loss Through Concrete and Concrete Masonry Walls,” *American Concrete Institute, Journal Proceedings*, vol. 45, pp. 641–646, 1978.

Application Library path: Acoustics_Module/Building_and_Room_Acoustics/sound_transmission_loss_concrete



Modeling Instructions

From the **File** menu, choose **New**.

NEW

In the **New** window, click  **Model Wizard**.

MODEL WIZARD

- 1 In the **Model Wizard** window, click  **3D**.
- 2 In the **Select Physics** tree, select **Acoustics** > **Acoustic–Structure Interaction** > **Acoustic–Solid Interaction, Frequency Domain**.
- 3 Click **Add**.
- 4 Click  **Study**.
- 5 In the **Select Study** tree, select **General Studies** > **Frequency Domain**.
- 6 Click  **Done**.



GLOBAL DEFINITIONS

Parameters 1

- 1 In the **Model Builder** window, under **Global Definitions** click **Parameters 1**.
- 2 In the **Settings** window for **Parameters**, locate the **Parameters** section.
- 3 Click  **Load from File**.
- 4 Browse to the model's Application Libraries folder and double-click the file `sound_transmission_loss_concrete_parameters.txt`.

Create an interpolation function that contains typical measurement data of the STL for the concrete wall.

Interpolation 1 (int1)

- 1 In the **Home** toolbar, click  **Functions** and choose **Global > Interpolation**.
- 2 In the **Settings** window for **Interpolation**, locate the **Definition** section.
- 3 From the **Data source** list, choose **File**.
- 4 Click  **Browse**.
- 5 Browse to the model's Application Libraries folder and double-click the file `sound_transmission_loss_concrete_measurement_data.txt`.
- 6 Locate the **Data Column Settings** section. In the table, click to select the cell at row number 2 and column number 1.
- 7 In the **Name** text field, type `STL_typical`.
- 8 Locate the **Definition** section. Click  **Import**.
- 9 Locate the **Interpolation and Extrapolation** section. From the **Interpolation** list, choose **Piecewise cubic**.
- 10 Locate the **Units** section. In the **Argument** table, enter the following settings:

Argument	Unit
t	Hz

- 11 In the **Function** table, enter the following settings:

Function	Unit
STL_typical	dB

GEOMETRY I

Block 1 (blk1)

- 1 In the **Geometry** toolbar, click  **Block**.
- 2 In the **Settings** window for **Block**, locate the **Size and Shape** section.
- 3 In the **Width** text field, type T.
- 4 In the **Depth** text field, type W.
- 5 In the **Height** text field, type H.

Block 2 (blk2)

- 1 In the **Geometry** toolbar, click  **Block**.
- 2 In the **Settings** window for **Block**, locate the **Size and Shape** section.
- 3 In the **Width** text field, type $3*T$.
- 4 In the **Depth** text field, type $W+4*T$.
- 5 In the **Height** text field, type $H+4*T$.
- 6 Locate the **Position** section. In the **x** text field, type T.
- 7 In the **y** text field, type $-2*T$.
- 8 In the **z** text field, type $-2*T$.
- 9 Click to expand the **Layers** section. In the table, enter the following settings:

Layer name	Thickness (m)
Layer 1	T

- 10 Find the **Layer position** subsection. Select the **Right** checkbox.
- 11 Select the **Front** checkbox.
- 12 Select the **Back** checkbox.
- 13 Select the **Top** checkbox.

14 Click  **Build All Objects**.

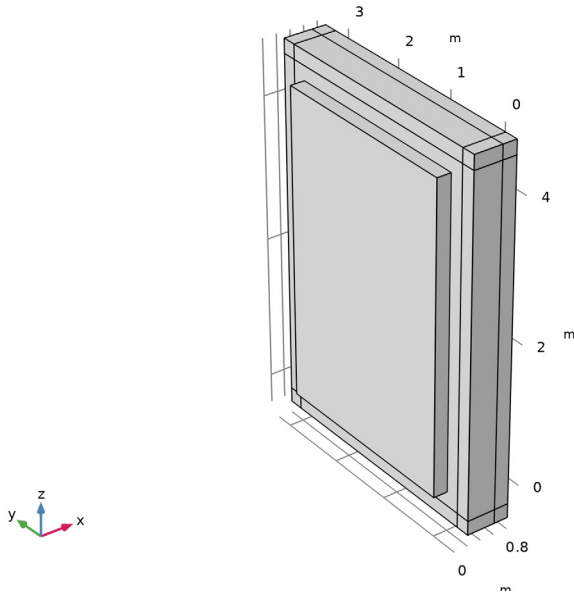

PRESSURE ACOUSTICS, FREQUENCY DOMAIN (ACPR)

- 1 In the **Model Builder** window, under **Component 1 (comp1)** click **Pressure Acoustics, Frequency Domain (acpr)**.
- 2 Select Domains 2–19 only.

SOLID MECHANICS (SOLID)

- 1 In the **Model Builder** window, under **Component 1 (comp1)** click **Solid Mechanics (solid)**.
- 2 In the **Settings** window for **Solid Mechanics**, locate the **Domain Selection** section.
- 3 Click  **Clear Selection**.
- 4 Select Domain 1 only.

MULTIPHYSICS



Acoustic–Structure Boundary 1 (asb1)

- 1 Click the  **Wireframe Rendering** button in the **Graphics** toolbar.

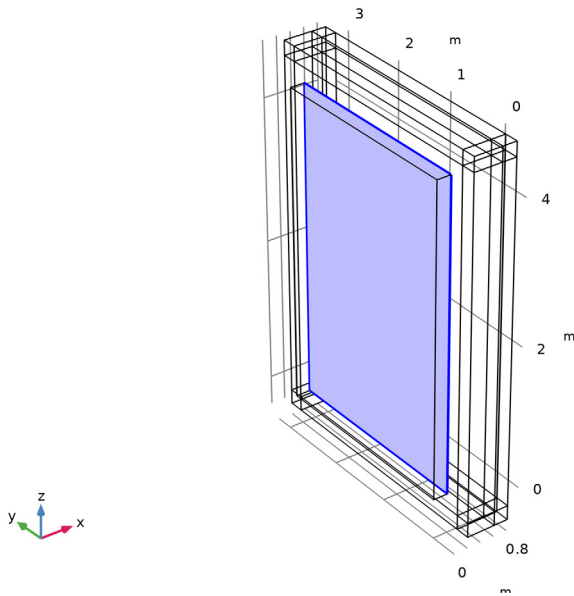
- 2 In the **Model Builder** window, under **Component 1 (comp1) > Multiphysics** click **Acoustic-Structure Boundary 1 (asb1)**.



ADD MATERIAL

- 1 In the **Materials** toolbar, click  **Add Material** to open the **Add Material** window.
- 2 Go to the **Add Material** window.
- 3 In the tree, select **Built-in > Air**.
- 4 Click the **Add to Component** button in the window toolbar.
- 5 In the **Materials** toolbar, click  **Add Material** to close the **Add Material** window.

MATERIALS

Concrete

- 1 In the **Model Builder** window, under **Component 1 (comp1)** right-click **Materials** and choose **Blank Material**.
- 2 In the **Settings** window for **Material**, type **Concrete** in the **Label** text field.
- 3 Select Domain 1 only.

4 Locate the **Material Contents** section. In the table, enter the following settings:

Property	Variable	Value	Unit	Property group
Young's modulus	E	31.6e9	Pa	Young's modulus and Poisson's ratio
Poisson's ratio	nu	0.2	l	Young's modulus and Poisson's ratio
Density	rho	2275	kg/m ³	Basic

DEFINITIONS

Variables: Diffuse Field

- 1 In the **Model Builder** window, under **Component 1 (comp1)** right-click **Definitions** and choose **Variables**.
- 2 In the **Settings** window for **Variables**, type Variables: Diffuse Field in the **Label** text field.
- 3 Locate the **Variables** section. Click  **Load from File**.
- 4 Browse to the model's Application Libraries folder and double-click the file sound_transmission_loss_concrete_variables_diffuse.txt.

Variables: STL

- 1 In the **Model Builder** window, right-click **Definitions** and choose **Variables**.
- 2 In the **Settings** window for **Variables**, type Variables: STL in the **Label** text field.
- 3 Locate the **Variables** section. Click  **Load from File**.
- 4 Browse to the model's Application Libraries folder and double-click the file sound_transmission_loss_concrete_variables_stl.txt.

Random 1 (rn1)

- 1 In the **Definitions** toolbar, click  **More Functions** and choose **Random**.
- 2 In the **Settings** window for **Random**, type costheta_rnd in the **Function name** text field.
- 3 Locate the **Parameters** section. In the **Number of arguments** text field, type 4.
- 4 In the **Mean** text field, type 0.5.

Random 2 (rn2)

- 1 In the **Definitions** toolbar, click  **More Functions** and choose **Random**.
- 2 In the **Settings** window for **Random**, type phi_rnd in the **Function name** text field.
- 3 Locate the **Parameters** section. In the **Number of arguments** text field, type 4.

- 4 In the **Mean** text field, type π .
- 5 In the **Range** text field, type $2*\pi$.

Random 3 (rn3)

- 1 In the **Definitions** toolbar, click  **More Functions** and choose **Random**.
- 2 In the **Settings** window for **Random**, type `phase_rnd` in the **Function name** text field.
- 3 Locate the **Parameters** section. In the **Number of arguments** text field, type 4.
- 4 In the **Mean** text field, type π .
- 5 In the **Range** text field, type $2*\pi$.

Integration 1 (intop1)

- 1 In the **Definitions** toolbar, click  **Nonlocal Couplings** and choose **Integration**.
- 2 In the **Settings** window for **Integration**, type `intop_in` in the **Operator name** text field.
- 3 Locate the **Source Selection** section. From the **Geometric entity level** list, choose **Boundary**.
- 4 Select Boundary 1 only.

Integration 2 (intop2)

- 1 In the **Definitions** toolbar, click  **Nonlocal Couplings** and choose **Integration**.
- 2 In the **Settings** window for **Integration**, type `intop_tr` in the **Operator name** text field.
- 3 Locate the **Source Selection** section. From the **Geometric entity level** list, choose **Boundary**.
- 4 Select Boundary 26 only.

Save acoustic solution on boundaries

- 1 In the **Definitions** toolbar, click  **Explicit**.
- 2 In the **Settings** window for **Explicit**, type `Save acoustic solution on boundaries` in the **Label** text field.
- 3 Locate the **Input Entities** section. From the **Geometric entity level** list, choose **Boundary**.

4 Select Boundaries 19, 26, and 53 only.

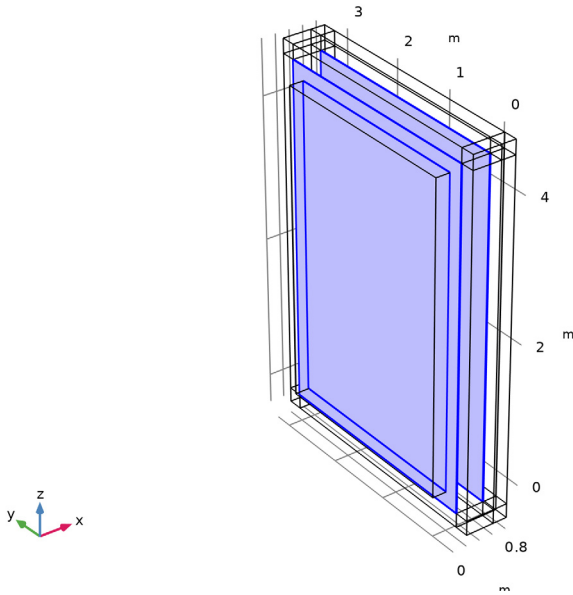

Save solid solution on boundaries

- 1 In the **Definitions** toolbar, click  **Explicit**.
- 2 In the **Settings** window for **Explicit**, type Save solid solution on boundaries in the **Label** text field.
- 3 Locate the **Input Entities** section. From the **Geometric entity level** list, choose **Boundary**.

4 Select Boundaries 1-5 and 26 only.

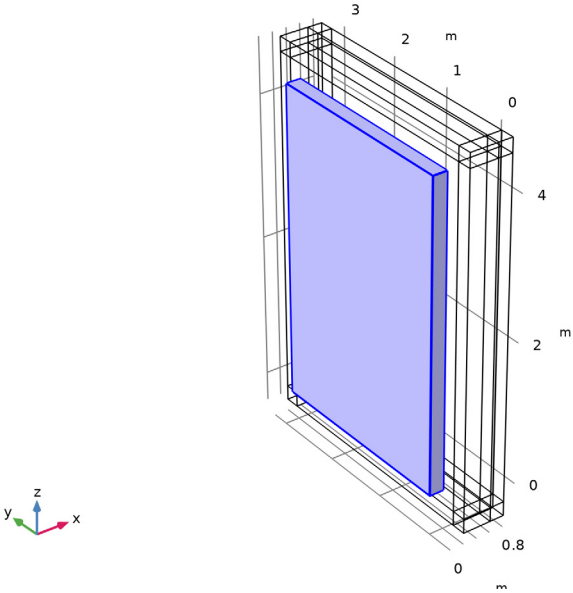

Perfectly Matched Layer 1 (pml1)

I In the **Definitions** toolbar, click  **Perfectly Matched Layer**.

2 Select Domains 2–5 and 7–19 only.

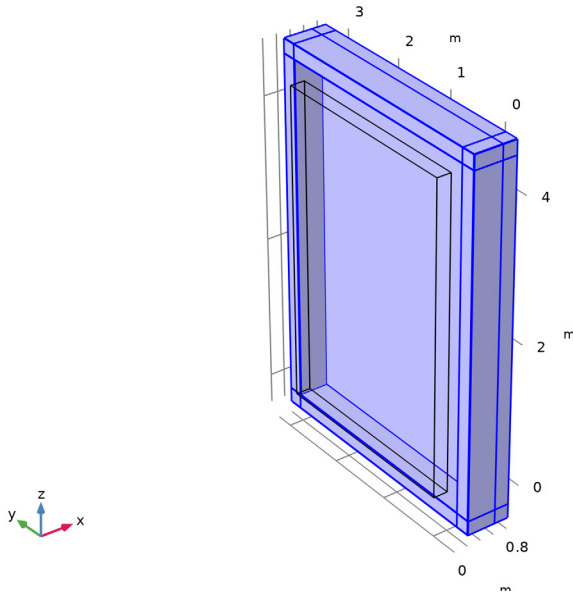

3 In the **Settings** window for **Perfectly Matched Layer**, locate the **Scaling** section.

4 In the **PML scaling curvature parameter** text field, type 3.

SOLID MECHANICS (SOLID)

Linear Elastic Material 1

In the **Model Builder** window, under **Component 1 (comp1) > Solid Mechanics (solid)** click **Linear Elastic Material 1**.

Damping 1

1 In the **Physics** toolbar, click  **Attributes** and choose **Damping**.

2 In the **Settings** window for **Damping**, locate the **Damping Settings** section.

3 From the **Damping type** list, choose **Isotropic loss factor**.

Next, return to the **Concrete** material node and add the value for the isotropic loss factor.

MATERIALS

Concrete (mat2)

1 In the **Model Builder** window, under **Component 1 (comp1) > Materials** click **Concrete (mat2)**.

- 2 In the **Settings** window for **Material**, locate the **Material Contents** section.
- 3 In the table, enter the following settings:

Property	Variable	Value	Unit	Property group
Isotropic structural loss factor	eta_s	0.01		Basic

SOLID MECHANICS (SOLID)

Fixed Constraint 1

- 1 In the **Physics** toolbar, click  **Boundaries** and choose **Fixed Constraint**.
- 2 Select Boundaries 2–5 only.

The selection should look like this.

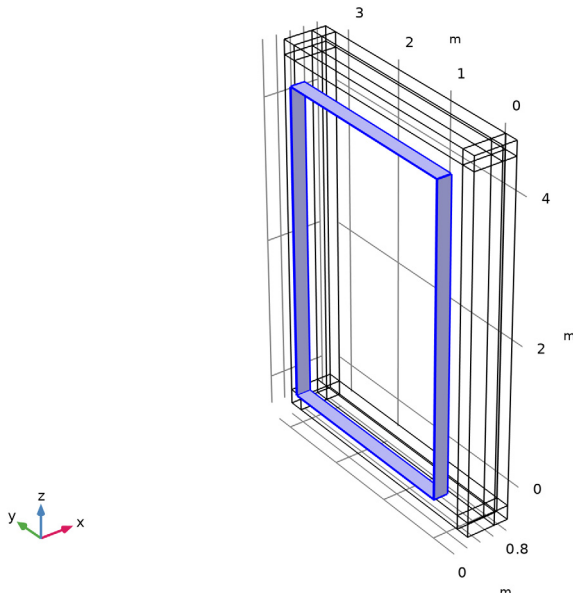

Boundary Load 1

- 1 In the **Physics** toolbar, click  **Boundaries** and choose **Boundary Load**.
- 2 Select Boundary 1 only.
- 3 In the **Settings** window for **Boundary Load**, locate the **Force** section.
- 4 From the **Load type** list, choose **Pressure**.
- 5 In the p text field, type p_{wall} .

In this model, the mesh is set up manually. Proceed by directly adding the desired mesh component. The following steps show how to create a swept mesh to reduce the computation time.

MESH I

Free Quad I

- 1 In the **Mesh** toolbar, click  **More Generators** and choose **Free Quad**.
- 2 Select Boundary 19 only.

Size

- 1 In the **Model Builder** window, click **Size**.
- 2 In the **Settings** window for **Size**, locate the **Element Size** section.
- 3 Click the **Custom** button.
- 4 Locate the **Element Size Parameters** section. In the **Maximum element size** text field, type $c0/fmax/5$.
- 5 In the **Minimum element size** text field, type $c0/fmax/6$.

Mapped I

- 1 In the **Mesh** toolbar, click  **More Generators** and choose **Mapped**.
- 2 Select Boundaries 6, 9, 12, 16, 22, 26, 27, 30, and 33 only.

Distribution I

- 1 Right-click **Mapped I** and choose **Distribution**.
- 2 Select Edges 16, 26, 35, and 39 only.
- 3 In the **Settings** window for **Distribution**, locate the **Distribution** section.
- 4 In the **Number of elements** text field, type 8.
- 5 Click  **Build All**.





Swept I

In the **Mesh** toolbar, click  **Swept**.

Distribution I

- 1 Right-click **Swept I** and choose **Distribution**.
- 2 In the **Settings** window for **Distribution**, locate the **Domain Selection** section.
- 3 Click  **Clear Selection**.
- 4 Select Domain 1 only.
- 5 Locate the **Distribution** section. In the **Number of elements** text field, type 2.

Distribution 2

- 1 In the **Model Builder** window, right-click **Swept 1** and choose **Distribution**.
- 2 In the **Settings** window for **Distribution**, locate the **Domain Selection** section.
- 3 Click  **Clear Selection**.
- 4 In the **Graphics** window toolbar, click  next to  **Select Box**, then choose **Entity Intersects**.
- 5 Select Domains 11–19 only.
- 6 Locate the **Distribution** section. In the **Number of elements** text field, type 8.
- 7 Click  **Build All**.

The mesh should look like this.

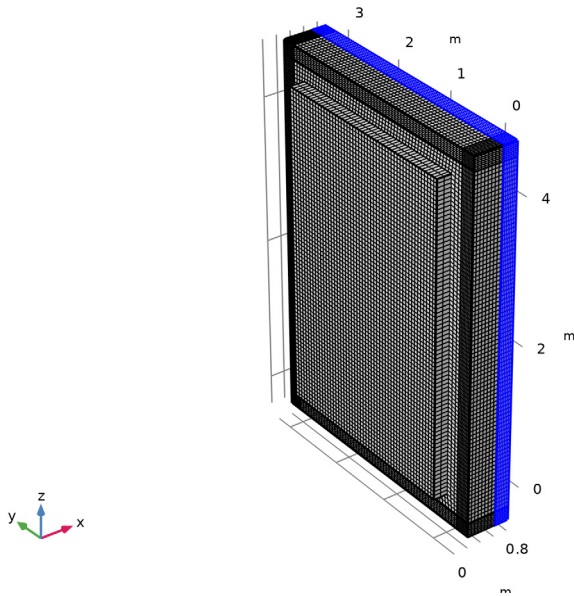

STUDY 1 - FREQUENCY ANALYSIS

- 1 In the **Model Builder** window, click **Study 1**.
- 2 In the **Settings** window for **Study**, type Study 1 - Frequency Analysis in the **Label** text field.

Solution 1 (sol1)

1 In the **Study** toolbar, click  **Show Default Solver**.

The default solver works, but to reduce the computation time, enable the second suggested iterative solver. This solver is both faster and more memory efficient than the default direct solver. It uses a multigrid preconditioner for the acoustic variables and a direct preconditioner for the solid mechanics variables.

2 In the **Model Builder** window, expand the **Solution 1 (sol1)** node.

3 In the **Model Builder** window, expand the **Study 1 - Frequency Analysis > Solver Configurations > Solution 1 (sol1) > Stationary Solver 1** node.

4 Right-click **Study 1 - Frequency Analysis > Solver Configurations > Solution 1 (sol1) > Stationary Solver 1 > Suggested Iterative Solver (GMRES with GMG and Direct Precond.) (asb1)** and choose **Enable**.

Step 1: Frequency Domain

1 In the **Model Builder** window, under **Study 1 - Frequency Analysis** click **Step 1: Frequency Domain**.

2 In the **Settings** window for **Frequency Domain**, locate the **Study Settings** section.

3 Click  **Range**.

4 In the **Range** dialog, choose **ISO preferred frequencies** from the **Entry method** list.

5 In the **Start frequency** text field, type 35.

6 In the **Stop frequency** text field, type f_{max} .

7 From the **Interval** list, choose **1/12 octave**.

8 Click **Replace**.

9 In the **Settings** window for **Frequency Domain**, click to expand the **Store in Output** section.

10 In the table, enter the following settings:

Interface	Output
Pressure Acoustics, Frequency Domain (acpr)	Selection

11 Under **Selections**, click  **Add**.

12 In the **Add** dialog, select **Save acoustic solution on boundaries** in the **Selections** list.

13 Click **OK**.

14 In the **Settings** window for **Frequency Domain**, locate the **Store in Output** section.

15 In the table, enter the following settings:

Interface	Output
Solid Mechanics (solid)	Selection

16 Under **Selections**, click **+ Add**.

17 In the **Add** dialog, select **Save solid solution on boundaries** in the **Selections** list.

18 Click **OK**.

Storing the solution only on the selected boundaries reduces the model size when saved.

19 In the **Study** toolbar, click **= Compute**.

RESULTS

Acoustic Pressure (acpr)

Inspect the default plots generated. You can change the evaluation frequency if needed. Notice that the isosurface plot is less interesting since you have only stored the solution on boundaries.

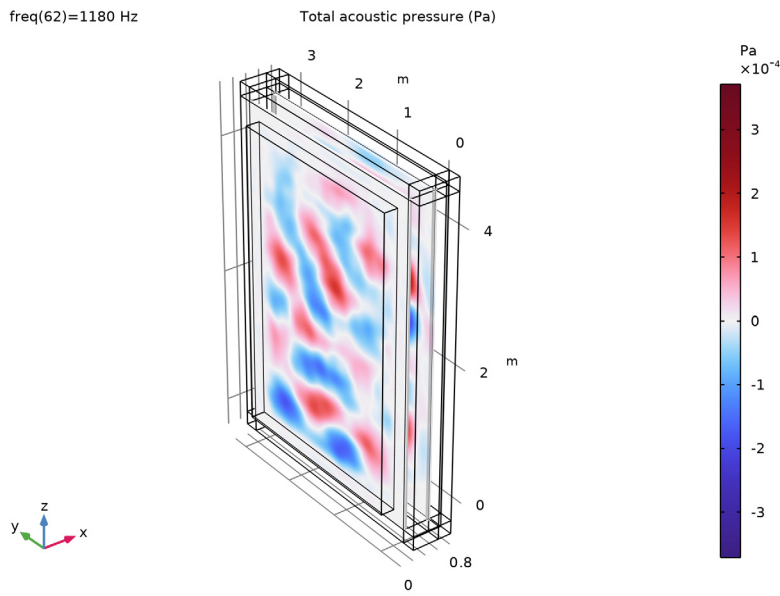

Sound Pressure Level (acpr)

In the **Model Builder** window, click **Sound Pressure Level (acpr)**.

freq(62)=1180 Hz

Total sound pressure level (dB)

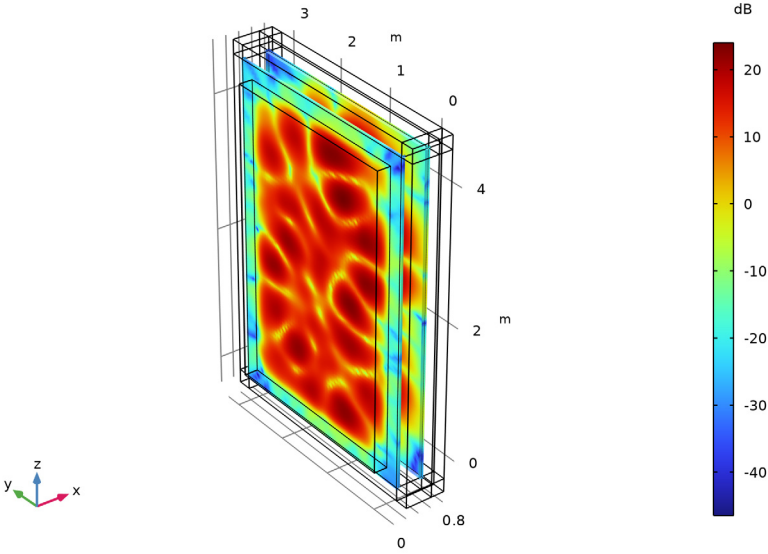

Acoustic Pressure, Isosurfaces (acpr)

- 1 In the **Model Builder** window, click **Acoustic Pressure, Isosurfaces (acpr)**.

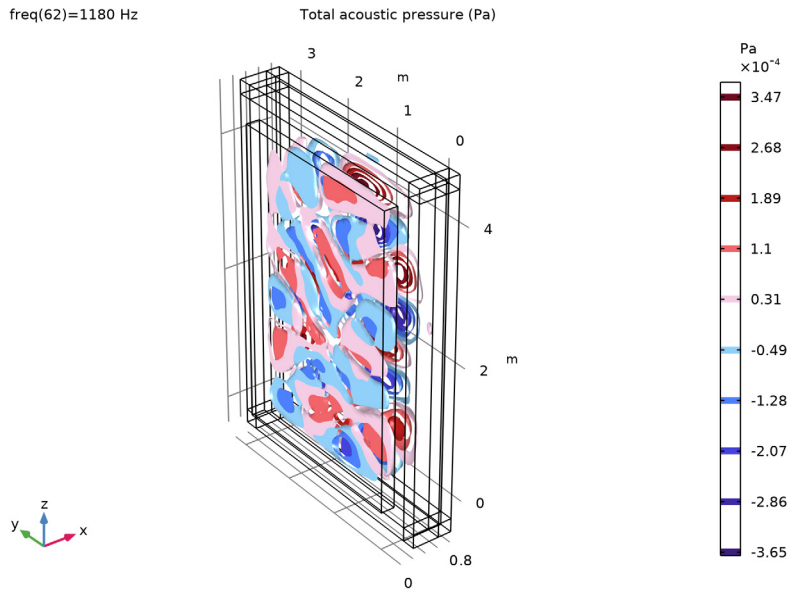

- 2 In the **Model Builder** window, click **Results**.
- 3 In the **Settings** window for **Results**, locate the **Update of Results** section.
- 4 Select the **Only plot when requested** checkbox.

Stress (solid)

- 1 In the **Model Builder** window, click **Stress (solid)**.
- 2 In the **Settings** window for **3D Plot Group**, locate the **Color Legend** section.
- 3 Select the **Show units** checkbox.

Volume 1

- 1 In the **Model Builder** window, expand the **Stress (solid)** node, then click **Volume 1**.
- 2 In the **Settings** window for **Volume**, locate the **Coloring and Style** section.
- 3 From the **Scale** list, choose **Linear**.

Deformation

- 1 In the **Model Builder** window, expand the **Volume 1** node.
- 2 Right-click **Deformation** and choose **Delete**.

Volume 1

In the **Stress (solid)** toolbar, click  **Plot**.

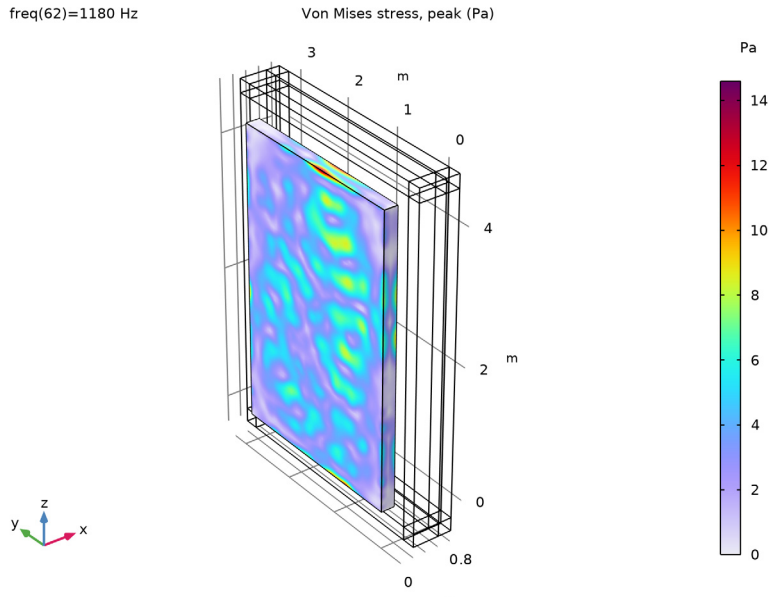

Next, create plots of the incident and transmitted intensity, the displacement, as well as 1D plots of the STL.

Incident Intensity

- 1 In the **Results** toolbar, click  **3D Plot Group**.
- 2 In the **Settings** window for **3D Plot Group**, type Incident Intensity in the **Label** text field.
- 3 Locate the **Color Legend** section. Select the **Show units** checkbox.

Surface 1

- 1 Right-click **Incident Intensity** and choose **Surface**.
- 2 In the **Settings** window for **Surface**, locate the **Expression** section.
- 3 In the **Expression** text field, type I_{x_room} .
- 4 Locate the **Coloring and Style** section. From the **Color table** list, choose **Rainbow**.
- 5 From the **Scale** list, choose **Linear**.

Selection 1

- 1 Right-click **Surface 1** and choose **Selection**.

- 2 Select Boundary 1 only.
- 3 In the **Incident Intensity** toolbar, click  **Plot**.
The plot is depicted at four frequencies in [Figure 4](#).



Transmitted Intensity

- 1 In the **Model Builder** window, right-click **Incident Intensity** and choose **Duplicate**.
- 2 In the **Settings** window for **3D Plot Group**, type Transmitted Intensity in the **Label** text field.



Surface 1

- 1 In the **Model Builder** window, expand the **Transmitted Intensity** node, then click **Surface 1**.
- 2 In the **Settings** window for **Surface**, locate the **Expression** section.
- 3 In the **Expression** text field, type $\text{acpr} \cdot I_x$.

Selection 1

- 1 In the **Model Builder** window, expand the **Surface 1** node, then click **Selection 1**.
- 2 In the **Settings** window for **Selection**, locate the **Selection** section.
- 3 Click to select the  **Activate Selection** toggle button.
- 4 Select Boundary 26 only.
- 5 In the **Transmitted Intensity** toolbar, click  **Plot**.
The plot is depicted at four frequencies in [Figure 5](#).

RESULT TEMPLATES

- 1 In the **Results** toolbar, click  **Result Templates** to open the **Result Templates** window.
- 2 Go to the **Result Templates** window.
- 3 In the tree, select **Study 1 - Frequency Analysis/Solution 1 (sol1) > Solid Mechanics > Displacement (solid)**.
- 4 Click the **Add Result Template** button in the window toolbar.
- 5 In the **Results** toolbar, click  **Result Templates** to close the **Result Templates** window.

RESULTS

Displacement (solid)

- 1 In the **Settings** window for **3D Plot Group**, click to expand the **Title** section.
- 2 From the **Title type** list, choose **Manual**.
- 3 In the **Title** text area, type $f = \text{eval}(\text{freq}) \text{ Hz}$.

- 4 Locate the **Plot Settings** section. Clear the **Plot dataset edges** checkbox.
- 5 Locate the **Color Legend** section. Select the **Show units** checkbox.

Volume 1

- 1 In the **Model Builder** window, expand the **Displacement (solid)** node.
- 2 Right-click **Volume 1** and choose **Delete**.

Surface 1

- 1 Right-click **Displacement (solid)** and choose **Surface**.
- 2 In the **Settings** window for **Surface**, locate the **Expression** section.
- 3 In the **Expression** text field, type `solid.disp`.
- 4 Locate the **Coloring and Style** section. From the **Color table** list, choose **SpectrumLight**.
- 5 From the **Scale** list, choose **Linear**.

Deformation 1

Right-click **Surface 1** and choose **Deformation**.

Filter 1

- 1 In the **Model Builder** window, right-click **Surface 1** and choose **Filter**.
- 2 In the **Settings** window for **Filter**, locate the **Element Selection** section.
- 3 In the **Logical expression for inclusion** text field, type `z>1.5[m]`.

Surface 2

In the **Model Builder** window, right-click **Displacement (solid)** and choose **Surface**.

Selection 1

- 1 In the **Model Builder** window, right-click **Surface 2** and choose **Selection**.
- 2 Select Boundary 53 only.
- 3 In the **Displacement (solid)** toolbar, click  **Plot**.

The plot is depicted at four frequencies in [Figure 6](#).

Postprocessing the STL variables is time consuming, so in order to save time setting up the next three plots (avoiding automatic plotting when formatting the plots), enable the **Only plot when requested** option.

STL: P_in/P_tr (octaves)

- 1 In the **Results** toolbar, click  **ID Plot Group**.
- 2 In the **Settings** window for **ID Plot Group**, type `STL: P_in/P_tr (octaves)` in the **Label** text field.

- 3 Click to expand the **Title** section. From the **Title type** list, choose **Manual**.
- 4 In the **Title** text area, type Sound Transmission Loss (octaves).
- 5 Locate the **Plot Settings** section.
- 6 Select the **x-axis label** checkbox. In the associated text field, type f (Hz).
- 7 Select the **y-axis label** checkbox. In the associated text field, type STL (dB).
- 8 Locate the **Legend** section. From the **Position** list, choose **Lower left**.

Octave Band 1

- 1 In the **STL: P_in/P_tr (octaves)** toolbar, click  **More Plots** and choose **Octave Band**.
- 2 In the **Settings** window for **Octave Band**, locate the **Selection** section.
- 3 From the **Geometric entity level** list, choose **Global**.
- 4 Locate the **y-Axis Data** section. From the **Expression type** list, choose **Power**.
- 5 In the **Expression** text field, type P_in.
- 6 In the **Power reference** text field, type P_tr.
- 7 Locate the **Plot** section. From the **Quantity** list, choose **Continuous power spectral density**.

Octave Band 2

- 1 Right-click **Octave Band 1** and choose **Duplicate**.
- 2 In the **Settings** window for **Octave Band**, locate the **Plot** section.
- 3 From the **Quantity** list, choose **Band average power spectral density**.
- 4 Click to expand the **Coloring and Style** section. From the **Type** list, choose **Outline**.

Global 1

- 1 In the **Model Builder** window, right-click **STL: P_in/P_tr (octaves)** and choose **Global**.
- 2 In the **Settings** window for **Global**, locate the **Data** section.
- 3 From the **Dataset** list, choose **Study 1 - Frequency Analysis/Solution 1 (sol1)**.
- 4 From the **Parameter selection (freq)** list, choose **From list**.
- 5 From the **Parameter values** list select the frequencies from 100 Hz to 1180 Hz, where the measurements are valid.
- 6 Locate the **y-Axis Data** section. In the table, enter the following settings:

Expression	Unit	Description
STL_typical(freq)		Typical Measurements

7 In the **STL: P_in/P_tr (octaves)** toolbar, click  **Plot**.

The STL plot, with the octave evaluation, is depicted in [Figure 8](#).

STL: P_in/P_tr (1/3 octaves)

- 1 Right-click **STL: P_in/P_tr (octaves)** and choose **Duplicate**.
- 2 In the **Settings** window for **ID Plot Group**, type **STL: P_in/P_tr (1/3 octaves)** in the **Label** text field.
- 3 Locate the **Title** section. In the **Title** text area, type **Sound Transmission Loss (1/3 octaves)**.

Octave Band 2

- 1 In the **Model Builder** window, expand the **STL: P_in/P_tr (1/3 octaves)** node, then click **Octave Band 2**.
- 2 In the **Settings** window for **Octave Band**, locate the **Plot** section.
- 3 From the **Band type** list, choose **1/3 octave**.

Global 2

- 1 In the **Model Builder** window, right-click **STL: P_in/P_tr (1/3 octaves)** and choose **Global**.
- 2 In the **Settings** window for **Global**, locate the **Data** section.
- 3 From the **Dataset** list, choose **Study 1 - Frequency Analysis/Solution 1 (sol1)**.
- 4 From the **Parameter selection (freq)** list, choose **From list**.
- 5 From the **Parameter values** list select the frequencies from 180 Hz to 1180 Hz, to plot Sharp's equation here.
- 6 Locate the **y-Axis Data** section. In the table, enter the following settings:

Expression	Unit	Description
$10 \cdot \log_{10}(1 + (\pi \cdot \text{freq} \cdot m / (\rho \cdot c_0))^2) - 5.5$		Sharp's Equation (mass law)

7 In the **STL: P_in/P_tr (1/3 octaves)** toolbar, click  **Plot**.

The STL plot, with the 1/3 octave evaluation and Sharp's equation, is depicted in [Figure 9](#).

Incident Power (three methods)

- 1 In the **Results** toolbar, click  **ID Plot Group**.
- 2 In the **Settings** window for **ID Plot Group**, type **Incident Power (three methods)** in the **Label** text field.

- 3 Click to collapse the **Title** section. Click to expand the **Title** section. From the **Title type** list, choose **Manual**.
- 4 In the **Title** text area, type Incident Power: Three Computation Methods.
- 5 Locate the **Plot Settings** section.
- 6 Select the **x-axis label** checkbox. In the associated text field, type f (Hz).
- 7 Select the **y-axis label** checkbox. In the associated text field, type Power: P_{in} (W).
- 8 Locate the **Axis** section. Select the **x-axis log scale** checkbox.
- 9 Select the **y-axis log scale** checkbox.
- 10 Locate the **Legend** section. From the **Position** list, choose **Lower right**.

Global 1

- 1 Right-click **Incident Power (three methods)** and choose **Global**.
- 2 In the **Settings** window for **Global**, locate the **y-Axis Data** section.
- 3 In the table, enter the following settings:

Expression	Unit	Description
P_{in}	W	Incident power on the concrete surface
P_{in_proom}	W	Incident power (room pressure)
P_{in_th}	W	Theoretical incident power (limit $N \rightarrow \infty$)

- 4 In the **Incident Power (three methods)** toolbar, click  **Plot**.
The power plot is depicted in [Figure 10](#).

Proceed to add a second study to perform an eigenfrequency analysis of the structure (the wall). When adding the study, clear the Pressure Acoustics interface and the multiphysics coupling. In the analysis setup look for the first three modes.

ADD STUDY

- 1 In the **Home** toolbar, click  **Add Study** to open the **Add Study** window.
- 2 Go to the **Add Study** window.
- 3 Find the **Studies** subsection. In the **Select Study** tree, select **General Studies > Eigenfrequency**.
- 4 Find the **Physics interfaces in study** subsection. In the table, clear the **Solve** checkbox for **Pressure Acoustics, Frequency Domain (acpr)**.
- 5 Find the **Multiphysics couplings in study** subsection. In the table, clear the **Solve** checkbox for **Acoustic–Structure Boundary 1 (asb1)**.

- 6 Click the **Add Study** button in the window toolbar.
- 7 In the **Home** toolbar, click  **Add Study** to close the **Add Study** window.

STUDY 2 - EIGENFREQUENCY ANALYSIS

In the **Settings** window for **Study**, type Study 2 - Eigenfrequency Analysis in the **Label** text field.

Step 1: Eigenfrequency

- 1 In the **Model Builder** window, under **Study 2 - Eigenfrequency Analysis** click **Step 1: Eigenfrequency**.
- 2 In the **Settings** window for **Eigenfrequency**, locate the **Study Settings** section.
- 3 Select the **Desired number of eigenfrequencies** checkbox. In the associated text field, type 3.
- 4 From the **Search method around shift** list, choose **Larger real part**.
- 5 In the **Study** toolbar, click  **Compute**.

RESULTS

Surface 1

- 1 In the **Model Builder** window, expand the **Mode Shape (solid)** node, then click **Surface 1**.
- 2 In the **Settings** window for **Surface**, locate the **Coloring and Style** section.
- 3 From the **Scale** list, choose **Linear**.

The first three structural modes are depicted in [Figure 7](#). A table with the eigenvalues is also automatically generated. To see the table select the **Eigenfrequencies (Study 2)** evaluation group node.

- 4 In the **Model Builder** window, click **Results**.
- 5 In the **Settings** window for **Results**, locate the **Save Data in the Model** section.
- 6 From the **Save plot data** list, choose **On** to avoid rerendering the STL curves when the model is opened again.