



Model created in COMSOL Multiphysics 6.4

# Small Concert Hall Acoustics

## Introduction

---

Designing structures and open spaces with respect to sound quality is important for concert halls, outdoor environments, and even the rooms of a house. Simulating acoustics in the high-frequency limit, where the wavelength is smaller than the geometrical features, is best done with ray acoustics.

This tutorial model shows the basic steps and principles used when setting up a model using the *Ray Acoustics* physics interface. In the model, the acoustics of a small concert hall is analyzed. The model setup includes an omnidirectional sound source, a directional loudspeaker, wall boundary conditions for specular and diffuse scattering, surface sound pressure level evaluation, analyzing the impulse response, evaluation of objective room acoustic metrics, and a reflectogram. The metric results are compared to simple analytical estimates.

## Model Definition

---

In this model the acoustics of a generic small concert hall is analyzed. Its geometry is depicted in [Figure 1](#). It is a fan-shaped hall with a volume of  $460 \text{ m}^3$  and a total surface area of  $390 \text{ m}^2$ , fitted with absorbers and diffusers. The location of the different materials is not particularly optimized and does not necessarily follow design rules. Rather than accuracy, the aim of this tutorial is to describe the important modeling steps to perform a room acoustics simulation using ray tracing. The back wall of the room consists of windows and reflective surfaces only, with all the absorption and diffusion being located on the side walls. The stage lies  $0.5 \text{ m}$  above the ground. The seating area is modeled as a box extruding  $1 \text{ m}$  high from the ground. It is common practice in ray acoustics to simplify geometry details, and seating is typically represented as a box with equivalent absorption and scattering.

In order to derive the room acoustic metrics, an omnidirectional source is located at the coordinates  $(x_{\text{src}}, y_{\text{src}}, z_{\text{src}})$  at the front of the stage. It generates a pulse that has an SPL of  $100 \text{ dB}$  at  $1 \text{ m}$  from the source. The receiver (microphone) is located at the coordinates  $(x_{\text{rec}}, y_{\text{rec}}, z_{\text{rec}})$ . These are parameters found under **Global Definitions > Parameters**. The locations of the source and receiver need to be set before running the model. It is also possible, however, to add new receivers in postprocessing. While this avoids having to run the model again, it adds a significant amount of evaluation time to the plots. The size of the receiver is set to match the common width of a seat, with a receiver radius  $r = 0.3 \text{ m}$ . This value is entered to create a sphere in the geometry, which is then used as input in the **Receiver** feature under the *Ray Acoustics* physics interface. The number of rays emitted by the source is then determined to limit the error in the calculated impulse response. For an

expected error of 1 dB in every time interval  $\Delta t$  of the response, the number of rays should be (see Ref. 1)

$$N_{\text{rays}} = 4.34^2 \frac{V}{\pi r^2 c \Delta t} \quad (1)$$

With  $\Delta t = 0.01$  s, the resulting value gives  $N_{\text{rays}} = 9000$  after rounding up. Determining the number of rays from the volume of the room and the receiver size is a favorable option as default and when there are multiple receivers in the space. If the receiver is defined in postprocessing, it is also possible to set a desired number of rays and use the predefined expression to calculate the size of the receiver according to the volume of the room, the distance to the source, and the number of rays. This corresponds to the **Radius input** option **Variable size (large room volume)** on the **Receiver 3D** dataset with the **Receiver** option set to **Local**. This option can be an interesting approach in the case of a single receiver. A directional loudspeaker is also included at the coordinates  $(x_{\text{spk}}, y_{\text{spk}}, z_{\text{spk}})$ . It is used in a separate study where the sound pressure level in the hall is investigated.

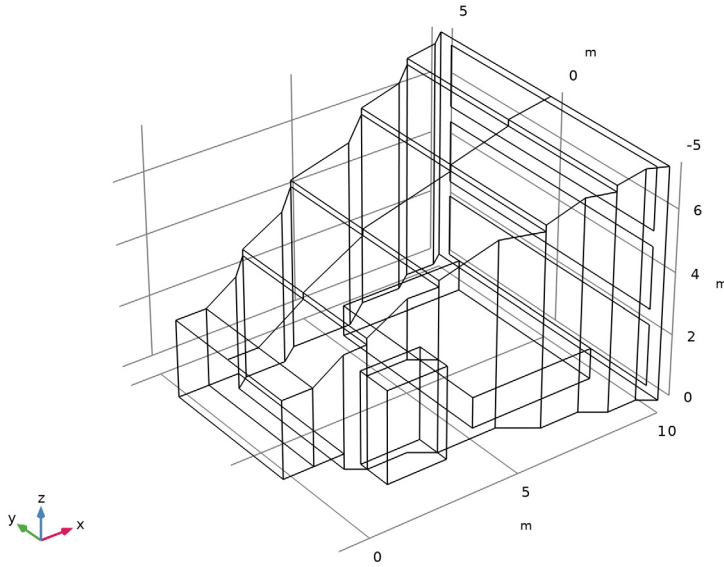

*Figure 1: Geometry of the small concert hall.*

The absorption properties of the various surfaces (floor, walls, windows, seating, entrance, absorbers, and diffusers) are values taken from Ref. 1–3. The windows are taken as large panes of heavy glass, and the seating area is considered unoccupied. The data is given in octave bands and imported from the file

small\_concert\_hall\_absorption\_parameters.txt into an interpolation function (lookup table). The scattering coefficients of the diffusers and seating areas are also taken from Ref. 3. For seemingly flat surfaces, a default scattering coefficient  $s = 0.05$  is defined to account for the roughness of the materials. Moreover, the amplitude attenuation of air at 20°C and 50% humidity is imported from the file small\_concert\_hall\_air\_attenuation.txt. The imported parameter  $a_{\text{air}}$  can be entered directly in the **Material Properties of Exterior and Unmeshed Domains** section, as an amplitude attenuation  $\alpha_{\text{ext}} = a_{\text{air}}(f_0)$ .

## *Results and Discussion*

---

The first study allows to derive the room impulse response and the objective quality metrics by activating only the omnidirectional source. The local wavefront sound pressure level (SPL) is depicted in Figure 2 after 10 ms and in Figure 3 after 20 ms propagation for the 8 kHz frequency band. This type of plot can be used to inspect holes in the geometry and potential standing wave patterns. Creating an animated version is easily done and can help the visual inspection. When the **Compute intensity** option is selected in the *Ray Acoustics* interface, wavefront curvature, intensity, and SPL is calculated along each ray. They allow visualization of the (spatially) local acoustic properties. However, it is the acoustic power transported by each ray that is important when calculating the impulse response (IR) and when visualizing the sound pressure level at surfaces. This means that the **Compute power** option should always be selected for IR computation, while the **Compute intensity** can be turned off. Only selecting **Compute power** will also reduce the number of degrees of freedom (DOFs) solved for, making the model run faster and the size of the saved file smaller. The **Count reflections** option is also necessary when analyzing the IR.



The temporal impulse response (IR) for the source and receiver configuration used in the model is depicted in [Figure 4](#). The frequency domain (FFT) of the IR is depicted in [Figure 5](#). The curve is smoothed with a 1/3-octave running average.

When an IR is reconstructed from a ray tracing simulation, information is inferred and put back into the time signal using the temporal filter kernels. The quality of the simulated IR increases with the number of rays as well as the frequency resolution of the absorption, scattering, and source data (this data can be difficult to get from vendors but can often be simulated). In this model, octave band resolution is used. The Impulse Response plot also allows the use of 1/3-octave and 1/6-octave frequency resolution.

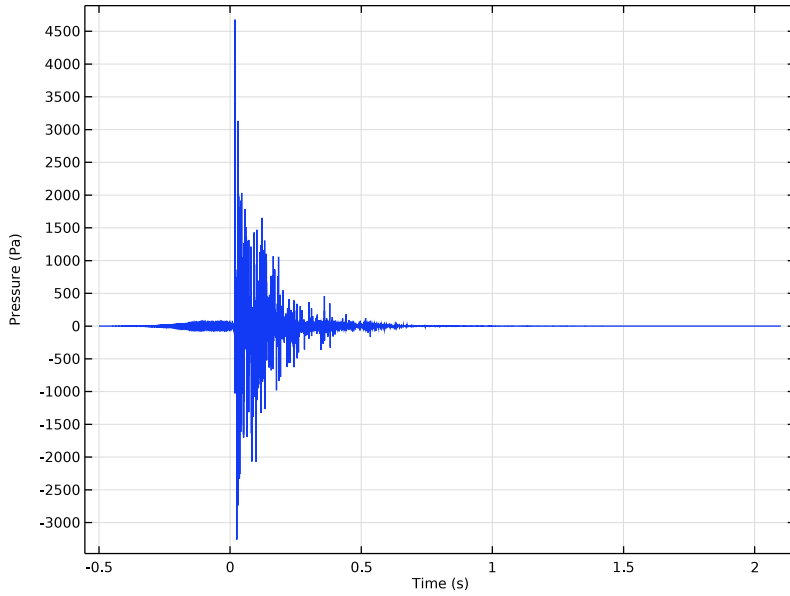

Figure 4: Room impulse response computed at the receiver location.

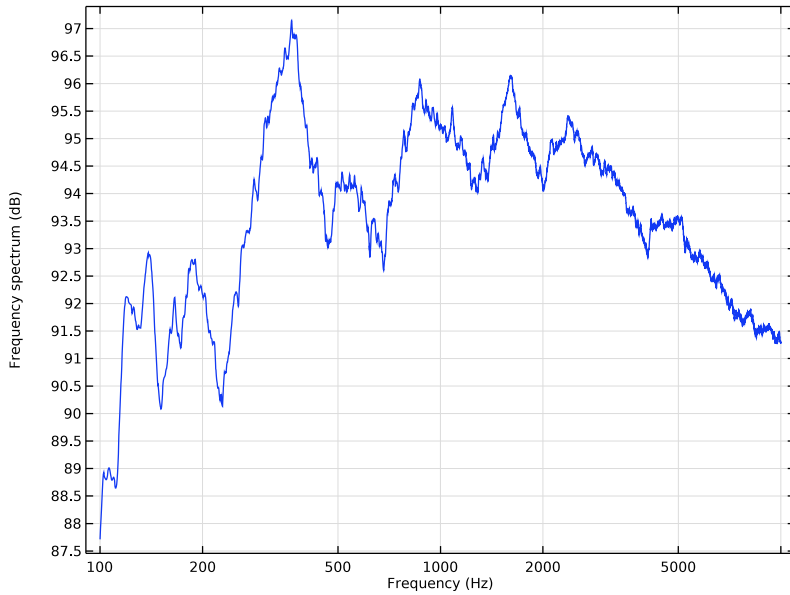
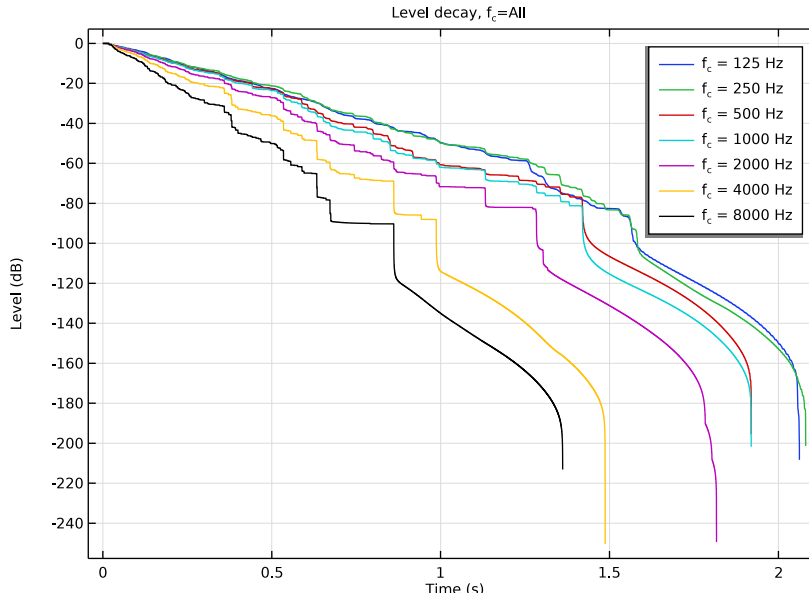

Figure 5: FFT of the room impulse response (1/3-octave running average).

The IR is further analyzed using the **Energy Decay** subfeature to the **Impulse Response** plot. The subfeature enables the computation of the objective room acoustic metrics like clarity  $C_{80}$ ; definition  $D$ ; early decay time EDT; center time  $t_s$ ; reverberation times  $T_{20}$ ,  $T_{30}$ , and  $T_{60}$ ; and speech transmission index STI. The level decay curves for the seven octave bands used in the model (computed by the **Energy Decay** subfeature) are depicted in [Figure 6](#). The metrics can be found in the **Objective Quality Metrics** table in the model (**Results > Tables**). The values are depicted graphically in [Figure 9](#) and [Figure 10](#).

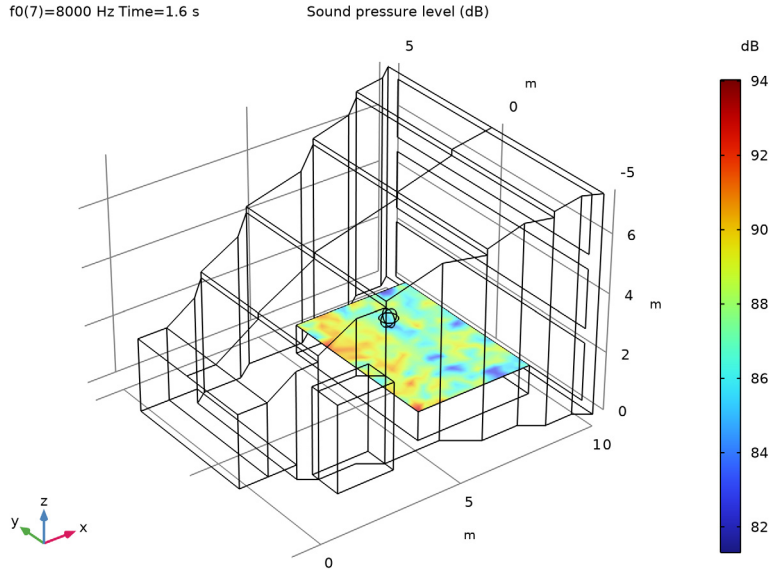

*Figure 6: Level decay curves for the 7 octave bands used in the model.*

In order to obtain accurate room acoustic metrics, it is important to ensure the quality of the level decay curves from which they are calculated. The first indicator for quality is the smoothness of the curves. If there are flat sections followed by sudden large drops in level, the number of rays in the simulation should be increased. The default value given in [Equation 1](#) should be sufficient for this in the majority of cases. The second aspect to look at is the amplitude of level decay before the termination point where the curves fade out and become vertical. There should indeed be a large enough decay to fit the definitions of the different room acoustic metrics (for example,  $T_{60}$  takes into account the decay from  $-5$  dB to  $-65$  dB). A general guideline for this to be true is to set the impulse response duration approximately equal to or larger than the reverberation time. This is done in **Study 1 > Step 1: Ray Tracing > Output times**, where the entered values should be 0 and the end time of the simulation. The other parameter controlling the decay amplitude is the

energy threshold at which rays are terminated. This threshold should be sufficiently low to avoid losing valuable information. Its value is found in **Component 1 > Ray Acoustics > Ray Termination 1**, where the default recommendation is to use **Power** as **Additional termination criteria** and a threshold equal to the initial power of individual rays multiplied by  $10^{-7}$ . This expression ensures a consistent termination criterion according to the source power and number of rays in the simulation, with the factor  $10^{-7}$  allowing a large enough decay in most cases.

The sound pressure level on the seating area is depicted in [Figure 7](#) for the 8 kHz band. It is calculated using the **Sound Pressure Level Calculation** feature, available as a subnode to all **Wall** boundary conditions. In this case it is added to the top surface of the box representing the seating area. The feature can be added to all other walls to postprocess the SPL distribution if necessary.



*Figure 7: SPL from the omnidirectional source at the location of the audience.*

In the ray tracing method, the intensity  $I$  and RMS pressure  $p_{\text{rms}}$  of the  $n^{\text{th}}$  ray detected by the receiver sphere is expressed as

$$I_n = \frac{L_r Q_n}{V_r} \quad (p_{\text{rms}})_n = \rho c I_n$$

where  $V_r$  is the receiver volume,  $L_r$  is the distance traveled by the ray inside the receiver, and  $Q_n$  is the power carried by the ray (see Ref. 4). The intensity is evaluated using the expression  $\text{re1dist} * \text{rac.Q/re1vol}$ . Plotting this information in a **Ray** plot as a function of the arrival time yields the (discrete time) energy impulse response, or reflectogram. It is plotted for the 125 Hz and the 8 kHz octave bands in Figure 8. The slope of the curves (point data) gives a visual indication of the reverberation time of the room. In Figure 8 approximate trend lines have been added manually; their slope (from  $-5$  dB to  $-65$  dB which is six decades for  $\log_{10}(I_n)$ ) gives an estimate of the  $T_{60}$  reverberation time. In this case about 0.5 s for the 8 kHz band and 1.15 s for the 125 Hz band. These values are seen to fit well with the computed values below.

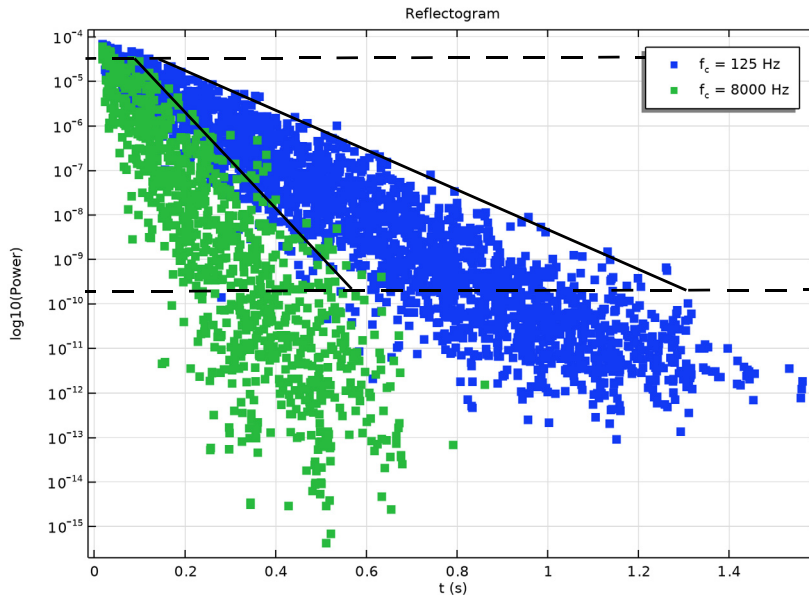

Figure 8: The raw data of the energetic impulse response or reflectogram. The slope represents the reverberation time in the given octave band.

A comparison between the computed value of reverberation time and simple statistical estimates is shown in Figure 9. To plot the data from the results table the **Table Graph** plot is used. The estimated values are calculated using the Sabine and Eyring equations used in statistical room acoustics

$$T_{60,S} = 0.161 \text{ s/m} \frac{V}{S\bar{\alpha} + 8a_{\text{air}}V}$$

$$T_{60,E} = 0.161 \text{ s/m} \frac{V}{-S\ln(1-\bar{\alpha}) + 8a_{\text{air}}V}$$

where  $V$  is the room volume,  $S$  is the total surface area,  $a_{\text{air}}$  is the atmospheric amplitude attenuation, and  $\bar{\alpha}$  is the average wall absorption (see Ref. 2). The results show a good agreement in this case. However, it is not expected that the Sabine and Eyring predictions always match simulation results closely, especially in rooms where the diffuse sound field assumption does not hold.

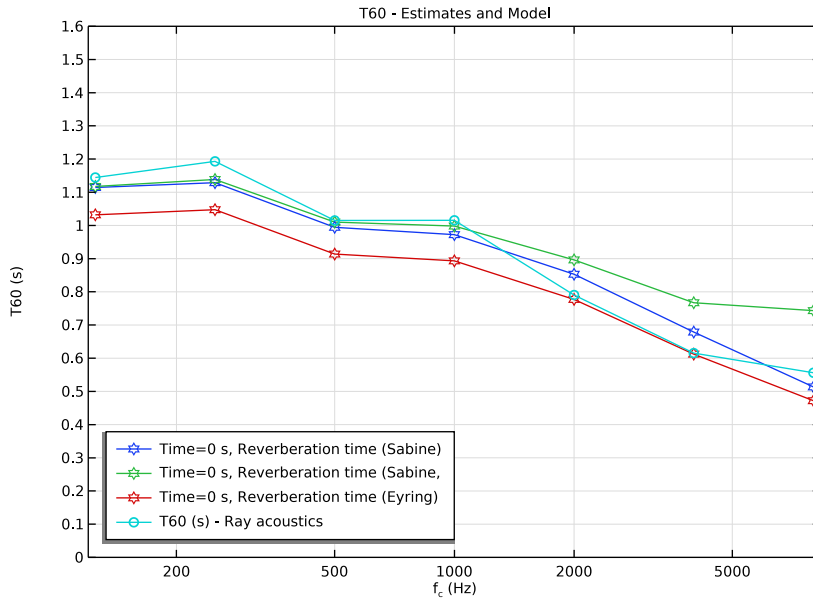

Figure 9: Reverberation time estimates based on the Sabine and Eyring formulas compared to the computed reverberation time.

Selected room acoustic metrics are plotted as functions of the octave band center frequency in Figure 10. The definition and clarity metrics are also compared to analytical estimates in the figures. The estimates are based on analytical models of the direct energy, early energy, and late energy (see Ref. 1). They are defined in the **Definitions > Variables: Quality Metric Estimates**. All metrics should be estimated taking their just noticeable difference (JND) into account when investigating a study case.

Definition D (or  $D_{50}$ ) gives a metric for syllable intelligibility. In this room it is around 40% to 50% for most bands which is acceptable for a space with a purpose focused on

music. The center time  $t_g$  is another metric that correlates to speech intelligibility, it is not shown here but can be found in the model. The clarity metric  $C_{80}$  is used to characterize the transparency of music, for concert halls typical values lie between  $-5$  dB to  $+3$  dB. In this case the design is not optimal for the higher octave bands.

Several definitions of the reverberation time exist, each using a different decay range to quantify the reverberance of a room, or in other words the rate at which acoustic energy is dissipated. In this case the four variables EDT,  $T_{20}$ ,  $T_{30}$ , and  $T_{60}$  return similar values; this indicates that the room exhibits a rather steady decay over time, a sign that the sound field is close to diffuse conditions.

The speech transmission index STI is a single valued metric for speech intelligibility. It is based on modulation transfer function values (14 frequencies) and seven octave bands. The **Modulation transfer function** can be plotted using the **Energy Decay** subfeature. The STI is computed as a single value that combines the information in the seven bands. To get the single metric, change the **Band type** to **Broadband** in the **Energy Decay** plot. Making these changes gives an STI value of 0.61 (this indicates good intelligibility). The STI values plotted as a function of octave band center frequency in [Figure 10](#) are computed based on

the apparent signal to noise ratio in each band. When **Broadband** is selected the values in the different bands contribute with the appropriate weighting.

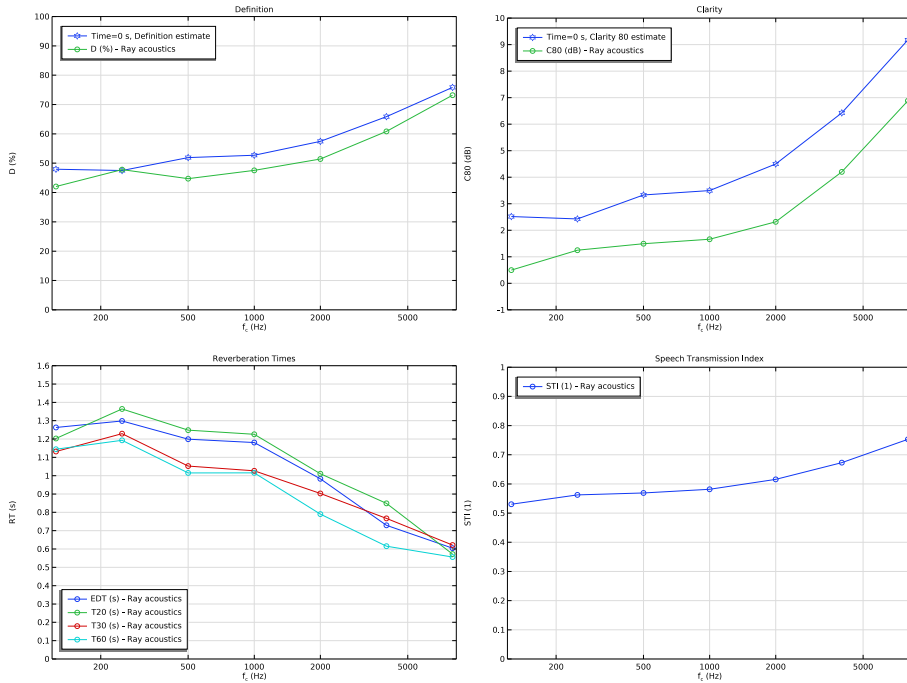

Figure 10: Objective room acoustic metrics clarity, definition, reverberation times, and speech transmission index plotted as functions of octave band center frequency. The clarity and definition metrics are compared to analytical estimates. The center time can be seen in the step-by-step instructions and in the model.

The second study investigates the sound field resulting from the directional loudspeaker. Its orientation is defined with a rotated coordinate system as depicted in Figure 11. It was set to point toward the audience area in this example. The directivity of the loudspeaker is also shown in Figure 12 with the SPL of the rays at 4 kHz after 1 ms.

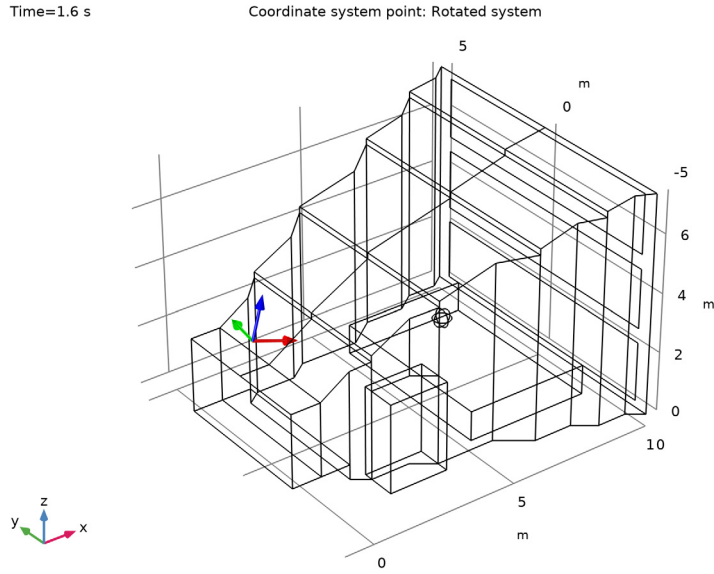

Figure 11: Orientation of the directional loudspeaker.

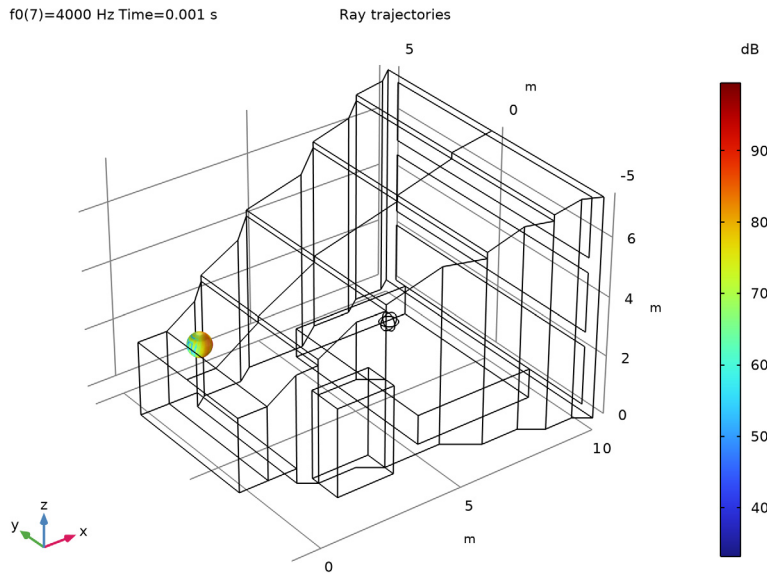
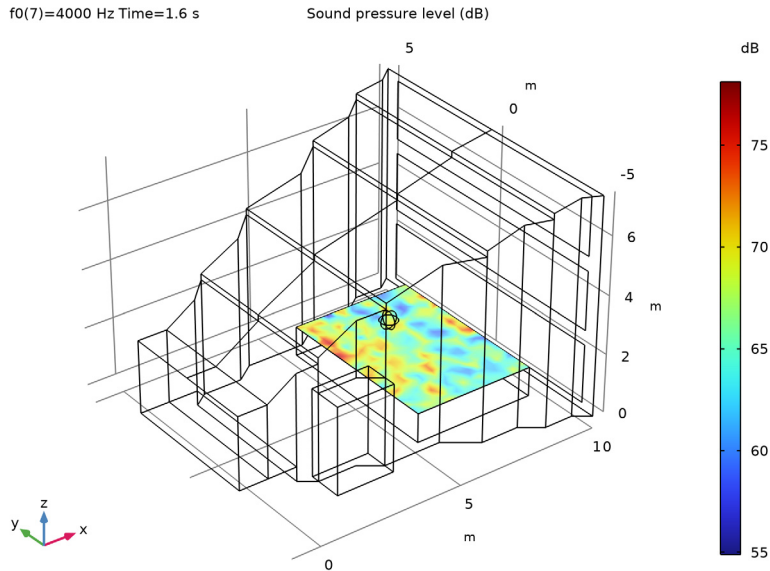

Figure 12: Ray location and SPL after 1 ms with the directional loudspeaker.

The SPL on the top surface of the seats is now considered. As seen in [Figure 13](#), the highest levels are found at the front seats on the side of the loudspeaker and at the back seats thanks to the close wall reflection. A different loudspeaker location or a combination of several loudspeakers should therefore be investigated if the target was to uniformly cover the audience area.



*Figure 13: SPL from the directional loudspeaker at the location of the audience.*

### *Notes About the COMSOL Implementation*

Receivers can be set up in two different ways in *Ray Acoustics*. The first method is to add receivers in the physics node as was done in this model. It requires geometry objects with fixed positions, but it allows to gather the data needed for impulse response calculation while solving the model. This saves a large amount of evaluation time when postprocessing the results without noticeably extending the solution time. It is therefore the recommended method. The second method is to define local receivers directly in the dataset. The advantage of this method is the flexibility of the receiver position. Indeed, new receivers can be added or existing ones can be modified to analyze new impulse responses without having to solve the model again. However, the prohibitively long evaluation time related to this option makes it suitable only in some specific cases.

The radiation directivity used in the second study was calculated and imported from a separate loudspeaker model. See the [Loudspeaker Driver in a Vented Enclosure](#) model in the *Acoustics Module Application Library* to learn how to create and export such data.

The size of the saved file can be greatly reduced by activating the **Only store receiver data and accumulated variables** option in the *Ray Acoustics* interface node. By doing so, however, some information along the ray will be lost. As a consequence, results evaluating the **Ray** dataset directly, such as the **Ray Trajectories** plot, cannot be calculated correctly. See the [Chamber Music Hall](#) model in the *Acoustics Module Application Library* for details on how to use this option and investigate all the different results accordingly.

## References

---

1. M. Vorländer, *Auralization, Fundamentals of Acoustics, Modeling, Simulation, Algorithms and Acoustic Virtual Reality*, Springer, 2008.
2. H. Kuttruff, *Room Acoustics*, CRC Press, 2009.
3. T.J. Cox and P. D’Antonio, *Acoustic Absorbers and Diffusers: Theory, design and application*, Taylor & Francis, 2009.
4. Z. Xiangyang, C. Ke’an, and S. Jincai, “On the accuracy of the ray-tracing algorithms based on various sound receiver models,” *Appl. Acoust.*, vol. 64, pp. 433–441, 2003.

---

**Application Library path:** Acoustics\_Module/Building\_and\_Room\_Acoustics/  
small\_concert\_hall

---

## Modeling Instructions

---

From the **File** menu, choose **New**.

### NEW

In the **New** window, click  **Model Wizard**.



### MODEL WIZARD

- 1 In the **Model Wizard** window, click  **3D**.
- 2 In the **Select Physics** tree, select **Acoustics > Geometrical Acoustics > Ray Acoustics (rac)**.
- 3 Click **Add**.

- 4 Click  **Study**.
- 5 In the **Select Study** tree, select **Preset Studies for Selected Physics Interfaces > Ray Tracing**.
- 6 Click  **Done**.

### GEOMETRY I

The geometry is set up by importing a geometry sequence. The sequence imports the small concert hall geometry and sets up several selections. The predefined selections simplify the rest of the model setup.

- 1 In the **Geometry** toolbar, click **Insert Sequence** and choose **Insert Sequence**.
- 2 Browse to the model's Application Libraries folder and double-click the file `small_concert_hall_geom_sequence.mph`.
- 3 In the **Geometry** toolbar, click  **Build All**.
- 4 Click the  **Wireframe Rendering** button in the **Graphics** toolbar.
- 5 Click the  **Zoom Extents** button in the **Graphics** toolbar.
- 6 In the **Model Builder** window, under **Component I (comp I)** click **Geometry I**.

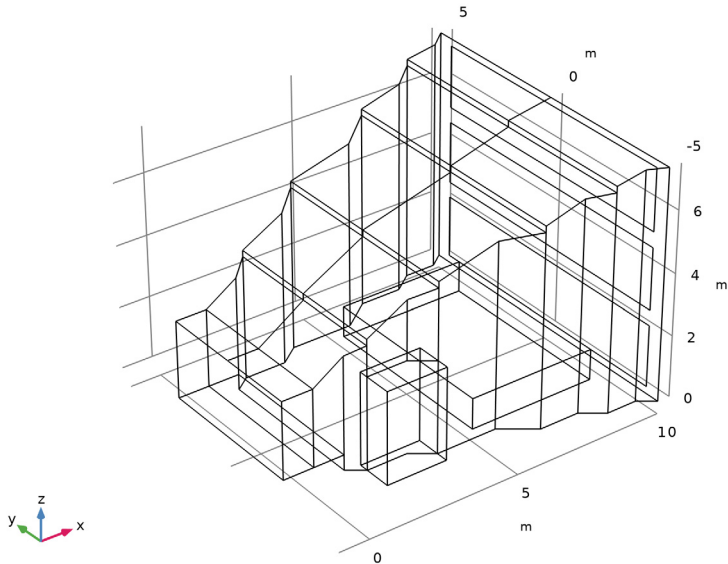



Import the model parameters from the files. The parameters include the band center frequency  $f_0$ , the location of the source and receiver, as well as the room volume.

## GLOBAL DEFINITIONS



### *Parameters 1 - Model*

- 1 In the **Model Builder** window, under **Global Definitions** click **Parameters 1**.
- 2 In the **Settings** window for **Parameters**, type Parameters 1 - Model in the **Label** text field.
- 3 Locate the **Parameters** section. Click  **Load from File**.
- 4 Browse to the model's Application Libraries folder and double-click the file `small_concert_hall_parameters_model.txt`.

### *Parameters 2 - Source and Receiver Positions*



- 1 In the **Home** toolbar, click  **Parameters** and choose **Add > Parameters**.
- 2 In the **Settings** window for **Parameters**, type Parameters 2 - Source and Receiver Positions in the **Label** text field.
- 3 Locate the **Parameters** section. Click  **Load from File**.
- 4 Browse to the model's Application Libraries folder and double-click the file `small_concert_hall_parameters_source_positions.txt`.

### *Parameters 3 - Source and Receiver Settings*

- 1 In the **Home** toolbar, click  **Parameters** and choose **Add > Parameters**.
- 2 In the **Settings** window for **Parameters**, type Parameters 3 - Source and Receiver Settings in the **Label** text field.
- 3 Locate the **Parameters** section. Click  **Load from File**.
- 4 Browse to the model's Application Libraries folder and double-click the file `small_concert_hall_parameters_source_settings.txt`.

Create an interpolation function to import the loudspeaker directivity data.

### *Interpolation 1 (int1)*

- 1 In the **Home** toolbar, click  **Functions** and choose **Global > Interpolation**.
- 2 In the **Settings** window for **Interpolation**, locate the **Definition** section.
- 3 From the **Data source** list, choose **File**.
- 4 Click  **Browse**.
- 5 Browse to the model's Application Libraries folder and double-click the file `small_concert_hall_radiation_balloon.txt`.
- 6 Click  **Import**.



- 7 Locate the **Data Column Settings** section. In the table, click to select the cell at row number 1 and column number 1.
- 8 In the **Unit** text field, type deg.
- 9 In the table, click to select the cell at row number 2 and column number 1.
- 10 In the **Unit** text field, type deg.
- 11 In the table, click to select the cell at row number 3 and column number 1.
- 12 In the **Unit** text field, type Hz.
- 13 In the table, click to select the cell at row number 4 and column number 1.
- 14 In the **Name** text field, type p<sub>real</sub>.
- 15 In the **Unit** text field, type Pa.
- 16 In the table, enter the following settings:

| Columns  | Type            | Settings            |
|----------|-----------------|---------------------|
| Column 5 | Function values | Function name=pimag |

- 17 In the **Name** text field, type p<sub>imag</sub>.
- 18 In the **Unit** text field, type Pa.

Proceed and set up interpolation functions for the absorption coefficients of the different surfaces in the concert hall. The data is easily stored in one .txt file. Also define an interpolation function for the amplitude attenuation of air (given at 50% relative humidity and 20°C).

#### *Interpolation 2 (int2)*

- 1 In the **Home** toolbar, click  **Functions** and choose **Global > Interpolation**.
- 2 In the **Settings** window for **Interpolation**, locate the **Definition** section.
- 3 From the **Data source** list, choose **File**.
- 4 Click  **Browse**.
- 5 Browse to the model's Application Libraries folder and double-click the file `small_concert_hall_absorption_parameters.txt`.
- 6 Click  **Import**.
- 7 Locate the **Data Column Settings** section. In the table, enter the following settings:

| Columns  | Type            | Settings            |
|----------|-----------------|---------------------|
| wall     | Function values | Function name=int2a |
| entrance | Function values | Function name=int2b |

| Columns   | Type            | Settings            |
|-----------|-----------------|---------------------|
| floor     | Function values | Function name=int2c |
| diffusers | Function values | Function name=int2d |
| seats     | Function values | Function name=int2e |
| absorbers | Function values | Function name=int2f |

**8** In the table, click to select the cell at row number 1 and column number 1.

**9** In the **Unit** text field, type Hz.

**10** In the table, click to select the cell at row number 2 and column number 1.

**11** In the **Name** text field, type a\_walls.

**12** In the **Unit** text field, type 1.

**13** In the table, click to select the cell at row number 3 and column number 1.

**14** In the **Name** text field, type a\_entrance.

**15** In the **Unit** text field, type 1.

**16** In the table, click to select the cell at row number 4 and column number 1.

**17** In the **Name** text field, type a\_windows.

**18** In the **Unit** text field, type 1.

**19** In the table, click to select the cell at row number 5 and column number 1.

**20** In the **Name** text field, type a\_floor.

**21** In the **Unit** text field, type 1.

**22** In the table, click to select the cell at row number 6 and column number 1.

**23** In the **Name** text field, type a\_diffuser.

**24** In the **Unit** text field, type 1.

**25** In the table, click to select the cell at row number 7 and column number 1.

**26** In the **Name** text field, type a\_seats.

**27** In the **Unit** text field, type 1.

**28** In the table, click to select the cell at row number 8 and column number 1.



**29** In the **Name** text field, type a\_absorbers.

**30** In the **Unit** text field, type 1.

### *Interpolation 3 (int3)*

**1** In the **Home** toolbar, click  **Functions** and choose **Global > Interpolation**.

**2** In the **Settings** window for **Interpolation**, locate the **Definition** section.

- 3 From the **Data source** list, choose **File**.
- 4 Click  **Browse**.
- 5 Browse to the model's Application Libraries folder and double-click the file `small_concert_hall_air_attenuation.txt`.
- 6 Click  **Import**.
- 7 In the **Function name** text field, type `a_air`.
- 8 Locate the **Interpolation and Extrapolation** section. From the **Interpolation** list, choose **Nearest neighbor**.
- 9 Locate the **Units** section. In the **Argument** table, enter the following settings:

| Argument | Unit |
|----------|------|
| t        | Hz   |

- 10 In the **Function** table, enter the following settings:

| Function | Unit |
|----------|------|
| a_air    | 1/m  |

Now create the rotated coordinate system that will represent the orientation of the directional loudspeaker. When working on your own model, it is recommended to run a quick study to visualize the coordinate system and ensure that the correct angles are entered.

## DEFINITIONS

### *Rotated System 2 (sys2)*

- 1 In the **Definitions** toolbar, click  **Coordinate Systems** and choose **Rotated System**.
- 2 In the **Settings** window for **Rotated System**, locate the **Rotation** section.
- 3 Find the **Euler angles** subsection. In the  $\alpha$  text field, type `alpha0`.
- 4 In the  $\beta$  text field, type `beta0`.
- 5 In the  $\gamma$  text field, type `gamma0`.



Add a point to the geometry to represent the loudspeaker position. This will allow to later plot the rotated coordinate system. Also add a sphere corresponding to the receiver. The default recommendation is to use a receiver radius of 0.3 m, which corresponds to the standard width of a seat. For different applications, especially smaller spaces like a car cabin, it is recommended to decrease the value of the receiver radius.

## GEOMETRY I

### *Point 1 (pt1)*

- 1 In the **Geometry** toolbar, click  **More Primitives** and choose **Point**.
- 2 In the **Settings** window for **Point**, locate the **Point** section.
- 3 In the **x** text field, type `x_spk`.
- 4 In the **y** text field, type `y_spk`.
- 5 In the **z** text field, type `z_spk`.

### *Sphere 1 (sph1)*

- 1 In the **Geometry** toolbar, click  **Sphere**.
- 2 In the **Settings** window for **Sphere**, locate the **Object Type** section.
- 3 From the **Type** list, choose **Surface**.
- 4 Locate the **Size** section. In the **Radius** text field, type `r_rec`.
- 5 Locate the **Position** section. In the **x** text field, type `x_rec`.
- 6 In the **y** text field, type `y_rec`.
- 7 In the **z** text field, type `z_rec`.
- 8 Locate the **Selections of Resulting Entities** section. Select the **Resulting objects selection** checkbox.
- 9 From the **Show in physics** list, choose **Boundary selection**.
- 10 In the **Geometry** toolbar, click  **Build All**.

Import the variables that define the room acoustic quality metric estimates. They include the reverberation time ( $T60$ ), based on the Sabine and Eyring estimation equations, clarity ( $C80$ ), definition ( $D$ ), and center time ( $t_s$ ). This also requires setting up integration operators for all the surfaces.

## DEFINITIONS

### *Integration 1 (intop1)*

- 1 In the **Model Builder** window, expand the **Component 1 (comp1) > Definitions** node.
- 2 Right-click **Definitions** and choose **Nonlocal Couplings > Integration**.
- 3 In the **Settings** window for **Integration**, type `intop_windows` in the **Operator name** text field.
- 4 Locate the **Source Selection** section. From the **Geometric entity level** list, choose **Boundary**.
- 5 From the **Selection** list, choose **Windows**.

#### *Integration 2 (intop2)*

- 1 In the **Definitions** toolbar, click  **Nonlocal Couplings** and choose **Integration**.
- 2 In the **Settings** window for **Integration**, type intop\_seats in the **Operator name** text field.
- 3 Locate the **Source Selection** section. From the **Geometric entity level** list, choose **Boundary**.
- 4 From the **Selection** list, choose **Seats**.

#### *Integration 3 (intop3)*

- 1 In the **Definitions** toolbar, click  **Nonlocal Couplings** and choose **Integration**.
- 2 In the **Settings** window for **Integration**, type intop\_diffusers in the **Operator name** text field.
- 3 Locate the **Source Selection** section. From the **Geometric entity level** list, choose **Boundary**.
- 4 From the **Selection** list, choose **Diffusers**.

#### *Integration 4 (intop4)*

- 1 In the **Definitions** toolbar, click  **Nonlocal Couplings** and choose **Integration**.
- 2 In the **Settings** window for **Integration**, type intop\_floor in the **Operator name** text field.
- 3 Locate the **Source Selection** section. From the **Geometric entity level** list, choose **Boundary**.
- 4 From the **Selection** list, choose **Floor**.

#### *Integration 5 (intop5)*

- 1 In the **Definitions** toolbar, click  **Nonlocal Couplings** and choose **Integration**.
- 2 In the **Settings** window for **Integration**, type intop\_entrance in the **Operator name** text field.
- 3 Locate the **Source Selection** section. From the **Geometric entity level** list, choose **Boundary**.
- 4 From the **Selection** list, choose **Entrance**.

#### *Integration 6 (intop6)*

- 1 In the **Definitions** toolbar, click  **Nonlocal Couplings** and choose **Integration**.
- 2 In the **Settings** window for **Integration**, type intop\_walls in the **Operator name** text field.

- 3 Locate the **Source Selection** section. From the **Geometric entity level** list, choose **Boundary**.
- 4 From the **Selection** list, choose **Walls**.

*Integration 7 (intop7)*

- 1 In the **Definitions** toolbar, click  **Nonlocal Couplings** and choose **Integration**.
- 2 In the **Settings** window for **Integration**, type intop\_absorbers in the **Operator name** text field.
- 3 Locate the **Source Selection** section. From the **Geometric entity level** list, choose **Boundary**.
- 4 From the **Selection** list, choose **Absorbers**.

*Variables: Quality Metric Estimates*

- 1 Right-click **Definitions** and choose **Variables**.
- 2 In the **Settings** window for **Variables**, type Variables: Quality Metric Estimates in the **Label** text field.
- 3 Locate the **Variables** section. Click  **Load from File**.
- 4 Browse to the model's Application Libraries folder and double-click the file small\_concert\_hall\_variables.txt.

Proceed to set up and define the physics and boundary conditions of the model. To compute the impulse response, it is necessary to model the power along the rays and count the reflections. In the model the intensity is also computed along the rays. The intensity represents spatially local properties of the acoustic field approximated by the rays. The model only uses a surface mesh. Propagation in the unmeshed domains requires the input of material properties at the interface level (in the section **Material Properties of Exterior and Unmeshed Domains**). Set up boundary conditions for the different walls. All the boundary conditions are defined as **Mixed diffuse and specular reflection**, with either a default or specific scattering coefficient.

**RAY ACOUSTICS (RAC)**

- 1 In the **Model Builder** window, under **Component 1 (comp1)** click **Ray Acoustics (rac)**.
- 2 In the **Settings** window for **Ray Acoustics**, locate the **Intensity Computation** section.
- 3 From the **Intensity computation** list, choose **Compute intensity and power**.
- 4 Locate the **Material Properties of Exterior and Unmeshed Domains** section. In the  $c_{\text{ext}}$  text field, type c0.
- 5 In the  $\rho_{\text{ext}}$  text field, type rho0.

6 In the  $\alpha_{\text{ext}}$  text field, type `a_air(f0)`.

#### *Ray Properties I*

- 1 In the **Model Builder** window, under **Component 1 (comp1) > Ray Acoustics (rac)** click **Ray Properties I**.
- 2 In the **Settings** window for **Ray Properties**, locate the **Ray Properties** section.
- 3 In the  $f$  text field, type `f0`.

#### *Wall: Walls*

- 1 In the **Physics** toolbar, click  **Boundaries** and choose **Wall**.
- 2 In the **Settings** window for **Wall**, type `Wall: Walls` in the **Label** text field.
- 3 Locate the **Boundary Selection** section. From the **Selection** list, choose **Walls**.
- 4 Locate the **Wall Condition** section. In the  $s$  text field, type `s_default`.
- 5 In the  $\alpha$  text field, type `a_walls(f0)`.

#### *Wall: Entrance*

- 1 In the **Physics** toolbar, click  **Boundaries** and choose **Wall**.
- 2 In the **Settings** window for **Wall**, type `Wall: Entrance` in the **Label** text field.
- 3 Locate the **Boundary Selection** section. From the **Selection** list, choose **Entrance**.
- 4 Locate the **Wall Condition** section. In the  $s$  text field, type `s_default`.
- 5 In the  $\alpha$  text field, type `a_entrance(f0)`.

#### *Wall: Windows*

- 1 In the **Physics** toolbar, click  **Boundaries** and choose **Wall**.
- 2 In the **Settings** window for **Wall**, type `Wall: Windows` in the **Label** text field.
- 3 Locate the **Boundary Selection** section. From the **Selection** list, choose **Windows**.
- 4 Locate the **Wall Condition** section. In the  $s$  text field, type `s_default`.
- 5 In the  $\alpha$  text field, type `a_windows(f0)`.

#### *Wall: Floor*

- 1 In the **Physics** toolbar, click  **Boundaries** and choose **Wall**.
- 2 In the **Settings** window for **Wall**, type `Wall: Floor` in the **Label** text field.
- 3 Locate the **Boundary Selection** section. From the **Selection** list, choose **Floor**.
- 4 Locate the **Wall Condition** section. In the  $s$  text field, type `s_default`.
- 5 In the  $\alpha$  text field, type `a_floor(f0)`.

#### Wall: Diffusers

- 1 In the **Physics** toolbar, click  **Boundaries** and choose **Wall**.
- 2 In the **Settings** window for **Wall**, type Wall: Diffusers in the **Label** text field.
- 3 Locate the **Boundary Selection** section. From the **Selection** list, choose **Diffusers**.
- 4 Locate the **Wall Condition** section. In the *s* text field, type `s_diffuser`.
- 5 In the  $\alpha$  text field, type `a_diffuser(f0)`.

In this model the scattering coefficient `s_diffuser` is constant across the frequency bands. It can of course also be defined as an interpolation function that depends on `f0`.

#### Wall: Absorbers

- 1 In the **Physics** toolbar, click  **Boundaries** and choose **Wall**.
- 2 In the **Settings** window for **Wall**, type Wall: Absorbers in the **Label** text field.
- 3 Locate the **Boundary Selection** section. From the **Selection** list, choose **Absorbers**.
- 4 Locate the **Wall Condition** section. In the *s* text field, type `s_default`.
- 5 In the  $\alpha$  text field, type `a_absorbers(f0)`.

#### Wall: Seats (Top)

- 1 In the **Physics** toolbar, click  **Boundaries** and choose **Wall**.
- 2 In the **Settings** window for **Wall**, type Wall: Seats (Top) in the **Label** text field.
- 3 Locate the **Boundary Selection** section. From the **Selection** list, choose **Manual**.
- 4 Select Boundary 41 only.
- 5 Locate the **Wall Condition** section. In the *s* text field, type `s_seats`.
- 6 In the  $\alpha$  text field, type `a_seats(f0)`.

#### Sound Pressure Level Calculation I

- 1 In the **Physics** toolbar, click  **Attributes** and choose **Sound Pressure Level Calculation**.
- 2 In the **Settings** window for **Sound Pressure Level Calculation**, locate the **Smoothing** section.
- 3 Select the **Compute smoothed accumulated variable** checkbox.

#### Wall: Seats (Around)

- 1 In the **Physics** toolbar, click  **Boundaries** and choose **Wall**.
- 2 In the **Settings** window for **Wall**, type Wall: Seats (Around) in the **Label** text field.
- 3 Locate the **Boundary Selection** section. From the **Selection** list, choose **Manual**.
- 4 Select Boundaries 39, 40, 42, and 67 only.

- 5 Locate the **Wall Condition** section. In the  $s$  text field, type `s_seats`.
- 6 In the  $\alpha$  text field, type `a_seats(f0)`.

The source is defined here with its spatial directivity, reference level, and reference distance. For spatial directivity, the default value shows the angle variables in the cosine and sine expressions needed to define the directivity. In this case, it is set to 0[dB] to obtain an omnidirectional point source.

*Source with Directivity 1*

- 1 In the **Physics** toolbar, click  **Global** and choose **Source with Directivity**.
- 2 In the **Settings** window for **Source with Directivity**, locate the **Initial Position** section.
- 3 Specify the  $\mathbf{q}_0$  vector as

|       |   |
|-------|---|
| x_src | x |
| y_src | y |
| z_src | z |

- 4 Locate the **Ray Direction Vector** section. In the  $N_w$  text field, type `Nrays`.
- 5 Locate the **Intensity and Power** section. In the  $D(\varphi, \theta)$  text field, type 0[dB].
- 6 In the  $L_{ref}$  text field, type `L0_src`.
- 7 In the  $R_{ref}$  text field, type `R0_src`.

A second source is included in the model to demonstrate the case of a directional loudspeaker source. In this case, the radiation data is given as the sound pressure measured one meter away from the source; it therefore needs to be converted to sound pressure level.

*Source with Directivity 2*

- 1 In the **Physics** toolbar, click  **Global** and choose **Source with Directivity**.
- 2 In the **Settings** window for **Source with Directivity**, locate the **Coordinate System Selection** section.
- 3 From the **Coordinate system** list, choose **Rotated System 2 (sys2)**.
- 4 Locate the **Initial Position** section. Specify the  $\mathbf{q}_0$  vector as

|       |   |
|-------|---|
| x_spk | x |
| y_spk | y |
| z_spk | z |

- 5 Locate the **Ray Direction Vector** section. In the  $N_w$  text field, type `Nrays`.

- 6 Locate the **Intensity and Power** section. In the  $D(\varphi\theta,)$  text field, type  $20^* \log_{10}(\text{abs}(\text{preal}(\text{rac}.\text{swd2}.\text{phi}, \text{rac}.\text{swd2}.\text{theta}, \text{f0}) + i * \text{pimag}(\text{rac}.\text{swd2}.\text{phi}, \text{rac}.\text{swd2}.\text{theta}, \text{f0})) / \text{sqrt}(2) / 20\text{e-}6[\text{Pa}])$ .
- 7 In the  $L_{\text{ref}}$  text field, type L0\_spk.
- 8 In the  $R_{\text{ref}}$  text field, type R0\_spk.

#### Ray Termination I

- 1 In the **Physics** toolbar, click  **Global** and choose **Ray Termination**.

Add a termination condition to end the propagation of rays once their energy drops below a certain threshold. This makes computations faster by removing rays which do not have a significant contribution anymore. The *if* statement and *isdefined* operator allow to select the correct variable according to the active source.

- 2 In the **Settings** window for **Ray Termination**, locate the **Termination Criteria** section.
- 3 From the **Spatial extents of ray propagation** list, choose **Bounding box, from geometry**.
- 4 From the **Additional termination criteria** list, choose **Power**.
- 5 In the  $Q_{\text{th}}$  text field, type  $\text{if}(\text{isdefined}(\text{rac}.\text{swd1}.\text{Q0}), \text{rac}.\text{swd1}.\text{Q0} * 1\text{e-}7, \text{rac}.\text{swd2}.\text{Q0} * 1\text{e-}7)$ .

The **Receiver** feature allows to gather the data needed for **Impulse Response** plots while solving the model, making postprocessing nearly instantaneous without affecting solution time.

#### Receiver I

- 1 In the **Physics** toolbar, click  **Boundaries** and choose **Receiver**.
- 2 In the **Settings** window for **Receiver**, locate the **Boundary Selection** section.
- 3 From the **Selection** list, choose **Sphere I**.

Now create the mesh. In ray tracing simulations for room acoustics, the mesh is used to detect the collisions between rays and boundaries. Therefore, only the boundaries need to be meshed and the element size can be set to a coarse value without compromising accuracy.

#### MESH I

- 1 In the **Model Builder** window, under **Component 1 (comp1)** click **Mesh I**.
- 2 In the **Settings** window for **Mesh**, locate the **Physics-Controlled Mesh** section.
- 3 From the **Element size** list, choose **Extra coarse**.

- 4 Locate the **Sequence Type** section. From the list, choose **User-controlled mesh**.  
Add a finer mesh on the surface where the SPL is computed and on the receiver sphere.

#### *Size 2*

- 1 In the **Model Builder** window, under **Component 1 (comp1) > Mesh 1** click **Size 2**.
- 2 In the **Settings** window for **Size**, locate the **Element Size Parameters** section.
- 3 In the **Maximum element size** text field, type  $r_{rec}/3$ .
- 4 Clear the **Minimum element size** checkbox.



#### *Free Triangular 1*

- 1 In the **Model Builder** window, click **Free Triangular 1**.
- 2 In the **Settings** window for **Free Triangular**, locate the **Boundary Selection** section.
- 3 From the **Selection** list, choose **All boundaries**.

#### *Size 1*

- 1 Right-click **Free Triangular 1** and choose **Size**.
- 2 In the **Settings** window for **Size**, locate the **Geometric Entity Selection** section.
- 3 Click  **Clear Selection**.
- 4 Select Boundary 41 only.
- 5 Locate the **Element Size** section. Click the **Custom** button.
- 6 Locate the **Element Size Parameters** section.
- 7 Select the **Maximum element size** checkbox. In the associated text field, type 0.3.  
Mesh the vertices that are not part of the model boundaries, in this case the geometry point representing the directional loudspeaker..

#### *Vertex 1*

- 1 In the **Mesh** toolbar, click  **More Generators** and choose **Vertex**.
- 2 In the **Settings** window for **Vertex**, locate the **Point Selection** section.
- 3 Click  **Paste Selection**.
- 4 In the **Paste Selection** dialog, type 11 in the **Selection** text field.
- 5 Click **OK**.

6 In the **Settings** window for **Vertex**, click  **Build All**.

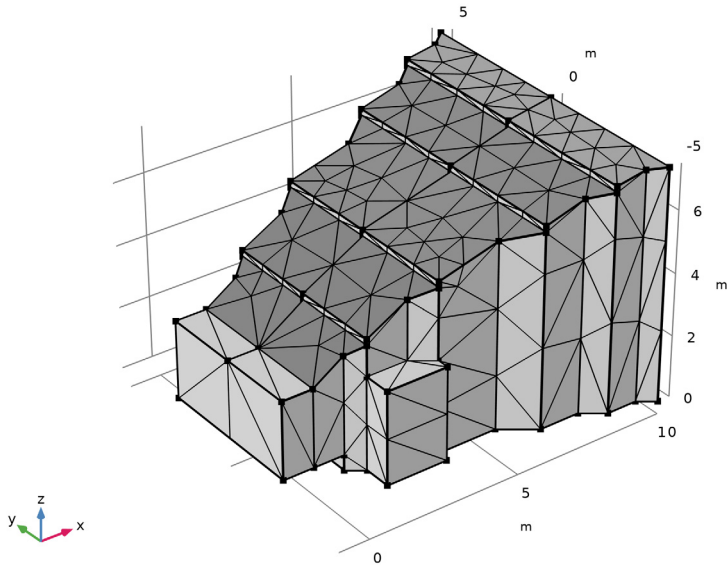

Proceed and solve the model with the omnidirectional source by adding a parametric sweep over the center frequency variable  $f_0$ . This represents the center frequency of the octave bands analyzed in this model, in order to get a broadband response. The first time you set up and solve the model it can be useful to reduce the number of rays by changing the value of the parameter  $N_{\text{rays}}$  to, for example, 1000. This will make solving and postprocessing faster. Remember that the quality of the results in acoustic ray tracing increase for an increasing number of rays and more narrow frequency bands (given boundary condition data with the adequate resolution). In the *Ray Acoustics* interface the impulse response plot can handle octave, 1/3-octave, and 1/6-octave data.

#### **STUDY 1 - OMNIDIRECTIONAL SOURCE**



- 1 In the **Model Builder** window, click **Study 1**.
- 2 In the **Settings** window for **Study**, type Study 1 - Omnidirectional Source in the **Label** text field.

##### *Step 1: Ray Tracing*

- 1 In the **Model Builder** window, under **Study 1 - Omnidirectional Source** click **Step 1: Ray Tracing**.
- 2 In the **Settings** window for **Ray Tracing**, locate the **Study Settings** section.

- 3 From the **Time unit** list, choose **s**.
- 4 In the **Output times** text field, type 0 1.6.  
For optimal performance only enter 0 and the end time for the simulation. In postprocessing, when reconstructing the impulse response, additional exact time steps for all the wall reflections are used and rendered.
- 5 Locate the **Physics and Variables Selection** section. Select the **Modify model configuration for study step** checkbox.
- 6 In the tree, select **Component 1 (comp1) > Ray Acoustics (rac) > Source with Directivity 2**.
- 7 Click  **Disable**.

#### Parametric Sweep

- 1 In the **Study** toolbar, click  **Parametric Sweep**.  
Using the parametric sweep is important as this gives the frequency resolution (here in full octaves). The ray propagation model is solved once per frequency band.
- 2 In the **Settings** window for **Parametric Sweep**, locate the **Study Settings** section.
- 3 Click  **Add**.
- 4 In the table, enter the following settings:

| Parameter name             | Parameter value list | Parameter unit |
|----------------------------|----------------------|----------------|
| f0 (Band center frequency) |                      | Hz             |

- 5 In the table, click to select the cell at row number 1 and column number 2.
- 6 Click  **Range**.
- 7 In the **Range** dialog, choose **ISO preferred frequencies** from the **Entry method** list.
- 8 In the **Start frequency** text field, type 125.
- 9 In the **Stop frequency** text field, type 8000.
- 10 Click **Replace**.

Solving the model takes a couple of minutes and uses less than 4 GB of RAM (depending on your hardware). This will increase for an increasing number of rays.

- 11 In the **Study** toolbar, click  **Compute**.

## RESULTS

#### Ray Trajectories (rac)

- 1 In the **Settings** window for **3D Plot Group**, locate the **Data** section.
- 2 From the **Time (s)** list, choose **Interpolation**.

- 3 In the **Time** text field, type 10[ms].
- 4 In the **Ray Trajectories (rac)** toolbar, click  **Plot**.

#### *Ray Trajectories I*

- 1 In the **Model Builder** window, expand the **Ray Trajectories (rac)** node, then click **Ray Trajectories I**.
- 2 In the **Settings** window for **Ray Trajectories**, locate the **Coloring and Style** section.
- 3 Find the **Line style** subsection. From the **Type** list, choose **None**.
- 4 Find the **Point style** subsection. From the **Type** list, choose **Point**.

#### *Color Expression I*



- 1 In the **Model Builder** window, expand the **Ray Trajectories I** node, then click **Color Expression I**.
- 2 In the **Settings** window for **Color Expression**, locate the **Expression** section.
- 3 In the **Expression** text field, type `rac.Lp`.
- 4 In the **Ray Trajectories (rac)** toolbar, click  **Plot**.  
This should reproduce the image in [Figure 2](#).

#### *Ray Trajectories (rac)*

- 1 In the **Model Builder** window, under **Results** click **Ray Trajectories (rac)**.
- 2 In the **Settings** window for **3D Plot Group**, locate the **Data** section.
- 3 In the **Time** text field, type 20[ms].
- 4 In the **Ray Trajectories (rac)** toolbar, click  **Plot**.  
This should reproduce the image in [Figure 3](#).

Create an animation to visualize early reflections and wave patterns.

#### *Animation I*

- 1 In the **Results** toolbar, click  **Animation** and choose **Player**.
- 2 In the **Settings** window for **Animation**, locate the **Animation Editing** section.
- 3 From the **Time selection** list, choose **Interpolated**.
- 4 Click  **Range**.
- 5 In the **Range** dialog, type 3[ms] in the **Start** text field.
- 6 In the **Step** text field, type 1[ms].
- 7 In the **Stop** text field, type 50[ms].
- 8 Click **Replace**.

**9** In the **Settings** window for **Animation**, locate the **Frames** section.

**10** In the **Number of frames** text field, type 48.

**11** Click the  **Play** button in the **Graphics** toolbar.

On the **Results** node select the following options to facilitate the postprocessing workflow.

**12** In the **Model Builder** window, click **Results**.

**13** In the **Settings** window for **Results**, locate the **Update of Results** section.

**14** Select the **Only plot when requested** checkbox.

**15** Select the **Recompute all plot data after solving** checkbox.

**16** Locate the **Save Data in the Model** section. From the **Save plot data** list, choose **On**.

Also turn on the **Plot Information Section** to display rendering time and other useful information. This option applies to the whole COMSOL installation; if selected, the **Plot Information Section** will also appear in other models opened at a later stage.

**17** Click the  **Show More Options** button in the **Model Builder** toolbar.

**18** In the **Show More Options** dialog, select **Results > Information Section** in the tree.

**19** In the tree, select the checkbox for the node **Results > Information Section**.

**20** Click **OK**.

#### *Receiver 3D - All Bands*

**1** In the **Model Builder** window, expand the **Results > Datasets** node, then click **Receiver 3D 1**.

**2** In the **Settings** window for **Receiver 3D**, type Receiver 3D - All Bands in the **Label** text field.

#### *Receiver 3D - 125 Hz Band*

**1** In the **Model Builder** window, right-click **Receiver 3D - All Bands** and choose **Duplicate**.

**2** In the **Settings** window for **Receiver 3D**, type Receiver 3D - 125 Hz Band in the **Label** text field.

**3** Locate the **Data** section. From the **Parameter selection (f0)** list, choose **From list**.

**4** In the **Parameter values (f0 (Hz))** list box, select **125**.

#### *Receiver 3D - 8 kHz Band*

**1** In the **Model Builder** window, right-click **Receiver 3D - 125 Hz Band** and choose **Duplicate**.



**2** In the **Settings** window for **Receiver 3D**, type Receiver 3D - 8 kHz Band in the **Label** text field.

- 3 Locate the **Data** section. From the **Parameter selection (f0)** list, choose **From list**.
- 4 In the **Parameter values (f0 (Hz))** list box, select **8000**.

#### *Impulse Response*

- 1 In the **Results** toolbar, click  **ID Plot Group**.
- 2 In the **Settings** window for **ID Plot Group**, type **Impulse Response** in the **Label** text field.
- 3 Locate the **Data** section. From the **Dataset** list, choose **Receiver 3D - All Bands**.

#### *Impulse Response I*

- 1 In the **Impulse Response** toolbar, click  **More Plots** and choose **Impulse Response**.  
To get sharper filters you can modify the settings in the **Advanced** section.
- 2 In the **Settings** window for **Impulse Response**, click to expand the **Advanced** section.
- 3 In the  $N_p$  text field, type 22050.
- 4 In the  $\delta$  text field, type 0.001.
- 5 In the **Impulse Response** toolbar, click  **Plot**.

This should reproduce the impulse response shown in [Figure 4](#). The impulse response is the most important result of this model. The signal can be exported under the **Export** node and used for further analysis in an external signal processing tool. The response is reconstructed from the ray data detected by the **Receiver** dataset (arrival time, power, and band center frequency). It has a default sampling frequency of 44100 Hz, which can be changed under the **Advanced** section in the plot settings window.



#### *Plot I*

- 1 Right-click **Impulse Response I** and choose **Add Plot Data to Export**.
- 2 In the **Settings** window for **Plot**, locate the **Output** section.
- 3 From the **File type** list, choose **WAV audio file (\*.wav; \*.wave)**.
- 4 In the **Filename** text field, type `small_concert_hall_impulse_response.wav`.
- 5 Click to expand the **Advanced** section. From the **Encoding** list, choose **16-bit**.

Click **Export** to produce a .wav file of the impulse response, which could be used for auralization or analysis. Remember to disable any **Energy Decay** subfeature before exporting.

Proceed to analyze the impulse response with the **Energy Decay** subfeature. This will create a plot of the level/energy decay and a table with the objective quality metrics.

### Energy Decay I

- 1 In the **Model Builder** window, expand the **Results > Impulse Response** node.
- 2 Right-click **Impulse Response I** and choose **Energy Decay**.
- 3 In the **Settings** window for **Energy Decay**, locate the **Display** section.
- 4 From the **Band type** list, choose **Individual bands**.
- 5 From the **Band frequency** list, choose **All frequencies**.
- 6 From the **Plot** list, choose **Level decay**.
- 7 Locate the **Table** section. Find the **Early energy** subsection. Clear the **C<sub>50</sub>, Clarity** checkbox.
- 8 Clear the **t<sub>r</sub>, First ray arrival time** checkbox.
- 9 Find the **Speech intelligibility** subsection. Clear the **SNR, Apparent SNR** checkbox.
- 10 Click the  **Show Legends** button in the **Graphics** toolbar.
- 11 In the **Impulse Response** toolbar, click  **Plot**.



This should reproduce the image in [Figure 6](#).

To show the impulse response signal again, simply disable the **Energy Decay** subfeature and click **Plot**.

For the sake of this tutorial, the impulse response is imported and a Fourier transform of the transient signal is performed to obtain the frequency response of the room. Generally speaking, it would be more straightforward to disable the **Energy Decay** subfeature and apply the Fourier transform to the already existing plot.

### GLOBAL DEFINITIONS

#### Interpolation 4 (int4)

- 1 In the **Home** toolbar, click  **Functions** and choose **Global > Interpolation**.
- 2 In the **Settings** window for **Interpolation**, locate the **Definition** section.
- 3 From the **Data source** list, choose **File**.
- 4 Click  **Browse**.
- 5 Browse to the model's Application Libraries folder and double-click the file `small_concert_hall_impulse_response.wav`.
- 6 Find the **Functions** subsection. In the table, enter the following settings:

| Function name | Position in file |
|---------------|------------------|
| IR_import     | 1                |

7 Locate the **Units** section. In the **Function** table, enter the following settings:

| Function  | Unit |
|-----------|------|
| IR_import | Pa   |

8 In the **Argument** table, enter the following settings:

| Argument | Unit |
|----------|------|
| Column 1 | s    |

Update the solution of the study to include the interpolation function newly created.

### STUDY 1 - OMNIDIRECTIONAL SOURCE

In the **Study** toolbar, click  **Update Solution**.

### RESULTS

#### *Impulse Response 1*

- 1 In the **Model Builder** window, right-click **Impulse Response** and choose **Duplicate**.
- 2 Expand the **Impulse Response 1** node.

#### *Energy Decay 1*

- 1 In the **Model Builder** window, expand the **Results > Impulse Response 1 > Impulse Response 1** node.
- 2 Right-click **Energy Decay 1** and choose **Disable**.

#### *Impulse Response FFT*

- 1 In the **Model Builder** window, under **Results** click **Impulse Response 1**.
- 2 In the **Settings** window for **ID Plot Group**, type Impulse Response FFT in the **Label** text field.
- 3 Locate the **Axis** section. Select the **x-axis log scale** checkbox.
- 4 Locate the **Legend** section. Clear the **Show legends** checkbox.

When performing an FFT, the energy contained in the time signal is split between positive and negative frequencies. The **Show > Frequency spectrum** option with **Scale > Multiply by sampling period** applies the correct scaling factors to obtain physically meaningful results in dB for positive frequencies.

#### *Impulse Response 1*

- 1 In the **Model Builder** window, click **Impulse Response 1**.
- 2 In the **Settings** window for **Impulse Response**, locate the **Data** section.

- 3 From the **Source** list, choose **Function**.
- 4 From the **Function** list, choose **Interpolation 4 (IR\_import)**.
- 5 Locate the **Expression** section. In the **Expression** text field, type `IR_import(t)`.
- 6 Locate the **x-Axis Data** section. From the **Transformation** list, choose **Discrete Fourier transform**.
- 7 From the **Show** list, choose **Frequency spectrum**.
- 8 From the **Scale** list, choose **Multiply by sampling period**.
- 9 Select the **Frequency range** checkbox.
- 10 In the **Minimum** text field, type 100.
- 11 In the **Maximum** text field, type 10000.
- 12 Select the **In dB** checkbox.
- 13 From the **dB type** list, choose **20log**.
- 14 From the **dB reference** list, choose **Manual**.
- 15 In the **Reference value** text field, type `20e-6`.
- 16 In the **Impulse Response FFT** toolbar, click  **Plot**.

This is the raw transfer function of the room (no smoothing).

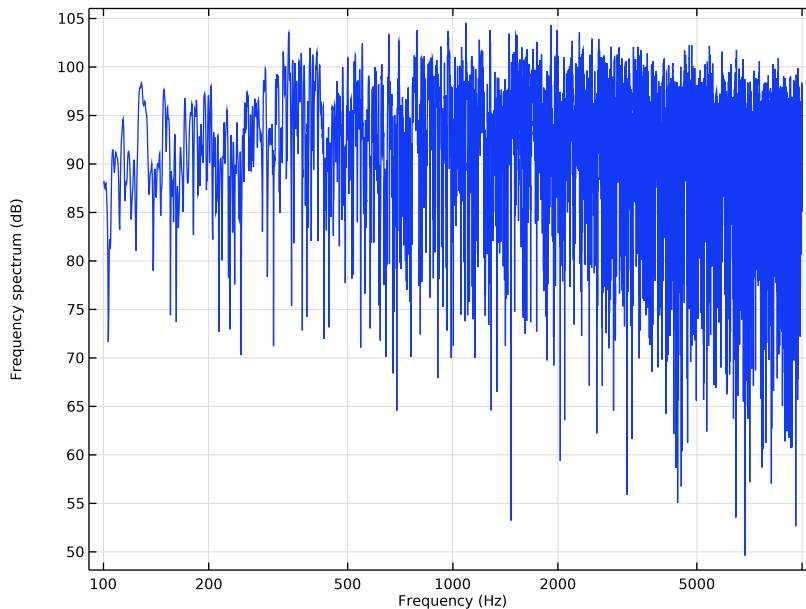

- 17 In the **Model Builder** window, click **Impulse Response 1**.

**18** Locate the **Smoothing** section. Select the **Moving average** checkbox.

**19** From the **Type** list, choose **1/n octave**.

**20** In the **n** text field, type 3.

**21** In the **Impulse Response FFT** toolbar, click  **Plot**.

This should reproduce the image in [Figure 5](#).

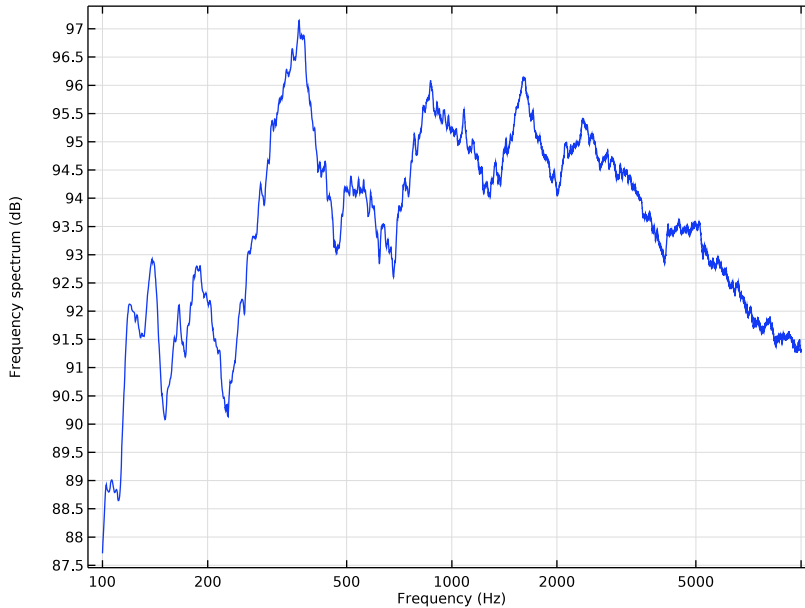

### Seats SPL

**1** In the **Results** toolbar, click  **3D Plot Group**.

**2** In the **Settings** window for **3D Plot Group**, type **Seats SPL** in the **Label** text field.

**3** Locate the **Data** section. From the **Dataset** list, choose **Study 1 - Omnidirectional Source/ Parametric Solutions 1 (sol2)**.

**4** Locate the **Color Legend** section. Select the **Show units** checkbox.

### Surface 1

**1** Right-click **Seats SPL** and choose **Surface**.

**2** In the **Settings** window for **Surface**, click **Replace Expression** in the upper-right corner of the **Expression** section. From the menu, choose **Component 1 (comp1) > Ray Acoustics > Accumulated variables > Wall intensity comp1.rac.wall8.sp1.lw > rac.wall8.sp1.Lp - Sound pressure level - dB**.

3 Locate the **Expression** section. From the **Unit** list, choose **dB**.

4 In the **Seats SPL** toolbar, click  **Plot**.

This should reproduce the image in [Figure 7](#). The 8 kHz band is chosen per default. A smoothed variable for the SPL also exists `rac.wall8.spl1.Lp_sm`.

### *Reflectogram*

1 In the **Results** toolbar, click  **ID Plot Group**.

2 In the **Settings** window for **ID Plot Group**, type `Reflectogram` in the **Label** text field.

3 Click to expand the **Title** section. From the **Title type** list, choose **Label**.

4 Locate the **Plot Settings** section.

5 Select the **x-axis label** checkbox. In the associated text field, type `t (s)`.

6 Select the **y-axis label** checkbox. In the associated text field, type `log10(Power)`.

7 Locate the **Data** section. From the **Dataset** list, choose **None**.

8 Locate the **Axis** section. Select the **y-axis log scale** checkbox.

### *Ray 1*

1 In the **Reflectogram** toolbar, click  **More Plots** and choose **Ray**.

2 In the **Settings** window for **Ray**, locate the **Data** section.

3 From the **Dataset** list, choose **Receiver 3D - 125 Hz Band**.

4 Locate the **y-Axis Data** section. In the **Expression** text field, type `re1dist*rac.Q/re1vol`.

5 Click to expand the **Coloring and Style** section. Find the **Line style** subsection. From the **Line** list, choose **None**.

6 Find the **Line markers** subsection. From the **Marker** list, choose **Point**.

7 Click to expand the **Legends** section. From the **Legends** list, choose **Manual**.

8 Select the **Show legends** checkbox.

9 In the table, enter the following settings:

---

#### **Legends**

---

`f<sub>c</sub> = 125 Hz`

---

### *Ray 2*

1 Right-click **Ray 1** and choose **Duplicate**.

2 In the **Settings** window for **Ray**, locate the **Data** section.

3 From the **Dataset** list, choose **Receiver 3D - 8 kHz Band**.

4 Locate the **Legends** section. In the table, enter the following settings:

| <b>Legends</b> |           |
|----------------|-----------|
| $f_c$          | = 8000 Hz |

5 In the **Reflectogram** toolbar, click  **Plot**.

This should reproduce the image in [Figure 8](#).

#### *T60 - Estimates and Model*

1 In the **Results** toolbar, click  **ID Plot Group**.

2 In the **Settings** window for **ID Plot Group**, type T60 - Estimates and Model in the **Label** text field.

3 Locate the **Data** section. From the **Dataset** list, choose **Study 1 - Omnidirectional Source/ Parametric Solutions 1 (sol2)**.

4 From the **Time selection** list, choose **First**.

5 Click to expand the **Title** section. From the **Title type** list, choose **Label**.

6 Locate the **Plot Settings** section.

7 Select the **x-axis label** checkbox. In the associated text field, type  $f_c$  (Hz).

8 Locate the **Axis** section. Select the **Manual axis limits** checkbox.

9 In the **x minimum** text field, type 120.

10 In the **x maximum** text field, type 8322.

11 In the **y minimum** text field, type 0.

12 In the **y maximum** text field, type 1.6.

13 Select the **x-axis log scale** checkbox.

14 Locate the **Legend** section. From the **Position** list, choose **Lower left**.

#### *Global 1*

1 Right-click **T60 - Estimates and Model** and choose **Global**.

2 In the **Settings** window for **Global**, locate the **y-Axis Data** section.

3 In the table, enter the following settings:

| <b>Expression</b> | <b>Unit</b> | <b>Description</b>                             |
|-------------------|-------------|--|
| T60_S             | s           | Reverberation time (Sabine)                    |
| T60_Sna           | s           | Reverberation time (Sabine, no air absorption) |
| T60_E             | s           | Reverberation time (Eyring)                    |

4 Locate the **x-Axis Data** section. From the **Axis source data** list, choose **f0**.

- 5 Click to expand the **Coloring and Style** section. Find the **Line markers** subsection. From the **Marker** list, choose **Star**.

#### *Table Graph 1*

- 1 In the **Model Builder** window, right-click **T60 - Estimates and Model** and choose **Table Graph**.
- 2 In the **Settings** window for **Table Graph**, locate the **Data** section.
- 3 From the **x-axis data** list, choose **fc (Hz)**.
- 4 From the **Plot columns** list, choose **Manual**.
- 5 In the **Columns** list box, select **T60 (s)**.
- 6 Locate the **Coloring and Style** section. Find the **Line markers** subsection. From the **Marker** list, choose **Circle**.
- 7 Click to expand the **Legends** section. Select the **Show legends** checkbox.
- 8 Find the **Prefix and suffix** subsection. In the **Suffix** text field, type **- Ray acoustics**.
- 9 In the **T60 - Estimates and Model** toolbar, click  **Plot**.  
This should reproduce the image in [Figure 9](#).

#### *Definition*

- 1 In the **Results** toolbar, click  **ID Plot Group**.
- 2 In the **Settings** window for **ID Plot Group**, type **Definition** in the **Label** text field.
- 3 Locate the **Data** section. From the **Dataset** list, choose **Study 1 - Omnidirectional Source/ Parametric Solutions 1 (sol2)**.
- 4 From the **Time selection** list, choose **First**.
- 5 Click to expand the **Title** section. From the **Title type** list, choose **Label**.
- 6 Locate the **Plot Settings** section.
- 7 Select the **x-axis label** checkbox. In the associated text field, type  $f_{c}$  (Hz).
- 8 Select the **y-axis label** checkbox. In the associated text field, type **D (%)**.
- 9 Locate the **Axis** section. Select the **Manual axis limits** checkbox.
- 10 In the **x minimum** text field, type **120**.
- 11 In the **x maximum** text field, type **8322**.
- 12 In the **y minimum** text field, type **0**.
- 13 In the **y maximum** text field, type **100**.
- 14 Select the **x-axis log scale** checkbox.
- 15 Locate the **Legend** section. From the **Position** list, choose **Upper left**.

### Global 1

- 1 Right-click **Definition** and choose **Global**.
- 2 In the **Settings** window for **Global**, locate the **y-Axis Data** section.
- 3 In the table, enter the following settings:

| Expression | Unit | Description         |
|------------|------|---------------------|
| D          | s    | Definition estimate |

- 4 Locate the **x-Axis Data** section. From the **Axis source data** list, choose **f0**.
- 5 Click to expand the **Coloring and Style** section. Find the **Line markers** subsection. From the **Marker** list, choose **Star**.

### Table Graph 1

- 1 In the **Model Builder** window, right-click **Definition** and choose **Table Graph**.
- 2 In the **Settings** window for **Table Graph**, locate the **Data** section.
- 3 From the **x-axis data** list, choose **fc (Hz)**.
- 4 From the **Plot columns** list, choose **Manual**.
- 5 In the **Columns** list box, select **D (%)**.
- 6 Locate the **Coloring and Style** section. Find the **Line markers** subsection. From the **Marker** list, choose **Circle**.
- 7 Click to expand the **Legends** section. Select the **Show legends** checkbox.
- 8 Find the **Prefix and suffix** subsection. In the **Suffix** text field, type **- Ray acoustics**.
- 9 In the **Definition** toolbar, click  **Plot**.

This should reproduce the first image in [Figure 10](#).

### Clarity

- 1 Right-click **Definition** and choose **Duplicate**.
- 2 In the **Settings** window for **ID Plot Group**, type **Clarity** in the **Label** text field.
- 3 Locate the **Plot Settings** section. In the **y-axis label** text field, type **C80 (dB)**.
- 4 Locate the **Axis** section. In the **x minimum** text field, type **120**.
- 5 In the **x maximum** text field, type **8322**.
- 6 In the **y minimum** text field, type **-1**.
- 7 In the **y maximum** text field, type **10**.

### Global 1

- 1 In the **Model Builder** window, expand the **Clarity** node, then click **Global 1**.

- 2 In the **Settings** window for **Global**, locate the **y-Axis Data** section.
- 3 In the table, enter the following settings:

| Expression | Unit | Description         |
|------------|------|---------------------|
| C80        |      | Clarity 80 estimate |

#### *Table Graph 1*

- 1 In the **Model Builder** window, click **Table Graph 1**.
- 2 In the **Settings** window for **Table Graph**, locate the **Data** section.
- 3 In the **Columns** list box, select **C80 (dB)**.
- 4 In the **Clarity** toolbar, click  **Plot**.

This should reproduce the second image in [Figure 10](#).

#### *Center Time*

- 1 In the **Model Builder** window, right-click **Clarity** and choose **Duplicate**.
- 2 In the **Settings** window for **ID Plot Group**, type Center Time in the **Label** text field.
- 3 Locate the **Plot Settings** section. In the **y-axis label** text field, type ts (s).
- 4 Locate the **Axis** section. In the **x minimum** text field, type 120.
- 5 In the **x maximum** text field, type 8322.
- 6 In the **y minimum** text field, type 0.
- 7 In the **y maximum** text field, type 0.15.
- 8 Locate the **Legend** section. From the **Position** list, choose **Lower left**.

#### *Global 1*

- 1 In the **Model Builder** window, expand the **Center Time** node, then click **Global 1**.
- 2 In the **Settings** window for **Global**, locate the **y-Axis Data** section.
- 3 In the table, enter the following settings:

| Expression | Unit | Description          |
|------------|------|----------------------|
| ts         |      | Center time estimate |

#### *Table Graph 1*

- 1 In the **Model Builder** window, click **Table Graph 1**.
- 2 In the **Settings** window for **Table Graph**, locate the **Data** section.
- 3 In the **Columns** list box, select **ts (s)**.

4 In the **Center Time** toolbar, click  **Plot**.

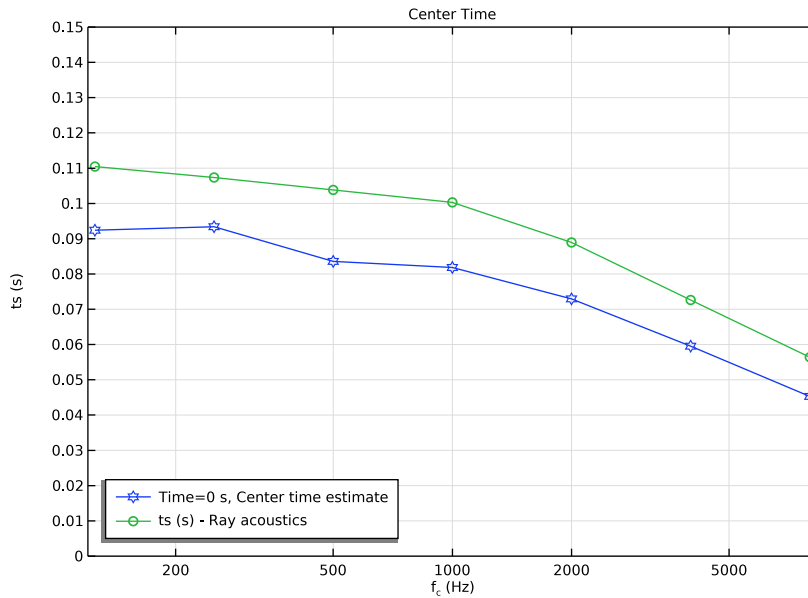

### Reverberation Times

- 1 In the **Model Builder** window, right-click **Center Time** and choose **Duplicate**.
- 2 In the **Settings** window for **ID Plot Group**, type Reverberation Times in the **Label** text field.
- 3 Locate the **Plot Settings** section. In the **y-axis label** text field, type RT (s).
- 4 Locate the **Axis** section. In the **x minimum** text field, type 120.
- 5 In the **x maximum** text field, type 8322.
- 6 In the **y minimum** text field, type 0.
- 7 In the **y maximum** text field, type 1.6.

### Global I

- 1 In the **Model Builder** window, expand the **Reverberation Times** node.
- 2 Right-click **Global I** and choose **Delete**.

### Table Graph I

- 1 In the **Settings** window for **Table Graph**, locate the **Data** section.
- 2 In the **Columns** list, choose **EDT (s)**, **T20 (s)**, **T30 (s)**, and **T60 (s)**.

- 3 In the **Reverberation Times** toolbar, click  **Plot**.  
This should reproduce the third image in [Figure 10](#).

#### *Speech Transmission Index*

- 1 In the **Model Builder** window, right-click **Reverberation Times** and choose **Duplicate**.
- 2 In the **Settings** window for **ID Plot Group**, type **Speech Transmission Index** in the **Label** text field.
- 3 Locate the **Plot Settings** section. In the **y-axis label** text field, type **STI (1)**.
- 4 Locate the **Axis** section. In the **x minimum** text field, type **120**.
- 5 In the **x maximum** text field, type **8322**.
- 6 In the **y minimum** text field, type **0**.
- 7 In the **y maximum** text field, type **1**.
- 8 Locate the **Legend** section. From the **Position** list, choose **Upper left**.

#### *Table Graph 1*

- 1 In the **Model Builder** window, expand the **Speech Transmission Index** node, then click **Table Graph 1**.
- 2 In the **Settings** window for **Table Graph**, locate the **Data** section.
- 3 In the **Columns** list box, select **STI (1)**.
- 4 In the **Speech Transmission Index** toolbar, click  **Plot**.  
This should reproduce the fourth image in [Figure 10](#).

#### *Center Time, Clarity, Definition, Reverberation Times, Speech Transmission Index*

- 1 In the **Model Builder** window, under **Results**, Ctrl-click to select **Definition**, **Clarity**, **Center Time**, **Reverberation Times**, and **Speech Transmission Index**.
- 2 Right-click and choose **Group**.

#### *Objective Quality Metric Plots*

In the **Settings** window for **Group**, type **Objective Quality Metric Plots** in the **Label** text field.

Next, solve the model with the directional loudspeaker using a parametric sweep that fits the frequency range of the speaker data.

#### **ADD STUDY**

- 1 In the **Home** toolbar, click  **Add Study** to open the **Add Study** window.
- 2 Go to the **Add Study** window.

- 3 Find the **Studies** subsection. In the **Select Study** tree, select **Preset Studies for Selected Physics Interfaces > Ray Tracing**.
- 4 Click the **Add Study** button in the window toolbar.
- 5 In the **Home** toolbar, click  **Add Study** to close the **Add Study** window.



## STUDY 2 - DIRECTIONAL LOUDSPEAKER

In the **Settings** window for **Study**, type Study 2 - Directional Loudspeaker in the **Label** text field.



### Step 1: Ray Tracing

- 1 In the **Model Builder** window, under **Study 2 - Directional Loudspeaker** click **Step 1: Ray Tracing**.
- 2 In the **Settings** window for **Ray Tracing**, locate the **Study Settings** section.
- 3 From the **Time unit** list, choose **s**.
- 4 In the **Output times** text field, type 0 1.6.
- 5 Locate the **Physics and Variables Selection** section. Select the **Modify model configuration for study step** checkbox.
- 6 In the tree, select **Component 1 (comp1) > Ray Acoustics (rac) > Source with Directivity 1**.
- 7 Click  **Disable**.

### Parametric Sweep

- 1 In the **Study** toolbar, click  **Parametric Sweep**.
- 2 In the **Settings** window for **Parametric Sweep**, locate the **Study Settings** section.
- 3 Click  **Add**.
- 4 In the table, enter the following settings:

| Parameter name             | Parameter value list | Parameter unit |
|----------------------------|----------------------|----------------|
| f0 (Band center frequency) |                      | Hz             |

- 5 In the table, click to select the cell at row number 1 and column number 2.
- 6 Click  **Range**.
- 7 In the **Range** dialog, choose **ISO preferred frequencies** from the **Entry method** list.
- 8 In the **Start frequency** text field, type 63.
- 9 In the **Stop frequency** text field, type 4000.
- 10 Click **Replace**.
- 11 In the **Study** toolbar, click  **Compute**.

## RESULTS

### *Ray Trajectories (rac) I*

- 1 In the **Settings** window for **3D Plot Group**, locate the **Data** section.
- 2 From the **Time (s)** list, choose **Interpolation**.
- 3 In the **Time** text field, type 1 [ms].

### *Ray Trajectories I*

- 1 In the **Model Builder** window, expand the **Ray Trajectories (rac) I** node, then click **Ray Trajectories I**.
- 2 In the **Settings** window for **Ray Trajectories**, locate the **Coloring and Style** section.
- 3 Find the **Line style** subsection. From the **Type** list, choose **None**.
- 4 Find the **Point style** subsection. From the **Type** list, choose **Point**.

### *Color Expression I*

- 1 In the **Model Builder** window, expand the **Ray Trajectories I** node, then click **Color Expression I**.
- 2 In the **Settings** window for **Color Expression**, locate the **Expression** section.
- 3 In the **Expression** text field, type `rac.Lp`.
- 4 In the **Ray Trajectories (rac) I** toolbar, click  **Plot**.  
This should reproduce the image in [Figure 12](#).

### *Loudspeaker Orientation*

- 1 In the **Home** toolbar, click  **Add Plot Group** and choose **3D Plot Group**.
- 2 In the **Settings** window for **3D Plot Group**, type Loudspeaker Orientation in the **Label** text field.
- 3 Locate the **Data** section. From the **Dataset** list, choose **Study 2 - Directional Loudspeaker/ Solution 10 (sol10)**.
- 4 Click to expand the **Selection** section. From the **Geometric entity level** list, choose **Point**.
- 5 Select Point 11 only.

### *Coordinate System Point I*

- 1 In the **Loudspeaker Orientation** toolbar, click  **More Plots** and choose **Coordinate System Point**.
- 2 In the **Settings** window for **Coordinate System Point**, locate the **Coordinate System** section.
- 3 From the **Coordinate system** list, choose **Rotated System 2 (sys2)**.

- 4 Locate the **Coloring and Style** section.
- 5 Select the **Scale factor** checkbox. In the associated text field, type 2.
- 6 In the **Loudspeaker Orientation** toolbar, click  **Plot**.

This should reproduce the image in [Figure 11](#).

#### *Seats SPL 1*

- 1 In the **Model Builder** window, right-click **Seats SPL** and choose **Duplicate**.
- 2 In the **Settings** window for **3D Plot Group**, locate the **Data** section.
- 3 From the **Dataset** list, choose **Study 2 - Directional Loudspeaker/ Parametric Solutions 2 (sol 1)**.
- 4 In the **Seats SPL 1** toolbar, click  **Plot**.

This should reproduce the image in [Figure 13](#).

### *Geometry Modeling Instructions*

---

From the **File** menu, choose **New**.

#### **NEW**





In the **New** window, click  **Blank Model**.

#### **ADD COMPONENT**

In the **Home** toolbar, click  **Add Component** and choose **3D**.

#### **GEOMETRY 1**



##### *Import 1 (imp1)*

- 1 In the **Geometry** toolbar, click  **Import**.
- 2 In the **Settings** window for **Import**, locate the **Source** section.
- 3 Click  **Browse**.
- 4 Browse to the model's Application Libraries folder and double-click the file `small_concert_hall.mphbin`.
- 5 Click  **Import**.
- 6 Click the  **Wireframe Rendering** button in the **Graphics** toolbar.

##### *Delete Entities 1 (del1)*

- 1 In the **Model Builder** window, right-click **Geometry 1** and choose **Delete Entities**.
- 2 On the object **imp1**, select Boundary 40 only.

### *Extrude 1 (ext1)*

- 1 In the **Geometry** toolbar, click  **Extrude**.
- 2 On the object **del1**, select Boundary 39 only.
- 3 In the **Settings** window for **Extrude**, locate the **Distances** section.
- 4 Select the **Reverse direction** checkbox.
- 5 Click  **Build Selected**.

### *Delete Entities 2 (del2)*

- 1 Right-click **Geometry 1** and choose **Delete Entities**.
- 2 On the object **ext1**, select Boundary 41 only.

### *Windows*

- 1 In the **Geometry** toolbar, click  **Selections** and choose **Explicit Selection**.
- 2 In the **Settings** window for **Explicit Selection**, type Windows in the **Label** text field.
- 3 Locate the **Entities to Select** section. From the **Geometric entity level** list, choose **Boundary**.
- 4 On the object **del2**, select Boundaries 63–65 only.

### *Seats*

- 1 In the **Geometry** toolbar, click  **Selections** and choose **Explicit Selection**.
- 2 In the **Settings** window for **Explicit Selection**, type Seats in the **Label** text field.
- 3 Locate the **Entities to Select** section. From the **Geometric entity level** list, choose **Boundary**.
- 4 On the object **del2**, select Boundaries 39–42 and 59 only.

### *Diffusers*

- 1 In the **Geometry** toolbar, click  **Selections** and choose **Explicit Selection**.
- 2 In the **Settings** window for **Explicit Selection**, type Diffusers in the **Label** text field.
- 3 Locate the **Entities to Select** section. From the **Geometric entity level** list, choose **Boundary**.
- 4 On the object **del2**, select Boundaries 13, 15, 29, 30, 43, 44, 51, and 52 only.

### *Floor*

- 1 In the **Geometry** toolbar, click  **Selections** and choose **Explicit Selection**.
- 2 In the **Settings** window for **Explicit Selection**, type Floor in the **Label** text field.
- 3 Locate the **Entities to Select** section. From the **Geometric entity level** list, choose **Boundary**.

4 On the object **del2**, select Boundaries 3, 8, 12, 14, 18, and 21 only.

#### *Entrance*

- 1 In the **Geometry** toolbar, click  **Selections** and choose **Explicit Selection**.
- 2 In the **Settings** window for **Explicit Selection**, type Entrance in the **Label** text field.
- 3 Locate the **Entities to Select** section. From the **Geometric entity level** list, choose **Boundary**.
- 4 On the object **del2**, select Boundaries 16, 19, 20, 23, 31, and 32 only.

#### *Walls*

- 1 In the **Geometry** toolbar, click  **Selections** and choose **Explicit Selection**.
- 2 In the **Settings** window for **Explicit Selection**, type Walls in the **Label** text field.
- 3 Locate the **Entities to Select** section. From the **Geometric entity level** list, choose **Boundary**.
- 4 On the object **del2**, select Boundaries 1, 2, 4–7, 9–11, 17, 22, 24–28, 34–37, 45–50, 53–58, and 60–62 only.

#### *Absorbers*

- 1 In the **Geometry** toolbar, click  **Selections** and choose **Explicit Selection**.
- 2 In the **Settings** window for **Explicit Selection**, type Absorbers in the **Label** text field.
- 3 Locate the **Entities to Select** section. From the **Geometric entity level** list, choose **Boundary**.
- 4 On the object **del2**, select Boundaries 33 and 38 only.

#### *Form Union (fin)*

- 1 In the **Model Builder** window, click **Form Union (fin)**.

2 In the **Settings** window for **Form Union/Assembly**, click  **Build Selected**.

