



Model created in COMSOL Multiphysics 6.4

# Piezoelectric MEMS Speaker

## Introduction

---

This model analyzes a piezoelectric microelectromechanical system (MEMS) speaker presented in Ref. 1, 2, and 3. The speaker, composed of four triangular membranes, uses a layer of lead zirconate titanate (PZT) material with two electrodes on opposing faces as actuator. The triangular membranes are separated by narrow gaps of air that allow for larger deflections of the membrane. The thermoviscous losses in the gaps limit the airflow, thus allowing the four actuators to behave acoustically as a single membrane.

## Model Definition

---

The PZT material, which seats on top of a silicon layer, is excited with a voltage that makes the membrane move and create sound. Figure 1 shows a schematic view of the speaker. The four triangular membranes are separated by narrow gaps of air. The acoustic behavior in the gaps (shown in green) is modeled with the full thermoviscous acoustic formulation using the *Thermoviscous Acoustics, Frequency Domain* physics interface.

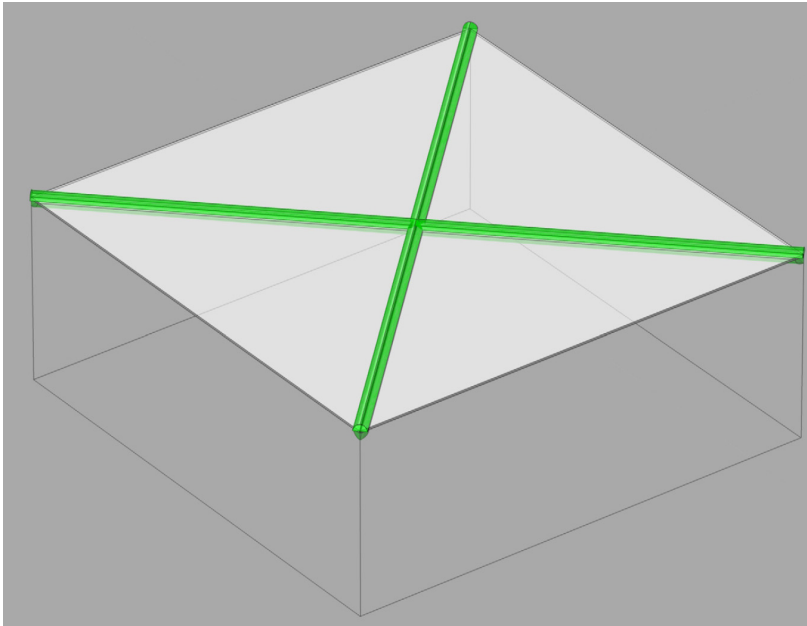


Figure 1: Schematic representation of the piezoelectric MEMS speaker, with the areas where thermoviscous losses are relevant highlighted in green.

The four triangular membranes form a square with approximately 4 mm sides. The membrane is backed by a back volume of roughly 24 mm<sup>3</sup>. The volume acts as a spring (compliance) changing the acoustic properties of the speaker.

The tutorial takes advantage of the existing symmetries to model only a quarter of the speaker and represent the rest by using symmetry features. The speaker is located in an infinite baffle and uses a voltage difference acting between the faces of the PZT material to create vibrations that will propagate as acoustic perturbations. The acting voltage contains a constant component, usually called the bias voltage (DC) and an alternating voltage (AC or perturbation contribution), following

$$V_0 = V_{DC} + V_{AC} \cos(2\pi f \cdot t) \quad (1)$$

where  $V_0$  is the terminal voltage,  $V_{DC}$  is the bias voltage,  $V_{AC}$  is the alternating voltage,  $f$  is the driving frequency, and  $t$  is the time. Due to the piezoelectric effect, the PZT material excited with this voltage will induce deformations in the membranes. The piezoelectric material and structures are modeled with the *Solid Mechanics* and the *Electrostatics* physics interfaces, coupled with the *Piezoelectric Effect* multiphysics coupling and associated material models.

The air gap between the membranes is 9 μm wide, and this gap is in the order of magnitude of the viscous boundary layer in air (at the frequencies studied here). The boundary layer thickness is given by

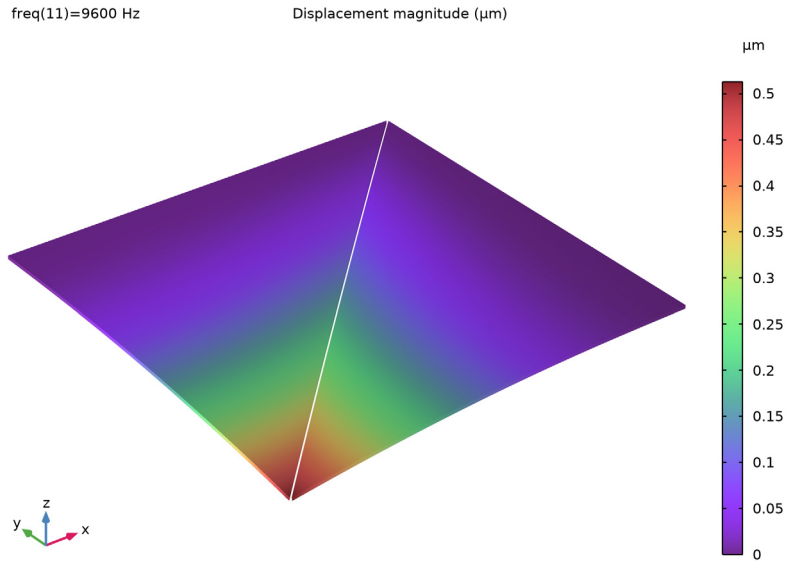
$$\delta_v = \sqrt{\frac{2\mu}{\omega\rho}} = 0.22 \text{ mm} \cdot \sqrt{\frac{100 \text{ Hz}}{f}} \quad (2)$$

where  $\delta_v$  is the viscous boundary layer thickness (in the second equation the material properties of air have been entered). At the resonance frequency of 9 kHz,  $\delta_v$  takes the value of 23.2 μm, on the same order of magnitude as the gap. This indicates that the thermoviscous losses are likely to modify the response of the speaker at the driving frequency. To capture the losses, the *Thermoviscous Acoustics, Frequency Domain* is used to model the acoustics in the air gaps and a small surrounding volume.

The rest of the acoustic domains are captured using the *Pressure Acoustics, Frequency Domain* physics interface. Here the thermoviscous boundary layers are captured through the *Thermoviscous Boundary Layer Impedance* boundary condition. The open domain conditions surrounding the speaker is modeled with a *Perfectly Matched Layer*. The *Exterior Field Calculation* feature is used to obtain the acoustic field at any point in the exterior domain.

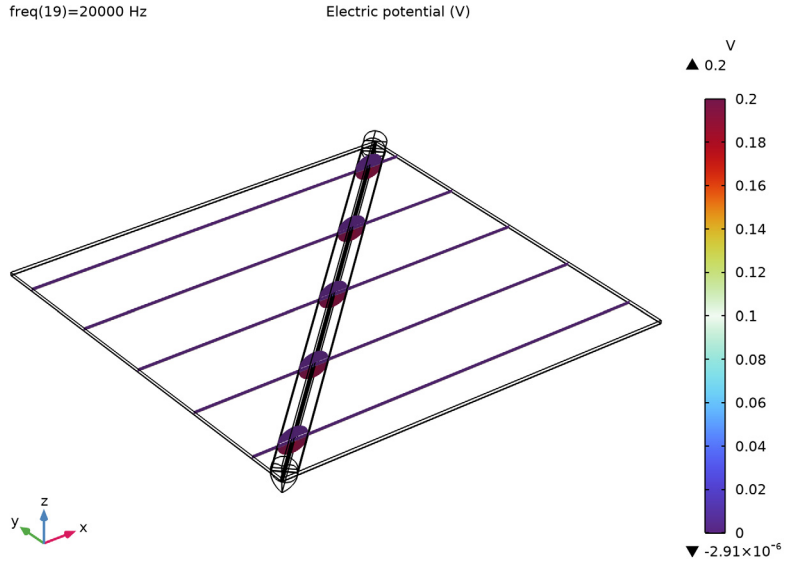
## Results and Discussion

The harmonic component of the displacement of the membrane is shown in [Figure 2](#). Note how the excitation produces displacement perpendicular to the plane of the membrane through bending.

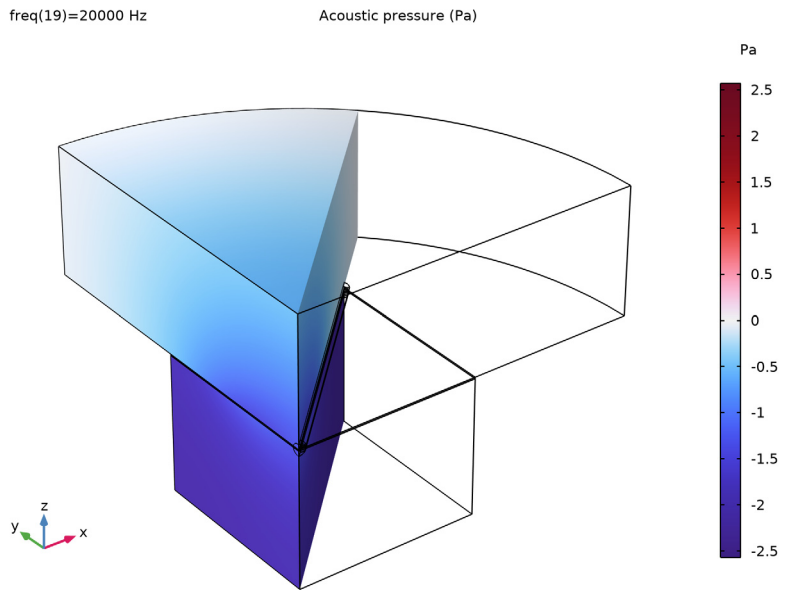


*Figure 2: Harmonic part of the displacement magnitude at the membranes.*

[Figure 3](#) shows the distribution of the electric potential in the membranes. The electric potential variation takes place almost exclusively in the vertical direction. As seen in [Figure 4](#), the small dimensions of the speaker means that the computational domain does not even capture a full wavelength at the highest frequency analyzed, 20 kHz.



*Figure 3: Harmonic variation of the electric potential.*



*Figure 4: Total acoustic pressure at 20 kHz.*

Figure 5 shows the instantaneous acoustic velocity around the air gaps. The high velocity gradients present in the air gaps create viscous shear losses that damp the natural frequency of the membranes. Note that the section shown is close to the center of the membrane, so the complete section has a velocity larger than 0.

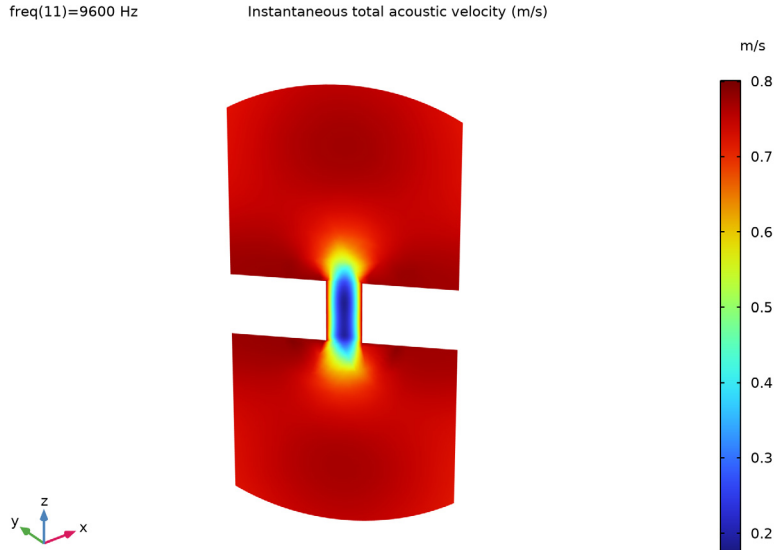
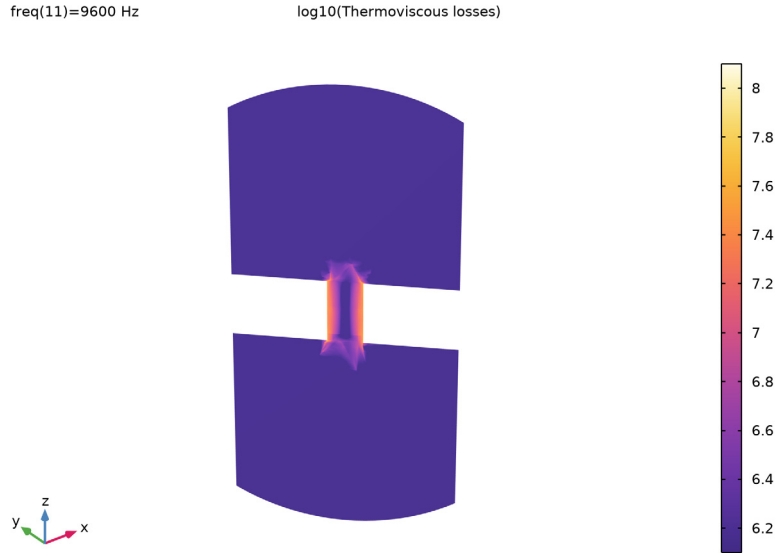


Figure 5: Instantaneous local velocity at 9 kHz.

The logarithmic thermoviscous losses, shown in Figure 6 demonstrate how most of the thermoviscous losses are concentrated in the air gap, suggesting that a *Narrow Region Acoustics* feature (using the slit option) in *Pressure Acoustics* could potentially be enough to capture the losses caused by the air gap. This requires that the gap is not significantly modified during operation. This is discussed further in the [Notes About the COMSOL Implementation](#) section below.



*Figure 6: Logarithmic volumetric thermoviscous losses around the air gap.*

Figure 7 shows the magnitude and phase of the electric impedance of the speaker. The electric impedance shows excellent agreement with the experimental results in Ref. 1, 2, and 3.

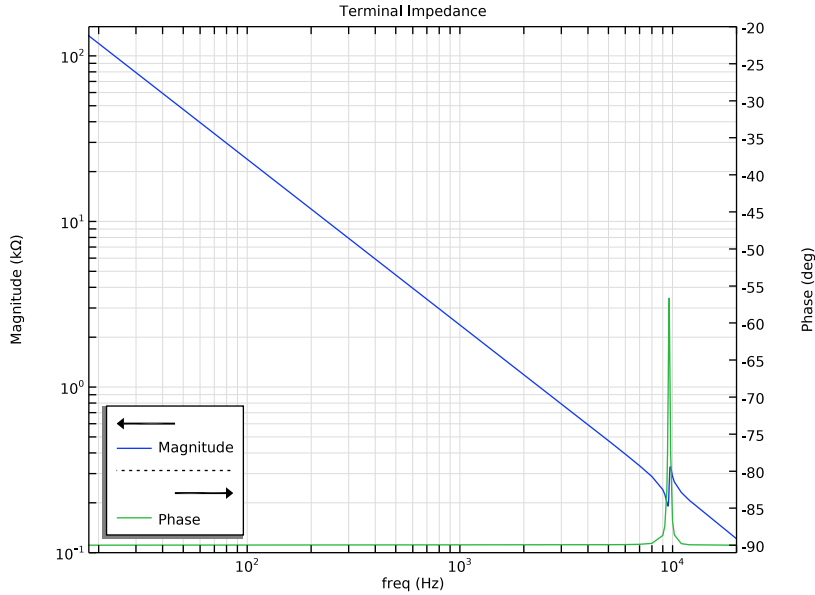
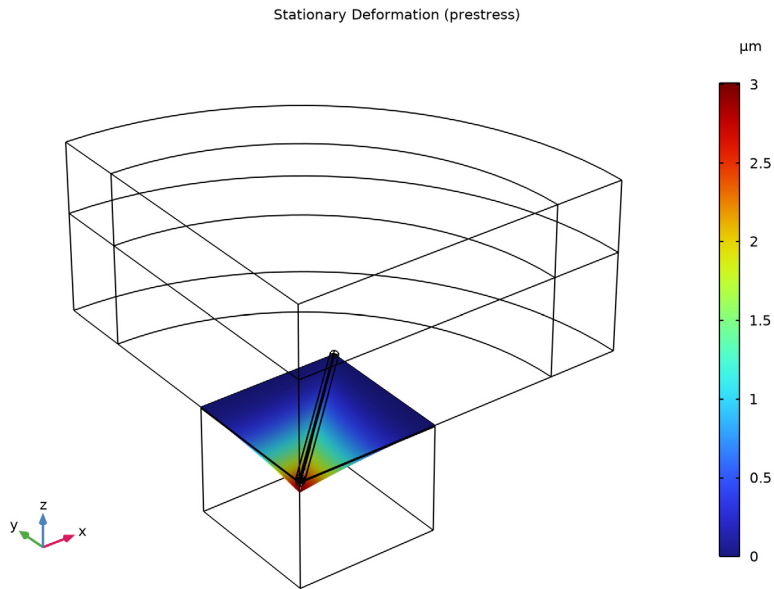


Figure 7: Electric impedance of the speaker, magnitude and phase.

### Notes About the COMSOL Implementation

The model uses the *Small-Signal Analysis* to analyze the static effect of the bias voltage and the harmonic perturbation caused by the alternating voltage. To include the effects of the DC part (prestress and deformation) it is important that the **Include geometric nonlinearity** is selected in the **Frequency Domain Perturbation** study step.

The model is solved in the frequency domain which assumes small deformations (small signal assumption). This means that, for example, topological changes of the air gap are not captured (the gap effectively remains the same) in the simulation. This is an assumption made when working in the frequency domain. At the resonance the maximum deflection is a bout 4  $\mu\text{m}$  which is on top of the static DC deformation of about 3  $\mu\text{m}$ , see [Figure 8](#). The gap width is 9  $\mu\text{m}$  and the gap height is 17  $\mu\text{m}$ , so at resonance the small signal assumption is probably not fully valid. The topological changes can be included in the model by using the **Moving Mesh** functionality. Including the dynamic topology changes on top of the DC deformation requires solving a transient model.



*Figure 8: Stationary deformation of the membrane due to the DC bias voltage.*

The model uses the **Added Mass** feature under Solid Mechanics to represent the masses of the electrodes, which have a significant effect on the resonance frequencies.

### *References*

- 
1. F. Stoppel, A.Männchen, F. Niekel, D. Beer, T. Giese, and B. Wagner, “New integrated full-range MEMS speaker for in-ear applications,” *IEEE Micro Electro Mechanical Systems (MEMS)*, 2018.
  2. A.Männchen, F. Stoppel, D. Beer, F. Niekel, and B. Wagner, “In-ear headphone system with piezoelectric MEMS driver,” *Audio Engineering Society*, 2018.
  3. A.Männchen, F. Stoppel, T. Brocks, F. Niekel, D. Beer, and B. Wagner, “Design and electroacoustic analysis of a piezoelectric MEMS in-ear headphone,” *Audio Engineering Society*, 2018.

---

**Application Library path:** Acoustics\_Module/Electroacoustic\_Transducers/  
piezo\_mems\_speaker


---

### *Modeling Instructions*




---

From the **File** menu, choose **New**.

#### **NEW**

In the **New** window, click  **Model Wizard**.

#### **MODEL WIZARD**

- 1 In the **Model Wizard** window, click  **3D**.
- 2 In the **Select Physics** tree, select **Structural Mechanics > Electromagnetics–Structure Interaction > Piezoelectricity > Piezoelectricity, Solid**.
- 3 Click **Add**.
- 4 In the **Select Physics** tree, select **Acoustics > Pressure Acoustics > Pressure Acoustics, Frequency Domain (acpr)**.
- 5 Click **Add**.
- 6 In the **Select Physics** tree, select **Acoustics > Thermoviscous Acoustics > Thermoviscous Acoustics, Frequency Domain (ta)**.
- 7 Click **Add**.
- 8 Click  **Study**.
- 9 In the **Select Study** tree, select **Preset Studies for Selected Physics Interfaces > Electrostatics > Small-Signal Analysis, Frequency Domain**.
- 10 Click  **Done**.

#### **GEOMETRY I**


Adjust the units of the model to  $\mu\text{m}$ .

- 1 In the **Model Builder** window, under **Component 1 (comp1)** click **Geometry 1**.
- 2 In the **Settings** window for **Geometry**, locate the **Units** section.
- 3 From the **Length unit** list, choose  **$\mu\text{m}$** .

Import the parameters from an external file. This file contains parameters like dimensions, maximum frequency and voltage that define the current model.




## GLOBAL DEFINITIONS

### *Parameters 1*

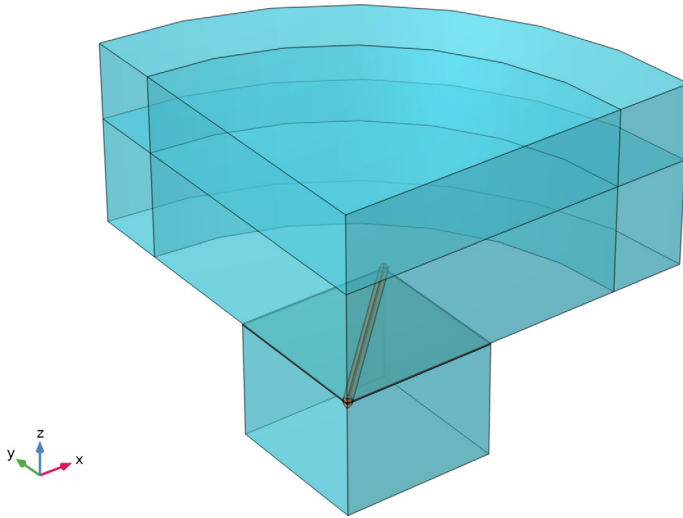
- 1 In the **Model Builder** window, under **Global Definitions** click **Parameters 1**.
- 2 In the **Settings** window for **Parameters**, locate the **Parameters** section.
- 3 Click  **Load from File**.
- 4 Browse to the model's Application Libraries folder and double-click the file `piezo_mems_speaker_parameters.txt`.


Import the geometry from an external file.

## GEOMETRY 1

- 1 In the **Geometry** toolbar, click **Insert Sequence** and choose **Insert Sequence 1**.
- 2 Browse to the model's Application Libraries folder and double-click the file `piezo_mems_speaker_geom_sequence.mph`.
- 3 In the **Geometry** toolbar, click  **Build All**.
- 4 Click the  **Show Grid** button in the **Graphics** toolbar.
- 5 Click the  **Transparency** button in the **Graphics** toolbar.  
The picture should like this.

6 In the **Model Builder** window, under **Component 1 (comp1)** click **Geometry 1**.



7 Click the  **Transparency** button in the **Graphics** toolbar.

## DEFINITIONS

### *Linear Extrusion 1 (linext1)*

1 In the **Definitions** toolbar, click  **Nonlocal Couplings** and choose **Linear Extrusion**.

Add a **Linear Extrusion** feature for use when generating result plots later on.

2 In the **Settings** window for **Linear Extrusion**, locate the **Source Selection** section.

3 From the **Geometric entity level** list, choose **Edge**.

4 Select Edges 36, 91, and 141 only.

5 Locate the **Source Vertices** section. Click to select the  **Activate Selection** toggle button.

6 Select Point 11 only.

7 Click to select the  **Activate Selection** toggle button.

8 Select Point 65 only.

9 Locate the **Destination Vertices** section. Click to select the  **Activate Selection** toggle button.

10 Select Point 11 only.

11 Click to select the  **Activate Selection** toggle button.

12 Select Point 65 only.

*Perfectly Matched Layer 1 (pml1)*

1 In the **Definitions** toolbar, click  **Perfectly Matched Layer**.

2 In the **Settings** window for **Perfectly Matched Layer**, locate the **Domain Selection** section.

3 From the **Selection** list, choose **PML Domains**.

4 Locate the **Geometry** section. From the **Type** list, choose **Cylindrical**.

5 Locate the **Scaling** section. From the **Physics** list, choose **Pressure Acoustics, Frequency Domain (acpr)**.

## GEOMETRY 1

In the **Model Builder** window, collapse the **Component 1 (comp1) > Geometry 1** node.

## MATERIALS

Apply materials to the model. Use the Air and Silicon materials from the Built-in category and the PZT material from the Piezoelectric category.

## ADD MATERIAL

1 In the **Materials** toolbar, click  **Add Material** to open the **Add Material** window.

2 Go to the **Add Material** window.

3 In the tree, select **Built-in > Air**.

4 Click the **Add to Component** button in the window toolbar.

5 In the tree, select **Piezoelectric > Lead Zirconate Titanate (PZT-4)**.

6 Click the **Add to Component** button in the window toolbar.

7 In the tree, select **Built-in > Silicon**.

8 Click the **Add to Component** button in the window toolbar.

9 In the **Materials** toolbar, click  **Add Material** to close the **Add Material** window.

## MATERIALS

*Silicon (mat3)*

1 In the **Settings** window for **Material**, locate the **Geometric Entity Selection** section.

2 From the **Selection** list, choose **Silicon Domains**.

#### *Lead Zirconate Titanate (PZT-4) (mat2)*

- 1 In the **Model Builder** window, click **Lead Zirconate Titanate (PZT-4) (mat2)**.
- 2 In the **Settings** window for **Material**, locate the **Geometric Entity Selection** section.
- 3 From the **Selection** list, choose **PZT Domains**.

#### *Air (mat1)*

- 1 In the **Model Builder** window, click **Air (mat1)**.
- 2 In the **Settings** window for **Material**, locate the **Geometric Entity Selection** section.
- 3 From the **Selection** list, choose **Air Domains**.

#### **SOLID MECHANICS (SOLID)**



- 1 In the **Model Builder** window, under **Component 1 (comp1)** click **Solid Mechanics (solid)**.
- 2 In the **Settings** window for **Solid Mechanics**, locate the **Domain Selection** section.
- 3 From the **Selection** list, choose **Structural Domains**.

Add the **Piezoelectric Material** feature to the PZT domain so the piezoelectric forces are computed correctly.


#### *Piezoelectric Material 1*

- 1 In the **Model Builder** window, under **Component 1 (comp1)** > **Solid Mechanics (solid)** click **Piezoelectric Material 1**.
- 2 In the **Settings** window for **Piezoelectric Material**, locate the **Domain Selection** section.
- 3 From the **Selection** list, choose **PZT Domains**.

#### *Fixed Constraint 1*


- 1 In the **Physics** toolbar, click  **Boundaries** and choose **Fixed Constraint**.
- 2 In the **Settings** window for **Fixed Constraint**, locate the **Boundary Selection** section.
- 3 Click  **Clear Selection**.
- 4 Select Boundaries 45, 46, 111, 113, 142–144, and 146 only.

#### *Symmetry 1*


- 1 In the **Physics** toolbar, click  **Boundaries** and choose **Symmetry**.
- 2 In the **Settings** window for **Symmetry**, locate the **Boundary Selection** section.
- 3 From the **Selection** list, choose **Symmetric Boundaries**.

Add the mass representing the electrodes as this mass influences the eigenfrequencies of the system.

#### *Added Mass - Pt Electrode*

- 1 In the **Physics** toolbar, click  **Boundaries** and choose **Added Mass**.
- 2 In the **Settings** window for **Added Mass**, type Added Mass - Pt Electrode in the **Label** text field.
- 3 Locate the **Boundary Selection** section. From the **Selection** list, choose **Ground**.
- 4 Locate the **Added Mass** section. In the  $\rho_A$  text field, type rho\_pt\*th\_pt.

#### *Added Mass - Au Electrode*

- 1 In the **Physics** toolbar, click  **Boundaries** and choose **Added Mass**.
- 2 In the **Settings** window for **Added Mass**, type Added Mass - Au Electrode in the **Label** text field.
- 3 Locate the **Boundary Selection** section. From the **Selection** list, choose **Terminal**.
- 4 Locate the **Added Mass** section. In the  $\rho_A$  text field, type rho\_au\*th\_au.

To reduce the computation time of the model, only model the electrostatics effects in the membrane and the air around the gap.


### **ELECTROSTATICS (ES)**

- 1 In the **Model Builder** window, under **Component 1 (comp1)** click **Electrostatics (es)**.
- 2 In the **Settings** window for **Electrostatics**, locate the **Domain Selection** section.
- 3 From the **Selection** list, choose **Electrostatics Domains**.


#### *Charge Conservation, Piezoelectric I*

- 1 In the **Model Builder** window, under **Component 1 (comp1)** > **Electrostatics (es)** click **Charge Conservation, Piezoelectric I**.
- 2 In the **Settings** window for **Charge Conservation, Piezoelectric**, locate the **Domain Selection** section.
- 3 From the **Selection** list, choose **PZT Domains**.

#### *Charge Conservation in Solids I*


- 1 In the **Physics** toolbar, click  **Domains** and choose **Charge Conservation in Solids**.
- 2 In the **Settings** window for **Charge Conservation in Solids**, locate the **Domain Selection** section.
- 3 From the **Selection** list, choose **Silicon Domains**.

#### *Ground I*

- 1 In the **Physics** toolbar, click  **Boundaries** and choose **Ground**.
- 2 In the **Settings** window for **Ground**, locate the **Boundary Selection** section.

- 3 From the **Selection** list, choose **Ground**.

#### *Boundary Terminal 1*


- 1 In the **Physics** toolbar, click  **Boundaries** and choose **Boundary Terminal**.
- 2 In the **Settings** window for **Boundary Terminal**, locate the **Boundary Selection** section.
- 3 From the **Selection** list, choose **Terminal**.
- 4 Locate the **Terminal** section. From the **Terminal type** list, choose **Voltage**.
- 5 In the  $V_0$  text field, type  $V_{DC} + \text{linper}(V_{AC})$ .

The speaker has a bias voltage that will be considered in the **Stationary** step of the analysis. Use the `linper` operator to discern the variable part of the voltage that will be used in the **Frequency Domain Perturbation** step.


### **PRESSURE ACOUSTICS, FREQUENCY DOMAIN (ACPR)**

- 1 In the **Model Builder** window, under **Component 1 (comp1)** click **Pressure Acoustics, Frequency Domain (acpr)**.
- 2 In the **Settings** window for **Pressure Acoustics, Frequency Domain**, locate the **Domain Selection** section.
- 3 From the **Selection** list, choose **Pressure Acoustics Domains**.
- 4 Click to expand the **Discretization** section.


#### *Symmetry 1*

- 1 In the **Physics** toolbar, click  **Boundaries** and choose **Symmetry**.
- 2 In the **Settings** window for **Symmetry**, locate the **Boundary Selection** section.
- 3 From the **Selection** list, choose **Symmetric Boundaries**.

#### *Exterior Field Calculation 1*

- 1 In the **Physics** toolbar, click  **Boundaries** and choose **Exterior Field Calculation**.
- 2 In the **Settings** window for **Exterior Field Calculation**, locate the **Boundary Selection** section.
- 3 From the **Selection** list, choose **Exterior Field Boundaries**.
- 4 Locate the **Exterior Field Calculation** section. From the **Condition in the  $x = x_0$  plane** list, choose **Symmetric/Infinite sound hard boundary**.
- 5 From the **Condition in the  $y = y_0$  plane** list, choose **Symmetric/Infinite sound hard boundary**.
- 6 From the **Condition in the  $z = z_0$  plane** list, choose **Symmetric/Infinite sound hard boundary**.


### *Thermoviscous Boundary Layer Impedance 1*

- 1 In the **Physics** toolbar, click  **Boundaries** and choose **Thermoviscous Boundary Layer Impedance**.
- 2 In the **Settings** window for **Thermoviscous Boundary Layer Impedance**, locate the **Fluid Properties** section.
- 3 From the **Fluid material** list, choose **Air (mat1)**.
- 4 Select Boundaries 3, 44, 47, and 141 only.

### **THERMOVISCOUS ACOUSTICS, FREQUENCY DOMAIN (TA)**

- 1 In the **Model Builder** window, under **Component 1 (comp1)** click **Thermoviscous Acoustics, Frequency Domain (ta)**.
- 2 In the **Settings** window for **Thermoviscous Acoustics, Frequency Domain**, locate the **Domain Selection** section.
- 3 From the **Selection** list, choose **Thermoviscous Domains**.


### *Symmetry 1*

- 1 In the **Physics** toolbar, click  **Boundaries** and choose **Symmetry**.
- 2 In the **Settings** window for **Symmetry**, locate the **Boundary Selection** section.
- 3 From the **Selection** list, choose **Symmetric Boundaries**.


Add the missing multiphysics couplings that will handle the interaction between the different physics. Thermoviscous acoustics to the structure, pressure acoustics to the structure, and the coupling between thermoviscous acoustics and pressure acoustics.

### **MULTIPHYSICS**

#### *Thermoviscous Acoustic–Structure Boundary 1 (tsb1)*


- 1 In the **Physics** toolbar, click  **Multiphysics Couplings** and choose **Boundary > Thermoviscous Acoustic–Structure Boundary**.
- 2 In the **Settings** window for **Thermoviscous Acoustic–Structure Boundary**, locate the **Boundary Selection** section.
- 3 From the **Selection** list, choose **All boundaries**.

#### *Acoustic–Thermoviscous Acoustic Boundary 1 (atb1)*

- 1 In the **Physics** toolbar, click  **Multiphysics Couplings** and choose **Boundary > Acoustic–Thermoviscous Acoustic Boundary**.
- 2 In the **Settings** window for **Acoustic–Thermoviscous Acoustic Boundary**, locate the **Boundary Selection** section.

3 From the **Selection** list, choose **All boundaries**.

#### *Acoustic–Structure Boundary 1 (asb1)*

1 In the **Physics** toolbar, click  **Multiphysics Couplings** and choose **Boundary > Acoustic–Structure Boundary**.

2 In the **Settings** window for **Acoustic–Structure Boundary**, locate the **Boundary Selection** section.

3 From the **Selection** list, choose **All boundaries**.

The thermoviscous boundary layer impedance includes the viscous and thermal losses in the thin boundary layers.

#### *Thermoviscous Boundary Layer Impedance 1 (tvb1)*

1 In the **Physics** toolbar, click  **Attributes** and choose **Thermoviscous Boundary Layer Impedance**.

2 In the **Settings** window for **Thermoviscous Boundary Layer Impedance**, locate the **Boundary Selection** section.

3 From the **Selection** list, choose **All Boundaries**.

4 Locate the **Fluid Properties** section. From the **Fluid material** list, choose **Air (mat1)**.

## **MESH 1**

In this model, the mesh is set up manually. Proceed by directly adding the desired mesh component.

#### *Mapped 1*

1 In the **Mesh** toolbar, click  **More Generators** and choose **Mapped**.

2 Click the  **Wireframe Rendering** button in the **Graphics** toolbar.

3 Select Boundaries 36, 73, 81, 90, and 121 only.

4 In the **Settings** window for **Mapped**, click to expand the **Reduce Element Skewness** section.

5 Select the **Adjust edge mesh** checkbox.

#### *Size 1*

1 Right-click **Mapped 1** and choose **Size**.

2 In the **Settings** window for **Size**, locate the **Element Size** section.

3 Click the **Custom** button.

4 Locate the **Element Size Parameters** section.

5 Select the **Maximum element size** checkbox. In the associated text field, type  $d_{\text{visc}}*4$ .

#### *Distribution 1*

- 1 In the **Model Builder** window, right-click **Mapped 1** and choose **Distribution**.
- 2 Select Edge 35 only.
- 3 In the **Settings** window for **Distribution**, locate the **Distribution** section.
- 4 From the **Distribution type** list, choose **Predefined**.
- 5 In the **Element ratio** text field, type 2.
- 6 Select the **Symmetric distribution** checkbox.

#### *Distribution 2*

- 1 Right-click **Mapped 1** and choose **Distribution**.
- 2 Select Edge 102 only.
- 3 In the **Settings** window for **Distribution**, locate the **Distribution** section.
- 4 From the **Distribution type** list, choose **Predefined**.
- 5 In the **Element ratio** text field, type 3.

#### *Distribution 3*

- 1 Right-click **Mapped 1** and choose **Distribution**.
- 2 Select Edge 81 only.
- 3 In the **Settings** window for **Distribution**, locate the **Distribution** section.
- 4 From the **Distribution type** list, choose **Predefined**.
- 5 In the **Element ratio** text field, type 3.
- 6 Select the **Reverse direction** checkbox.


#### *Distribution 4*

- 1 Right-click **Mapped 1** and choose **Distribution**.
- 2 Select Edges 72 and 141 only.
- 3 In the **Settings** window for **Distribution**, locate the **Distribution** section.
- 4 In the **Number of elements** text field, type 3.


#### *Size*

In general, 5 to 6 second-order elements per wavelength are needed to resolve the waves. For more details, see *Meshing (Resolving the Waves)* in the *Acoustics Module User's Guide*. In this model, use 6 elements per wavelength.

- 1 In the **Model Builder** window, under **Component 1 (comp1) > Mesh 1** click **Size**.
- 2 In the **Settings** window for **Size**, locate the **Element Size** section.

- 3 Click the **Custom** button.
- 4 Locate the **Element Size Parameters** section. In the **Maximum element size** text field, type  $\lambda_{min}/6$ .
- 5 In the **Minimum element size** text field, type  $d_{visc}/2$ .
- 6 In the **Maximum element growth rate** text field, type 1.3.
- 7 Click  **Build All**.

#### *Free Triangular I*

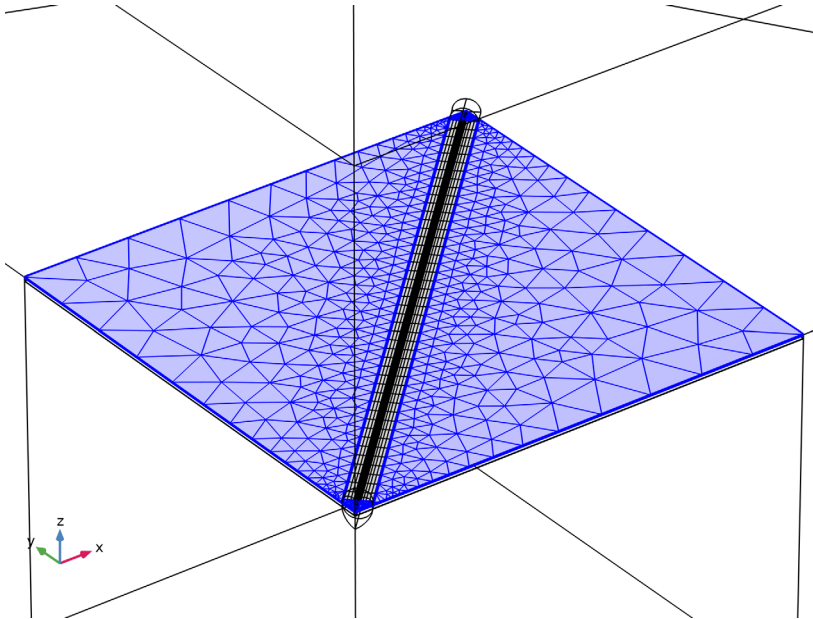
- 1 In the **Mesh** toolbar, click  **More Generators** and choose **Free Triangular**.
- 2 Select Boundaries 16, 35, 43, 63, 97, 108, 130, and 140 only.

#### *Size I*


- 1 Right-click **Free Triangular I** and choose **Size**.
- 2 In the **Settings** window for **Size**, locate the **Element Size** section.
- 3 Click the **Custom** button.
- 4 Locate the **Element Size Parameters** section.
- 5 Select the **Maximum element size** checkbox. In the associated text field, type  $d_{visc}*15$ .
- 6 Select the **Maximum element growth rate** checkbox. In the associated text field, type 1.2.

7 Click  **Build Selected**.

The mesh should look like this.



#### *Swept 1*

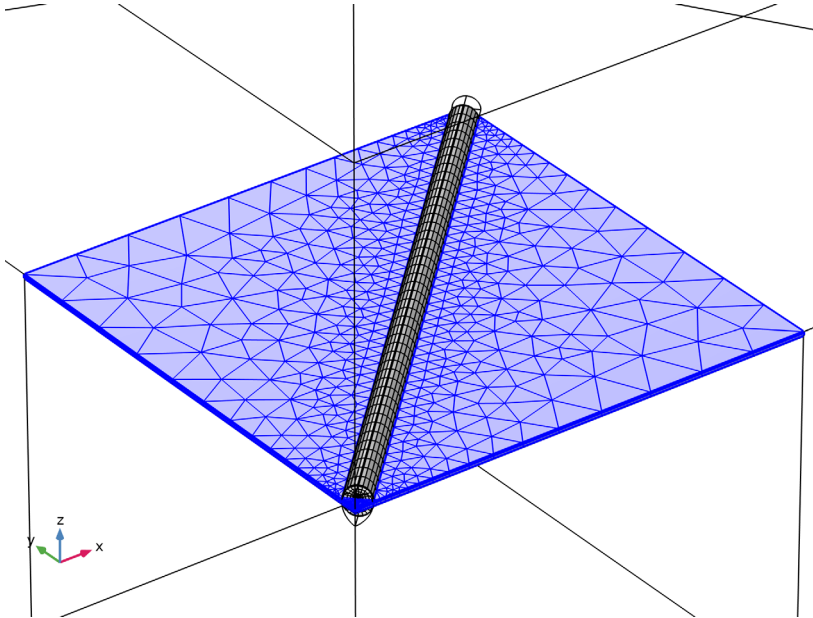
- 1 In the **Mesh** toolbar, click  **Swept**.
- 2 In the **Settings** window for **Swept**, locate the **Domain Selection** section.
- 3 From the **Geometric entity level** list, choose **Domain**.
- 4 Select Domains 3, 4, 8–13, 16, 17, 19–28, 30, and 32–37 only.

#### *Distribution 1*



- 1 Right-click **Swept 1** and choose **Distribution**.
- 2 Select Domains 4, 10, 11, 13, 17, 20, 23, 25, 27, 30, 33, 35, and 37 only.
- 3 In the **Settings** window for **Distribution**, locate the **Distribution** section.
- 4 In the **Number of elements** text field, type 2.

5 Click  **Build Selected**.


The mesh will be swept through the thermoviscous acoustics domains. This will reduce the computational cost of the analysis. The mesh should look like this.




#### *Free Tetrahedral 1*

- 1 In the **Mesh** toolbar, click  **Free Tetrahedral**.
- 2 In the **Settings** window for **Free Tetrahedral**, locate the **Domain Selection** section.
- 3 From the **Geometric entity level** list, choose **Domain**.
- 4 Select Domains 1, 2, 5, 6, 29, and 31 only.
- 5 Click  **Build Selected**.


#### *Swept 2*

In the **Mesh** toolbar, click  **Swept**.

#### *Distribution 1*

- 1 Right-click **Swept 2** and choose **Distribution**.
- 2 In the **Settings** window for **Distribution**, locate the **Distribution** section.
- 3 In the **Number of elements** text field, type 8.
- 4 Click  **Build Selected**.

### *Boundary Layers 1*


1 In the **Mesh** toolbar, click  **Boundary Layers**.

Add a boundary layer of a single element on the exterior field calculation boundary. This will guarantee that the gradients are computed correctly.

- 2 In the **Settings** window for **Boundary Layers**, locate the **Geometric Entity Selection** section.
- 3 From the **Geometric entity level** list, choose **Domain**.
- 4 Select Domain 6 only.
- 5 Click to expand the **Transition** section. Clear the **Smooth transition to interior mesh** checkbox.

### *Boundary Layer Properties*

1 In the **Model Builder** window, click **Boundary Layer Properties**.

- 2 In the **Settings** window for **Boundary Layer Properties**, locate the **Boundary Selection** section.
- 3 From the **Selection** list, choose **Exterior Field Boundaries**.
- 4 Locate the **Layers** section. In the **Number of layers** text field, type 1.
- 5 Click  **Build Selected**.


## **STUDY 1**

### *Step 2: Frequency-Domain Perturbation*

- 1 In the **Model Builder** window, under **Study 1** click **Step 2: Frequency-Domain Perturbation**.
- 2 In the **Settings** window for **Frequency-Domain Perturbation**, locate the **Study Settings** section.
- 3 In the **Frequencies** text field, type 10 5000 6000 7000 8000 9000 9200 9400 9475 9550 9600 9650 9725 9800 10000 10200 11000 12000 20000.
- 4 Select the **Include geometric nonlinearity** checkbox.


It is important to set this option in order for the prestress to be included in the frequency domain perturbation study step.

### *Solution 1 (sol1)*

- 1 In the **Study** toolbar, click  **Show Default Solver**.
- 2 In the **Model Builder** window, expand the **Solution 1 (sol1)** node.
- 3 In the **Model Builder** window, expand the **Study 1 > Solver Configurations > Solution 1 (sol1) > Stationary Solver 2** node.

- 4 Right-click **Study 1** > **Solver Configurations** > **Solution 1 (sol1)** > **Stationary Solver 2** > **Suggested Iterative Solver (GMRES with Direct Precond.) (pzl\_tsbl\_asbl\_atbl)** and choose **Enable**.

The iterative solver is more efficient for large models like this one.

- 5 In the **Settings** window for **Iterative**, click  **Run**.

## RESULTS

### *Sound Pressure Level (acpr)*


In the **Model Builder** window, under **Results** right-click **Sound Pressure Level (acpr)** and choose **Delete**.

### *Acoustic Pressure (ta)*

- 1 In the **Model Builder** window, right-click **Acoustic Pressure (ta)** and choose **Delete**.

These plots are not needed for the analysis.


### *Electric Potential (es)*

- 1 In the **Model Builder** window, under **Results** click **Electric Potential (es)**.
- 2 In the **Settings** window for **3D Plot Group**, click to expand the **Selection** section.
- 3 From the **Geometric entity level** list, choose **Domain**.
- 4 From the **Selection** list, choose **Electrostatics Domains**.
- 5 Select the **Apply to dataset edges** checkbox.
- 6 Locate the **Color Legend** section. Select the **Show units** checkbox.
- 7 In the **Electric Potential (es)** toolbar, click  **Plot**.

### *Multislice 1*

- 1 In the **Model Builder** window, expand the **Electric Potential (es)** node, then click **Multislice 1**.
- 2 In the **Settings** window for **Multislice**, locate the **Multipane Data** section.
- 3 Find the **x-planes** subsection. From the **Entry method** list, choose **Number of planes**.
- 4 In the **Planes** text field, type 0.
- 5 Find the **y-planes** subsection. From the **Entry method** list, choose **Number of planes**.
- 6 In the **Planes** text field, type 5.
- 7 Find the **z-planes** subsection. From the **Entry method** list, choose **Number of planes**.
- 8 In the **Planes** text field, type 0.

### *Streamline Multislice 1*

- 1 In the **Model Builder** window, click **Streamline Multislice 1**.
- 2 In the **Settings** window for **Streamline Multislice**, locate the **Multiplane Data** section.
- 3 Find the **x-planes** subsection. From the **Entry method** list, choose **Number of planes**.
- 4 In the **Planes** text field, type 0.
- 5 Find the **y-planes** subsection. From the **Entry method** list, choose **Number of planes**.
- 6 In the **Planes** text field, type 5.
- 7 Find the **z-planes** subsection. From the **Entry method** list, choose **Number of planes**.
- 8 In the **Planes** text field, type 0.
- 9 In the **Electric Potential (es)** toolbar, click  **Plot**.

The image should look like that in [Figure 3](#).

### *Acoustic Pressure (ta+acpr)*

- 1 In the **Model Builder** window, under **Results** click **Acoustic Pressure (acpr)**.
- 2 In the **Settings** window for **3D Plot Group**, type Acoustic Pressure (ta+acpr) in the **Label** text field.
- 3 Locate the **Selection** section. From the **Geometric entity level** list, choose **Domain**.
- 4 From the **Selection** list, choose **All except PML**.
- 5 Select the **Apply to dataset edges** checkbox.

### *Surface 1*


- 1 In the **Model Builder** window, expand the **Acoustic Pressure (ta+acpr)** node.
- 2 Right-click **Surface 1** and choose **Delete**.

### *Volume 1*

- 1 Right-click **Acoustic Pressure (ta+acpr)** and choose **Volume**.
- 2 In the **Settings** window for **Volume**, click **Replace Expression** in the upper-right corner of the **Expression** section. From the menu, choose **Component 1 (comp1) > Multiphysics > atb1.p\_t - Total acoustic pressure - Pa**.
- 3 Locate the **Expression** section.
- 4 Select the **Description** checkbox. In the associated text field, type Acoustic pressure.
- 5 Locate the **Coloring and Style** section. From the **Color table** list, choose **Wave**.
- 6 From the **Scale** list, choose **Linear symmetric**.

### *Filter 1*

- 1 Right-click **Volume 1** and choose **Filter**.

- 2 In the **Settings** window for **Filter**, locate the **Element Selection** section.
- 3 In the **Logical expression for inclusion** text field, type (x<y).
- 4 In the **Acoustic Pressure (ta+acpr)** toolbar, click  **Plot**.


The image should look like that in [Figure 4](#).

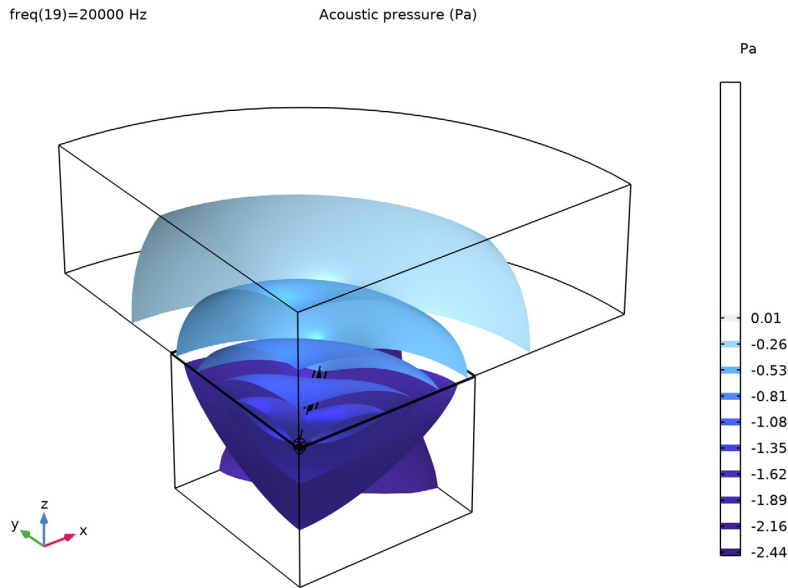
#### *Acoustic Pressure, Isosurfaces (ta+acpr)*

- 1 In the **Model Builder** window, under **Results** click **Acoustic Pressure, Isosurfaces (acpr)**.
- 2 In the **Settings** window for **3D Plot Group**, type Acoustic Pressure, Isosurfaces (ta+acpr) in the **Label** text field.
- 3 Locate the **Selection** section. From the **Geometric entity level** list, choose **Domain**.
- 4 From the **Selection** list, choose **All except PML**.
- 5 Select the **Apply to dataset edges** checkbox.


#### *Isosurface 1*

- 1 In the **Model Builder** window, expand the **Acoustic Pressure, Isosurfaces (ta+acpr)** node, then click **Isosurface 1**.
- 2 In the **Settings** window for **Isosurface**, click **Replace Expression** in the upper-right corner of the **Expression** section. From the menu, choose **Component 1 (comp1) > Multiphysics > atb1.p\_t - Total acoustic pressure - Pa**.
- 3 Locate the **Expression** section.
- 4 Select the **Description** checkbox. In the associated text field, type Acoustic pressure.

- 5 In the **Acoustic Pressure, Isosurfaces (ta+acpr)** toolbar, click  **Plot**.  
The image should look like this.




#### *Acoustic Velocity (ta)*

- 1 In the **Model Builder** window, under **Results** click **Acoustic Velocity (ta)**.
- 2 In the **Settings** window for **3D Plot Group**, locate the **Data** section.
- 3 From the **Parameter value (freq (Hz))** list, choose **9600**.
- 4 Locate the **Selection** section. From the **Geometric entity level** list, choose **Domain**.
- 5 From the **Selection** list, choose **Thermoviscous Domains**.
- 6 Select the **Apply to dataset edges** checkbox.
- 7 Locate the **Plot Settings** section. Clear the **Plot dataset edges** checkbox.
- 8 In the **Acoustic Velocity (ta)** toolbar, click  **Plot**.


#### *Slice*

- 1 In the **Model Builder** window, expand the **Acoustic Velocity (ta)** node, then click **Slice**.
- 2 In the **Settings** window for **Slice**, locate the **Plane Data** section.
- 3 From the **Plane type** list, choose **General**.
- 4 From the **Plane entry method** list, choose **Point and normal vector**.

- 5 Find the **Point** subsection. In the **x** text field, type 20.
- 6 In the **y** text field, type 20.
- 7 Find the **Normal vector** subsection. In the **x** text field, type 1.
- 8 In the **y** text field, type 1.
- 9 In the **z** text field, type 0.
- 10 Select the **Additional parallel planes** checkbox.
- 11 In the **Planes** text field, type 10.
- 12 In the **Acoustic Velocity (ta)** toolbar, click  **Plot**.

The image should look like that in [Figure 5](#).

#### *Temperature Variation (ta)*

- 1 In the **Model Builder** window, under **Results** click **Temperature Variation (ta)**.
- 2 In the **Settings** window for **3D Plot Group**, locate the **Data** section.
- 3 From the **Parameter value (freq (Hz))** list, choose **9600**.
- 4 Locate the **Selection** section. From the **Geometric entity level** list, choose **Domain**.
- 5 From the **Selection** list, choose **Thermoviscous Domains**.
- 6 Select the **Apply to dataset edges** checkbox.
- 7 Locate the **Plot Settings** section. Clear the **Plot dataset edges** checkbox.
- 8 In the **Temperature Variation (ta)** toolbar, click  **Plot**.

#### *Multislice*

- 1 In the **Model Builder** window, expand the **Temperature Variation (ta)** node.
- 2 Right-click **Multislice** and choose **Delete**.

#### *Slice 1*

- 1 Right-click **Temperature Variation (ta)** and choose **Slice**.
- 2 In the **Settings** window for **Slice**, locate the **Expression** section.
- 3 In the **Expression** text field, type  $ta.T_t$ .
- 4 Locate the **Plane Data** section. From the **Plane type** list, choose **General**.
- 5 From the **Plane entry method** list, choose **Point and normal vector**.
- 6 Find the **Point** subsection. In the **x** text field, type 20.
- 7 In the **y** text field, type 20.
- 8 Find the **Normal vector** subsection. In the **x** text field, type 1.
- 9 In the **y** text field, type 1.

10 In the **z** text field, type 0.

11 Select the **Additional parallel planes** checkbox.

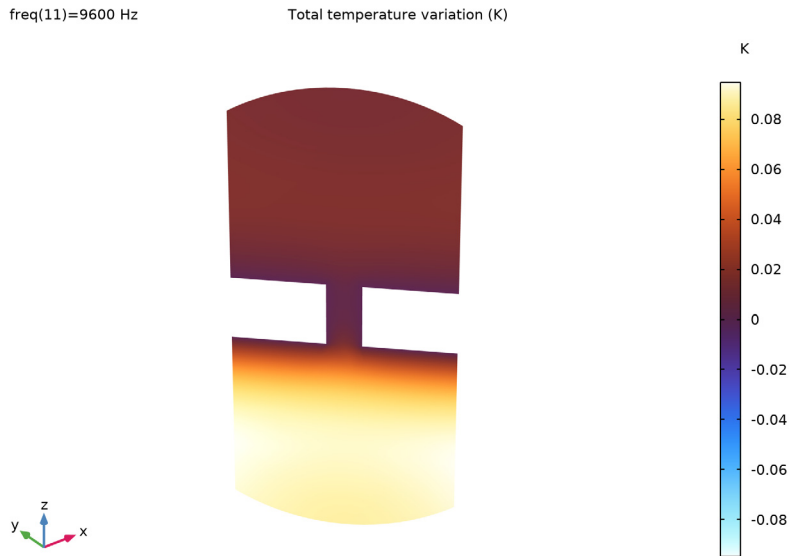
12 In the **Planes** text field, type 10.

13 Locate the **Coloring and Style** section. From the **Color table** list, choose **ThermalWave**.

14 From the **Scale** list, choose **Linear symmetric**.

15 In the **Temperature Variation (ta)** toolbar, click  **Plot**.

The image should look like this.



### *Logarithmic Thermoviscous Losses (ta)*

1 Right-click **Temperature Variation (ta)** and choose **Duplicate**.

2 In the **Settings** window for **3D Plot Group**, type *Logarithmic Thermoviscous Losses (ta)* in the **Label** text field.

### *Slice 1*


1 In the **Model Builder** window, expand the **Logarithmic Thermoviscous Losses (ta)** node, then click **Slice 1**.

2 In the **Settings** window for **Slice**, locate the **Expression** section.

3 In the **Expression** text field, type  $\log_{10}(ta.diss\_tot)$ .

- 4 Select the **Description** checkbox. In the associated text field, type  $\log_{10}(\text{Thermoviscous losses})$ .
  - 5 Click to expand the **Range** section. Select the **Manual color range** checkbox.
  - 6 In the **Minimum** text field, type 6.1.
  - 7 In the **Maximum** text field, type 8.1.
  - 8 Locate the **Coloring and Style** section. From the **Color table** list, choose **HeatCameraLight**.
  - 9 From the **Scale** list, choose **Linear**.
- The image should look like that in [Figure 6](#).

#### *Terminal Impedance*

- 1 In the **Results** toolbar, click  **ID Plot Group**.
- 2 In the **Settings** window for **ID Plot Group**, type Terminal Impedance in the **Label** text field.
- 3 Click to expand the **Title** section. From the **Title type** list, choose **Label**.
- 4 Locate the **Plot Settings** section. Select the **Two y-axes** checkbox.
- 5 Locate the **Axis** section. Select the **Manual axis limits** checkbox.
- 6 In the **x minimum** text field, type 18.
- 7 In the **x maximum** text field, type 20000.
- 8 In the **y minimum** text field, type 0.1.
- 9 In the **y maximum** text field, type 150.
- 10 In the **Secondary y minimum** text field, type -91.
- 11 In the **Secondary y maximum** text field, type -20.
- 12 Select the **x-axis log scale** checkbox.
- 13 Select the **y-axis log scale** checkbox.
- 14 Locate the **Legend** section. From the **Position** list, choose **Lower left**.

#### *Global I*

- 1 Right-click **Terminal Impedance** and choose **Global**.
- 2 In the **Settings** window for **Global**, locate the **y-Axis Data** section.
- 3 In the table, enter the following settings:

Expression	Unit	Description
$\text{abs}(1/\text{es.Y11})/4$	$\text{k}\Omega$	Magnitude

- 4 In the **Terminal Impedance** toolbar, click  **Plot**.

### Global 2

- 1 In the **Model Builder** window, right-click **Terminal Impedance** and choose **Global**.
- 2 In the **Settings** window for **Global**, locate the **y-Axis** section.
- 3 Select the **Plot on secondary y-axis** checkbox.
- 4 Locate the **y-Axis Data** section. In the table, enter the following settings:

Expression	Unit	Description
$\arg(1/es.Y11)$	deg	Phase


- 5 In the **Terminal Impedance** toolbar, click  **Plot**.

The image should look like that in [Figure 7](#).


### Study 1/Solution 1 (3) (sol1)

- In the **Results** toolbar, click  **More Datasets** and choose **Solution**.




### Selection


- 1 In the **Results** toolbar, click  **Attributes** and choose **Selection**.
- 2 In the **Settings** window for **Selection**, locate the **Geometric Entity Selection** section.
- 3 From the **Geometric entity level** list, choose **Domain**.
- 4 From the **Selection** list, choose **Electrostatics Domains**.

### Sector 3D 1

- 1 In the **Results** toolbar, click  **More Datasets** and choose **Sector 3D**.
- 2 In the **Settings** window for **Sector 3D**, locate the **Data** section.
- 3 From the **Dataset** list, choose **Study 1/Solution 1 (3) (sol1)**.
- 4 Locate the **Symmetry** section. In the **Number of sectors** text field, type 4.
- 5 From the **Transformation** list, choose **Rotation and reflection**.

### Model Thumbnail

- 1 In the **Results** toolbar, click  **3D Plot Group**.
- 2 In the **Settings** window for **3D Plot Group**, type Model Thumbnail in the **Label** text field.
- 3 Locate the **Data** section. From the **Dataset** list, choose **Sector 3D 1**.
- 4 From the **Parameter value (freq (Hz))** list, choose **9600**.
- 5 Locate the **Plot Settings** section. Clear the **Plot dataset edges** checkbox.
- 6 Locate the **Color Legend** section. Select the **Show units** checkbox.
- 7 In the **Model Thumbnail** toolbar, click  **Plot**.
- 8 Click the  **Show Grid** button in the **Graphics** toolbar.

9 Click the  **Zoom Extents** button in the **Graphics** toolbar.

#### *Volume 1*

Right-click **Model Thumbnail** and choose **Volume**.

#### *Deformation 1*

1 In the **Model Builder** window, right-click **Volume 1** and choose **Deformation**.

2 In the **Settings** window for **Deformation**, locate the **Scale** section.

3 Select the **Scale factor** checkbox. In the associated text field, type 100.

4 In the **Model Thumbnail** toolbar, click  **Plot**.

#### *Slice 1*

1 In the **Model Builder** window, right-click **Model Thumbnail** and choose **Slice**.

2 In the **Settings** window for **Slice**, locate the **Expression** section.

3 In the **Expression** text field, type `ta.v_inst`.

4 Locate the **Plane Data** section. From the **Plane type** list, choose **General**.

5 From the **Plane entry method** list, choose **Point and normal vector**.

6 Find the **Normal vector** subsection. In the **x** text field, type 1.

7 In the **y** text field, type 1.

8 In the **z** text field, type 0.

9 Select the **Additional parallel planes** checkbox.

10 In the **Planes** text field, type 20.

11 Locate the **Coloring and Style** section. Clear the **Color legend** checkbox.

12 From the **Color table** list, choose **Traffic**.

13 Click to expand the **Inherit Style** section. From the **Plot** list, choose **Volume 1**.

14 Clear the **Color** checkbox.

15 Clear the **Color and data range** checkbox.

16 In the **Model Thumbnail** toolbar, click  **Plot**.

#### *Deformation 1*

1 Right-click **Slice 1** and choose **Deformation**.



2 In the **Settings** window for **Deformation**, locate the **Expression** section.

3 In the **x-component** text field, type 0.

4 In the **y-component** text field, type 0.

5 In the **z-component** text field, type `linext1(w)`.

### *Slice 2*

- 1 In the **Model Builder** window, under **Results > Model Thumbnail** right-click **Slice 1** and choose **Duplicate**.
- 2 In the **Settings** window for **Slice**, locate the **Plane Data** section.
- 3 Find the **Normal vector** subsection. In the **x** text field, type -1.
- 4 Click to expand the **Title** section. From the **Title type** list, choose **None**.
- 5 In the **Model Thumbnail** toolbar, click  **Plot**.
- 6 Click the  **Go to Default View** button in the **Graphics** toolbar.


### *Line 1*

- 1 In the **Model Builder** window, right-click **Model Thumbnail** and choose **Line**.
- 2 In the **Settings** window for **Line**, locate the **Expression** section.
- 3 In the **Expression** text field, type 0.
- 4 Click to expand the **Title** section. From the **Title type** list, choose **None**.
- 5 Locate the **Coloring and Style** section. From the **Coloring** list, choose **Uniform**.
- 6 From the **Color** list, choose **Black**.
- 7 Click to expand the **Inherit Style** section. From the **Plot** list, choose **Volume 1**.
- 8 Clear the **Color** checkbox.
- 9 Clear the **Color and data range** checkbox.

### *Deformation 1*

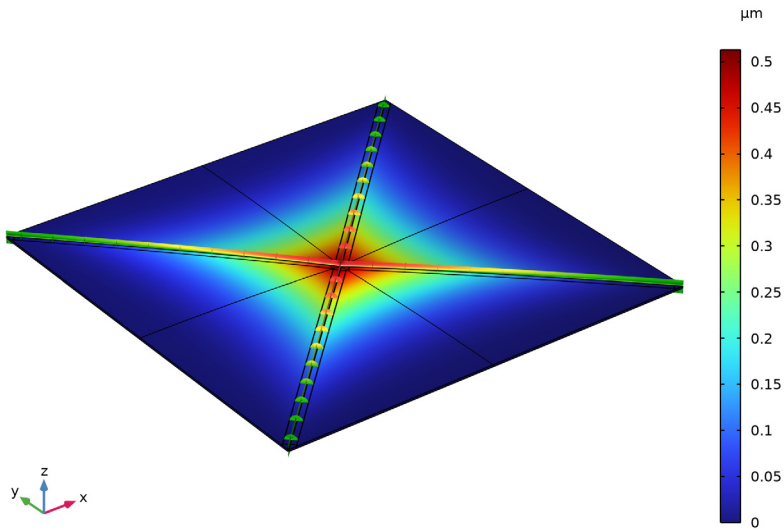
Right-click **Line 1** and choose **Deformation**.

### *Model Thumbnail*


- 1 In the **Model Thumbnail** toolbar, click  **Plot**.  
The image should look like this.

2 In the **Model Builder** window, under **Results** click **Model Thumbnail**.

freq(11)=9600 Hz Volume: Displacement magnitude ( $\mu\text{m}$ ) Slice: Instantaneous total acoustic velocity (m/s)




*Stationary Deformation (prestress)*

- 1 In the **Results** toolbar, click  **3D Plot Group**.
- 2 In the **Settings** window for **3D Plot Group**, type **Stationary Deformation (prestress)** in the **Label** text field.
- 3 Locate the **Data** section. From the **Dataset** list, choose **Study 1/Solution Store 1 (sol2)**.
- 4 Click to expand the **Title** section. From the **Title type** list, choose **Label**.
- 5 Locate the **Color Legend** section. Select the **Show units** checkbox.

*Surface 1*

- 1 Right-click **Stationary Deformation (prestress)** and choose **Surface**.
- 2 In the **Settings** window for **Surface**, locate the **Expression** section.
- 3 In the **Expression** text field, type `abs(w)`.

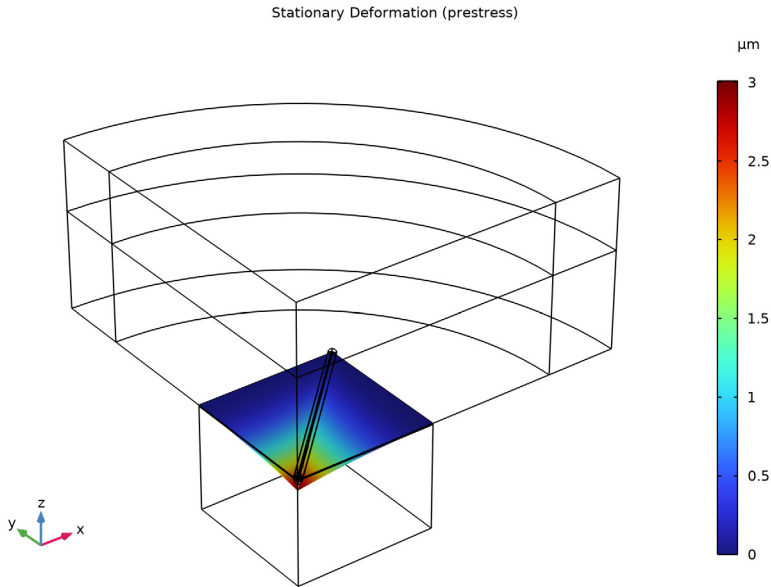
*Deformation 1*

- 1 Right-click **Surface 1** and choose **Deformation**.
- 2 In the **Stationary Deformation (prestress)** toolbar, click  **Plot**.


The stationary deformation should look like this. Note that the stationary deformation is only  $3[\mu\text{m}]$  at the center (the displacement scale is exaggerated in the plot). The

deformation is small compared to the total membrane thickness of 17[ $\mu\text{m}$ ]. This indicates that the effects of topology changes, that could be captured by the introduction of a **Moving Mesh** feature, can be disregarded.


- 3 In the **Model Builder** window, click **Deformation 1**.



#### *On-Axis Response at 10 cm*

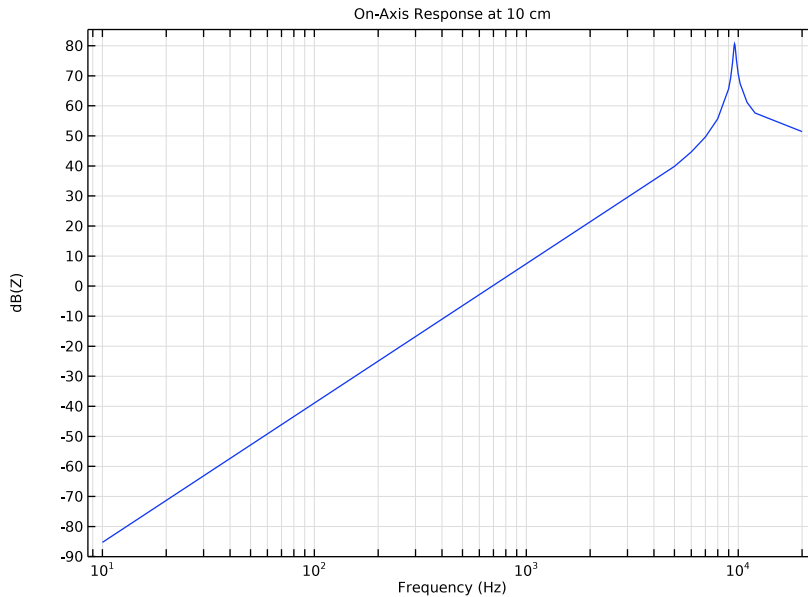
- 1 In the **Results** toolbar, click  **ID Plot Group**.
- 2 In the **Settings** window for **ID Plot Group**, type On-Axis Response at 10 cm in the **Label** text field.
- 3 Locate the **Title** section. From the **Title type** list, choose **Label**.

#### *Octave Band 1*



- 1 In the **On-Axis Response at 10 cm** toolbar, click  **More Plots** and choose **Octave Band**.
- 2 In the **Settings** window for **Octave Band**, locate the **Selection** section.
- 3 From the **Geometric entity level** list, choose **Global**.
- 4 Locate the **y-Axis Data** section. In the **Expression** text field, type  $\text{pext}(0, 0, 10[\text{cm}])$ .
- 5 Locate the **Plot** section. From the **Quantity** list, choose **Continuous power spectral density**.

6 In the **On-Axis Response at 10 cm** toolbar, click  **Plot**.

The on-axis response, 10 cm above the speaker, should look like this.



## RESULT TEMPLATES

- 1 In the **Results** toolbar, click  **Result Templates** to open the **Result Templates** window.
- 2 Go to the **Result Templates** window.
- 3 In the tree, select **Study 1/Solution 1 (1) (sol1) > Solid Mechanics > Displacement (solid)**.
- 4 Click the **Add Result Template** button in the window toolbar.
- 5 In the **Results** toolbar, click  **Result Templates** to close the **Result Templates** window.

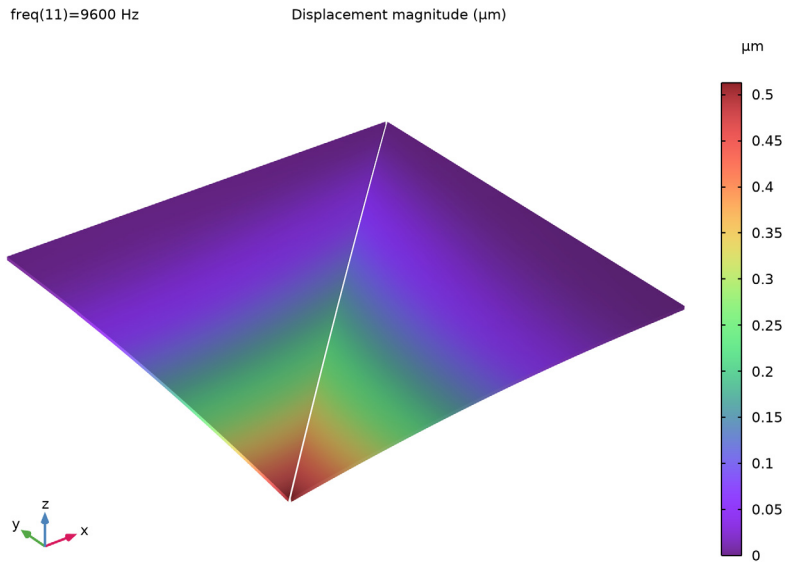
## RESULTS

### *Displacement (solid)*

- 1 In the **Settings** window for **3D Plot Group**, locate the **Data** section.
- 2 From the **Parameter value (freq (Hz))** list, choose **9600**.
- 3 Locate the **Plot Settings** section. Clear the **Plot dataset edges** checkbox.
- 4 Locate the **Color Legend** section. Select the **Show units** checkbox.

5 In the **Displacement (solid)** toolbar, click  **Plot**.

The image should look like that in [Figure 2](#).




### *Appendix: Geometry Sequence Instructions*


---

From the **File** menu, choose **New**.

#### **NEW**

In the **New** window, click  **Model Wizard**.

#### **MODEL WIZARD**

1 In the **Model Wizard** window, click  **3D**.

2 Click  **Done**.

#### **GEOMETRY I**

Adjust the units of the model to  $\mu\text{m}$ .

1 In the **Model Builder** window, under **Component 1 (comp1)** click **Geometry 1**.

2 In the **Settings** window for **Geometry**, locate the **Units** section.

3 From the **Length unit** list, choose **µm**.

Import the parameters from an external file. This file contains parameters like dimensions, maximum frequency and voltage that define the current model.

## GLOBAL DEFINITIONS

### Parameters 1

1 In the **Model Builder** window, under **Global Definitions** click **Parameters 1**.


2 In the **Settings** window for **Parameters**, locate the **Parameters** section.

3 In the table, enter the following settings:


Name	Expression	Value	Description
l_speaker	4[mm]	0.004 m	Side of the speaker
th_si	15[um]	1.5E-5 m	Thickness of the silicon layer
th_pzt	2[um]	2E-6 m	Thickness of the PZT layer
air_gap	9[um]	9E-6 m	Air gap between the actuators
d_speaker	1.5[mm]	0.0015 m	Back cavity depth

Create a **Work Plane** where the main features of the speaker will be defined. The model uses symmetry to only model one fourth of the geometry. This reduces the computation time.

## GEOMETRY 1

Click the  **Show Grid** button in the **Graphics** toolbar.

### Work Plane 1 (wp1)

In the **Geometry** toolbar, click  **Work Plane**.

### Work Plane 1 (wp1) > Plane Geometry


In the **Model Builder** window, click **Plane Geometry**.


### Work Plane 1 (wp1) > Square 1 (sq1)

1 In the **Work Plane** toolbar, click  **Square**.


2 In the **Settings** window for **Square**, locate the **Size** section.

3 In the **Side length** text field, type  $l\_speaker/2$ .

4 Click  **Build Selected**.

5 Click the  **Zoom Extents** button in the **Graphics** toolbar.

Work Plane 1 (wp1) > Rectangle 1 (r1)

1 In the **Work Plane** toolbar, click  **Rectangle**.

Create a rectangle that represents the air gap in the membrane. This gap will be modeled using Thermoviscous Acoustics.

2 In the **Settings** window for **Rectangle**, locate the **Size and Shape** section.

3 In the **Width** text field, type  $\sqrt{2}/2*1\_speaker-air\_gap$ .

4 In the **Height** text field, type  $12*air\_gap$ .

5 Locate the **Position** section. From the **Base** list, choose **Center**.

6 In the **xw** text field, type  $1\_speaker/4$ .

7 In the **yw** text field, type  $1\_speaker/4$ .

8 Locate the **Rotation Angle** section. In the **Rotation** text field, type 45.

9 Click to expand the **Layers** section. In the table, enter the following settings:


Layer name	Thickness (µm)
Layer 1	$5.5*air\_gap$

10 Select the **Layers on top** checkbox.

11 Click  **Build Selected**.

Create a new rectangle so that a swept mesh can be generated in the Thermoviscous Acoustics domains.

Work Plane 1 (wp1) > Rectangle 2 (r2)

1 In the **Work Plane** toolbar, click  **Rectangle**.

2 In the **Settings** window for **Rectangle**, locate the **Size and Shape** section.

3 In the **Width** text field, type  $\sqrt{2}/2*1\_speaker-16*air\_gap$ .

4 In the **Height** text field, type  $12*air\_gap$ .

5 Locate the **Position** section. From the **Base** list, choose **Center**.

6 In the **xw** text field, type  $1\_speaker/4$ .

7 In the **yw** text field, type  $1\_speaker/4$ .

8 Locate the **Rotation Angle** section. In the **Rotation** text field, type 45.


Work Plane 1 (wp1) > Union 1 (uni1)

1 In the **Work Plane** toolbar, click  **Booleans and Partitions** and choose **Union**.

2 Click in the **Graphics** window and then press Ctrl+A to select all objects.

3 In the **Settings** window for **Union**, click  **Build Selected**.

*Work Plane 1 (wp1) > Delete Entities 1 (del1)*

- 1 Right-click **Plane Geometry** and choose **Delete Entities**.
- 2 In the **Settings** window for **Delete Entities**, locate the **Entities or Objects to Delete** section.
- 3 From the **Geometric entity level** list, choose **Domain**.
- 4 On the object **uni1**, select Domains 1, 6, 13, and 17 only.
- 5 Click  **Build Selected**.

Extrude the **Work Plane 1** to create the 3D geometry that represents the silicon and the PZT Layers of the membrane.

*Extrude 1 (ext1)*

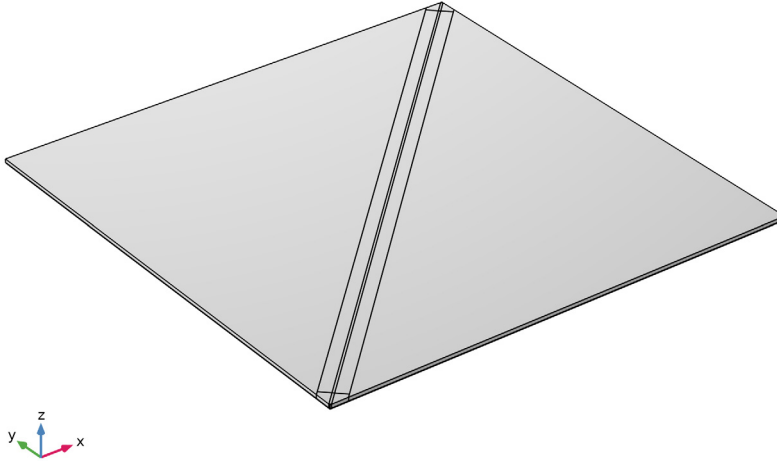
- 1 In the **Model Builder** window, under **Component 1 (comp1) > Geometry 1** right-click **Work Plane 1 (wp1)** and choose **Extrude**.
- 2 In the **Settings** window for **Extrude**, locate the **Distances** section.
- 3 In the table, enter the following settings:

<b>Distances (µm)</b>
th_si
th_si+th_pzt

- 4 Select the **Reverse direction** checkbox.


5 Click  **Build Selected**.

The geometry should look like this.



Add a cylinder that will be used for the Thermoviscous Acoustics domains.

*Cylinder 1 (cyl1)*

- 1 In the **Geometry** toolbar, click  **Cylinder**.
- 2 In the **Settings** window for **Cylinder**, locate the **Size and Shape** section.
- 3 In the **Radius** text field, type  $6 \cdot \text{air\_gap}$ .
- 4 In the **Height** text field, type  $\sqrt{2} / 2 \cdot l_{\text{speaker}}$ .
- 5 Locate the **Axis** section. From the **Axis type** list, choose **Cartesian**.
- 6 In the **x** text field, type 1.
- 7 In the **y** text field, type 1.
- 8 In the **z** text field, type 0.
- 9 Click to expand the **Layers** section. In the table, enter the following settings:

Layer name	Thickness ( $\mu\text{m}$ )
Layer 1	$8 \cdot \text{air\_gap}$

- 10 Clear the **Layers on side** checkbox.

11 Select the **Layers on bottom** checkbox.

12 Select the **Layers on top** checkbox.

13 Click  **Build Selected**.

Split the cylinder in two halves and move them to the right location in the following steps.

#### *Partition Objects 1 (par1)*

1 In the **Geometry** toolbar, click  **Booleans and Partitions** and choose **Partition Objects**.

2 Select the object **cyl1** only.

3 In the **Settings** window for **Partition Objects**, locate the **Partition Objects** section.

4 From the **Partition with** list, choose **Work plane**.

5 Click  **Build Selected**.

#### *Move 1 (mov1)*

1 In the **Geometry** toolbar, click  **Transforms** and choose **Move**.

2 Select the object **par1** only.

3 In the **Settings** window for **Move**, locate the **Displacement** section.

4 In the **z** text field, type `-th_pzt - th_si`.

5 Locate the **Input** section. Select the **Keep input objects** checkbox.

6 Click  **Build Selected**.

#### *Delete Entities 1 (del1)*


1 In the **Model Builder** window, right-click **Geometry 1** and choose **Delete Entities**.

2 In the **Settings** window for **Delete Entities**, locate the **Entities or Objects to Delete** section.

3 From the **Geometric entity level** list, choose **Domain**.


4 On the object **mov1**, select Domains 2, 4, and 6 only.

5 On the object **par1**, select Domains 1, 3, and 5 only.

6 Click  **Build Selected**.

Add a cylinder that represents an infinite domain in front of the speaker.

#### *Cylinder 2 (cyl2)*



1 In the **Geometry** toolbar, click  **Cylinder**.

2 In the **Settings** window for **Cylinder**, locate the **Size and Shape** section.

3 In the **Radius** text field, type `1.2*1_speaker`.



- 4 In the **Height** text field, type  $1.2 * l_{\text{speaker}}$ .
- 5 Locate the **Position** section. In the **z** text field, type  $-0.6 * l_{\text{speaker}}$ .
- 6 Locate the **Layers** section. In the table, enter the following settings:

Layer name	Thickness ( $\mu\text{m}$ )
Layer 1	$l_{\text{speaker}}/4$


- 7 Select the **Layers on bottom** checkbox.
- 8 Select the **Layers on top** checkbox.
- 9 Click  **Build Selected**.
- 10 Click the  **Wireframe Rendering** button in the **Graphics** toolbar.

**Wireframe Rendering** simplifies the selection of boundaries in the geometry.


#### *Partition Objects 2 (par2)*

- 1 In the **Geometry** toolbar, click  **Booleans and Partitions** and choose **Partition Objects**.
- 2 Select the object **cyl2** only.
- 3 In the **Settings** window for **Partition Objects**, locate the **Partition Objects** section.
- 4 From the **Partition with** list, choose **Work plane**.
- 5 Click  **Build Selected**.

#### *Delete Entities 2 (del2)*

- 1 Right-click **Geometry 1** and choose **Delete Entities**.
- 2 In the **Settings** window for **Delete Entities**, locate the **Entities or Objects to Delete** section.
- 3 From the **Geometric entity level** list, choose **Domain**.
- 4 On the object **par2**, select Domains 1–4, 9, 10, 13, 14, 17, and 18 only.
- 5 Click  **Build Selected**.

#### *Block 1 (blk1)*

- 1 In the **Geometry** toolbar, click  **Block**.  
This block represents the back volume of the speaker.
- 2 In the **Settings** window for **Block**, locate the **Size and Shape** section.
- 3 In the **Width** text field, type  $l_{\text{speaker}}/2$ .
- 4 In the **Depth** text field, type  $l_{\text{speaker}}/2$ .
- 5 In the **Height** text field, type  $d_{\text{speaker}}$ .
- 6 Locate the **Position** section. In the **z** text field, type  $-th_{\text{si}} - th_{\text{pzt}} - d_{\text{speaker}}$ .

7 Click  **Build Selected**.

#### *Work Plane 2 (wp2)*

1 In the **Geometry** toolbar, click  **Work Plane**.

This is the first symmetry plane.

2 In the **Settings** window for **Work Plane**, locate the **Plane Definition** section.

3 From the **Plane** list, choose **yz-plane**.

#### *Work Plane 3 (wp3)*

1 In the **Geometry** toolbar, click  **Work Plane**.

This is the second symmetry plane.

2 In the **Settings** window for **Work Plane**, locate the **Plane Definition** section.

3 From the **Plane** list, choose **zx-plane**.

#### *Union 1 (uni1)*

1 In the **Geometry** toolbar, click  **Booleans and Partitions** and choose **Union**.

2 Select the object **del2** only.

3 Click in the **Graphics** window and then press Ctrl+A to select all objects.

4 In the **Settings** window for **Union**, click  **Build Selected**.

#### *Partition Objects 3 (par3)*

1 In the **Geometry** toolbar, click  **Booleans and Partitions** and choose **Partition Objects**.

2 Select the object **uni1** only.

3 In the **Settings** window for **Partition Objects**, locate the **Partition Objects** section.

4 From the **Partition with** list, choose **Work plane**.

5 From the **Work plane** list, choose **Work Plane 2 (wp2)**.

6 Click  **Build Selected**.

#### *Partition Objects 4 (par4)*

1 In the **Geometry** toolbar, click  **Booleans and Partitions** and choose **Partition Objects**.

2 Select the object **par3** only.

3 In the **Settings** window for **Partition Objects**, locate the **Partition Objects** section.

4 From the **Partition with** list, choose **Work plane**.

5 Click  **Build Selected**.

### Delete Entities 3 (del3)

- 1 Right-click **Geometry 1** and choose **Delete Entities**.


Delete the domains outside of the first quadrant xy-plane.

- 2 In the **Settings** window for **Delete Entities**, locate the **Entities or Objects to Delete** section.

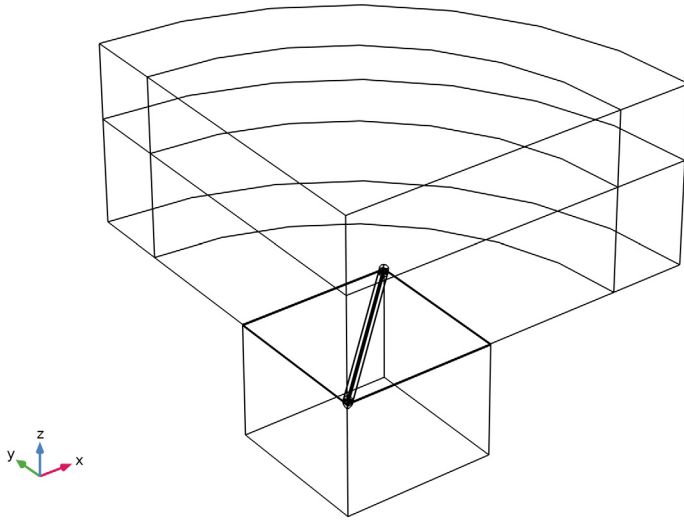
- 3 From the **Geometric entity level** list, choose **Domain**.

- 4 On the object **par4**, select Domains 1–14, 17, 21, 48, and 55 only.

- 5 Click  **Build Selected**.

- 6 Click the  **Zoom Extents** button in the **Graphics** toolbar.

The geometry should look like this.



### Thermoviscous Domain 1

- 1 In the **Geometry** toolbar, click  **Selections** and choose **Cylinder Selection**.


This selection includes the domains that will be represented using the **Thermoviscous Acoustics, Frequency Domain** interface.

- 2 In the **Settings** window for **Cylinder Selection**, type Thermoviscous Domain 1 in the **Label** text field.


- 3 Locate the **Size and Shape** section. In the **Outer radius** text field, type  $6 \cdot \text{air\_gap}$ .

- 4 Locate the **Axis** section. From the **Axis type** list, choose **Cartesian**.
- 5 In the **x** text field, type 1.
- 6 In the **y** text field, type 1.
- 7 In the **z** text field, type 0.
- 8 Locate the **Output Entities** section. From the **Include entity if** list, choose **All vertices inside cylinder**.


#### *Thermoviscous Domain 2*

- 1 Right-click **Thermoviscous Domain 1** and choose **Duplicate**.
- 2 In the **Settings** window for **Cylinder Selection**, type Thermoviscous Domain 2 in the **Label** text field.
- 3 Locate the **Position** section. In the **z** text field, type -th\_si-th\_pzt.
- 4 Click  **Build Selected**.

#### *Thermoviscous Domains*

- 1 In the **Geometry** toolbar, click  **Selections** and choose **Union Selection**.
- 2 In the **Settings** window for **Union Selection**, type Thermoviscous Domains in the **Label** text field.
- 3 Locate the **Input Entities** section. Click **+ Add**.
- 4 In the **Add** dialog, in the **Selections to add** list, choose **Thermoviscous Domain 1** and **Thermoviscous Domain 2**.
- 5 Click **OK**.
- 6 In the **Settings** window for **Union Selection**, locate the **Color** section.
- 7 From the **Color** list, choose **Color 5**.

#### *Silicon Layer With Air*



- 1 In the **Geometry** toolbar, click  **Selections** and choose **Box Selection**.
- 2 In the **Settings** window for **Box Selection**, type Silicon Layer With Air in the **Label** text field.
- 3 Locate the **Box Limits** section. In the **z minimum** text field, type -th\_si.
- 4 In the **z maximum** text field, type 0.
- 5 Locate the **Output Entities** section. From the **Include entity if** list, choose **Entity inside box**.

#### *PZT Layer With Air*


- 1 In the **Geometry** toolbar, click  **Selections** and choose **Box Selection**.

- 2 In the **Settings** window for **Box Selection**, type PZT Layer With Air in the **Label** text field.
- 3 Locate the **Box Limits** section. In the **z minimum** text field, type -th\_si-th\_pzt.
- 4 In the **z maximum** text field, type -th\_si.
- 5 Locate the **Output Entities** section. From the **Include entity if** list, choose **Entity inside box**.



#### *Silicon Domains*

- 1 In the **Geometry** toolbar, click  **Selections** and choose **Difference Selection**.
- 2 In the **Settings** window for **Difference Selection**, type Silicon Domains in the **Label** text field.
- 3 Locate the **Input Entities** section. Click the **+ Add** button for **Selections to add**.
- 4 In the **Add** dialog, select **Silicon Layer With Air** in the **Selections to add** list.
- 5 Click **OK**.
- 6 In the **Settings** window for **Difference Selection**, locate the **Input Entities** section.
- 7 Click the **+ Add** button for **Selections to subtract**.
- 8 In the **Add** dialog, select **Thermoviscous Domains** in the **Selections to subtract** list.
- 9 Click **OK**.
- 10 In the **Settings** window for **Difference Selection**, locate the **Color** section.
- 11 From the **Color** list, choose **Color 8**.
- 12 Click  **Build Selected**.



#### *PZT Domains*

- 1 In the **Geometry** toolbar, click  **Selections** and choose **Difference Selection**.
- 2 In the **Settings** window for **Difference Selection**, type PZT Domains in the **Label** text field.
- 3 Locate the **Input Entities** section. Click the **+ Add** button for **Selections to add**.
- 4 In the **Add** dialog, select **PZT Layer With Air** in the **Selections to add** list.
- 5 Click **OK**.
- 6 In the **Settings** window for **Difference Selection**, locate the **Input Entities** section.
- 7 Click the **+ Add** button for **Selections to subtract**.
- 8 In the **Add** dialog, select **Thermoviscous Domains** in the **Selections to subtract** list.
- 9 Click **OK**.
- 10 In the **Settings** window for **Difference Selection**, locate the **Color** section.
- 11 From the **Color** list, choose **Color 12**.



### *Structural Domains*

- 1 In the **Geometry** toolbar, click  **Selections** and choose **Union Selection**.
- 2 In the **Settings** window for **Union Selection**, type Structural1 Domains in the **Label** text field.
- 3 Locate the **Input Entities** section. Click  **Add**.
- 4 In the **Add** dialog, in the **Selections to add** list, choose **Silicon Domains** and **PZT Domains**.
- 5 Click **OK**.






### *All Domains*

- 1 In the **Geometry** toolbar, click  **Selections** and choose **Ball Selection**.
- 2 In the **Settings** window for **Ball Selection**, type All Domains in the **Label** text field.
- 3 Locate the **Ball Radius** section. In the **Radius** text field, type 2\*1\_speaker.
- 4 Click  **Build Selected**.



### *Inner Domains*

- 1 In the **Geometry** toolbar, click  **Selections** and choose **Cylinder Selection**.
- 2 In the **Settings** window for **Cylinder Selection**, type Inner Domains in the **Label** text field.
- 3 Locate the **Size and Shape** section. In the **Outer radius** text field, type 0.8\*1\_speaker.
- 4 In the **Top distance** text field, type 0.3\*1\_speaker.
- 5 Click  **Build Selected**.


### *PML Domains*

- 1 In the **Geometry** toolbar, click  **Selections** and choose **Difference Selection**.
- 2 In the **Settings** window for **Difference Selection**, type PML Domains in the **Label** text field.
- 3 Locate the **Input Entities** section. Click the  **Add** button for **Selections to add**.
- 4 In the **Add** dialog, select **All Domains** in the **Selections to add** list.
- 5 Click **OK**.
- 6 In the **Settings** window for **Difference Selection**, locate the **Input Entities** section.
- 7 Click the  **Add** button for **Selections to subtract**.
- 8 In the **Add** dialog, select **Inner Domains** in the **Selections to subtract** list.
- 9 Click **OK**.
- 10 In the **Settings** window for **Difference Selection**, click  **Build Selected**.
- 11 Click  **Build Selected**.


### *Pressure Acoustics Domains*

- 1 In the **Geometry** toolbar, click  **Selections** and choose **Difference Selection**.
- 2 In the **Settings** window for **Difference Selection**, type Pressure Acoustics Domains in the **Label** text field.
- 3 Locate the **Input Entities** section. Click the **+ Add** button for **Selections to add**.
- 4 In the **Add** dialog, select **All Domains** in the **Selections to add** list.
- 5 Click **OK**.
- 6 In the **Settings** window for **Difference Selection**, locate the **Input Entities** section.
- 7 Click the **+ Add** button for **Selections to subtract**.
- 8 In the **Add** dialog, in the **Selections to subtract** list, choose **Thermoviscous Domains** and **Structural Domains**.
- 9 Click **OK**.
- 10 In the **Settings** window for **Difference Selection**, locate the **Color** section.
- 11 From the **Color** list, choose **Color 10**.
- 12 Click  **Build Selected**.

### *Electrostatics Domains*

- 1 In the **Geometry** toolbar, click  **Selections** and choose **Union Selection**.
- 2 In the **Settings** window for **Union Selection**, type Electrostatics Domains in the **Label** text field.
- 3 Locate the **Input Entities** section. Click **+ Add**.
- 4 In the **Add** dialog, in the **Selections to add** list, choose **Thermoviscous Domains** and **Structural Domains**.
- 5 Click **OK**.

### *Air Domains*


- 1 In the **Geometry** toolbar, click  **Selections** and choose **Union Selection**.
- 2 In the **Settings** window for **Union Selection**, type Air Domains in the **Label** text field.
- 3 Locate the **Input Entities** section. Click **+ Add**.
- 4 In the **Add** dialog, in the **Selections to add** list, choose **Thermoviscous Domains** and **Pressure Acoustics Domains**.
- 5 Click **OK**.

### *All Boundaries*


- 1 In the **Geometry** toolbar, click  **Selections** and choose **Box Selection**.

- 2 In the **Settings** window for **Box Selection**, type All Boundaries in the **Label** text field.
- 3 Locate the **Geometric Entity Level** section. From the **Level** list, choose **Boundary**.


#### *Nonsymmetric Boundaries*

- 1 In the **Geometry** toolbar, click  **Selections** and choose **Box Selection**.
- 2 In the **Settings** window for **Box Selection**, type Nonsymmetric Boundaries in the **Label** text field.
- 3 Locate the **Geometric Entity Level** section. From the **Level** list, choose **Boundary**.
- 4 Locate the **Box Limits** section. In the **x minimum** text field, type 0.01.
- 5 In the **y minimum** text field, type 0.01.

#### *Symmetric Boundaries*

- 1 In the **Geometry** toolbar, click  **Selections** and choose **Difference Selection**.
- 2 In the **Settings** window for **Difference Selection**, type Symmetric Boundaries in the **Label** text field.
- 3 Locate the **Geometric Entity Level** section. From the **Level** list, choose **Boundary**.
- 4 Locate the **Input Entities** section. Click the **+ Add** button for **Selections to add**.
- 5 In the **Add** dialog, select **All Boundaries** in the **Selections to add** list.
- 6 Click **OK**.
- 7 In the **Settings** window for **Difference Selection**, locate the **Input Entities** section.
- 8 Click the **+ Add** button for **Selections to subtract**.
- 9 In the **Add** dialog, select **Nonsymmetric Boundaries** in the **Selections to subtract** list.
- 10 Click **OK**.

#### *Exterior Field Boundaries*


- 1 In the **Geometry** toolbar, click  **Selections** and choose **Explicit Selection**.
- 2 In the **Settings** window for **Explicit Selection**, type Exterior Field Boundaries in the **Label** text field.
- 3 Locate the **Entities to Select** section. From the **Geometric entity level** list, choose **Boundary**.
- 4 On the object **del3**, select Boundaries 23 and 49 only.

#### *Ground*



- 1 In the **Geometry** toolbar, click  **Selections** and choose **Explicit Selection**.
- 2 In the **Settings** window for **Explicit Selection**, type Ground in the **Label** text field.

- 3 Locate the **Entities to Select** section. From the **Geometric entity level** list, choose **Boundary**.
- 4 On the object **del3**, select Boundaries 33, 42, 62, 71, 89, 96, 107, and 129 only.

*Terminal*

- 1 In the **Geometry** toolbar, click  **Selections** and choose **Explicit Selection**.
- 2 In the **Settings** window for **Explicit Selection**, type Terminal in the **Label** text field.
- 3 Locate the **Entities to Select** section. From the **Geometric entity level** list, choose **Boundary**.
- 4 On the object **del3**, select Boundaries 28, 39, 59, 67, 86, 93, 102, and 126 only.

*All except PML*

- 1 In the **Geometry** toolbar, click  **Selections** and choose **Complement Selection**.
- 2 In the **Settings** window for **Complement Selection**, type All except PML in the **Label** text field.
- 3 Locate the **Input Entities** section. Click  **Add**.
- 4 In the **Add** dialog, select **PML Domains** in the **Selections to invert** list.
- 5 Click **OK**.