



Model created in COMSOL Multiphysics 6.4

# OW Microspeaker: Simulation and Correlation with Measurements

## *Introduction*

---

In this tutorial, the electromagnetic, mechanical, and acoustical characteristics of the Ole Wolff OWS-1943T-8CP (discontinued) microspeaker are analyzed and correlated to measurements performed by Ole Wolff Electronics. In this context, microspeakers are electrodynamic transducers of reduced dimensions that are used in small electronic equipment like smartphones, laptops, hand-held terminals, or scanners to reproduce most of the acoustic frequency range in a single transducer.

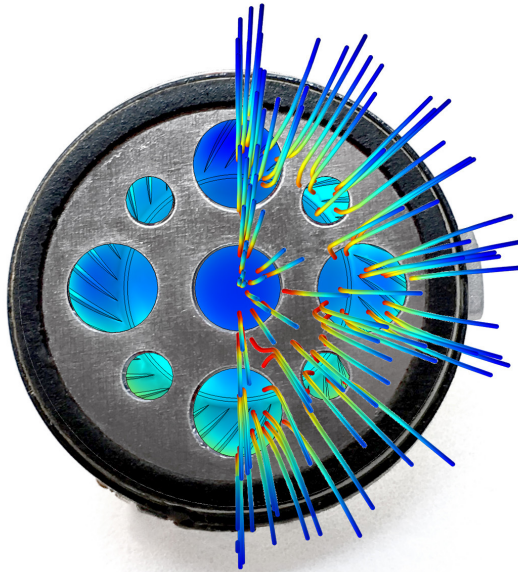

*Figure 1: The OWS-1943T-8CP microspeaker with model results superposed.*

In the first step, starting from the geometry of the speaker, an axisymmetric electromagnetic model is used to characterize the frequency-dependent response of the voice coil and the magnetic circuit. In the second step, the nonlinear mechanical characteristics of the diaphragm are computed and compared to measurements. In the third step, a lumped circuit, representing the electromagnetic physics, is coupled to a 3D model where the mechanical and acoustic response of the speaker is analyzed and compared with measurements. The comparison with measurements shows a good level of correlation for all of the physics and measurements considered.

---

**Note:** In this model, the OWS-1943T-8CP (discontinued) speaker geometry and measurement data are copyright by Ole Wolff Elektronik A/S.

---

### *Model Definition*

The geometry of the microspeaker is shown in [Figure 2](#). The requirement for compactness makes the general layout of the speaker differ from traditional dynamic loudspeakers; in this microspeaker the diaphragm covers the functions of diaphragm, dust cap, and spider used in larger loudspeakers. The dimensions of the speaker are approximately 19 mm in diameter and 2.8 mm in height.

The microspeaker has certain features, like the distribution of the back vents, the front plate holes, and the geometry of the diaphragm, that make it necessary to consider a full 3D geometry of the microspeaker in the vibroacoustic analysis.

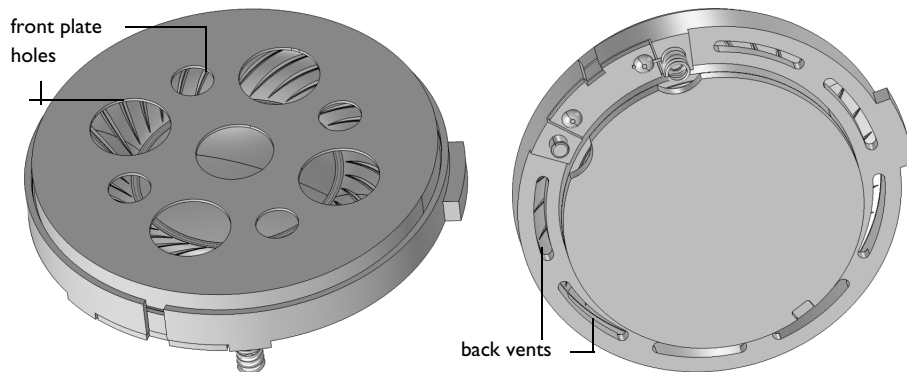

*Figure 2: Geometry of the OWS-1943T-8CP microspeaker from top and bottom views. The geometry is copyright by Ole Wolff Elektronik A/S.*

As shown in [Figure 2](#) and [Figure 3](#), the components that influence the electromagnetic field — that is, the pole piece, the magnets, and the voice coil — show axial symmetry. The axisymmetric assumption seems to be a valid approach for the electromagnetic analysis of the microspeaker.

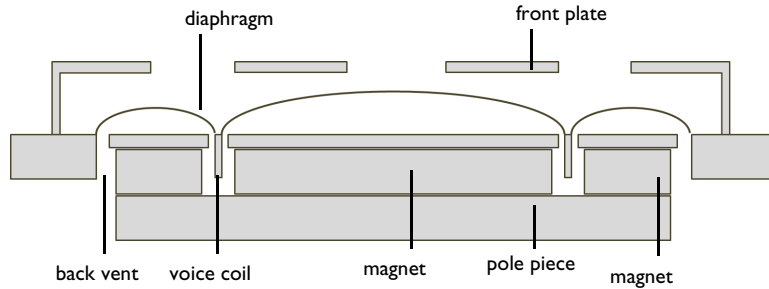

*Figure 3: Schematic cross-section view of the microspeaker.*

Due to the reduced dimensions of the microspeaker compared to the wavelengths solved for, it is assumed that all components will behave as acoustically rigid in the vibroacoustic analysis, except for the diaphragm and the voice coil.

#### **ELECTROMAGNETIC ANALYSIS**

The aim of this analysis is to obtain the BL factor of the microspeaker and the frequency dependent impedance characteristics of the voice coil and the electromagnetic circuit. The BL factor is the product of the magnetic field flux perpendicular to the coil and the total length of the coil.

The electromagnetic analysis of the microspeaker uses a **Small-Signal Analysis, Frequency Domain** study which includes two steps (automatically generated); a **Stationary** step where the stationary magnetic field generated by the magnets is considered, and a **Frequency Domain Perturbation**, where the voice coil is excited with a harmonic AC voltage and additional currents are induced in the electromagnetic circuit.

Due to the small influence of the voice coil position in the stationary magnetic field, instead of moving the coil and extracting the BL factor, the model uses logical operators and an integrand over the complete air and voice coil domain to account for the different positions of the voice coil as it moves. The BL factor is plotted versus the coil offset, a measurement of the distance between the current position of the voice coil and the resting position (see [Figure 6](#) in the results section).

It is worth highlighting that small imperfections due to surface roughness or thin glue layers between components in the electromagnetic circuit can have large influence on the BL factor. Therefore, this model uses the **Thin Low Permeability Gap** feature to add a small gap with air permeability to account for this. The areas where this feature have been applied are shown in [Figure 4](#).



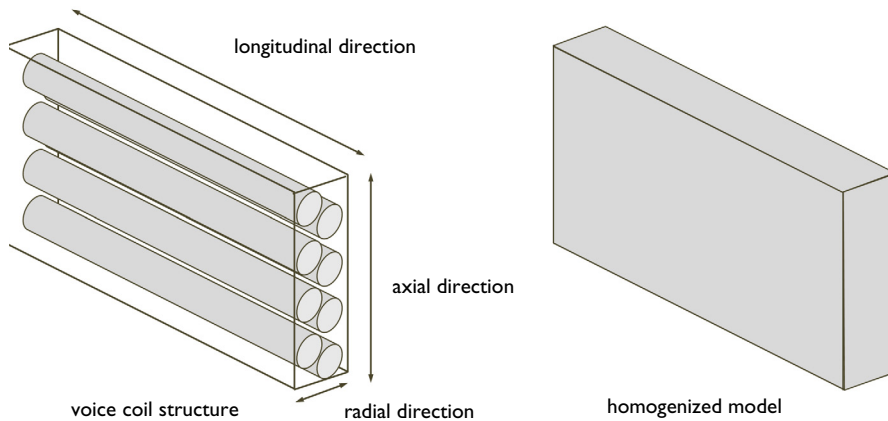

*Figure 5: Voice coil structure and its homogenized model.*

Ideally, this homogenized material should maintain the anisotropy of the voice coil in the different directions. The properties of this orthotropic equivalent material can be derived from a submodel or from testing. For the sake of simplicity in this tutorial, the homogenized voice coil has been assumed to have an isotropic behavior.

The compliance of the glue that attaches the voice coil to the diaphragm has not been specifically included in the model and that could also be a source for the small differences between the model and the measurements (see [Figure 7](#) in the results section).

### **VIBROACOUSTIC ANALYSIS**

During this step, the properties derived from the electromagnetic analysis are included in an electrical circuit and coupled to the other physics following the example shown in [Ref. 1](#). For the analysis, the speaker is placed in an infinite baffle test configuration. The **Exterior Field Calculation** feature is used to compute the response at a given distance in front of the speaker.

In the acoustic analysis, the damping in the diaphragm will be the main mode of dissipation of energy, so it is quite important to capture the correct damping of the diaphragm. In this tutorial, a constant isotropic loss factor is assumed for the diaphragm, but a frequency dependent damping is likely to produce better correlation. Possible ways to identify the diaphragm damping include testing the microspeaker in vacuum, to decouple the damping of the diaphragm from the damping of the air, or a dynamic testing of the diaphragm material.

## Results and Discussion

The measured and computed BL factors are shown in [Figure 6](#). The results show good agreement in the complete voice coil offset range. The model is using generic soft iron properties from the COMSOL material library. A possible way to improve the correlation of the BL curve is to measure the B-H curves of the iron used in the microspeaker and use this curve in the model.

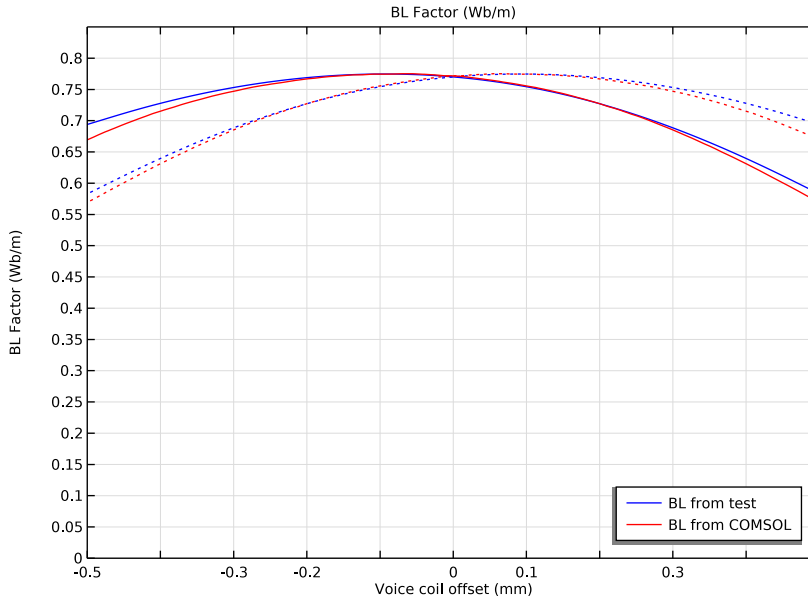

*Figure 6: Measured and computed BL factor.*

The measured and computed mechanical compliance  $C_{ms}(x)$  curves are shown in [Figure 7](#). The results show good agreement in the positive part of the voice coil offset. As discussed in the [Model Definition](#) section, the simplifications regarding the voice coil structure could be the main source of limited correlation on the negative part of the voice coil offset.

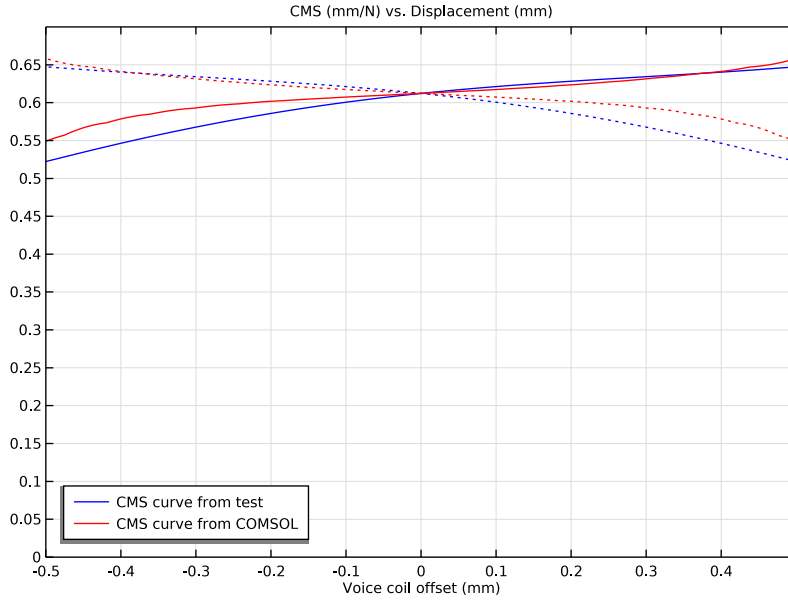
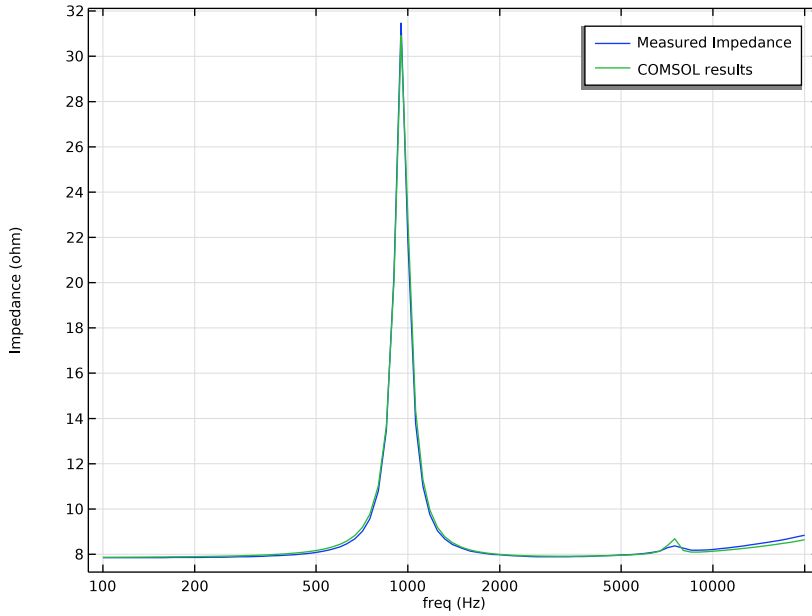

Figure 7: Measured and computed mechanical compliance  $C_{ms}$ .

Figure 8 shows the measured and the computed impedance of the electrical circuit. The main mechanical mode of the microspeaker, at around 950 Hz, shows a good match with the measurements both in terms of the frequency at which it is produced and the amount of damping of the mode. The response peak around 7500 Hz is caused by a radial mode combined with a rocking mode (see below) induced by the nonsymmetric distribution of the back vents. In the simulation results, the peak is relatively sharp while the measurements are showing a much more damped response.



*Figure 8: Measured and computed complex impedance of the electromagnetic system.*

Figure 9 shows the displacement at 7500 Hz, highlighting that the resonance is due to the excitation of a radial mode combined with a rocking mode induced by the nonsymmetric distribution of the back vents. The fact that the voice coil is deforming at this frequency and not acting as a solid body, suggest that correctly capturing the stiffness of the voice coil structure could improve the correlation of the frequency at which this resonance is produced.

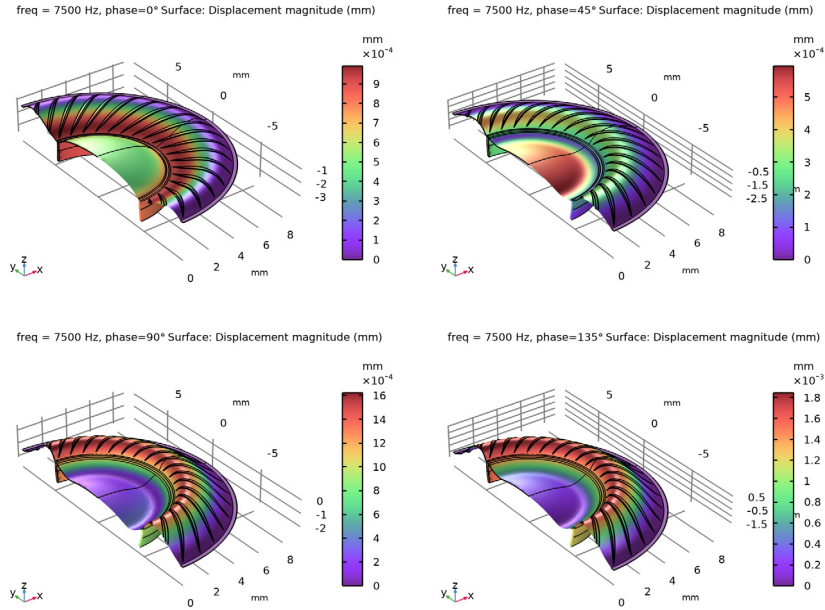

Figure 9: Displacement of the diaphragm and the voice coil at 7500 Hz.

The sound pressure level (SPL) evaluated 39.0 mm in front of the speaker is shown in Figure 10. The figure compares the simulation results and measurements. The COMSOL model presents a good level of correlation from low frequency up to 5000 Hz, with the curve showing a difference of 1.1 dB at the main resonance and 1.5 dB as the maximum difference. The response around 7500 Hz seems to be underdamped in the model, suggesting that thermoviscous damping in the air is relevant at that frequency. This was also indicated in the impedance curve in Figure 8.

To test this, a new study was created where **Thermoviscous Acoustics, Frequency Domain** was used to model the air domain behind the diaphragm and in the vents. The thermoviscous domain is easily coupled to the diaphragm and voice coil structures, and the pressure acoustics domains using the built-in multiphysics couplings (**Acoustic–Thermoviscous Acoustic Boundary** and **Thermoviscous Acoustic–Structure Boundary**). This part of the analysis is not included in the current model.

A finer mesh was used in this part of the model to properly resolve the thermoviscous boundary layers. Due to the additional degrees of freedom required to solve the problem, the resulting model was solved using a high-performance computer (HPC). This full

detailed setup requires about 95 GB of RAM while the model that only uses pressure acoustics fits in a machine with 16 GB of RAM. The SPL curve has been imported as a reference and is seen in Figure 10. Using a thermoviscous model that captures all thermoviscous losses will improve the correlation of the damping around the resonance at 7500 Hz.

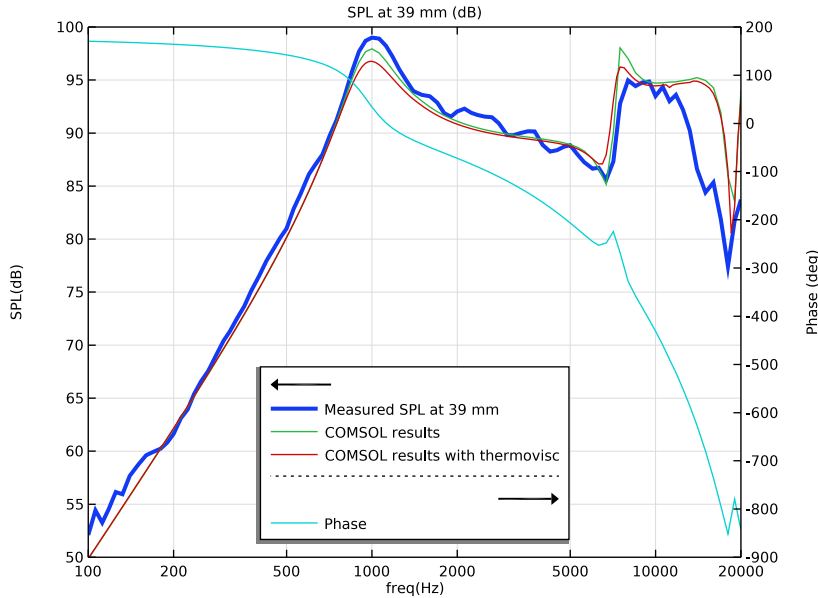

Figure 10: Measured and computed SPL, 39 mm front of the microspeaker. The result from a model with thermoviscous losses is also shown as a reference.

Both the pure pressure acoustics and the thermoviscous acoustics models still show significant differences in the range between 12 000 Hz and 18 500 Hz, caused by the difference in the circumferential modes. Again, the correlation is likely to improve if a better modeling of the voice coil structure is implemented. The model correctly captures the dip at the end of the acoustic range.

The tutorial has demonstrated that a good level of correlation is achieved with a relatively simple and a computationally affordable model using COMSOL Multiphysics. As with any other model, good material data is mandatory to produce meaningful predictions (both absolute and relative). It is also important to capture the thermoviscous effects in acoustic devices of reduced dimensions like this microspeaker.

## Reference

---

1. *Lumped Loudspeaker Driver*, from the COMSOL Application Library.
- 

**Application Library path:** Acoustics\_Module/Electroacoustic\_Transducers/  
ow\_microspeaker

---

## Modeling Instructions



---

From the **File** menu, choose **New**.

### NEW

In the **New** window, click  **Model Wizard**.

### MODEL WIZARD

- 1 In the **Model Wizard** window, click  **2D Axisymmetric**.
- 2 In the **Select Physics** tree, select **AC/DC > Electromagnetic Fields > Magnetic Fields (mf)**.
- 3 Click **Add**.
- 4 Click  **Study**.
- 5 In the **Select Study** tree, select **Preset Studies for Selected Physics Interfaces > Small-Signal Analysis, Frequency Domain**.
- 6 Click  **Done**.

### MAGNETIC FIELDS (MF)

#### *Ampère's Law in Fluids I*

- 1 In the **Physics** toolbar, click  **Domains** and choose **Ampère's Law in Fluids**.
- 2 In the **Settings** window for **Ampère's Law in Fluids**, locate the **Domain Selection** section.
- 3 From the **Selection** list, choose **All domains**.

In the next steps, import the parameters that will be used in the model and then import the measurements that will be used to validate the model.



### GLOBAL DEFINITIONS

#### *Parameters I*

- 1 In the **Model Builder** window, under **Global Definitions** click **Parameters I**.

- 2 In the **Settings** window for **Parameters**, locate the **Parameters** section.
- 3 Click  **Load from File**.
- 4 Browse to the model's Application Libraries folder and double-click the file `ow_microspeaker_parameters.txt`.

*Measured SPL at 39 mm*

- 1 In the **Home** toolbar, click  **Functions** and choose **Global > Interpolation**.
- 2 In the **Settings** window for **Interpolation**, type Measured SPL at 39 mm in the **Label** text field.
- 3 Locate the **Definition** section. Click  **Load from File**.
- 4 Browse to the model's Application Libraries folder and double-click the file `ow_microspeaker_spl_39mm_test.txt`.
- 5 In the **Function name** text field, type `SPL_Test`.
- 6 Locate the **Units** section. In the **Argument** table, enter the following settings:

Argument	Unit
t	Hz

- 7 In the **Function** table, enter the following settings:



Function	Unit
SPL_Test	dB

8 Click  **Plot**.

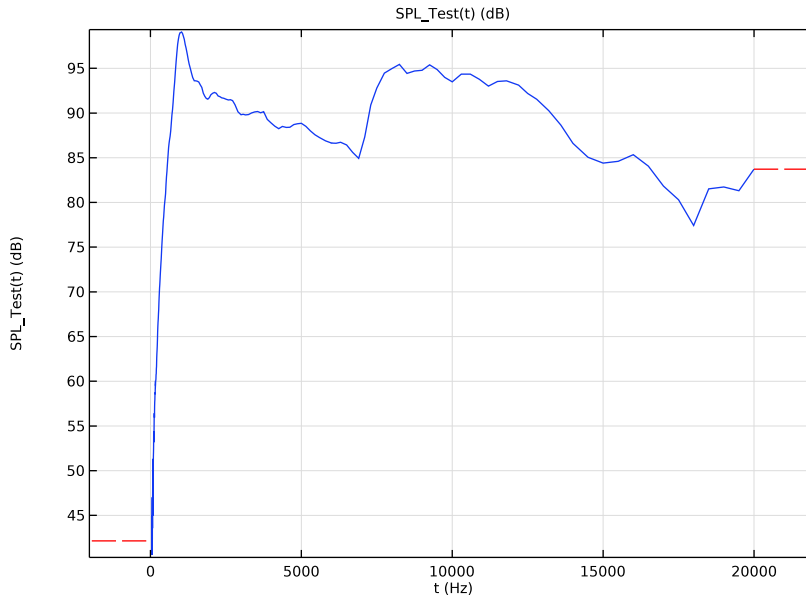
This plot shows the measured sound pressure level (SPL) 39 mm in front of the microspeaker.



#### *Measured BL curve*

- 1 In the **Home** toolbar, click  **Functions** and choose **Global > Interpolation**.
- 2 In the **Settings** window for **Interpolation**, type Measured BL curve in the **Label** text field.
- 3 Locate the **Definition** section. Click  **Load from File**.
- 4 Browse to the model's Application Libraries folder and double-click the file `ow_microspeaker_bl_test.txt`.
- 5 In the **Function name** text field, type `BL_Test`.
- 6 Locate the **Interpolation and Extrapolation** section. From the **Interpolation** list, choose **Piecewise cubic**.
- 7 From the **Extrapolation** list, choose **Linear**.
- 8 Locate the **Units** section. In the **Argument** table, enter the following settings:

<b>Argument</b>	<b>Unit</b>
<code>t</code>	<code>mm</code>

9 In the **Function** table, enter the following settings:



Function	Unit
BL_Test	Wb/m

10 Click  **Plot**.

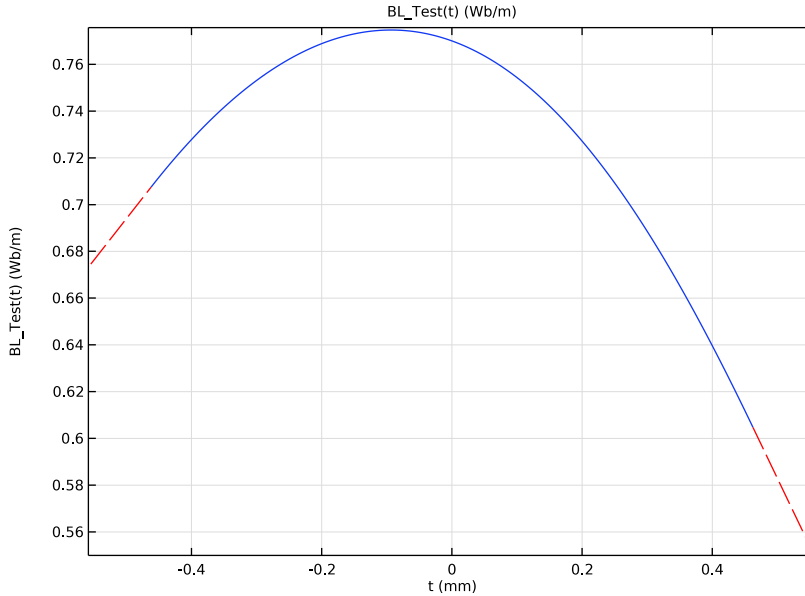
This plot shows the measured BL factor as a function of the coil displacement.



#### Measured Z curve

- 1 In the **Home** toolbar, click  **Functions** and choose **Global > Interpolation**.
- 2 In the **Settings** window for **Interpolation**, type Measured Z curve in the **Label** text field.
- 3 Locate the **Definition** section. Click  **Load from File**.
- 4 Browse to the model's Application Libraries folder and double-click the file `ow_microspeaker_z_test.txt`.
- 5 In the **Function name** text field, type `Z_Test`.
- 6 Locate the **Units** section. In the **Argument** table, enter the following settings:

Argument	Unit
t	Hz

7 In the **Function** table, enter the following settings:



Function	Unit
Z_Test	ohm

8 Click  **Plot**.

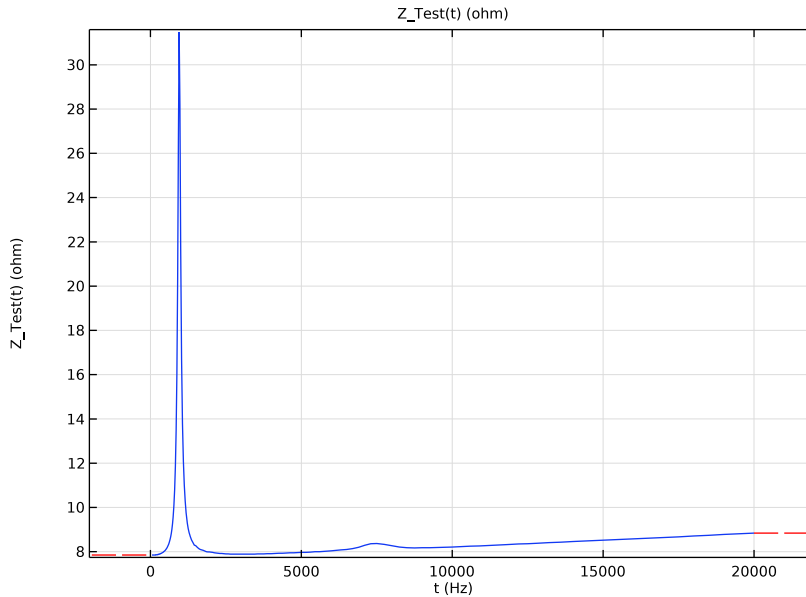
This plot shows the measured impedance as a function of the frequency.



#### *Measured CMS curve*

- 1 In the **Home** toolbar, click  **Functions** and choose **Global > Interpolation**.
- 2 In the **Settings** window for **Interpolation**, type Measured CMS curve in the **Label** text field.
- 3 Locate the **Definition** section. Click  **Load from File**.
- 4 Browse to the model's Application Libraries folder and double-click the file `ow_microspeaker_cms_test.txt`.
- 5 In the **Function name** text field, type `CMS_Test`.
- 6 Locate the **Interpolation and Extrapolation** section. From the **Interpolation** list, choose **Cubic spline**.
- 7 From the **Extrapolation** list, choose **Linear**.

8 Locate the **Units** section. In the **Argument** table, enter the following settings:

Argument	Unit
t	mm

9 In the **Function** table, enter the following settings:

Function	Unit
CMS_Test	mm/N

10 Click  **Plot**.

This plot shows the measured compliance ( $C_{ms}$ ) as a function of the coil displacement.

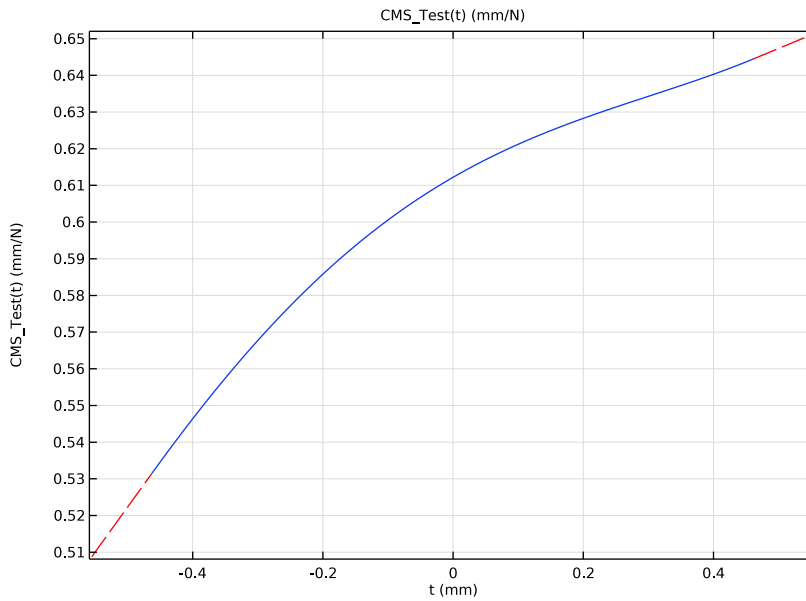

## ELECTROMAGNETIC ANALYSIS

As described in [Model Definition](#), the microspeaker presents axial symmetry for the electromagnetic field. Thus, this part of the analysis will be performed assuming axial symmetry.

## GEOMETRY I

- 1 In the **Model Builder** window, under **Component 1 (comp1)** click **Geometry 1**.
- 2 In the **Settings** window for **Geometry**, locate the **Units** section.

3 From the **Length unit** list, choose **mm**.

#### *Import 1 (imp1)*

1 In the **Home** toolbar, click  **Import**.

2 In the **Settings** window for **Import**, locate the **Source** section.

3 From the **Source** list, choose **COMSOL Multiphysics file**.

4 Click  **Browse**.

5 Browse to the model's Application Libraries folder and double-click the file `ow_microspeaker_axisymmetric.mphbin`.

6 Click  **Import**.

This 2D geometry has been generated through the use of the **Cross Section** feature, which uses a 3D geometry and a work plane to generate a 2D section. For the sake of simplicity, the result of some cleanup operations is directly imported as an external file.

## DEFINITIONS

#### *Variables 1*

1 In the **Model Builder** window, under **Component 1 (comp1)** right-click **Definitions** and choose **Variables**.

2 In the **Settings** window for **Variables**, locate the **Variables** section.

3 Click  **Load from File**.

4 Browse to the model's Application Libraries folder and double-click the file `ow_microspeaker_variables_2d.txt`.

The first two variables are logical operators that will be used to obtain the BL curve. The logical operators identify only the area that should contribute to the integral that is used to compute the BL factor. Read the documentation on the DEST built-in operator for further information. The third variable is the integrand used in the integral used to obtain the BL factor.

#### *Area to integrate BL*

1 In the **Definitions** toolbar, click  **Nonlocal Couplings** and choose **Integration**.

2 In the **Settings** window for **Integration**, type `Area` to integrate BL in the **Label** text field.

3 In the **Operator name** text field, type `int_BL`.



4 Select Domains 1 and 2 only.

5 Locate the **Advanced** section. In the **Integration order** text field, type 12.

6 Clear the **Compute integral in revolved geometry** checkbox.

As the coil does not have an influence on the static electromagnetic field, the model uses the logic operators to identify the position of the coil in the domain defined by the coil and the air.

#### ADD MATERIAL

- 1 In the **Materials** toolbar, click  **Add Material** to open the **Add Material** window.
- 2 Go to the **Add Material** window.
- 3 In the tree, select **Built-in > Air**.
- 4 Click the **Add to Component** button in the window toolbar.
- 5 In the tree, select **AC/DC > Soft Iron (With Losses)**.
- 6 Click the **Add to Component** button in the window toolbar.
- 7 In the **Materials** toolbar, click  **Add Material** to close the **Add Material** window.

#### MATERIALS

*Air (mat1)*

Select Domains 1 and 2 only.

*Soft Iron (With Losses) (mat2)*

- 1 In the **Model Builder** window, click **Soft Iron (With Losses) (mat2)**.
- 2 Select Domains 3, 5, and 7 only.

The next step defines the domains that will be part of the coil and pole pieces.

*Magnet*

- 1 In the **Model Builder** window, right-click **Materials** and choose **Blank Material**.
- 2 Select Domains 4 and 6 only.
- 3 In the **Settings** window for **Material**, type Magnet in the **Label** text field.
- 4 Click to expand the **Material Properties** section. In the **Material properties** tree, select **Electromagnetic Models > Remanent Flux Density > Remanent flux density norm (normBr)**.
- 5 Click  **Add to Material**.

6 Locate the **Material Contents** section. In the table, enter the following settings:

Property	Variable	Value	Unit	Property group
Recoil permeability	murec_iso ; murecii = murec_iso, murecij = 0		I	Remanent flux density
Remanent flux density norm	normBr	B0	T	Remanent flux density
Relative permeability	mur_iso ; murii = mur_iso, muriij = 0	1	I	Basic
Electric conductivity	sigma_iso ; sigmaii = sigma_iso, sigmaij = 0	0	S/m	Basic
Relative permittivity	epsilonIso ; epsilonRii = epsilonIso, epsilonRij = 0	1	I	Basic

## MAGNETIC FIELDS (MF)

### Domain Coil 1

- 1 In the **Physics** toolbar, click  **Domains** and choose **Domain Coil**.
- 2 Select Domain 2 only.
- 3 In the **Settings** window for **Domain Coil**, locate the **Coil** section.
- 4 From the **Conductor model** list, choose **Homogenized multiturn**.
- 5 From the **Coil excitation** list, choose **Voltage**.
- 6 In the  $V_{\text{coil}}$  text field, type linper (V0).
- 7 Locate the **Homogenized Conductor** section. In the  $N$  text field, type N0.
- 8 In the  $\sigma$  text field, type sigma\_wire.
- 9 From the list, choose **From diameter**.
- 10 In the  $d$  text field, type d\_wire.

### Ampère's Law First Magnet

- 1 In the **Physics** toolbar, click  **Domains** and choose **Ampère's Law in Solids**.

- 2 In the **Settings** window for **Ampère's Law in Solids**, type Ampère's Law First Magnet in the **Label** text field.
- 3 Select Domain 6 only.
- 4 Locate the **Constitutive Relation B-H** section. From the **Magnetization model** list, choose **Remanent flux density**.
- 5 Specify the **e** vector as

0	r
0	phi
1	z

#### *Ampère's Law Second Magnet*

- 1 In the **Physics** toolbar, click  **Domains** and choose **Ampère's Law in Solids**.
- 2 In the **Settings** window for **Ampère's Law in Solids**, type Ampère's Law Second Magnet in the **Label** text field.
- 3 Select Domain 4 only.
- 4 Locate the **Constitutive Relation B-H** section. From the **Magnetization model** list, choose **Remanent flux density**.
- 5 Specify the **e** vector as

0	r
0	phi
-1	z

Please note that the remanent flux of the two magnets faces opposite directions.

#### *Ampère's Law Soft Iron*

- 1 In the **Physics** toolbar, click  **Domains** and choose **Ampère's Law in Solids**.
- 2 In the **Settings** window for **Ampère's Law in Solids**, type Ampère's Law Soft Iron in the **Label** text field.
- 3 Select Domains 3, 5, and 7 only.
- 4 Locate the **Constitutive Relation B-H** section. From the **Magnetization model** list, choose **B-H curve**.

#### *Thin Low Permeability Gap 1*

- 1 In the **Physics** toolbar, click  **Boundaries** and choose **Thin Low Permeability Gap**.
- 2 Select Boundaries 13, 15, 21, and 23 only.

3 In the **Settings** window for **Thin Low Permeability Gap**, locate the **Thin Low Permeability Gap** section.

4 From the  $\mu_r$  list, choose **User defined**. In the  $d_s$  text field, type th\_gap.

The **Thin Low Permeability Gap** feature allows to capture the imperfect magnetic contact between the two domains due to the presence of glue or the surface roughness. The selection should look like that in [Figure 4](#).

#### **MESH 1**

1 In the **Model Builder** window, under **Component 1 (comp1)** click **Mesh 1**.

2 In the **Settings** window for **Mesh**, locate the **Sequence Type** section.

3 From the list, choose **User-controlled mesh**.

#### *Size*

1 In the **Model Builder** window, under **Component 1 (comp1)** > **Mesh 1** click **Size**.

2 In the **Settings** window for **Size**, locate the **Element Size** section.

3 Click the **Custom** button.

4 Locate the **Element Size Parameters** section. In the **Maximum element size** text field, type 1.

5 In the **Maximum element growth rate** text field, type 1.1.

6 Click  **Build Selected**.

#### *Mapped 1*

1 In the **Mesh** toolbar, click  **Mapped**.

2 In the **Settings** window for **Mapped**, locate the **Domain Selection** section.

3 From the **Geometric entity level** list, choose **Domain**.

4 Select Domains 4 and 6 only.

#### *Size 1*

1 Right-click **Mapped 1** and choose **Size**.

2 In the **Settings** window for **Size**, locate the **Element Size** section.

3 Click the **Custom** button.

4 Locate the **Element Size Parameters** section.

5 Select the **Maximum element size** checkbox. In the associated text field, type 0.1.

6 Click  **Build Selected**.

### *Size 1*

- 1 In the **Model Builder** window, right-click **Free Triangular 1** and choose **Size**.
- 2 In the **Settings** window for **Size**, locate the **Geometric Entity Selection** section.
- 3 From the **Geometric entity level** list, choose **Boundary**.
- 4 Select Boundaries 18, 19, and 22 only.
- 5 Locate the **Element Size** section. Click the **Custom** button.
- 6 Locate the **Element Size Parameters** section.
- 7 Select the **Maximum element size** checkbox. In the associated text field, type 0.02.
- 8 Click  **Build Selected**.

### *Boundary Layers 1*

- 1 In the **Mesh** toolbar, click  **Boundary Layers**.
- 2 In the **Settings** window for **Boundary Layers**, locate the **Domain Selection** section.
- 3 From the **Geometric entity level** list, choose **Domain**.
- 4 Select Domains 3, 5, and 7 only.

### *Boundary Layer Properties*

- 1 In the **Model Builder** window, click **Boundary Layer Properties**.
- 2 Select Boundaries 11, 13, 15, 16, 18, 19, 21–25, 27, and 28 only.
- 3 In the **Settings** window for **Boundary Layer Properties**, locate the **Layers** section.
- 4 From the **Thickness specification** list, choose **First layer**.
- 5 In the **Thickness** text field, type 0.005.

6 Click  **Build All**.

The mesh is manually set up to make sure that a finer mesh is present in the iron domains. The resulting mesh should look like this:

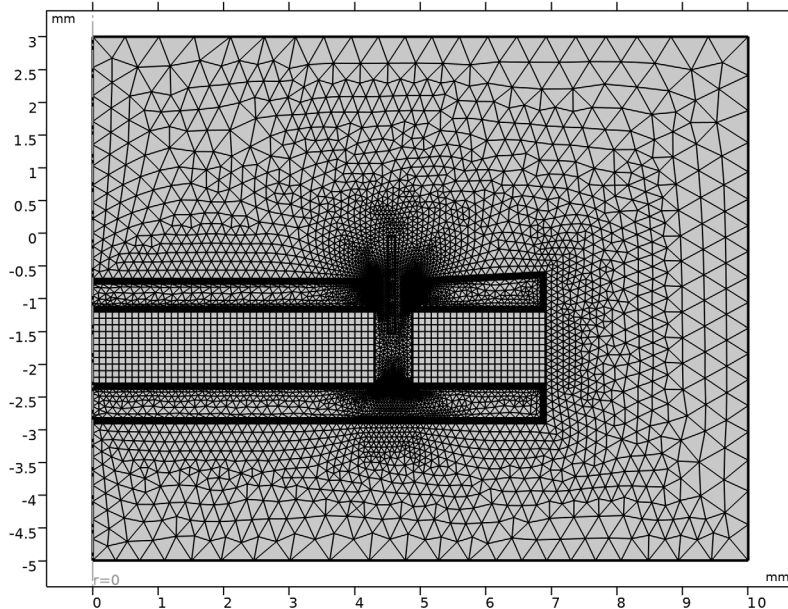

## STUDY 1 - AXISYMMETRIC MAGNETIC ANALYSIS

- 1 In the **Model Builder** window, click **Study 1**.
- 2 In the **Settings** window for **Study**, type Study 1 - Axisymmetric Magnetic Analysis in the **Label** text field.



### Step 2: Frequency-Domain Perturbation

- 1 In the **Model Builder** window, under **Study 1 - Axisymmetric Magnetic Analysis** click **Step 2: Frequency-Domain Perturbation**.
- 2 In the **Settings** window for **Frequency-Domain Perturbation**, locate the **Study Settings** section.
- 3 Click  **Range**.
- 4 In the **Range** dialog, choose **Logarithmic** from the **Entry method** list.
- 5 In the **Start** text field, type 100.
- 6 In the **Stop** text field, type 20000.
- 7 In the **Steps per decade** text field, type 10.

- 8 Click **Replace**.
- 9 In the **Study** toolbar, click  **Compute**.

## RESULTS

### *Coil Displacement*

- 1 In the **Results** toolbar, click  **Cut Line 2D**.
- 2 In the **Settings** window for **Cut Line 2D**, type *Coil Displacement* in the **Label** text field.
- 3 Locate the **Data** section. From the **Dataset** list, choose **Study 1 - Axisymmetric Magnetic Analysis/Solution Store 1 (sol2)**.
- 4 Locate the **Line Data** section. In row **Point 1**, set **r** to  $(4.5+4.61307)/2$ .
- 5 In row **Point 1**, set **z** to  $(-1.53-0.05)/2-0.5$ .
- 6 In row **Point 2**, set **r** to  $(4.5+4.61307)/2$ .
- 7 In row **Point 2**, set **z** to  $(-1.53-0.05)/2+0.5$ .
- 8 Click  **Plot**.

This line defines the center of the coil as it travels 0.5 mm in both directions from the initial position across the *z*-coordinate.

### *Coil Properties from COMSOL*

- 1 In the **Results** toolbar, click  **ID Plot Group**.
- 2 In the **Settings** window for **ID Plot Group**, type *Coil Properties from COMSOL* in the **Label** text field.
- 3 Locate the **Plot Settings** section. Select the **Two y-axes** checkbox.
- 4 Locate the **Axis** section. Select the **x-axis log scale** checkbox.
- 5 Select the **Secondary y-axis log scale** checkbox.
- 6 Locate the **Legend** section. From the **Position** list, choose **Upper left**.

### *Resistance*

- 1 Right-click **Coil Properties from COMSOL** and choose **Global**.
- 2 In the **Settings** window for **Global**, type *Resistance* in the **Label** text field.
- 3 Locate the **y-Axis Data** section. In the table, enter the following settings:

Expression	Unit	Description
$\text{real}(\text{mf.VCoil}_1/\text{mf.ICoil}_1)$	$\Omega$	Resistance

### *Reactance*

- 1 In the **Model Builder** window, right-click **Coil Properties from COMSOL** and choose **Global**.

- In the **Settings** window for **Global**, type Reactance in the **Label** text field.
- Locate the **y-Axis** section. Select the **Plot on secondary y-axis** checkbox.
- Locate the **y-Axis Data** section. In the table, enter the following settings:

Expression	Unit	Description
$\text{imag}(\text{mf.VCoil}_1/\text{mf.ICoil}_1)$	$\Omega$	Reactance

- In the **Coil Properties from COMSOL** toolbar, click  **Plot**.

The plot shows the impedance due to the voice coil and electromagnetic circuit. It will be combined with the other physics to generate a representative model of the microspeaker.

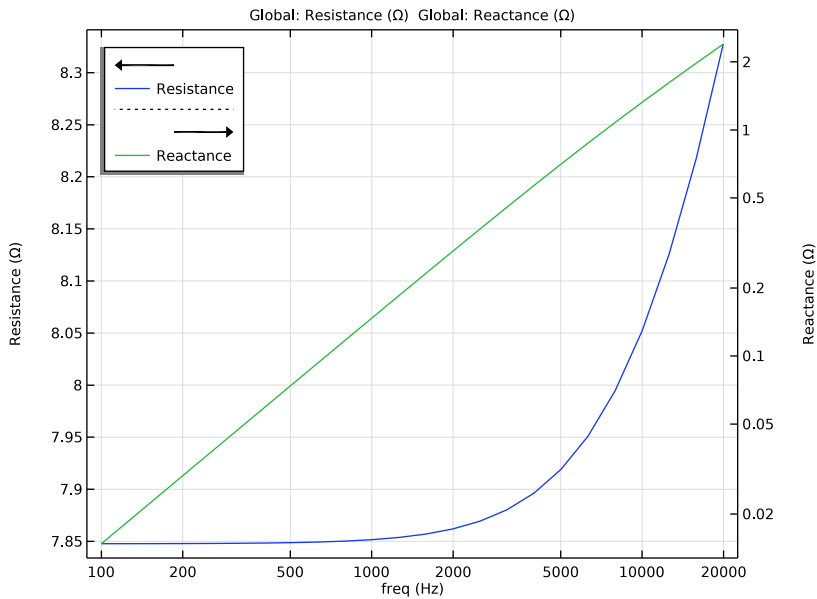

### BL Factor

- In the **Results** toolbar, click  **ID Plot Group**.
- In the **Settings** window for **ID Plot Group**, type BL Factor in the **Label** text field.
- Locate the **Data** section. From the **Dataset** list, choose **Coil Displacement**.
- Click to expand the **Title** section. Locate the **Plot Settings** section.
- Select the **x-axis label** checkbox. In the associated text field, type Voice coil offset (mm).

- 6 Locate the **Title** section. From the **Title type** list, choose **Manual**.
- 7 In the **Title** text area, type BL Factor (Wb/m).
- 8 Locate the **Axis** section. Select the **Manual axis limits** checkbox.
- 9 In the **x minimum** text field, type -0.5.
- 10 In the **x maximum** text field, type 0.5.
- 11 In the **y minimum** text field, type 0.
- 12 In the **y maximum** text field, type 0.85.
- 13 Locate the **Legend** section. From the **Position** list, choose **Lower right**.

*BL from test*

- 1 Right-click **BL Factor** and choose **Line Graph**.
- 2 In the **Settings** window for **Line Graph**, type BL from test in the **Label** text field.
- 3 Locate the **y-Axis Data** section. In the **Expression** text field, type  $BL\_Test(z - (-1.53[mm] - 0.05[mm]) / 2)$ .
- 4 Select the **Description** checkbox. In the associated text field, type BL Factor.
- 5 Locate the **x-Axis Data** section. From the **Parameter** list, choose **Expression**.
- 6 In the **Expression** text field, type  $z - (-1.53[mm] - 0.05[mm]) / 2$ .
- 7 Select the **Description** checkbox. In the associated text field, type Coil Offset.
- 8 Click to expand the **Coloring and Style** section. From the **Color** list, choose **Blue**.
- 9 Click to expand the **Legends** section. Select the **Show legends** checkbox.
- 10 Find the **Include** subsection. Select the **Label** checkbox.
- 11 Clear the **Solution** checkbox.

*BL from test (inverted)*

- 1 In the **Model Builder** window, right-click **BL Factor** and choose **Line Graph**.
- 2 In the **Settings** window for **Line Graph**, type BL from test (inverted) in the **Label** text field.
- 3 Locate the **y-Axis Data** section. In the **Expression** text field, type  $BL\_Test(z - (-1.53[mm] - 0.05[mm]) / 2)$ .
- 4 Select the **Description** checkbox. In the associated text field, type BL Factor.
- 5 Locate the **x-Axis Data** section. From the **Parameter** list, choose **Expression**.
- 6 In the **Expression** text field, type  $-(z - (-1.53[mm] - 0.05[mm]) / 2)$ .
- 7 Select the **Description** checkbox. In the associated text field, type Coil Offset.

8 Locate the **Coloring and Style** section. Find the **Line style** subsection. From the **Line** list, choose **Dotted**.

9 From the **Color** list, choose **Blue**.

*BL from COMSOL*

1 Right-click **BL Factor** and choose **Line Graph**.

2 In the **Settings** window for **Line Graph**, type BL from COMSOL in the **Label** text field.

3 Locate the **y-Axis Data** section. In the **Expression** text field, type -  
 $\text{int\_BL}(\text{BL\_integrand}*\text{coil\_location\_r}*\text{coil\_location\_z})$ .

4 Select the **Description** checkbox. In the associated text field, type BL Factor.

5 Locate the **x-Axis Data** section. From the **Parameter** list, choose **Expression**.

6 In the **Expression** text field, type  $z - (-1.53[\text{mm}] - 0.05[\text{mm}]) / 2$ .

7 Select the **Description** checkbox. In the associated text field, type Coil Offset.

8 Locate the **Coloring and Style** section. From the **Color** list, choose **Red**.

9 Locate the **Legends** section. Select the **Show legends** checkbox.

10 Find the **Include** subsection. Select the **Label** checkbox.

11 Clear the **Solution** checkbox.

Through the use of the logical operators modifying the integrand, only the area of the coil around the point of interest is considered in the integration.

*BL from COMSOL (inverted)*

1 Right-click **BL Factor** and choose **Line Graph**.

2 In the **Settings** window for **Line Graph**, type BL from COMSOL (inverted) in the **Label** text field.

3 Locate the **y-Axis Data** section. In the **Expression** text field, type -  
 $\text{int\_BL}(\text{BL\_integrand}*\text{coil\_location\_r}*\text{coil\_location\_z})$ .

4 Select the **Description** checkbox. In the associated text field, type BL Factor.

5 Click to expand the **Title** section. From the **Title type** list, choose **None**.

6 Locate the **x-Axis Data** section. From the **Parameter** list, choose **Expression**.

7 In the **Expression** text field, type  $-(z - (-1.53[\text{mm}] - 0.05[\text{mm}]) / 2)$ .

8 Select the **Description** checkbox. In the associated text field, type Coil Offset.

9 Locate the **Coloring and Style** section. Find the **Line style** subsection. From the **Line** list, choose **Dotted**.

10 From the **Color** list, choose **Red**.

11 In the **BL Factor** toolbar, click  **Plot**.

The plot should look like [Figure 6](#).

*BL Factor, Coil Properties from COMSOL, Magnetic Flux Density (mf), Magnetic Flux Density, Revolved Geometry (mf)*

1 In the **Model Builder** window, under **Results**, Ctrl-click to select **Magnetic Flux Density (mf)**, **Magnetic Flux Density, Revolved Geometry (mf)**, **Coil Properties from COMSOL**, and **BL Factor**.

2 Right-click and choose **Group**.

*Postprocessing - Electromagnetic analysis*

1 In the **Settings** window for **Group**, type Postprocessing - Electromagnetic analysis in the **Label** text field.

The electromagnetic results are now under a single group, which makes easier the navigation between results of different studies.

*Evaluation Group - Coil Properties*

1 In the **Results** toolbar, click  **Evaluation Group**.

2 In the **Settings** window for **Evaluation Group**, type Evaluation Group - Coil Properties in the **Label** text field.

*Global Evaluation 1*

1 Right-click **Evaluation Group - Coil Properties** and choose **Global Evaluation**.

2 In the **Settings** window for **Global Evaluation**, locate the **Expressions** section.

3 In the table, enter the following settings:

Expression	Unit	Description
$\text{real}(\text{mf.VCoil}_1/\text{mf.ICoil}_1)$	$\Omega$	Resistance
$\text{imag}(\text{mf.VCoil}_1/\text{mf.ICoil}_1)$	$\Omega$	Reactance

4 In the **Evaluation Group - Coil Properties** toolbar, click  **Evaluate**.

The evaluation group is used to bring the impedance of the voice coil and the electromagnetic circuit into an electrical circuit connected to the 3D model.

*Evaluation Group - BL Factor*

1 In the **Results** toolbar, click  **Evaluation Group**.

2 In the **Settings** window for **Evaluation Group**, type Evaluation Group - BL Factor in the **Label** text field.

3 Locate the **Data** section. From the **Parameter selection (freq)** list, choose **First**.

### Surface Average 1

- 1 Right-click **Evaluation Group - BL Factor** and choose **Average > Surface Average**.
- 2 Select Domain 2 only.
- 3 In the **Settings** window for **Surface Average**, locate the **Expressions** section.
- 4 In the table, enter the following settings:

Expression	Unit	Description
$-mf.Br*N0*2*pi*r$	Wb/m	

- 5 From the **Expression evaluated for** list, choose **Static solution**.
- 6 Locate the **Integration Settings** section. Clear the **Compute volume integral** checkbox.
- 7 In the **Evaluation Group - BL Factor** toolbar, click  **Evaluate**.  
This is the value of the BL factor predicted by the model that will be used the electrical circuit to the other physics.

## GLOBAL DEFINITIONS

### Coil inductance from axisymmetric model

- 1 In the **Home** toolbar, click **f(x) Functions** and choose **Global > Interpolation**.
- 2 In the **Settings** window for **Interpolation**, type Coil inductance from axisymmetric model in the **Label** text field.
- 3 Locate the **Definition** section. From the **Data source** list, choose **Result table**.
- 4 Locate the **Data Column Settings** section. In the table, click to select the cell at row number 1 and column number 1.
- 5 In the **Unit** text field, type Hz.
- 6 In the table, click to select the cell at row number 2 and column number 1.
- 7 In the **Name** text field, type Zreal.
- 8 In the **Unit** text field, type ohm.
- 9 In the table, enter the following settings:

Columns	Type	Settings
Reactance ( $\Omega$ )	Function values	Function name=Zimag

- 10 In the **Name** text field, type Zimag.
- 11 In the **Unit** text field, type ohm.

12 Click  **Plot**.

The plot should look like this:

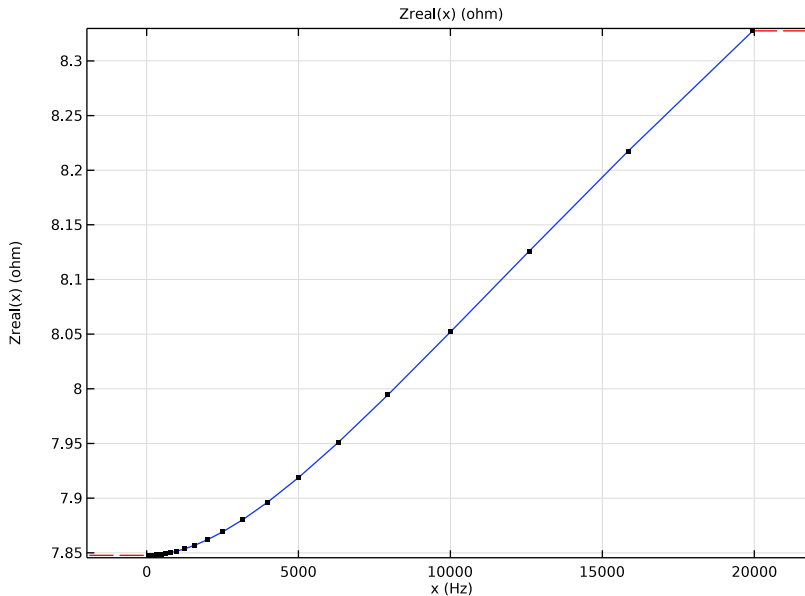

*Parameters 1*

This is the value of the BL factor computed through the evaluation group previously.

### ADD COMPONENT

In the **Model Builder** window, right-click the root node and choose **Add Component > 3D**.

### GEOMETRY 2

1 In the **Settings** window for **Geometry**, locate the **Units** section.

2 From the **Length unit** list, choose **mm**.

*Import 1 (impl)*



1 In the **Geometry** toolbar, click  **Import**.

2 In the **Settings** window for **Import**, locate the **Source** section.

3 From the **Source** list, choose **COMSOL Multiphysics file**.

4 Click  **Browse**.

5 Browse to the model's Application Libraries folder and double-click the file `ow_microspeaker_geometry.mphbin`.

- 6 Click  **Import**.
- 7 Click the  **Wireframe Rendering** button in the **Graphics** toolbar.  
Disable the analysis of the geometry as the remaining small geometric details can be kept.
- 8 In the **Model Builder** window, click **Geometry 2**.
- 9 In the **Settings** window for **Geometry**, locate the **Cleanup** section.
- 10 Clear the **Automatic detection of small details** checkbox.
- 11 In the **Geometry** toolbar, click  **Build All**.

## DEFINITIONS (COMP2)

### *Variables 2*

- 1 In the **Model Builder** window, under **Component 2 (comp2)** right-click **Definitions** and choose **Variables**.
- 2 In the **Settings** window for **Variables**, locate the **Variables** section.
- 3 Click  **Load from File**.
- 4 Browse to the model's Application Libraries folder and double-click the file `ow_microspeaker_variables_3d.txt`.  
The first and fourth variables are used to update the density of the voice coil to make sure that the mass of the voice coil and the diaphragm match the measured mass. The second variable is the average velocity of the coil, which is used to couple the electrical circuit with the other physics. The third variable is just a measurement of the displacement of the coil. The fifth variable is just the total acoustic energy traveling through a surface and will be used to confirm the validity of the PML.

### *Diaphragm triangular mesh*

- 1 In the **Definitions** toolbar, click  **Explicit**.
- 2 In the **Settings** window for **Explicit**, type Diaphragm triangular mesh in the **Label** text field.
- 3 Locate the **Input Entities** section. From the **Geometric entity level** list, choose **Boundary**.
- 4 Select Boundaries 31, 32, 36–44, 50, 53, 55, 58–60, 63–65, 73, 74, 77, 83–85, 88–90, 93–98, 122–124, 135, 136, 143, 146–156, 162–164, 171–179, 225, 247, 251–

254, 257, 258, 270–281, 283, 285, 286, 291–296, 299–301, 309–314, 316–321, and 323–334 only.

The selection should look like this:

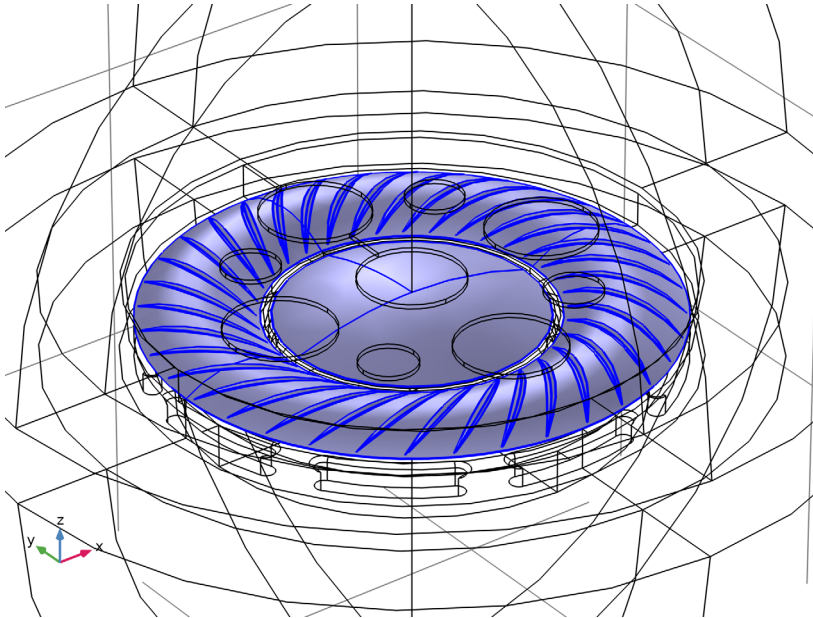

#### *Diaphragm mapped mesh*

- 1 In the **Definitions** toolbar, click  **Explicit**.
- 2 In the **Settings** window for **Explicit**, type Diaphragm mapped mesh in the **Label** text field.
- 3 Locate the **Input Entities** section. From the **Geometric entity level** list, choose **Boundary**.
- 4 Select Boundaries 22, 23, 110, 117, 134, 191, 204, 206, 211, and 262 only.

#### *Diaphragm*

- 1 In the **Definitions** toolbar, click  **Union**.
- 2 In the **Settings** window for **Union**, type Diaphragm in the **Label** text field.
- 3 Locate the **Geometric Entity Level** section. From the **Level** list, choose **Boundary**.
- 4 Locate the **Input Entities** section. Under **Selections to add**, click **+ Add**.
- 5 In the **Add** dialog, in the **Selections to add** list, choose **Diaphragm triangular mesh** and **Diaphragm mapped mesh**.
- 6 Click **OK**.

### Coil

- 1 In the **Definitions** toolbar, click  **Explicit**.
- 2 In the **Settings** window for **Explicit**, type **Coil** in the **Label** text field.
- 3 Select Domains 12 and 13 only.

The selection should look like this:

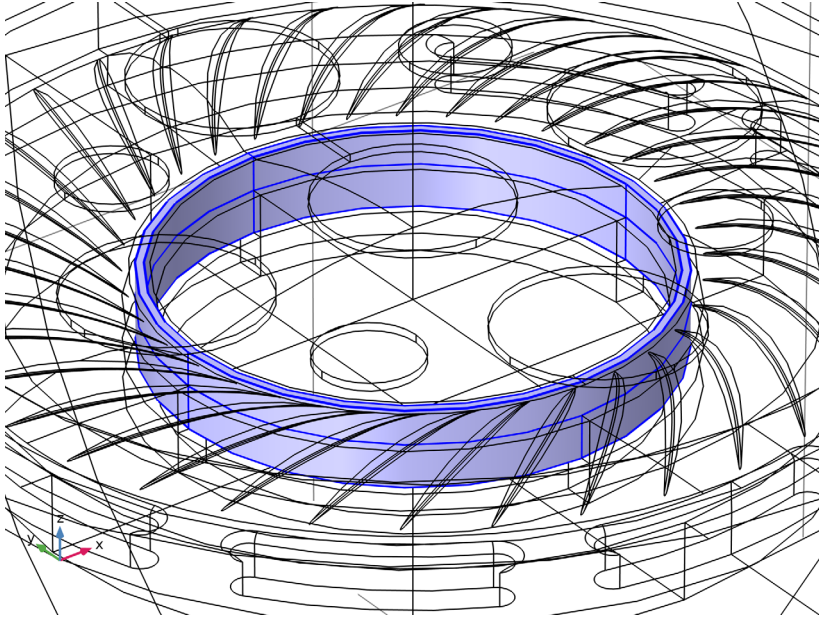

### Air

- 1 In the **Definitions** toolbar, click  **Explicit**.
- 2 In the **Settings** window for **Explicit**, type **Air** in the **Label** text field.

3 Select Domains 1–11 and 14–24 only.

The selection should look like this:

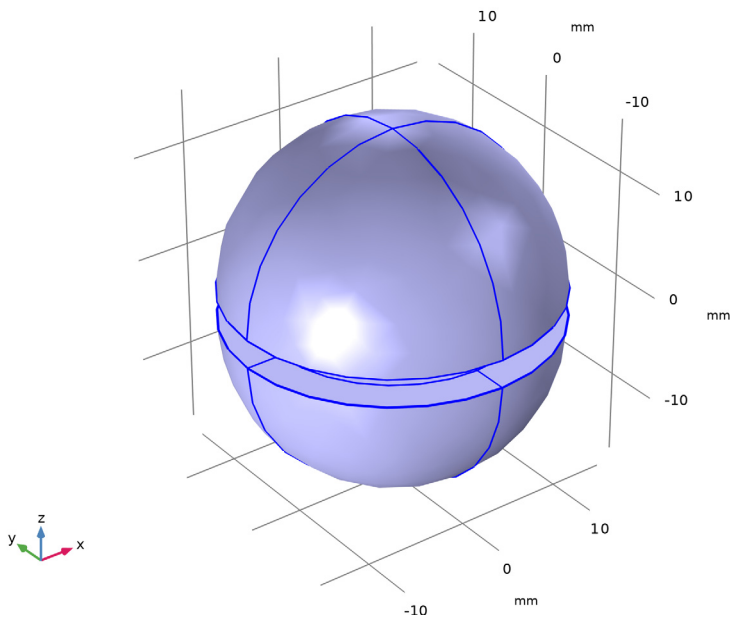

*PML Top*

1 In the **Definitions** toolbar, click  **Explicit**.

2 In the **Settings** window for **Explicit**, type PML Top in the **Label** text field.

3 Select Domain 2 only.

The selection should look like this:

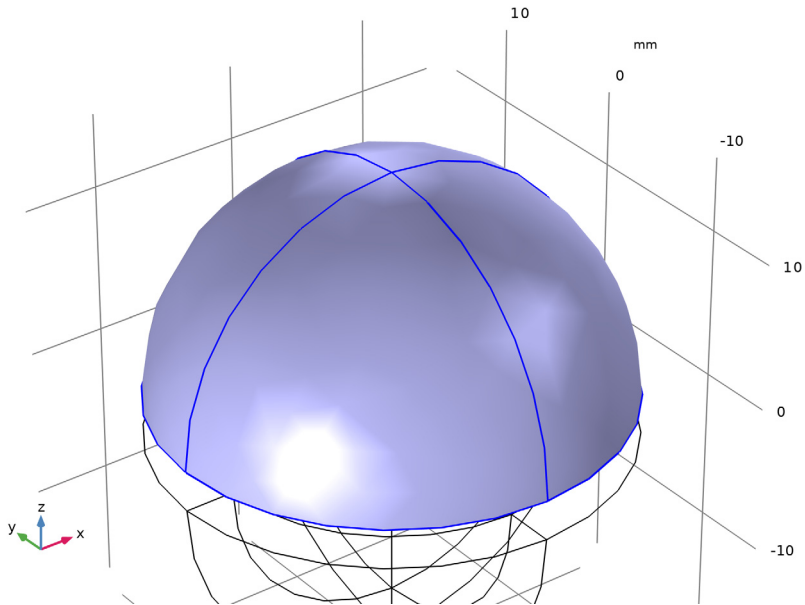

*PML Bottom*

1 In the **Definitions** toolbar, click  **Explicit**.

2 In the **Settings** window for **Explicit**, type PML Bottom in the **Label** text field.

3 Select Domain 1 only.

The selection should look like this:

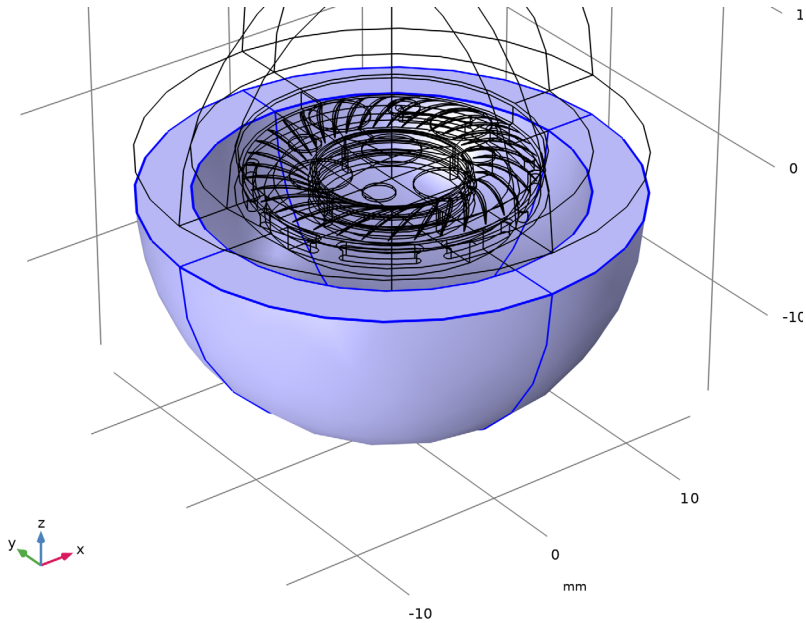

#### *Exterior Field*



- 1 In the **Definitions** toolbar, click  **Explicit**.
- 2 In the **Settings** window for **Explicit**, type Exterior Field in the **Label** text field.
- 3 Locate the **Input Entities** section. From the **Geometric entity level** list, choose **Boundary**.

- 4 Select Boundaries 15, 16, 189, and 227 only.

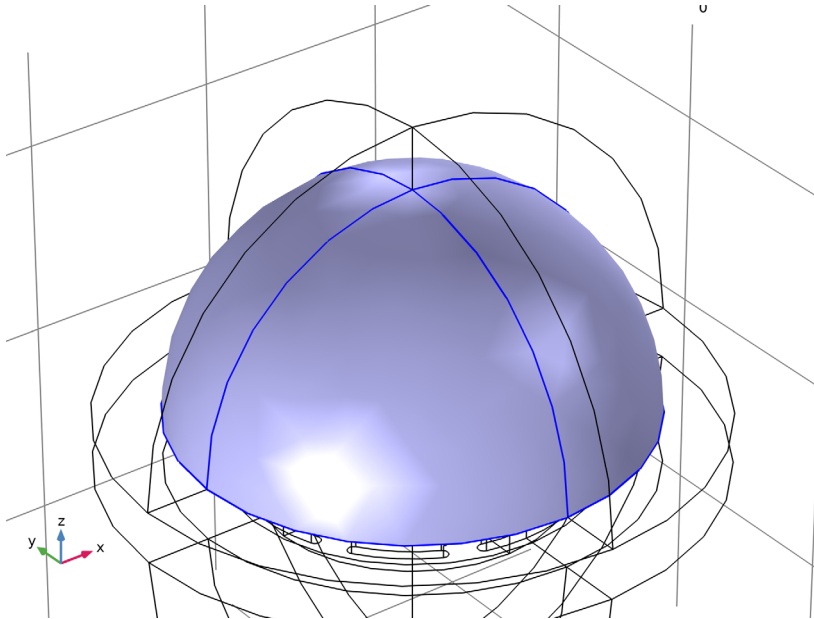
The selection should look like this:



#### *Air Without PML*

- 1 In the **Definitions** toolbar, click  **Difference**.
- 2 In the **Settings** window for **Difference**, type Air Without PML in the **Label** text field.
- 3 Locate the **Input Entities** section. Under **Selections to add**, click  **Add**.
- 4 In the **Add** dialog, select **Air** in the **Selections to add** list.
- 5 Click **OK**.
- 6 In the **Settings** window for **Difference**, locate the **Input Entities** section.
- 7 Under **Selections to subtract**, click  **Add**.
- 8 In the **Add** dialog, in the **Selections to subtract** list, choose **PML Top** and **PML Bottom**.
- 9 Click **OK**.

#### *Inner gap*

- 1 In the **Definitions** toolbar, click  **Explicit**.
- 2 In the **Settings** window for **Explicit**, type Inner gap in the **Label** text field.

3 Select Domains 14, 15, 19, and 20 only.

The selection should look like this:

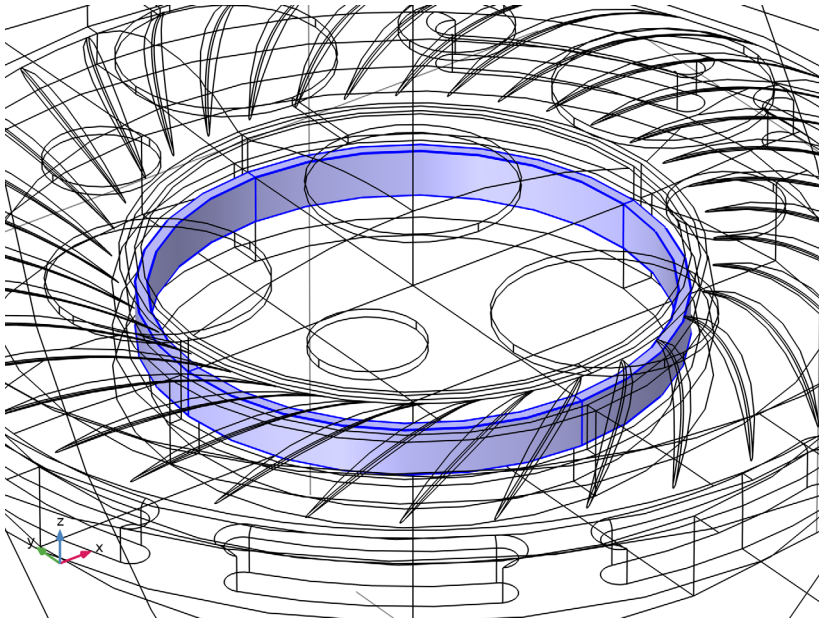

*Outer gap*

1 In the **Definitions** toolbar, click  **Explicit**.

2 In the **Settings** window for **Explicit**, type Outer gap in the **Label** text field.

3 Select Domains 10, 11, 18, and 21 only.

The selection should look like this:

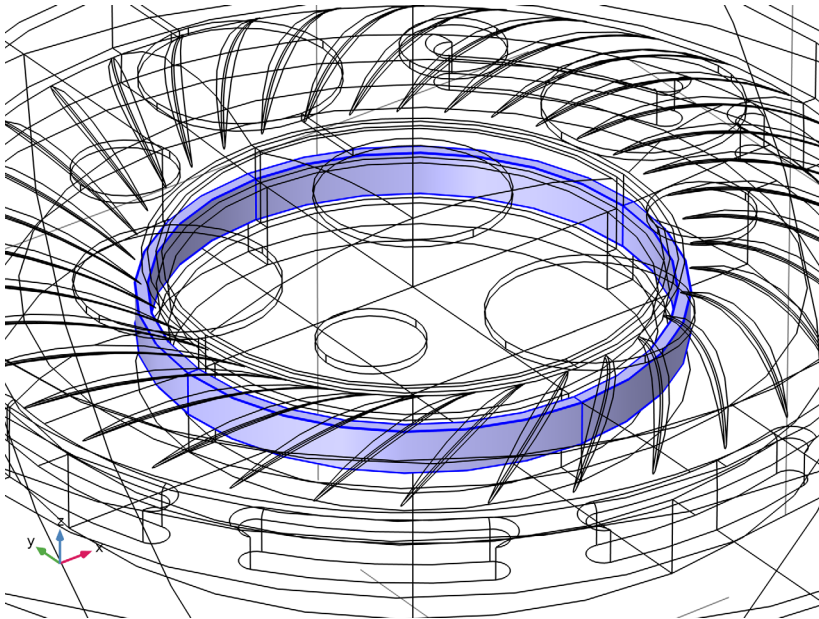

*Outer channels*

- 1 In the **Definitions** toolbar, click  **Explicit**.
- 2 In the **Settings** window for **Explicit**, type Outer channels in the **Label** text field.

3 Select Domains 5, 7, 8, 17, and 22–24 only.

The selection should look like this:

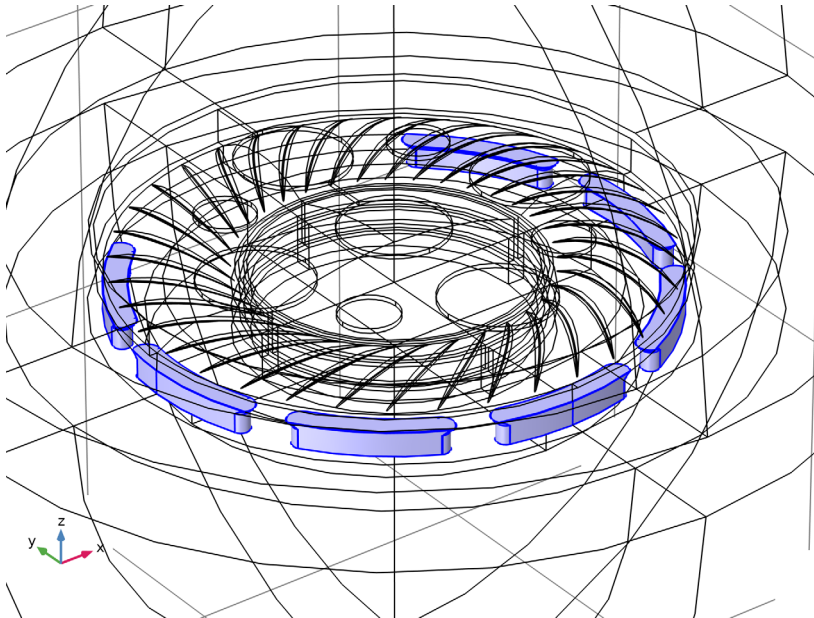

The variable utilities menu grant access to the **Mass Properties** features that will be used to track the mass of the coil and the diaphragm.

#### *Coil Mass*

- 1 Right-click **Definitions** and choose **Physics Utilities > Mass Properties**.
- 2 In the **Settings** window for **Mass Properties**, type Coil Mass in the **Label** text field.
- 3 In the **Name** text field, type mass\_coil.
- 4 Locate the **Source Selection** section. From the **Selection** list, choose **Coil**.

#### *Diaphragm Mass*

- 1 Right-click **Definitions** and choose **Physics Utilities > Mass Properties**.
- 2 In the **Settings** window for **Mass Properties**, type Diaphragm Mass in the **Label** text field.
- 3 In the **Name** text field, type mass\_diaphragm.
- 4 Locate the **Source Selection** section. From the **Geometric entity level** list, choose **Boundary**.
- 5 From the **Selection** list, choose **Diaphragm**.
- 6 Locate the **Density** section. From the **Density source** list, choose **From physics interface**.

### Coil Average

- 1 In the **Definitions** toolbar, click  **Nonlocal Couplings** and choose **Average**.
- 2 In the **Settings** window for **Average**, type Coil Average in the **Label** text field.
- 3 In the **Operator name** text field, type ave\_coil.
- 4 Locate the **Source Selection** section. From the **Selection** list, choose **Coil**.

### PML Top Integral

- 1 In the **Definitions** toolbar, click  **Nonlocal Couplings** and choose **Integration**.
- 2 In the **Settings** window for **Integration**, type PML Top Integral in the **Label** text field.
- 3 In the **Operator name** text field, type int\_PML\_Top.
- 4 Locate the **Source Selection** section. From the **Geometric entity level** list, choose **Boundary**.
- 5 Select Boundaries 15, 16, 189, and 227 only.

The selection should look like this:

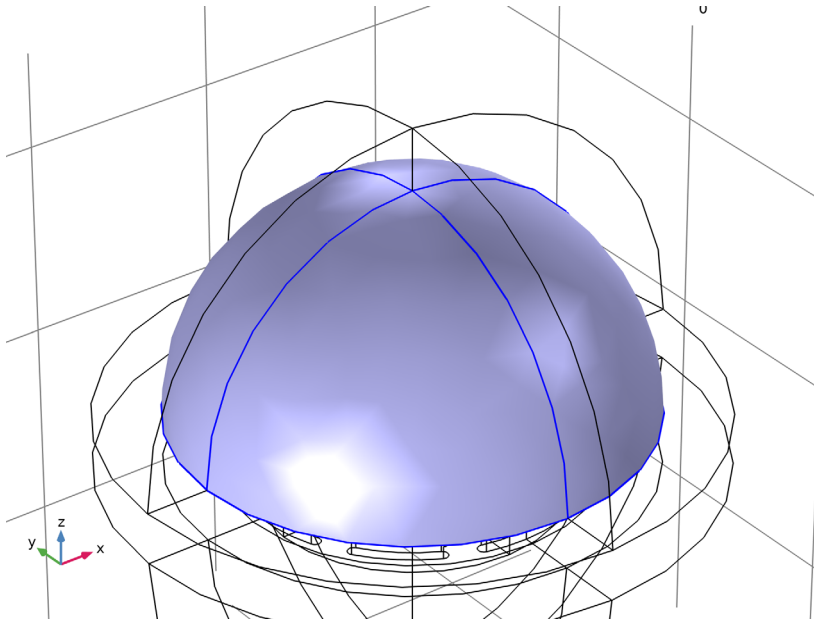

### PML Bottom Integral



- 1 In the **Definitions** toolbar, click  **Nonlocal Couplings** and choose **Integration**.
- 2 In the **Settings** window for **Integration**, type PML Bottom Integral in the **Label** text field.

- 3 In the **Operator name** text field, type `int_PML_Bottom`.
- 4 Locate the **Source Selection** section. From the **Geometric entity level** list, choose **Boundary**.
- 5 Select Boundaries 11, 12, 187, and 220 only.

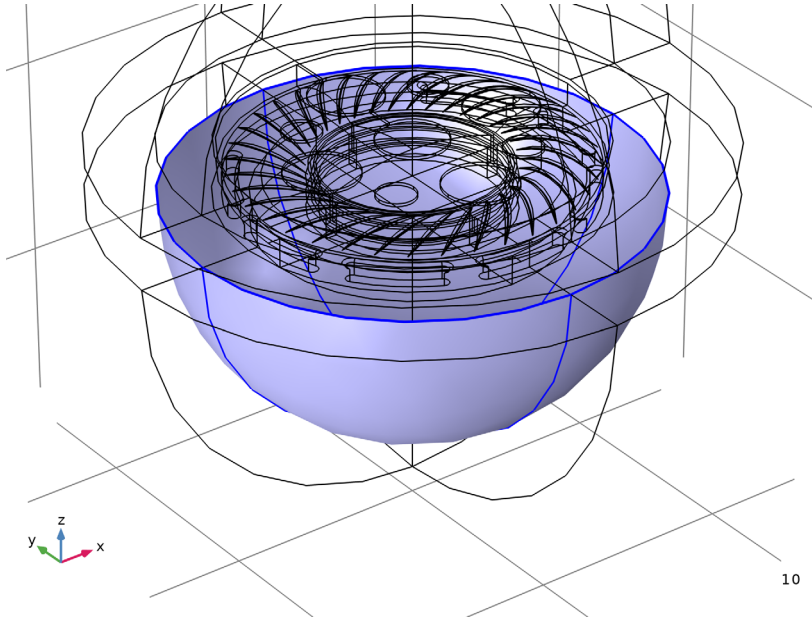
The selection should look like this:



### ADD MATERIAL

- 1 In the **Materials** toolbar, click  **Add Material** to open the **Add Material** window.
- 2 Go to the **Add Material** window.
- 3 In the tree, select **Built-in > Air**.
- 4 Click the **Add to Component** button in the window toolbar.
- 5 In the **Materials** toolbar, click  **Add Material** to close the **Add Material** window.

### MATERIALS

*PEN 38 um*

- 1 In the **Model Builder** window, under **Component 2 (comp2)** right-click **Materials** and choose **Blank Material**.
- 2 In the **Settings** window for **Material**, type `PEN 38 um` in the **Label** text field.

- 3 Locate the **Geometric Entity Selection** section. From the **Geometric entity level** list, choose **Boundary**.
- 4 From the **Selection** list, choose **Diaphragm**.
- 5 Locate the **Material Properties** section. In the **Material properties** tree, select **Basic Properties > Density**.
- 6 Click **+ Add to Material**.
- 7 In the **Material properties** tree, select **Basic Properties > Isotropic Structural Loss Factor**.
- 8 Click **+ Add to Material**.
- 9 In the **Material properties** tree, select **Basic Properties > Poisson's Ratio**.
- 10 Click **+ Add to Material**.
- 11 In the **Material properties** tree, select **Basic Properties > Young's Modulus**.
- 12 Click **+ Add to Material**.
- 13 Locate the **Material Contents** section. In the table, enter the following settings:

Property	Variable	Value	Unit	Property group
Density	rho	1360	kg/m <sup>3</sup>	Basic
Isotropic structural loss factor	eta_s	0.06	l	Basic
Poisson's ratio	nu	0.3	l	Basic
Young's modulus	E	7.20 [GPa]	Pa	Basic

As described in [Model Definition](#), it is critical to capture the correct properties of the diaphragm in order to have a representative model.

### *Coil*



- 1 Right-click **Materials** and choose **Blank Material**.
- 2 In the **Settings** window for **Material**, type **Coil** in the **Label** text field.
- 3 Locate the **Geometric Entity Selection** section. From the **Selection** list, choose **Coil**.
- 4 Locate the **Material Properties** section. In the **Material properties** tree, select **Basic Properties > Density**.
- 5 Click **+ Add to Material**.
- 6 In the **Material properties** tree, select **Basic Properties > Poisson's Ratio**.
- 7 Click **+ Add to Material**.
- 8 In the **Material properties** tree, select **Basic Properties > Young's Modulus**.
- 9 Click **+ Add to Material**.

10 Locate the **Material Contents** section. In the table, enter the following settings:

Property	Variable	Value	Unit	Property group
Density	rho	rho_coil	kg/m <sup>3</sup>	Basic
Poisson's ratio	nu	0.3		Basic
Young's modulus	E	0.5 [GPa]	Pa	Basic

As described in [Model Definition](#), the assumption that the voice coil presents isotropic properties is an oversimplification. An orthotropic material is probably a better approach to model the homogenized properties of the voice coil.

### ADD PHYSICS

- 1 In the **Home** toolbar, click  **Add Physics** to open the **Add Physics** window.
  - 2 Go to the **Add Physics** window.
  - 3 Find the **Physics interfaces in study** subsection. In the table, clear the **Solve** checkbox for **Study 1 - Axisymmetric Magnetic Analysis**.
  - 4 In the tree, select **Acoustics > Pressure Acoustics > Pressure Acoustics, Frequency Domain (acpr)**.
  - 5 Click the **Add to Component 2** button in the window toolbar.
  - 6 In the table, clear the **Solve** checkbox for **Study 1 - Axisymmetric Magnetic Analysis**.
  - 7 In the tree, select **Structural Mechanics > Solid Mechanics (solid)**.
  - 8 Click the **Add to Component 2** button in the window toolbar.
  - 9 In the table, clear the **Solve** checkbox for **Study 1 - Axisymmetric Magnetic Analysis**.
  - 10 In the tree, select **Structural Mechanics > Shell (shell)**.
  - 11 Click the **Add to Component 2** button in the window toolbar.
  - 12 In the table, clear the **Solve** checkbox for **Study 1 - Axisymmetric Magnetic Analysis**.
  - 13 In the tree, select **AC/DC > Electrical Circuit (cir)**.
  - 14 Click the **Add to Component 2** button in the window toolbar.
  - 15 In the **Home** toolbar, click  **Add Physics** to close the **Add Physics** window.
- With this step, the model has all the physics that will be used in the analysis.

### PRESSURE ACOUSTICS, FREQUENCY DOMAIN (ACPR)

- 1 In the **Settings** window for **Pressure Acoustics, Frequency Domain**, locate the **Domain Selection** section.
- 2 From the **Selection** list, choose **Air**.

### *Exterior Field Calculation 1*

- 1 In the **Physics** toolbar, click  **Boundaries** and choose **Exterior Field Calculation**.
- 2 In the **Settings** window for **Exterior Field Calculation**, locate the **Boundary Selection** section.
- 3 From the **Selection** list, choose **Exterior Field**.
- 4 Locate the **Exterior Field Calculation** section. From the **Condition in the  $z = z_0$  plane** list, choose **Symmetric/Infinite sound hard boundary**.

### *Narrow Region Acoustics 1*

- 1 In the **Physics** toolbar, click  **Domains** and choose **Narrow Region Acoustics**.
- 2 In the **Settings** window for **Narrow Region Acoustics**, locate the **Domain Selection** section.
- 3 From the **Selection** list, choose **Inner gap**.
- 4 Locate the **Duct Properties** section. From the **Duct type** list, choose **Slit**.
- 5 In the  $h$  text field, type voice\_coil\_gap1.

### *Narrow Region Acoustics 2*

- 1 In the **Physics** toolbar, click  **Domains** and choose **Narrow Region Acoustics**.
- 2 In the **Settings** window for **Narrow Region Acoustics**, locate the **Domain Selection** section.
- 3 From the **Selection** list, choose **Outer gap**.
- 4 Locate the **Duct Properties** section. From the **Duct type** list, choose **Slit**.
- 5 In the  $h$  text field, type voice\_coil\_gap2.

### *Narrow Region Acoustics 3*

- 1 In the **Physics** toolbar, click  **Domains** and choose **Narrow Region Acoustics**.
- 2 In the **Settings** window for **Narrow Region Acoustics**, locate the **Domain Selection** section.
- 3 From the **Selection** list, choose **Outer channels**.
- 4 Locate the **Duct Properties** section. From the **Duct type** list, choose **Rectangular duct**.
- 5 In the  $W$  text field, type back\_slits\_w.
- 6 In the  $H$  text field, type back\_slits\_h.

## **SOLID MECHANICS (SOLID)**

- 1 In the **Model Builder** window, under **Component 2 (comp2)** click **Solid Mechanics (solid)**.
- 2 In the **Settings** window for **Solid Mechanics**, locate the **Domain Selection** section.
- 3 From the **Selection** list, choose **Coil**.

#### Body Load - From Circuit

- 1 In the **Physics** toolbar, click  **Domains** and choose **Body Load**.
- 2 In the **Settings** window for **Body Load**, type Body Load - From Circuit in the **Label** text field.
- 3 Locate the **Domain Selection** section. From the **Selection** list, choose **Coil**.
- 4 Locate the **Force** section. From the **Load type** list, choose **Total force**.
- 5 Specify the  $\mathbf{F}_{\text{tot}}$  vector as

0	x
BL*cir.R1.i	z

This force is used to connect the electrical circuit with the other physics.

#### Body Load - Applied Force

- 1 In the **Physics** toolbar, click  **Domains** and choose **Body Load**.
- 2 In the **Settings** window for **Body Load**, type Body Load - Applied Force in the **Label** text field.
- 3 Locate the **Domain Selection** section. From the **Selection** list, choose **Coil**.
- 4 Locate the **Force** section. From the **Load type** list, choose **Total force**.
- 5 Specify the  $\mathbf{F}_{\text{tot}}$  vector as

0	x
0	y
applied_force	z

This force is used to move the diaphragm around in the Cms analysis.

#### SHELL (SHELL)

- 1 In the **Model Builder** window, under **Component 2 (comp2)** click **Shell (shell)**.
- 2 In the **Settings** window for **Shell**, locate the **Boundary Selection** section.
- 3 From the **Selection** list, choose **Diaphragm**.

#### Linear Elastic Material I

In the **Model Builder** window, under **Component 2 (comp2)** > **Shell (shell)** click **Linear Elastic Material I**.

#### Damping I

- 1 In the **Physics** toolbar, click  **Attributes** and choose **Damping**.

- 2 In the **Settings** window for **Damping**, locate the **Damping Settings** section.
- 3 From the **Damping type** list, choose **Isotropic loss factor**.

#### *Thickness and Offset 1*

- 1 In the **Model Builder** window, under **Component 2 (comp2) > Shell (shell)** click **Thickness and Offset 1**.
- 2 In the **Settings** window for **Thickness and Offset**, locate the **Thickness and Offset** section.
- 3 In the  $d_0$  text field, type `d_diag`.
- 4 From the **Position** list, choose **User defined**.
- 5 In the  $z_{\text{reloffset}}$  text field, type `0.5`.

The geometry of the diaphragm represents the bottom face of the solid, thus the model uses an offset in the shell definition.

#### *Fixed Constraint 1*

- 1 In the **Physics** toolbar, click  **Boundaries** and choose **Fixed Constraint**.
- 2 Select Boundaries 22, 23, 191, and 262 only.

### **ELECTRICAL CIRCUIT (CIR)**

In the **Model Builder** window, under **Component 2 (comp2)** click **Electrical Circuit (cir)**.

#### *Voltage Source 1 (V1)*

- 1 In the **Electrical Circuit** toolbar, click  **Voltage Source**.
- 2 In the **Settings** window for **Voltage Source**, locate the **Node Connections** section.
- 3 In the table, enter the following settings:

Label	Node names
n	0

- 4 Locate the **Device Parameters** section. In the  $v_{\text{src}}$  text field, type `V0`.

#### *Resistor 1 (R1)*

- 1 In the **Electrical Circuit** toolbar, click  **Resistor**.
- 2 In the **Settings** window for **Resistor**, locate the **Node Connections** section.
- 3 In the table, enter the following settings:

Label	Node names
p	1
n	2

- 4 Locate the **Device Parameters** section. In the  $R$  text field, type  $Z_{\text{real}}(\text{freq}) + i * Z_{\text{imag}}(\text{freq})$ .

This resistor uses the complex impedance from the electromagnetic axisymmetric model.

#### *Voltage Source 2 (V2)*

- 1 In the **Electrical Circuit** toolbar, click  **Voltage Source**.
- 2 In the **Settings** window for **Voltage Source**, locate the **Node Connections** section.
- 3 In the table, enter the following settings:

Label	Node names
p	2
n	0

- 4 Locate the **Device Parameters** section. In the  $v_{\text{src}}$  text field, type  $BL * v_0$ .  
This voltage source represents the feedback from the other physics into the electrical circuit.

### **DEFINITIONS (COMP2)**

#### *Perfectly Matched Layer 1 (pml1)*

- 1 In the **Definitions** toolbar, click  **Perfectly Matched Layer**.
- 2 In the **Settings** window for **Perfectly Matched Layer**, locate the **Domain Selection** section.
- 3 From the **Selection** list, choose **PML Top**.
- 4 Locate the **Geometry** section. From the **Type** list, choose **Spherical**.
- 5 Locate the **Scaling** section. In the **PML scaling curvature parameter** text field, type 3.  
The scaling curvature is updated to make sure that the PML absorbs the incident waves in the complete range of analysis.

### **ARTIFICIAL DOMAINS**

#### *Perfectly Matched Layer 2 (pml2)*

- 1 In the **Definitions** toolbar, click  **Perfectly Matched Layer**.
- 2 In the **Settings** window for **Perfectly Matched Layer**, locate the **Domain Selection** section.
- 3 From the **Selection** list, choose **PML Bottom**.
- 4 Locate the **Geometry** section. From the **Type** list, choose **Spherical**.

- 5 Locate the **Scaling** section. In the **PML scaling curvature parameter** text field, type 3.  
The scaling curvature is updated to make sure that the PML absorbs the incident waves in the complete range of analysis.

## MULTIPHYSICS

### *Solid–Thin Structure Connection 1 (sshc1)*

- 1 In the **Model Builder** window, under **Component 2 (comp2)** right-click **Multiphysics** and choose **Solid–Thin Structure Connection**.
- 2 In the **Settings** window for **Solid–Thin Structure Connection**, locate the **Connection Settings** section.
- 3 From the **Connection type** list, choose **Shared boundaries**.

### *Acoustic-Structure Boundary - Solid*

- 1 In the **Model Builder** window, right-click **Multiphysics** and choose **Acoustic–Structure Boundary**.
- 2 In the **Settings** window for **Acoustic–Structure Boundary**, type Acoustic-Structure Boundary - Solid in the **Label** text field.
- 3 Locate the **Boundary Selection** section. From the **Selection** list, choose **All boundaries**.

### *Acoustic-Structure Boundary - Shell*

- 1 Right-click **Multiphysics** and choose **Acoustic–Structure Boundary**.
- 2 In the **Settings** window for **Acoustic–Structure Boundary**, type Acoustic-Structure Boundary - Shell in the **Label** text field.
- 3 Locate the **Boundary Selection** section. From the **Selection** list, choose **All boundaries**.
- 4 Locate the **Coupled Interfaces** section. From the **Structure** list, choose **Shell (shell)**.

## MESH 2

This mesh is set up manually to reduce the number of elements in the model and to control the mesh density in the diaphragm. Proceed by directly adding the desired mesh component. In general, 5 to 6 second-order elements per wavelength are needed to resolve the waves. For more details, see *Meshing (Resolving the Waves)* in the *Acoustics Module User's Guide*. Here, use 6 elements per wavelength.

### *Free Tetrahedral 1*

In the **Mesh** toolbar, click  **Free Tetrahedral**.

### *Size*

- 1 In the **Model Builder** window, click **Size**.

- 2 In the **Settings** window for **Size**, locate the **Element Size** section.
- 3 Click the **Custom** button.
- 4 Locate the **Element Size Parameters** section. In the **Maximum element size** text field, type  $1\text{mm}/6$ .
- 5 In the **Minimum element size** text field, type  $1\text{[mm]}$ .
- 6 In the **Curvature factor** text field, type  $0.5$ .
- 7 Click  **Build Selected**.

#### *Mapped 1*

- 1 In the **Mesh** toolbar, click  **More Generators** and choose **Mapped**.
- 2 In the **Settings** window for **Mapped**, locate the **Boundary Selection** section.
- 3 From the **Selection** list, choose **Diaphragm mapped mesh**.

#### *Size 1*

- 1 Right-click **Mapped 1** and choose **Size**.
- 2 In the **Settings** window for **Size**, locate the **Element Size** section.
- 3 Click the **Custom** button.
- 4 Locate the **Element Size Parameters** section.
- 5 Select the **Maximum element size** checkbox. In the associated text field, type  $0.6\text{[mm]}$ .

#### *Distribution 1*

- 1 In the **Model Builder** window, right-click **Mapped 1** and choose **Distribution**.
- 2 Select Edge 467 only.
- 3 In the **Settings** window for **Distribution**, locate the **Distribution** section.
- 4 In the **Number of elements** text field, type  $2$ .

#### *Free Triangular 1*

- 1 In the **Mesh** toolbar, click  **More Generators** and choose **Free Triangular**.
- 2 In the **Settings** window for **Free Triangular**, locate the **Boundary Selection** section.
- 3 From the **Selection** list, choose **Diaphragm triangular mesh**.

#### *Size 1*

- 1 Right-click **Free Triangular 1** and choose **Size**.
- 2 In the **Settings** window for **Size**, locate the **Element Size** section.
- 3 Click the **Custom** button.
- 4 Locate the **Element Size Parameters** section.

- 5 Select the **Maximum element size** checkbox. In the associated text field, type 0.6[mm].
- 6 Select the **Minimum element size** checkbox. In the associated text field, type 0.2[mm].

#### *Swept 1*

- 1 In the **Mesh** toolbar, click  **Swept**.
- 2 In the **Settings** window for **Swept**, locate the **Domain Selection** section.
- 3 From the **Geometric entity level** list, choose **Domain**.
- 4 From the **Selection** list, choose **Coil**.

#### *Distribution 1*

- 1 Right-click **Swept 1** and choose **Distribution**.
- 2 In the **Settings** window for **Distribution**, locate the **Distribution** section.
- 3 In the **Number of elements** text field, type 2.

#### *Swept 2*

- 1 In the **Mesh** toolbar, click  **Swept**.
- 2 In the **Settings** window for **Swept**, locate the **Domain Selection** section.
- 3 From the **Geometric entity level** list, choose **Domain**.
- 4 From the **Selection** list, choose **Inner gap**.

#### *Distribution 1*

- 1 Right-click **Swept 2** and choose **Distribution**.
- 2 In the **Settings** window for **Distribution**, locate the **Distribution** section.
- 3 In the **Number of elements** text field, type 2.

#### *Swept 3*

- 1 In the **Mesh** toolbar, click  **Swept**.
- 2 In the **Settings** window for **Swept**, locate the **Domain Selection** section.
- 3 From the **Geometric entity level** list, choose **Domain**.
- 4 From the **Selection** list, choose **Outer gap**.

#### *Distribution 1*

- 1 Right-click **Swept 3** and choose **Distribution**.
- 2 In the **Settings** window for **Distribution**, locate the **Distribution** section.
- 3 In the **Number of elements** text field, type 2.

### *Free Tetrahedral 1*

- 1 In the **Model Builder** window, under **Component 2 (comp2) > Mesh 2** click **Free Tetrahedral 1**.
- 2 In the **Settings** window for **Free Tetrahedral**, locate the **Domain Selection** section.
- 3 From the **Geometric entity level** list, choose **Domain**.
- 4 Select Domains 3–9, 16, 17, and 22–24 only.
- 5 Click  **Build All**.

### *Swept 4*

In the **Mesh** toolbar, click  **Swept**.

### *Distribution 1*

- 1 Right-click **Swept 4** and choose **Distribution**.
- 2 In the **Settings** window for **Distribution**, locate the **Distribution** section.
- 3 In the **Number of elements** text field, type 8.
- 4 Click  **Build Selected**.

### *Boundary Layers 1*

- 1 In the **Mesh** toolbar, click  **Boundary Layers**.
- 2 In the **Settings** window for **Boundary Layers**, locate the **Geometric Entity Selection** section.
- 3 From the **Geometric entity level** list, choose **Domain**.
- 4 Select Domains 3 and 4 only.
- 5 Click to expand the **Transition** section. Clear the **Smooth transition to interior mesh** checkbox.

### *Boundary Layer Properties*

- 1 In the **Model Builder** window, click **Boundary Layer Properties**.
- 2 Select Boundaries 11, 12, 15, 16, 187, 189, 220, and 227 only.
- 3 In the **Settings** window for **Boundary Layer Properties**, locate the **Layers** section.
- 4 In the **Number of layers** text field, type 1.
- 5 Click  **Build Selected**.

### **ADD STUDY**

- 1 In the **Home** toolbar, click  **Add Study** to open the **Add Study** window.
- 2 Go to the **Add Study** window.

- 3 Find the **Physics interfaces in study** subsection. In the table, clear the **Solve** checkboxes for **Magnetic Fields (mf)**, **Pressure Acoustics, Frequency Domain (acpr)**, and **Electrical Circuit (cir)**.
- 4 Find the **Multiphysics couplings in study** subsection. In the table, clear the **Solve** checkboxes for **Acoustic-Structure Boundary - Solid (asb1)** and **Acoustic-Structure Boundary - Shell (asb2)**.
- 5 Find the **Studies** subsection. In the **Select Study** tree, select **General Studies > Stationary**.
- 6 Click the **Add Study** button in the window toolbar.
- 7 In the **Home** toolbar, click  **Add Study** to close the **Add Study** window.

## STUDY 2 - CMS EXTRACTION

- 1 In the **Settings** window for **Study**, type Study 2 - CMS Extraction in the **Label** text field.

This step applies a varying force on the voice coil and measures the displacement to obtain the nonlinear Cms curve. Only the **Solid Mechanics** and the **Shell interface** will be considered in this step as the other physics do not modify the Cms curve.

### Step 1: Stationary

- 1 In the **Model Builder** window, under **Study 2 - CMS Extraction** click **Step 1: Stationary**.
- 2 In the **Settings** window for **Stationary**, locate the **Study Settings** section.
- 3 Select the **Include geometric nonlinearity** checkbox.
- 4 Click to expand the **Mesh Selection** section. In the table, enter the following settings:

Component	Mesh
Component 1	No mesh

- 5 Click to expand the **Study Extensions** section. Select the **Auxiliary sweep** checkbox.
- 6 Click **+ Add**.
- 7 In the table, enter the following settings:

Parameter name	Parameter value list	Parameter unit
applied_force (Applied force)		N

- 8 In the table, click to select the cell at row number 1 and column number 3.

9 In the table, enter the following settings:

Parameter name	Parameter value list	Parameter unit
applied_force (Applied force)	range ( -1 , 0 . 1 , 1 )	N

10 In the table, click to select the cell at row number 1 and column number 3.

11 Right-click **Study 2 - CMS Extraction > Step 1: Stationary** and choose **Get Initial Value for Step**.

12 Locate the **Study Settings** section. From the **Tolerance** list, choose **User controlled**.

13 In the **Relative tolerance** text field, type 1e-5.

The tolerance is manually reduced to assure that numerical noise will not affect the Cms curve obtained.

14 In the **Study** toolbar, click  **Compute**.

## RESULTS

### *Evaluation Group - Force Displacement Curve*

1 In the **Results** toolbar, click  **Evaluation Group**.

2 In the **Settings** window for **Evaluation Group**, type Evaluation Group - Force Displacement Curve in the **Label** text field.

3 Locate the **Data** section. From the **Dataset** list, choose **Study 2 - CMS Extraction/ Solution 3 (4) (sol3)**.

4 Click to expand the **Format** section. From the **Include parameters** list, choose **Off**.

### *Global Evaluation 1*

1 Right-click **Evaluation Group - Force Displacement Curve** and choose **Global Evaluation**.

2 In the **Settings** window for **Global Evaluation**, locate the **Expressions** section.

3 In the table, enter the following settings:

Expression	Unit	Description
ave_coil(w)		Average coil displacement
applied_force	N	Applied force

4 In the **Evaluation Group - Force Displacement Curve** toolbar, click  **Evaluate**.

Through this evaluation group, the force/displacement characteristics of the diaphragm are exported in a table that will be used in further steps.

## GLOBAL DEFINITIONS

*Force displacement from COMSOL*

- 1** In the **Home** toolbar, click  **Functions** and choose **Global > Interpolation**.
- 2** In the **Settings** window for **Interpolation**, type Force displacement from COMSOL in the **Label** text field.
- 3** Locate the **Definition** section. From the **Data source** list, choose **Result table**.
- 4** From the **Table from** list, choose **Evaluation Group - Force Displacement Curve**.
- 5** Locate the **Data Column Settings** section. In the table, click to select the cell at row number 1 and column number 1.
- 6** In the **Unit** text field, type mm.
- 7** In the table, click to select the cell at row number 2 and column number 1.
- 8** In the **Name** text field, type Force.
- 9** In the **Unit** text field, type N.
- 10** Locate the **Interpolation and Extrapolation** section. From the **Interpolation** list, choose **Piecewise cubic**.
- 11** From the **Extrapolation** list, choose **Nearest function**.

12 Click  **Plot**.

This function is declared to facilitate the derivation of the force-displacement curve, the stiffness. The plot should look like this:

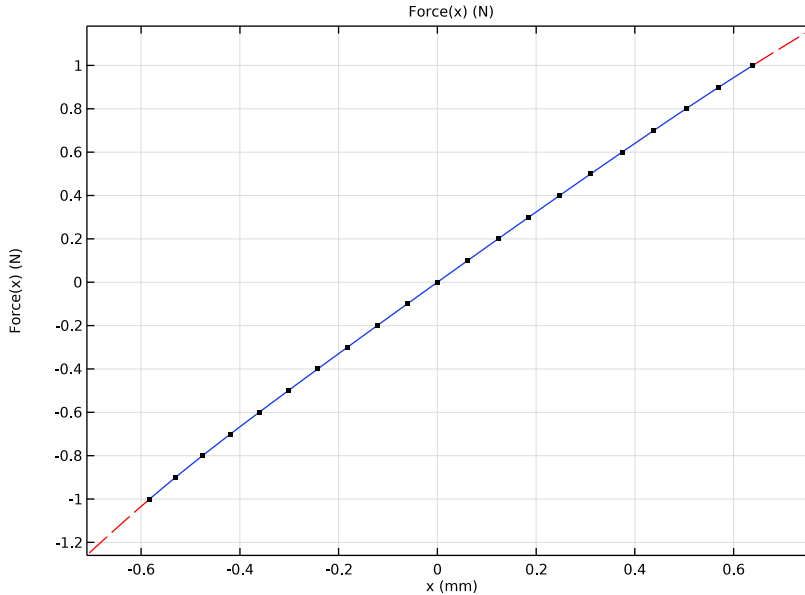

## STUDY 2 - CMS EXTRACTION

1 In the **Study** toolbar, click  **Update Solution**.

With the study update, the function previously declared will be available in the results of the CMS Extraction study.

## RESULTS

### Grid ID 1

1 In the **Results** toolbar, click  **More Datasets** and choose **Grid** > **Grid ID**.

2 In the **Settings** window for **Grid ID**, locate the **Data** section.

3 From the **Dataset** list, choose **Study 2 - CMS Extraction/Solution 3 (4) (sol3)**.

4 Locate the **Parameter Bounds** section. In the **Minimum** text field, type -0.5.

5 In the **Maximum** text field, type 0.5.

### CMS vs. Displacement

1 In the **Results** toolbar, click  **ID Plot Group**.

- 2 In the **Settings** window for **ID Plot Group**, type CMS vs. Displacement in the **Label** text field.
- 3 Locate the **Data** section. From the **Dataset** list, choose **Grid ID 1**.
- 4 From the **Parameter selection (applied\_force)** list, choose **Last**.
- 5 Locate the **Title** section. From the **Title type** list, choose **Manual**.
- 6 In the **Title** text area, type CMS (mm/N) vs. Displacement (mm).
- 7 Locate the **Plot Settings** section.
- 8 Select the **x-axis label** checkbox. In the associated text field, type Voice coil offset (mm).
- 9 Locate the **Axis** section. Select the **Manual axis limits** checkbox.
- 10 In the **x minimum** text field, type -0.5.
- 11 In the **x maximum** text field, type 0.5.
- 12 In the **y minimum** text field, type 0.
- 13 In the **y maximum** text field, type 0.7.
- 14 Locate the **Legend** section. From the **Position** list, choose **Lower left**.

*CMS curve from test*

- 1 Right-click **CMS vs. Displacement** and choose **Line Graph**.
- 2 In the **Settings** window for **Line Graph**, type CMS curve from test in the **Label** text field.
- 3 Locate the **y-Axis Data** section. In the **Expression** text field, type CMS\_Test(x).
- 4 In the **Unit** field, type mm/N.
- 5 Locate the **Title** section. From the **Title type** list, choose **None**.
- 6 Locate the **x-Axis Data** section. From the **Parameter** list, choose **Expression**.
- 7 In the **Expression** text field, type x.
- 8 Locate the **Coloring and Style** section. From the **Color** list, choose **Blue**.
- 9 Locate the **Legends** section. Select the **Show legends** checkbox.
- 10 Find the **Include** subsection. Select the **Label** checkbox.
- 11 Clear the **Solution** checkbox.

*CMS curve from test (inverted)*

- 1 Right-click **CMS curve from test** and choose **Duplicate**.
- 2 In the **Settings** window for **Line Graph**, type CMS curve from test (inverted) in the **Label** text field.

- 3 Locate the **x-Axis Data** section. In the **Expression** text field, type  $-x$ .
- 4 Locate the **Coloring and Style** section. Find the **Line style** subsection. From the **Line** list, choose **Dotted**.
- 5 Locate the **Legends** section. Clear the **Show legends** checkbox.

#### *CMS curve from COMSOL*

- 1 In the **Model Builder** window, right-click **CMS vs. Displacement** and choose **Line Graph**.
- 2 In the **Settings** window for **Line Graph**, type CMS curve from COMSOL in the **Label** text field.
- 3 Locate the **y-Axis Data** section. In the **Expression** text field, type  $1 / (d(\text{Force}(x), x))$ .
- 4 In the **Unit** field, type mm/N.
- 5 Locate the **Title** section. From the **Title type** list, choose **None**.
- 6 Locate the **x-Axis Data** section. From the **Parameter** list, choose **Expression**.
- 7 In the **Expression** text field, type  $x$ .
- 8 Locate the **Coloring and Style** section. From the **Color** list, choose **Red**.
- 9 Locate the **Legends** section. Select the **Show legends** checkbox.
- 10 Find the **Include** subsection. Select the **Label** checkbox.
- 11 Clear the **Solution** checkbox.

#### *CMS curve from COMSOL (inverted)*

- 1 Right-click **CMS curve from COMSOL** and choose **Duplicate**.
- 2 In the **Settings** window for **Line Graph**, type CMS curve from COMSOL (inverted) in the **Label** text field.
- 3 Locate the **x-Axis Data** section. In the **Expression** text field, type  $-x$ .
- 4 Locate the **Coloring and Style** section. Find the **Line style** subsection. From the **Line** list, choose **Dotted**.
- 5 Locate the **Legends** section. Clear the **Show legends** checkbox.
- 6 In the **CMS vs. Displacement** toolbar, click  **Plot**.  
The plot should look like [Figure 7](#).

#### *CMS vs. Displacement, Stress (shell), Stress (solid)*

- 1 In the **Model Builder** window, under **Results**, Ctrl-click to select **Stress (solid)**, **Stress (shell)**, and **CMS vs. Displacement**.
- 2 Right-click and choose **Group**.

### Postprocessing - CMS Analysis

1 In the **Settings** window for **Group**, type Postprocessing - CMS Analysis in the **Label** text field.

Grouping the plots facilitates the navigation through the different output in the file.

### ADD STUDY

1 In the **Home** toolbar, click  **Add Study** to open the **Add Study** window.

2 Go to the **Add Study** window.

3 Find the **Physics interfaces in study** subsection. In the table, clear the **Solve** checkbox for **Magnetic Fields (mf)**.

4 Find the **Studies** subsection. In the **Select Study** tree, select **General Studies > Frequency Domain**.

5 Click the **Add Study** button in the window toolbar.

6 In the **Home** toolbar, click  **Add Study** to close the **Add Study** window.

The magnetic study is turned off as its contribution is included in the electrical circuit.

### STUDY 3 - ACOUSTIC ANALYSIS

In the **Settings** window for **Study**, type Study 3 - Acoustic Analysis in the **Label** text field.

#### Step 1: Frequency Domain

1 In the **Model Builder** window, under **Study 3 - Acoustic Analysis** click **Step 1: Frequency Domain**.

2 In the **Settings** window for **Frequency Domain**, locate the **Study Settings** section.

3 Click  **Range**.

4 In the **Range** dialog, choose **ISO preferred frequencies** from the **Entry method** list.

5 In the **Start frequency** text field, type 100.

6 In the **Stop frequency** text field, type 20000.

7 From the **Interval** list, choose **1/12 octave**.

8 Click **Replace**.

9 In the **Settings** window for **Frequency Domain**, locate the **Physics and Variables Selection** section.

10 Select the **Modify model configuration for study step** checkbox.

11 In the tree, select **Component 2 (comp2) > Solid Mechanics (solid) > Body Load - Applied Force**.

12 Right-click and choose **Disable**.

13 Click to expand the **Mesh Selection** section. In the table, enter the following settings:

Component	Mesh
Component 1	No mesh

14 Right-click **Study 3 - Acoustic Analysis > Step 1: Frequency Domain** and choose **Get Initial Value for Step**.

#### *Solution 4 (sol4)*

1 In the **Model Builder** window, under **Study 3 - Acoustic Analysis > Solver Configurations > Solution 4 (sol4)** right-click **Stationary Solver 1** and choose **Fully Coupled**.

2 Right-click **Study 3 - Acoustic Analysis > Solver Configurations > Solution 4 (sol4) > Stationary Solver 1 > Suggested Iterative Solver (GMRES with Direct Precond.) (asb1\_sshc1\_asb2)** and choose **Enable**.

3 In the **Model Builder** window, expand the **Study 3 - Acoustic Analysis > Solver Configurations > Solution 4 (sol4) > Stationary Solver 1 > Suggested Iterative Solver (GMRES with Direct Precond.) (asb1\_sshc1\_asb2)** node, then click **Direct Preconditioner 2**.

4 In the **Settings** window for **Direct Preconditioner**, click to expand the **Hybridization** section.

5 Under **Preconditioner variables**, click **+ Add**.

6 In the **Add** dialog, select **Currents (comp2.currents)** in the **Preconditioner variables** list.

7 Click **OK**.

8 In the **Settings** window for **Direct Preconditioner**, click **= Run**.

## **RESULTS**

### *Thermoviscous results*

1 In the **Results** toolbar, click  **Table**.

2 In the **Settings** window for **Table**, locate the **Data** section.

3 Click  **Import**.

4 Browse to the model's Application Libraries folder and double-click the file `ow_microspeaker_spl_39mm_thermoviscous.txt`.

5 In the **Label** text field, type `Thermoviscous results`.

As described in [Model Definition](#), this table contains the results of a thermoviscous model that will be compared to the tutorial results and the measurements.

#### *Outgoing Acoustic Energy*

- 1 In the **Results** toolbar, click  **ID Plot Group**.
- 2 In the **Settings** window for **ID Plot Group**, type `Outgoing Acoustic Energy` in the **Label** text field.
- 3 Locate the **Data** section. From the **Dataset** list, choose **Study 3 - Acoustic Analysis/ Solution 4 (6) (sol4)**.
- 4 Locate the **Plot Settings** section.
- 5 Select the **x-axis label** checkbox. In the associated text field, type `freq (Hz)`.
- 6 Select the **y-axis label** checkbox. In the associated text field, type `Energy (W)`.
- 7 Locate the **Axis** section. Select the **x-axis log scale** checkbox.
- 8 Select the **y-axis log scale** checkbox.
- 9 Locate the **Legend** section. From the **Position** list, choose **Lower middle**.

#### *Global I*

- 1 Right-click **Outgoing Acoustic Energy** and choose **Global**.
- 2 In the **Settings** window for **Global**, locate the **y-Axis Data** section.
- 3 In the table, enter the following settings:

<b>Expression</b>	<b>Unit</b>	<b>Description</b>
<code>int_PML_Top(I_int)</code>	W	PML Top Integral
<code>int_PML_Bottom(I_int)</code>	W	PML Bottom Integral

4 In the **Outgoing Acoustic Energy** toolbar, click  **Plot**.

The plot shows the acoustic energy traveling to the PML. This plot shows positive values for the entire frequency range, as expected for a working PML.

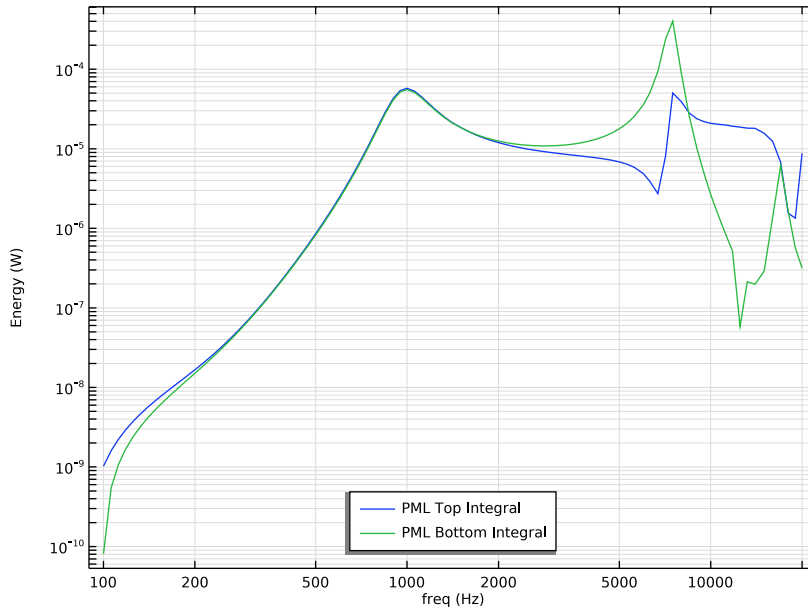

#### *Speaker Sensitivity and Phase at 39 mm*

- 1 In the **Results** toolbar, click  **ID Plot Group**.
- 2 In the **Settings** window for **ID Plot Group**, type **Speaker Sensitivity and Phase at 39 mm** in the **Label** text field.
- 3 Locate the **Data** section. From the **Dataset** list, choose **Study 3 - Acoustic Analysis/ Solution 4 (6) (sol4)**.
- 4 Locate the **Title** section. From the **Title type** list, choose **Manual**.
- 5 In the **Title** text area, type **SPL at 39 mm (dB)**.
- 6 Locate the **Plot Settings** section.
- 7 Select the **x-axis label** checkbox. In the associated text field, type **freq (Hz)**.
- 8 Select the **y-axis label** checkbox. In the associated text field, type **SPL (dB)**.

#### *Global 1*

- 1 Right-click **Speaker Sensitivity and Phase at 39 mm** and choose **Global**.
- 2 In the **Settings** window for **Global**, locate the **y-Axis Data** section.

3 In the table, enter the following settings:

Expression	Unit	Description
SPL_Test(freq)	dB	Measured SPL at 39 mm

4 Click to expand the **Coloring and Style** section. From the **Width** list, choose **3**.

*Speaker Sensitivity and Phase at 39 mm*

In the **Model Builder** window, click **Speaker Sensitivity and Phase at 39 mm**.

*Octave Band 1*

1 In the **Speaker Sensitivity and Phase at 39 mm** toolbar, click  **More Plots** and choose **Octave Band**.

2 In the **Settings** window for **Octave Band**, locate the **Selection** section.

3 From the **Geometric entity level** list, choose **Global**.

4 Locate the **y-Axis Data** section. In the **Expression** text field, type `pext(0,0,39[mm])`.

5 Locate the **Plot** section. From the **Quantity** list, choose **Continuous power spectral density**.

6 Click to expand the **Legends** section. Select the **Show legends** checkbox.

7 From the **Legends** list, choose **Manual**.

8 In the table, enter the following settings:

Legends
COMSOL results

*Table Graph 1*

1 Right-click **Speaker Sensitivity and Phase at 39 mm** and choose **Table Graph**.

2 In the **Speaker Sensitivity and Phase at 39 mm** toolbar, click  **Plot**.

3 In the **Model Builder** window, click **Table Graph 1**.

4 In the **Settings** window for **Table Graph**, click to expand the **Legends** section.

5 Select the **Show legends** checkbox.

6 From the **Legends** list, choose **Manual**.

7 In the table, enter the following settings:

Legends
COMSOL results with thermoviscous

### Speaker Sensitivity and Phase at 39 mm

In the **Speaker Sensitivity and Phase at 39 mm** toolbar, click  **Global**.

#### Global 2

- 1 In the **Settings** window for **Global**, locate the **y-Axis Data** section.
- 2 In the table, enter the following settings:

Expression	Unit	Description
$\arg(\text{pext}(0,0,39[\text{mm}] ))$	deg	Phase

- 3 Select the **Unwrap phase** checkbox.

### Speaker Sensitivity and Phase at 39 mm

- 1 In the **Model Builder** window, click **Speaker Sensitivity and Phase at 39 mm**.
- 2 In the **Settings** window for **ID Plot Group**, locate the **Plot Settings** section.
- 3 Select the **Two y-axes** checkbox.
- 4 In the table, select the **Plot on secondary y-axis** checkbox for **Global 2**.
- 5 Select the **Secondary y-axis label** checkbox.
- 6 Locate the **Axis** section. Select the **Manual axis limits** checkbox.
- 7 In the **x minimum** text field, type 100.
- 8 In the **x maximum** text field, type 20000.
- 9 In the **y minimum** text field, type 50.
- 10 In the **y maximum** text field, type 100.
- 11 Select the **x-axis log scale** checkbox.
- 12 In the **Secondary y minimum** text field, type -900.
- 13 In the **Secondary y maximum** text field, type 200.
- 14 Locate the **Legend** section. From the **Position** list, choose **Lower middle**.
- 15 In the **Speaker Sensitivity and Phase at 39 mm** toolbar, click  **Plot**.

The plot should look like the one in [Figure 10](#).

### Total Impedance

- 1 In the **Results** toolbar, click  **ID Plot Group**.
- 2 In the **Settings** window for **ID Plot Group**, type Total Impedance in the **Label** text field.
- 3 Locate the **Data** section. From the **Dataset** list, choose **Study 3 - Acoustic Analysis/ Solution 4 (6) (sol4)**.
- 4 Locate the **Plot Settings** section.

- 5 Select the **x-axis label** checkbox. In the associated text field, type `freq (Hz)`.
- 6 Select the **y-axis label** checkbox. In the associated text field, type `Impedance (ohm)`.
- 7 Locate the **Axis** section. Select the **x-axis log scale** checkbox.

#### Global I

- 1 Right-click **Total Impedance** and choose **Global**.
- 2 In the **Settings** window for **Global**, locate the **y-Axis Data** section.
- 3 In the table, enter the following settings:

Expression	Unit	Description
<code>Z_Test(freq)</code>	$\Omega$	Measured Impedance
<code>abs(-cir.V1.v/cir.V1.i)</code>	$\Omega$	COMSOL results

- 4 In the **Total Impedance** toolbar, click  **Plot**.

The plot should look like the one in [Figure 8](#).

*Acoustic Pressure (acpr), Acoustic Pressure, Isosurfaces (acpr), Exterior-Field Pressure (acpr), Exterior-Field Sound Pressure Level (acpr), Exterior-Field Sound Pressure Level xy-plane (acpr), Outgoing Acoustic Energy, Sound Pressure Level (acpr), Speaker Sensitivity and Phase at 39 mm, Stress (shell) I, Stress (solid) I, Total Impedance*

- 1 In the **Model Builder** window, under **Results**, Ctrl-click to select **Acoustic Pressure (acpr)**, **Sound Pressure Level (acpr)**, **Acoustic Pressure, Isosurfaces (acpr)**, **Exterior-Field Sound Pressure Level (acpr)**, **Exterior-Field Pressure (acpr)**, **Exterior-Field Sound Pressure Level xy-plane (acpr)**, **Stress (solid) I**, **Stress (shell) I**, **Outgoing Acoustic Energy**, **Speaker Sensitivity and Phase at 39 mm**, and **Total Impedance**.
- 2 Right-click and choose **Group**.

#### Postprocessing - Acoustic Analysis

- 1 In the **Settings** window for **Group**, type `Postprocessing - Acoustic Analysis` in the **Label** text field.

The acoustics results are now under a single group, which simplifies the navigation between results of different studies.

Now, proceed to generate a plot showing the displacement of the diaphragm and the voice coil, similar to the plots in [Figure 9](#).

#### Thumbnail

- 1 In the **Results** toolbar, click  **3D Plot Group**.
- 2 In the **Settings** window for **3D Plot Group**, type `Thumbnail` in the **Label** text field.

- 3 Locate the **Data** section. From the **Dataset** list, choose **Study 3 - Acoustic Analysis/ Solution 4 (6) (sol4)**.
- 4 From the **Parameter value (freq (Hz))** list, choose **7500**.
- 5 Locate the **Color Legend** section. Select the **Show units** checkbox.
- 6 Click to expand the **Title** section. From the **Title type** list, choose **Manual**.
- 7 In the **Title** text area, type Surface: Displacement magnitude (mm).
- 8 In the **Parameter indicator** text field, type `freq = eval(acpr.freq)` Hz.
- 9 Locate the **Plot Settings** section. Clear the **Plot dataset edges** checkbox.

#### *Shell displacement*

- 1 Right-click **Thumbnail** and choose **Surface**.
- 2 In the **Settings** window for **Surface**, type Shell displacement in the **Label** text field.
- 3 Locate the **Expression** section. In the **Expression** text field, type `shell.disp`.
- 4 Locate the **Coloring and Style** section. From the **Scale** list, choose **Linear**.
- 5 From the **Color table** list, choose **SpectrumLight**.

#### *Deformation 1*

- 1 Right-click **Shell displacement** and choose **Deformation**.
- 2 In the **Settings** window for **Deformation**, locate the **Expression** section.
- 3 In the **x-component** text field, type `u2`.
- 4 In the **y-component** text field, type `v2`.
- 5 In the **z-component** text field, type `w2`.

#### *Filter 1*

- 1 In the **Model Builder** window, right-click **Shell displacement** and choose **Filter**.
- 2 In the **Settings** window for **Filter**, locate the **Element Selection** section.
- 3 In the **Logical expression for inclusion** text field, type `x>0`.

#### *Line 1*

- 1 In the **Model Builder** window, right-click **Thumbnail** and choose **Line**.
- 2 In the **Settings** window for **Line**, locate the **Expression** section.
- 3 In the **Expression** text field, type `1`.
- 4 Locate the **Coloring and Style** section. From the **Coloring** list, choose **Uniform**.
- 5 From the **Color** list, choose **Black**.
- 6 Click to expand the **Inherit Style** section. From the **Plot** list, choose **Shell displacement**.

- 7 Clear the **Color** checkbox.
- 8 Clear the **Color and data range** checkbox.
- 9 Clear the **Tube radius scale factor** checkbox.

#### *Deformation 1*

- 1 Right-click **Line 1** and choose **Deformation**.
- 2 In the **Settings** window for **Deformation**, locate the **Expression** section.
- 3 In the **x-component** text field, type  $u2$ .
- 4 In the **y-component** text field, type  $v2$ .
- 5 In the **z-component** text field, type  $w2$ .

#### *Filter 1*

- 1 In the **Model Builder** window, right-click **Line 1** and choose **Filter**.
- 2 In the **Settings** window for **Filter**, locate the **Element Selection** section.
- 3 In the **Logical expression for inclusion** text field, type  $x > 0$ .

#### *Solid Displacement*

- 1 In the **Model Builder** window, right-click **Thumbnail** and choose **Surface**.
- 2 In the **Settings** window for **Surface**, type **Solid Displacement** in the **Label** text field.
- 3 Locate the **Expression** section. In the **Expression** text field, type  $\text{solid.disp}$ .
- 4 Click to expand the **Inherit Style** section. From the **Plot** list, choose **Shell displacement**.

#### *Deformation 1*

Right-click **Solid Displacement** and choose **Deformation**.

#### *Filter 1*

- 1 In the **Model Builder** window, right-click **Solid Displacement** and choose **Filter**.
- 2 In the **Settings** window for **Filter**, locate the **Element Selection** section.
- 3 In the **Logical expression for inclusion** text field, type  $x > 0$ .

#### *Line 2*

In the **Model Builder** window, under **Results > Thumbnail** right-click **Line 1** and choose **Duplicate**.

#### *Deformation 1*

- 1 In the **Model Builder** window, expand the **Line 2** node, then click **Deformation 1**.
- 2 In the **Settings** window for **Deformation**, locate the **Expression** section.
- 3 In the **x-component** text field, type  $u$ .

- 4 In the **y-component** text field, type *v*.
- 5 In the **z-component** text field, type *w*.

#### *Solid Displacement Section*

- 1 In the **Model Builder** window, right-click **Thumbnail** and choose **Slice**.
- 2 In the **Settings** window for **Slice**, type **Solid Displacement Section** in the **Label** text field.
- 3 Locate the **Expression** section. In the **Expression** text field, type `solid.disp`.
- 4 Locate the **Plane Data** section. From the **Entry method** list, choose **Coordinates**.
- 5 Click to expand the **Inherit Style** section. From the **Plot** list, choose **Shell displacement**.

#### *Deformation I*

- 1 Right-click **Solid Displacement Section** and choose **Deformation**.
- 2 In the **Thumbnail** toolbar, click  **Plot**.

The plot should look like [Figure 9](#). You can cycle through the phase of the solution by updating the phase in the dataset options.