



Model created in COMSOL Multiphysics 6.4

MEMS Microphone with Slip Wall

Introduction

The development in the area of MEMS devices and microphones is fast, and MEMS microphones are becoming a standard part of various products from laptops to earbuds. This tutorial demonstrates how to set up a model of a MEMS microphone consisting of a micro-perforated plate (MPP) and a vibrating membrane, see [Figure 1](#). The design with an MPP and a diaphragm is used in [Ref. 1](#), the geometry in this model is inspired by [Ref. 1](#) but is simplified and uses different parameters.

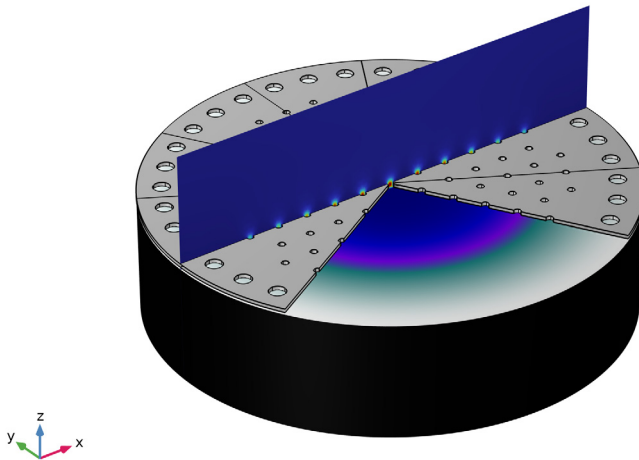

Figure 1: MEMS microphone consisting of a micro-perforated plate (MPP) and a vibrating membrane. The harmonic displacement of the membrane is shown together with the acoustic velocity through the MPP.

The development in manufacturing processes allows to make MEMS devices with smaller length scales. The small length scales lead to high Knudsen numbers and therefore a domain where noncontinuum effects can become important. This model shows how to include a slip velocity boundary condition and thereby increase the range of Knudsen numbers where the finite element model is valid. The slip velocity boundary condition is typically used for Knudsen numbers in the range from 0.001 to 0.01.

Note, the perforation ratio of the MPP in the model is quite low, this is to reduce the number of holes and thus the size of the numerical model.

Model Definition

The MEMS microphone consists of an MPP and a vibrating diaphragm, and a closed backing volume. The MEMS microphone is cylindrical with the holes in the MPP placed in a hexagonal lattice structure. The symmetry allows for modeling a 30-degree section of the cylinder.

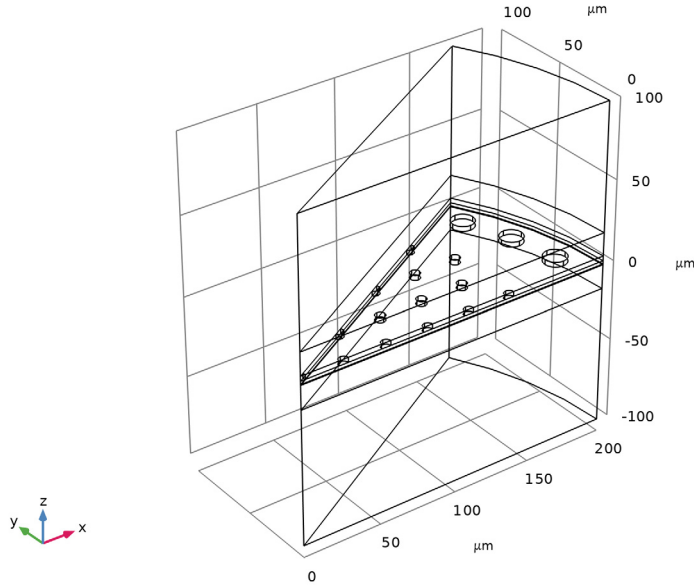

Figure 2: Geometry of the MEMS microphone. A 30-degree section is modeled with symmetry planes.

The MPP consists of holes with $3 \mu\text{m}$ radius in a hexagonal structure and vent holes with $7 \mu\text{m}$ radius at the edge of the plate. The MPP has a thickness of $3 \mu\text{m}$, and the diaphragm a thickness of $0.5 \mu\text{m}$. The distance between the MPP and diaphragm is $2 \mu\text{m}$. Below the diaphragm is a closed backing volume modeled with Thermoviscous Acoustics, and the domain above the MPP; the holes in the MPP; and the gap between the MPP and diaphragm are modeled with Thermoviscous Acoustics.

The **Slip Wall** boundary condition is applied to the surface of the diaphragm and MPP in the Thermoviscous Acoustics domain. When setting a **Slip Wall** boundary condition the tangential velocity at the wall will depend on the stress in the fluid at the boundary, thus creating a discontinuity between the velocity of the solid and the fluid.

The diaphragm is prestressed by an electric field which gives a stationary deformation of the diaphragm. The diaphragm is connected to ground while a **Terminal** on the MPP is connected to an **Electrical Circuit**. The Electrical Circuit consists of a **Resistor** and a **Voltage Source** of 1V. This results in an electric field between the MPP and diaphragm and a deformation which is modeled with **Moving Mesh**.

In the frequency domain study, a pressure is applied on the surface above the MPP in the **Thermoviscous Acoustics** domain. The diaphragm will vibrate due to the pressure field, and this will cause a varying electrical signal due to the variations in the distance between the MPP and diaphragm.

To model the correct electric response of the MEMS microphone it is important to model the correct damping in the flow through the holes in the MPP and in the squeezing flow between the MPP and the diaphragm. For small length scales it can be necessary to include the noncontinuum effects with the **Slip Wall** boundary condition.

Results and Discussion

The resulting acoustic pressure in all domains is shown in [Figure 3](#).

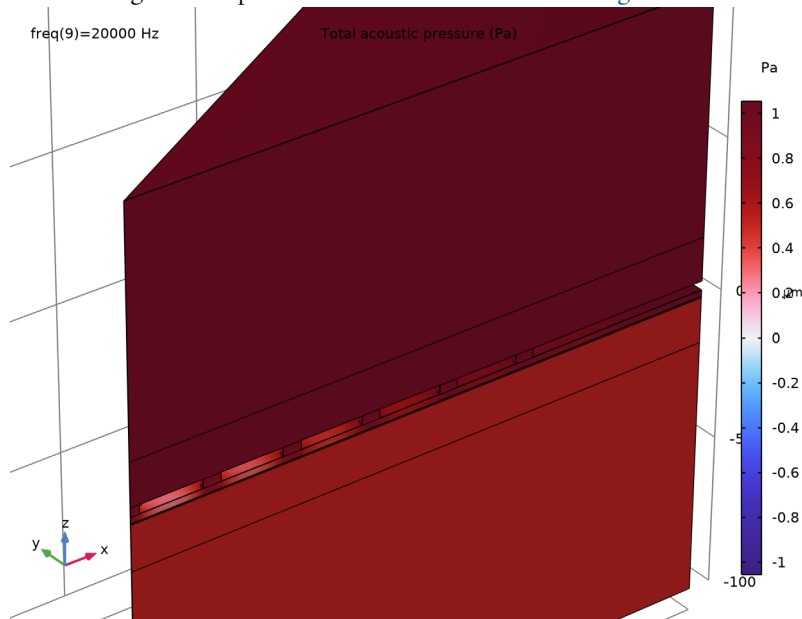

Figure 3: Acoustic pressure at 20 kHz.

The acoustic velocity is shown in [Figure 4](#). Note the high velocities both through the holes in the MPP and in the squeezing flow between the MPP and the diaphragm. These areas are the sources for the viscous damping in the system.

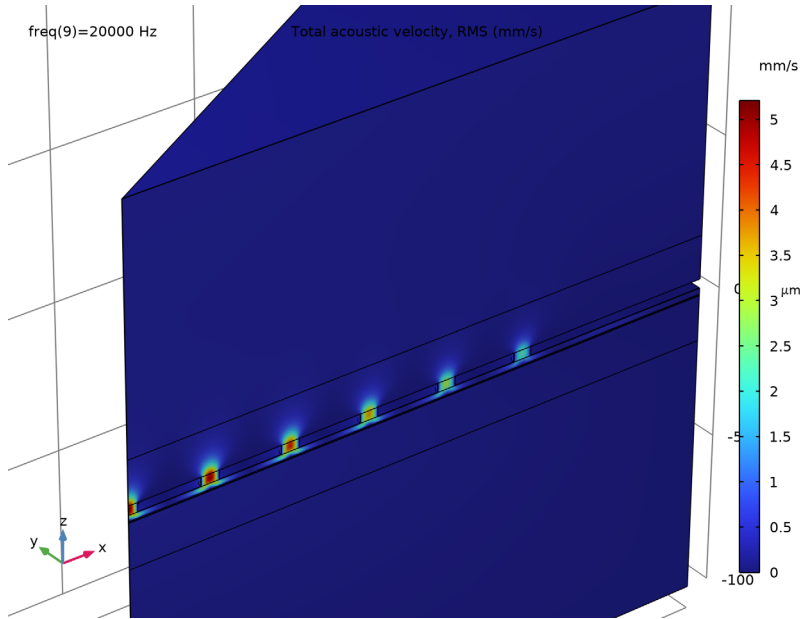

Figure 4: Acoustic pressure.

[Figure 5](#) shows the frequency response of the MEMS microphone from 200 Hz to 20 kHz. At the lower frequencies there is roll-off due to the coupling to the electrical circuit (modifying the resistance the electrical circuit changes this behavior). At the high frequencies the response drops off. Because of the small length scale of the model, the mechanical resonances are located at higher frequencies and thus the spectrum is more or less flat in the audio range.

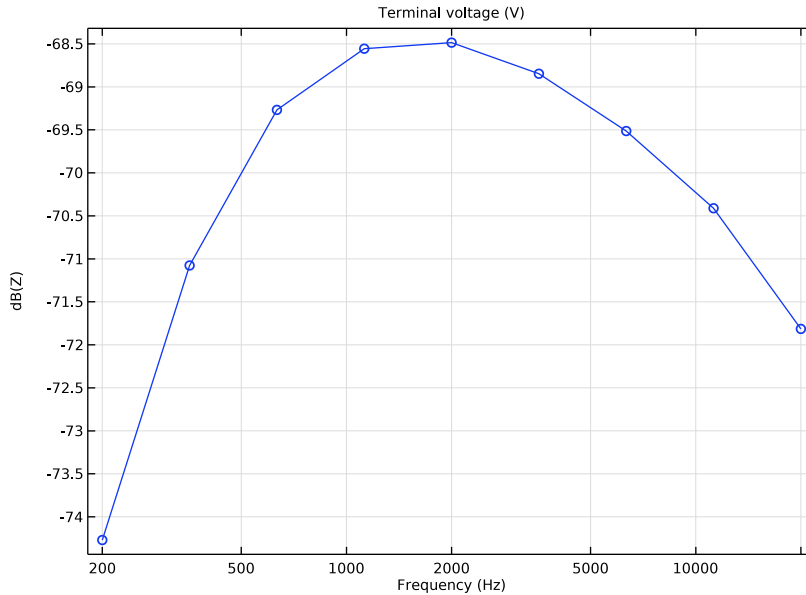

Figure 5: Frequency response of the MEMS microphone.

Notes About the COMSOL Implementation

The multiphysics coupling **Thermoviscous Acoustics–Structure Boundary** does not include the option to set a slip velocity boundary condition in the fluid. Thus, the model uses a manual coupling between the **Thermoviscous Acoustics, Frequency Domain** and **Solid Mechanics** physics interfaces. In the **Slip Wall** node, the **Mechanical condition** is set to **Moving Wall** and the velocity input is chosen to be **Velocity (solid/lemm1)**. In the **Solid Mechanics** interface, a **Boundary Load** is added on the diaphragm, where the **Force per unit area** is set to **Acoustic slip wall traction per unit area (ta/slw2)** picked up from the **Slip Wall** boundary in the **Thermoviscous Acoustics, Frequency Domain** interface.

The size of the model makes it advantageous to use an iterative solver, the suggested iterative solver does not include the variables related to the moving mesh. Therefore, a fourth direct preconditioner is added that contains the variables related to the moving mesh.

Reference

I. P. Loepfert and S. Lee, “Sisonic—the first commercialized MEMS microphone,” *Solid-state sensors, actuators and microsystems workshop, Hilton Head Island, South Carolina*, pp. 27–30, 2006.

Application Library path: Acoustics_Module/Electroacoustic_Transducers/mems_microphone_slip_wall



Modeling Instructions

From the **File** menu, choose **New**.

NEW

In the **New** window, click  **Model Wizard**.

MODEL WIZARD

- 1 In the **Model Wizard** window, click  **3D**.
- 2 In the **Select Physics** tree, select **Acoustics** > **Thermoviscous Acoustics** > **Thermoviscous Acoustics, Frequency Domain (ta)**.
- 3 Click **Add**.
- 4 In the **Select Physics** tree, select **Acoustics** > **Elastic Waves** > **Solid Mechanics (Elastic Waves) (solid)**.
- 5 Click **Add**.
- 6 In the **Select Physics** tree, select **AC/DC** > **Electric Fields and Currents** > **Electrostatics (es)**.
- 7 Click **Add**.
- 8 In the **Select Physics** tree, select **AC/DC** > **Electrical Circuit (cir)**.
- 9 Click **Add**.
- 10 In the **Select Physics** tree, select **Mathematics** > **Deformed Mesh** > **Moving Mesh** > **Free Deformation**.
- 11 Click **Add**.
- 12 In the **Select Physics** tree, select **Mathematics** > **Deformed Mesh** > **Moving Mesh**.
- 13 Click  **Study**.
- 14 In the **Select Study** tree, select **Preset Studies for Some Physics Interfaces** > **Stationary**.

15 Click  **Done**.

GLOBAL DEFINITIONS

Parameters 1

- 1 In the **Model Builder** window, under **Global Definitions** click **Parameters 1**.
- 2 In the **Settings** window for **Parameters**, locate the **Parameters** section.
- 3 Click  **Load from File**.
- 4 Browse to the model's Application Libraries folder and double-click the file `mems_microphone_slip_wall_parameters.txt`.

GEOMETRY 1

- 1 In the **Model Builder** window, expand the **Component 1 (comp1) > Geometry 1** node, then click **Geometry 1**.
- 2 In the **Settings** window for **Geometry**, locate the **Units** section.
- 3 From the **Length unit** list, choose μm .

Cylinder 1 (cyl1)

- 1 In the **Geometry** toolbar, click  **Cylinder**.
- 2 In the **Settings** window for **Cylinder**, locate the **Size and Shape** section.
- 3 In the **Radius** text field, type `dia_r*1`.
- 4 In the **Height** text field, type `200[μm]`.
- 5 Locate the **Position** section. In the **z** text field, type `-100[μm]`.

Diaphragm

- 1 Right-click **Cylinder 1 (cyl1)** and choose **Duplicate**.
- 2 In the **Settings** window for **Cylinder**, locate the **Size and Shape** section.
- 3 In the **Height** text field, type `dia_t`.
- 4 Locate the **Position** section. In the **z** text field, type `0`.
- 5 In the **Label** text field, type `Diaphragm`.

Backplate

- 1 Right-click **Diaphragm** and choose **Duplicate**.
- 2 In the **Settings** window for **Cylinder**, type `Backplate` in the **Label** text field.
- 3 Locate the **Size and Shape** section. In the **Height** text field, type `back_t`.
- 4 Locate the **Position** section. In the **z** text field, type `gap+dia_t`.

Initial hole

- 1 Right-click **Backplate** and choose **Duplicate**.
- 2 In the **Settings** window for **Cylinder**, locate the **Size and Shape** section.
- 3 In the **Radius** text field, type hole_r.
- 4 In the **Label** text field, type Initial hole.

Cylinder 1 (cyl1)



- 1 In the **Model Builder** window, click **Cylinder 1 (cyl1)**.
- 2 In the **Settings** window for **Cylinder**, click to expand the **Layers** section.
- 3 In the table, enter the following settings:

Layer name	Thickness (μm)
Layer 1	85 [μm]
Layer 2	35 [μm]

- 4 Select the **Layers on bottom** checkbox.
- 5 Clear the **Layers on side** checkbox.

Create an array of holes in a hexagonal lattice structure.

Array 1 (arr1)

- 1 In the **Geometry** toolbar, click  **Transforms** and choose **Array**.
- 2 Click the  **Wireframe Rendering** button in the **Graphics** toolbar.
- 3 Select the object **cyl4** only.
- 4 In the **Settings** window for **Array**, locate the **Size** section.
- 5 From the **Array type** list, choose **Linear**.
- 6 In the **Size** text field, type 2.
- 7 Locate the **Displacement** section. In the **x** text field, type hole_dist.

Array 2 (arr2)

- 1 In the **Geometry** toolbar, click  **Transforms** and choose **Array**.
- 2 Select the objects **arr1(1)** and **arr1(2)** only.
- 3 In the **Settings** window for **Array**, locate the **Size** section.
- 4 From the **Array type** list, choose **Linear**.
- 5 In the **Size** text field, type 2.
- 6 Locate the **Displacement** section. In the **x** text field, type hole_dist/2.
- 7 In the **y** text field, type $\sin(\pi/3) \cdot \text{hole_dist}$.

Array 3 (arr3)

- 1 In the **Geometry** toolbar, click  **Transforms** and choose **Array**.
- 2 Select the objects **arr2(1,1)**, **arr2(1,2)**, **arr2(2,1)**, and **arr2(2,2)** only.
- 3 In the **Settings** window for **Array**, locate the **Size** section.
- 4 In the **x size** text field, type 8.
- 5 In the **y size** text field, type 8.
- 6 Locate the **Displacement** section. In the **x** text field, type $2 * \text{hole_dist}$.
- 7 In the **y** text field, type $2 * \sin(\pi/3) * \text{hole_dist}$.
- 8 Locate the **Selections of Resulting Entities** section. Find the **Cumulative selection** subsection. Click **New**.
- 9 In the **New Cumulative Selection** dialog, type **Holes** in the **Name** text field.
- 10 Click **OK**.

Cylinder Selection 1 (cylsel1)

- 1 In the **Geometry** toolbar, click  **Selections** and choose **Cylinder Selection**.
- 2 In the **Settings** window for **Cylinder Selection**, locate the **Geometric Entity Level** section.
- 3 From the **Level** list, choose **Object**.
- 4 Locate the **Input Entities** section. From the **Entities** list, choose **From selections**.
- 5 Click **+ Add**.
- 6 In the **Add** dialog, select **Holes** in the **Selections** list.
- 7 Click **OK**.
- 8 In the **Settings** window for **Cylinder Selection**, locate the **Size and Shape** section.
- 9 In the **Outer radius** text field, type $4 * \text{dia_r}$.
- 10 In the **Inner radius** text field, type $0.75 * \text{dia_r}$.
- 11 Locate the **Output Entities** section. From the **Include entity if** list, choose **Some vertex inside cylinder**.
- 12 Locate the **Resulting Selection** section. Clear the **Keep selection** checkbox.
- 13 Find the **Cumulative selection** subsection. Click **New**.
- 14 In the **New Cumulative Selection** dialog, type **Holes tmp** in the **Name** text field.
- 15 Click **OK**.

Delete Entities 1 (del1)

- 1 In the **Model Builder** window, right-click **Geometry 1** and choose **Delete Entities**.

2 In the **Settings** window for **Delete Entities**, locate the **Entities or Objects to Delete** section.

3 From the **Selection** list, choose **Holes tmp**.

Array 1 (arr1), Array 2 (arr2), Array 3 (arr3), Cylinder Selection 1 (cylsel1), Delete Entities 1 (dell), Initial hole (cyl4)

1 In the **Model Builder** window, under **Component 1 (comp1) > Geometry 1**, Ctrl-click to select **Initial hole (cyl4)**, **Array 1 (arr1)**, **Array 2 (arr2)**, **Array 3 (arr3)**, **Cylinder Selection 1 (cylsel1)**, and **Delete Entities 1 (dell)**.

2 Right-click and choose **Group**.

Holes

In the **Settings** window for **Group**, type Holes in the **Label** text field.

Vent 1

1 In the **Geometry** toolbar, click  **Cylinder**.

2 In the **Settings** window for **Cylinder**, type Vent 1 in the **Label** text field.

3 Locate the **Size and Shape** section. In the **Radius** text field, type vent_r.

4 In the **Height** text field, type back_t.

5 Locate the **Position** section. In the **x** text field, type $\cos(5 \cdot \pi / 180) \cdot \text{vent_d}$.

6 In the **y** text field, type $\sin(5 \cdot \pi / 180) \cdot \text{vent_d}$.

7 In the **z** text field, type gap+dia_t.

8 Locate the **Selections of Resulting Entities** section. Find the **Cumulative selection** subsection. Click **New**.

9 In the **New Cumulative Selection** dialog, type Vents in the **Name** text field.

10 Click **OK**.

Vent 2

1 Right-click **Vent 1** and choose **Duplicate**.

2 In the **Settings** window for **Cylinder**, type Vent 2 in the **Label** text field.

3 Locate the **Position** section. In the **x** text field, type $\cos(15 \cdot \pi / 180) \cdot \text{vent_d}$.

4 In the **y** text field, type $\sin(15 \cdot \pi / 180) \cdot \text{vent_d}$.

Vent 3

1 Right-click **Vent 2** and choose **Duplicate**.

2 In the **Settings** window for **Cylinder**, type Vent 3 in the **Label** text field.

3 Locate the **Position** section. In the **x** text field, type $\cos(25 \cdot \pi / 180) \cdot \text{vent_d}$.

4 In the **y** text field, type $\sin(25*\pi/180)*\text{vent_d}$.

Vent 1 (cyl5), Vent 2 (cyl6), Vent 3 (cyl7)

1 In the **Model Builder** window, under **Component 1 (comp1) > Geometry 1**, Ctrl-click to select **Vent 1 (cyl5)**, **Vent 2 (cyl6)**, and **Vent 3 (cyl7)**.

2 Right-click and choose **Group**.

Vents

In the **Settings** window for **Group**, type **Vents** in the **Label** text field.

Cylinder Selection 2 (cylsel2)

1 In the **Geometry** toolbar, click  **Selections** and choose **Cylinder Selection**.

2 In the **Settings** window for **Cylinder Selection**, locate the **Size and Shape** section.

3 In the **Outer radius** text field, type 1[mm].

4 Locate the **Geometric Entity Level** section. From the **Level** list, choose **Object**.

5 Locate the **Resulting Selection** section. Find the **Cumulative selection** subsection. Click **New**.

6 In the **New Cumulative Selection** dialog, type **AllCyl** in the **Name** text field.

7 Click **OK**.

8 In the **Settings** window for **Cylinder Selection**, click  **Build Selected**.

Union 1 (unil)

1 In the **Geometry** toolbar, click  **Booleans and Partitions** and choose **Union**.

2 In the **Settings** window for **Union**, locate the **Union** section.

3 From the **Input objects** list, choose **AllCyl**.

Use a **Work Plane** and **Intersection** node to create a 30 degree section of the geometry.

Work Plane 1 (wp1)

1 In the **Geometry** toolbar, click  **Work Plane**.



2 In the **Settings** window for **Work Plane**, locate the **Plane Definition** section.

3 In the **z-coordinate** text field, type -100[μm].

Work Plane 1 (wp1) > Plane Geometry

In the **Model Builder** window, expand the **Component 1 (comp1) > Geometry 1 > Work Plane 1 (wp1) > View 2** node, then click **Component 1 (comp1) > Geometry 1 > Work Plane 1 (wp1) > Plane Geometry**.

Work Plane 1 (wpl) > Circle 1 (cl)



- 1 In the **Work Plane** toolbar, click  **Circle**.
- 2 In the **Settings** window for **Circle**, locate the **Size and Shape** section.
- 3 In the **Radius** text field, type `dia_r`.
- 4 In the **Sector angle** text field, type 30.
- 5 In the **Work Plane** toolbar, click  **Build All**.

Extrude 1 (ext1)

- 1 In the **Model Builder** window, right-click **Geometry 1** and choose **Extrude**.
- 2 In the **Settings** window for **Extrude**, locate the **Distances** section.
- 3 In the table, enter the following settings:

Distances (μm)
0.5 [mm]

Intersection 1 (int1)

- 1 In the **Geometry** toolbar, click  **Booleans and Partitions** and choose **Intersection**.
- 2 Select the objects **ext1** and **unil** only.
- 3 In the **Settings** window for **Intersection**, click  **Build All Objects**.

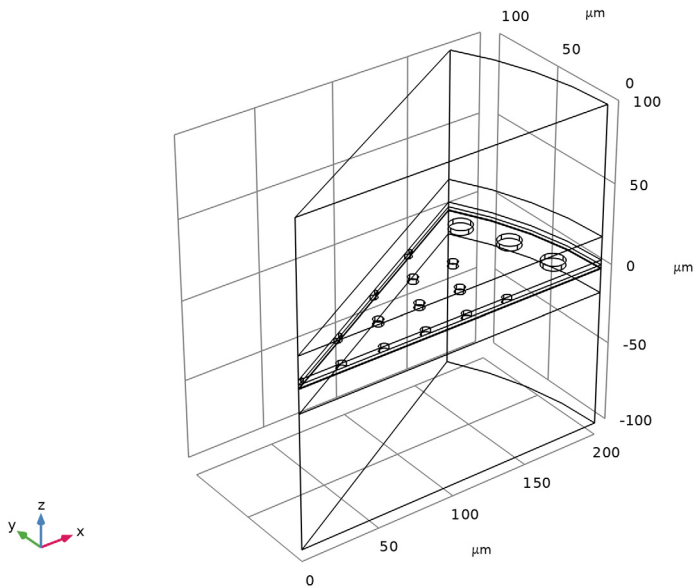



DEFINITIONS

Create selections to make it easier to select domains and surfaces.

Diaphragm

- 1 In the **Definitions** toolbar, click  **Explicit**.
- 2 In the **Settings** window for **Explicit**, type Diaphragm in the **Label** text field.
- 3 Select Domain 3 only.

Diaphragm boundaries

- 1 In the **Definitions** toolbar, click  **Adjacent**.
- 2 In the **Settings** window for **Adjacent**, type Diaphragm boundaries in the **Label** text field.
- 3 Locate the **Input Entities** section. Under **Input selections**, click  **Add**.
- 4 In the **Add** dialog, select **Diaphragm** in the **Input selections** list.
- 5 Click **OK**.



Slip wall boundaries

- 1 In the **Definitions** toolbar, click  **Explicit**.
- 2 In the **Settings** window for **Explicit**, type Slip wall boundaries in the **Label** text field.
- 3 Select Domains 4 and 8 only.
- 4 Locate the **Output Entities** section. From the **Output entities** list, choose **Adjacent boundaries**.
- 5 Select the **Interior boundaries** checkbox.

Large air domain

- 1 In the **Definitions** toolbar, click  **Explicit**.
- 2 In the **Settings** window for **Explicit**, type Large air domain in the **Label** text field.
- 3 Select Domains 1, 2, 4, 6, and 7 only.

Air - TA

- 1 In the **Definitions** toolbar, click  **Union**.
- 2 In the **Settings** window for **Union**, type Air - TA in the **Label** text field.
- 3 Locate the **Input Entities** section. Under **Selections to add**, click  **Add**.
- 4 In the **Add** dialog, in the **Selections to add** list, choose **Large air domain**, **Holes**, and **Vents**.
- 5 Click **OK**.

Symmetry

- 1 In the **Definitions** toolbar, click  **Explicit**.
- 2 In the **Settings** window for **Explicit**, locate the **Input Entities** section.
- 3 From the **Geometric entity level** list, choose **Boundary**.
- 4 Select Boundaries 13 and 14 only.
- 5 Select the **Group by continuous tangent** checkbox.
- 6 In the **Label** text field, type Symmetry.

All domains - Exterior boundaries

- 1 In the **Definitions** toolbar, click  **Explicit**.
- 2 In the **Settings** window for **Explicit**, locate the **Output Entities** section.
- 3 From the **Output entities** list, choose **Adjacent boundaries**.
- 4 Locate the **Input Entities** section. Select the **All domains** checkbox.
- 5 In the **Label** text field, type All domains - Exterior boundaries.

Top of MPP

- 1 In the **Definitions** toolbar, click  **Explicit**.
- 2 In the **Settings** window for **Explicit**, type Top of MPP in the **Label** text field.
- 3 Locate the **Input Entities** section. From the **Geometric entity level** list, choose **Boundary**.
- 4 Select Boundary 15 only.
- 5 Select the **Group by continuous tangent** checkbox.

Air - ACPR

- 1 In the **Definitions** toolbar, click  **Explicit**.
- 2 In the **Settings** window for **Explicit**, type Air - ACPR in the **Label** text field.
- 3 Select Domain 1 only.

Backplate boundaries



- 1 In the **Definitions** toolbar, click  **Explicit**.
- 2 In the **Settings** window for **Explicit**, type Backplate boundaries in the **Label** text field.
- 3 Select Domain 8 only.
- 4 Locate the **Output Entities** section. From the **Output entities** list, choose **Adjacent boundaries**.

Electrostatics domains

- 1 In the **Definitions** toolbar, click  **Union**.

- 2 In the **Settings** window for **Union**, type `Electrostatics` domains in the **Label** text field.
- 3 Locate the **Input Entities** section. Under **Selections to add**, click  **Add**.
- 4 In the **Add** dialog, in the **Selections to add** list, choose **Diaphragm** and **Air - TA**.
- 5 Click **OK**.

ADD MATERIAL

- 1 In the **Materials** toolbar, click  **Add Material** to open the **Add Material** window.
- 2 Go to the **Add Material** window.
- 3 In the tree, select **Built-in > Air** and **Built-in > Silicon**.
- 4 Click the **Add to Component** button in the window toolbar.
- 5 In the **Materials** toolbar, click  **Add Material** to close the **Add Material** window.

MATERIALS

Silicon (mat2)

- 1 In the **Settings** window for **Material**, locate the **Geometric Entity Selection** section.
- 2 From the **Selection** list, choose **Diaphragm**.

Air (mat1)

- 1 In the **Model Builder** window, click **Air (mat1)**.
- 2 In the **Settings** window for **Material**, locate the **Geometric Entity Selection** section.
- 3 From the **Selection** list, choose **All domains**.

MOVING MESH

Deforming Domain 1

- 1 In the **Model Builder** window, expand the **Component 1 (comp1) > Moving Mesh** node, then click **Deforming Domain 1**.
- 2 In the **Settings** window for **Deforming Domain**, locate the **Domain Selection** section.
- 3 Click  **Clear Selection**.
- 4 Select Domains 2 and 4 only.
Set **Mesh smoothing type** to **Laplace** which is more efficient for small perturbations to the mesh.
- 5 Locate the **Smoothing** section. From the **Mesh smoothing type** list, choose **Laplace**.

COMPONENT 1 (COMP1)

Symmetry/Roller 1

- 1 In the **Moving Mesh** toolbar, click  **Symmetry/Roller**.
- 2 In the **Settings** window for **Symmetry/Roller**, locate the **Boundary Selection** section.
- 3 From the **Selection** list, choose **Symmetry**.

THERMOVISCOUS ACOUSTICS, FREQUENCY DOMAIN (TA)

- 1 In the **Model Builder** window, under **Component 1 (comp1)** click **Thermoviscous Acoustics, Frequency Domain (ta)**.
- 2 In the **Settings** window for **Thermoviscous Acoustics, Frequency Domain**, locate the **Domain Selection** section.
- 3 From the **Selection** list, choose **Air - TA**.

Slip Wall 1

In the **Physics** toolbar, click  **Boundaries** and choose **Slip Wall**.

Wall 1

- 1 In the **Model Builder** window, click **Wall 1**.
- 2 In the **Settings** window for **Wall**, locate the **Mechanical** section.
- 3 From the **Mechanical condition** list, choose **Slip (perfect)**.
- 4 Locate the **Thermal** section. From the **Thermal condition** list, choose **Adiabatic**.

Slip Wall - MPP

- 1 In the **Model Builder** window, under **Component 1 (comp1)** > **Thermoviscous Acoustics, Frequency Domain (ta)** click **Slip Wall 1**.
- 2 In the **Settings** window for **Slip Wall**, type Slip Wall - MPP in the **Label** text field.
- 3 Locate the **Boundary Selection** section. From the **Selection** list, choose **Slip wall boundaries**.

Slip Wall - Diaphragm

- 1 In the **Physics** toolbar, click  **Boundaries** and choose **Slip Wall**.
- 2 In the **Settings** window for **Slip Wall**, type Slip Wall - Diaphragm in the **Label** text field.
- 3 Locate the **Boundary Selection** section. From the **Selection** list, choose **Diaphragm boundaries**.
- 4 Locate the **Mechanical** section. From the **Mechanical condition** list, choose **Moving wall**.

- 5 From the u_w list, choose **Velocity (solid/lemm I)**.
Manually couple to the velocity of the diaphragm.

Symmetry 1

- 1 In the **Physics** toolbar, click  **Boundaries** and choose **Symmetry**.
- 2 In the **Settings** window for **Symmetry**, locate the **Boundary Selection** section.
- 3 From the **Selection** list, choose **Symmetry**.

Pressure (Adiabatic) 1

- 1 In the **Physics** toolbar, click  **Boundaries** and choose **Pressure (Adiabatic)**.
- 2 Select Boundary 22 only.
- 3 In the **Settings** window for **Pressure (Adiabatic)**, locate the **Pressure** section.
- 4 In the p_{bnd} text field, type 1 [Pa] .

Wall 2

- 1 In the **Physics** toolbar, click  **Boundaries** and choose **Wall**.
- 2 Select Boundaries 3, 123, and 124 only.

SOLID MECHANICS (SOLID)

- 1 In the **Model Builder** window, under **Component 1 (comp1)** click **Solid Mechanics (solid)**.
- 2 In the **Settings** window for **Solid Mechanics**, locate the **Domain Selection** section.
- 3 From the **Selection** list, choose **Diaphragm**.

Fixed Constraint 1

- 1 In the **Physics** toolbar, click  **Boundaries** and choose **Fixed Constraint**.
- 2 In the **Settings** window for **Fixed Constraint**, locate the **Boundary Selection** section.
- 3 From the **Selection** list, choose **All domains - Exterior boundaries**.

Symmetry 1

- 1 In the **Physics** toolbar, click  **Boundaries** and choose **Symmetry**.
- 2 In the **Settings** window for **Symmetry**, locate the **Boundary Selection** section.
- 3 From the **Selection** list, choose **Symmetry**.

Add a **Boundary Load** to make the manual coupling to the *Thermoviscous Acoustics*.

Boundary Load 1

- 1 In the **Physics** toolbar, click  **Boundaries** and choose **Boundary Load**.
- 2 Select Boundary 12 only.

- 3 In the **Settings** window for **Boundary Load**, locate the **Force** section.
- 4 From the **Load type** list, choose **Force per deformed area**.
- 5 From the f_a list, choose **Acoustic slip wall traction per unit area (ta/slw2)**.

ELECTROSTATICS (ES)

- 1 In the **Model Builder** window, under **Component 1 (comp1)** click **Electrostatics (es)**.
- 2 In the **Settings** window for **Electrostatics**, locate the **Domain Selection** section.
- 3 From the **Selection** list, choose **Electrostatics domains**.

Charge Conservation in Solids I

- 1 In the **Physics** toolbar, click  **Domains** and choose **Charge Conservation in Solids**.
- 2 In the **Settings** window for **Charge Conservation in Solids**, locate the **Domain Selection** section.
- 3 From the **Selection** list, choose **Diaphragm**.

Ground I

- 1 In the **Physics** toolbar, click  **Boundaries** and choose **Ground**.
- 2 Select Boundary 9 only.

Boundary Terminal I

- 1 In the **Physics** toolbar, click  **Boundaries** and choose **Boundary Terminal**.
- 2 In the **Settings** window for **Boundary Terminal**, locate the **Boundary Selection** section.
- 3 From the **Selection** list, choose **Backplate boundaries**.
- 4 Locate the **Terminal** section. From the **Terminal type** list, choose **Circuit**.

Symmetry Plane I

- 1 In the **Physics** toolbar, click  **Boundaries** and choose **Symmetry Plane**.
- 2 In the **Settings** window for **Symmetry Plane**, locate the **Boundary Selection** section.
- 3 From the **Selection** list, choose **Symmetry**.

ELECTRICAL CIRCUIT (CIR)

In the **Model Builder** window, under **Component 1 (comp1)** click **Electrical Circuit (cir)**.

External I vs. U I (IvsUI)

- 1 In the **Electrical Circuit** toolbar, click  **External I vs. U**.
- 2 In the **Settings** window for **External I vs. U**, locate the **External Device** section.
- 3 From the V list, choose **Terminal voltage (es/term1)**.

4 Locate the **Node Connections** section. In the table, enter the following settings:

Label	Node names
p	0
n	1

Resistor 1 (R1)

1 In the **Electrical Circuit** toolbar, click  **Resistor**.

2 In the **Settings** window for **Resistor**, locate the **Node Connections** section.

3 In the table, enter the following settings:

Label	Node names
p	1
n	2

4 Locate the **Device Parameters** section. In the R text field, type 10[Gohm].

Voltage Source 1 (V1)

1 In the **Electrical Circuit** toolbar, click  **Voltage Source**.

2 In the **Settings** window for **Voltage Source**, locate the **Device Parameters** section.

3 In the v_{src} text field, type 1[V].

4 Locate the **Node Connections** section. In the table, enter the following settings:

Label	Node names
p	2
n	0

MULTIPHYSICS

Electromechanics, Solid 1 (eme1)

In the **Model Builder** window, under **Component 1 (comp1)** right-click **Multiphysics** and choose **Electromechanics, Solid**.

Thermoviscous Acoustic–Structure Boundary 1 (tsb1)

1 In the **Model Builder** window, right-click **Multiphysics** and choose **Thermoviscous Acoustic–Structure Boundary**.

2 Select Boundary 9 only.

MESH 1

Size 1

In the **Model Builder** window, under **Component 1 (comp1)** right-click **Mesh 1** and choose **Size**.

Size

- 1 In the **Settings** window for **Size**, locate the **Element Size** section.
- 2 From the **Predefined** list, choose **Finer**.

Size - Holes

- 1 In the **Model Builder** window, click **Size 1**.
- 2 In the **Settings** window for **Size**, locate the **Geometric Entity Selection** section.
- 3 From the **Geometric entity level** list, choose **Domain**.
- 4 From the **Selection** list, choose **Holes**.
- 5 Locate the **Element Size** section. Click the **Custom** button.
- 6 Locate the **Element Size Parameters** section.
- 7 Select the **Maximum element size** checkbox. In the associated text field, type hole_r/1.5.
- 8 In the **Label** text field, type Size - Holes.

Size - Vents

- 1 Right-click **Size - Holes** and choose **Duplicate**.
- 2 In the **Settings** window for **Size**, type Size - Vents in the **Label** text field.
- 3 Locate the **Geometric Entity Selection** section. From the **Selection** list, choose **Vents**.
- 4 Locate the **Element Size Parameters** section. In the **Maximum element size** text field, type vent_r/1.5.

Free Triangular 1

- 1 In the **Mesh** toolbar, click  **More Generators** and choose **Free Triangular**.
- 2 In the **Settings** window for **Free Triangular**, locate the **Boundary Selection** section.
- 3 From the **Selection** list, choose **Top of MPP**.

4 Click  **Build Selected**.

The triangular mesh should be as the following figure.

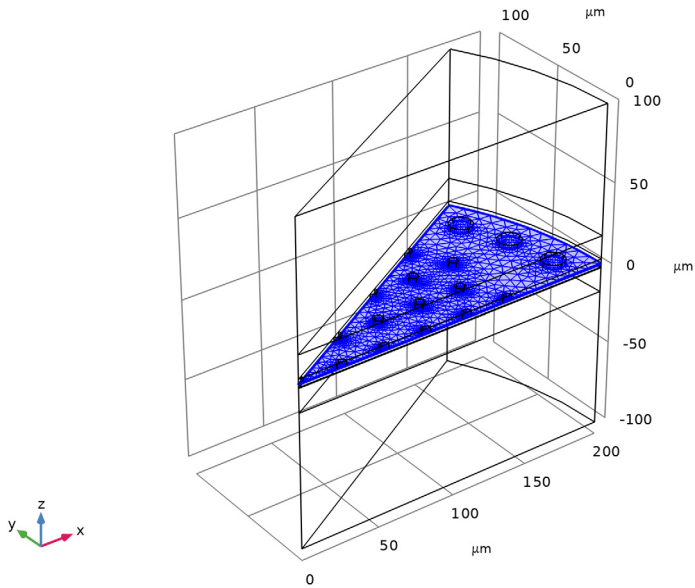

Swept - Gap and diaphragm

- 1 In the **Mesh** toolbar, click  **Swept**.
- 2 In the **Settings** window for **Swept**, type Swept - Gap and diaphragm in the **Label** text field.
- 3 Locate the **Domain Selection** section. From the **Geometric entity level** list, choose **Domain**.
- 4 Select Domains 3 and 4 only.

Distribution 1

- 1 Right-click **Swept - Gap and diaphragm** and choose **Distribution**.
- 2 Select Domain 4 only.
- 3 In the **Settings** window for **Distribution**, locate the **Distribution** section.
- 4 From the **Distribution type** list, choose **Predefined**.
- 5 In the **Element ratio** text field, type 5.
- 6 Select the **Symmetric distribution** checkbox.

Distribution 2

- 1 Right-click **Distribution 1** and choose **Duplicate**.

- 2 In the **Settings** window for **Distribution**, locate the **Distribution** section.
- 3 From the **Distribution type** list, choose **Fixed number of elements**.
- 4 Select Domain 3 only.
- 5 In the **Number of elements** text field, type 2.

Swept - Holes

- 1 In the **Mesh** toolbar, click  **Swept**.
- 2 In the **Settings** window for **Swept**, type Swept - Holes in the **Label** text field.
- 3 Locate the **Domain Selection** section. From the **Geometric entity level** list, choose **Domain**.
- 4 From the **Selection** list, choose **Holes**.

Distribution 1

- 1 Right-click **Swept - Holes** and choose **Distribution**.
- 2 In the **Settings** window for **Distribution**, locate the **Distribution** section.
- 3 From the **Distribution type** list, choose **Predefined**.
- 4 Select the **Symmetric distribution** checkbox.
- 5 In the **Element ratio** text field, type 5.

Swept - Vents

- 1 In the **Model Builder** window, right-click **Swept - Holes** and choose **Duplicate**.
- 2 In the **Settings** window for **Swept**, type Swept - Vents in the **Label** text field.
- 3 Locate the **Domain Selection** section. From the **Selection** list, choose **Vents**.
- 4 Click  **Build Selected**.

Free Tetrahedral 1



- 1 In the **Mesh** toolbar, click  **Free Tetrahedral**.
- 2 In the **Settings** window for **Free Tetrahedral**, locate the **Domain Selection** section.
- 3 From the **Geometric entity level** list, choose **Domain**.
- 4 Select Domains 2 and 6 only.

5 Click  **Build All**.

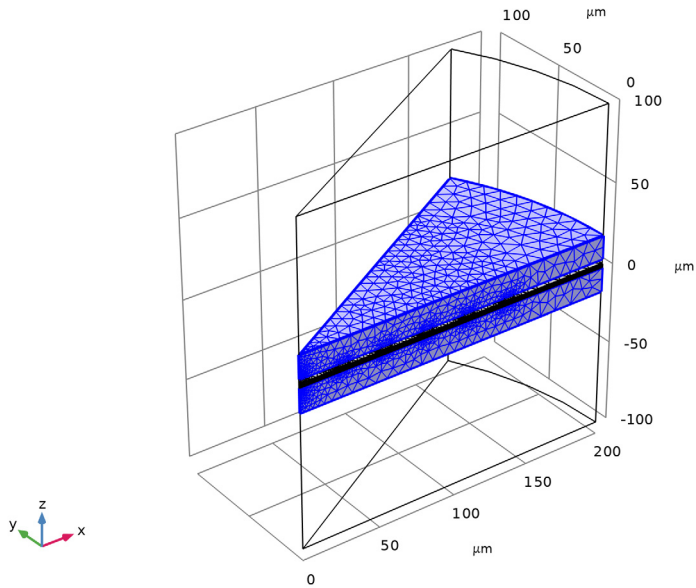
The finalized mesh should be as the following figure.



Swept 4

- 1 In the **Mesh** toolbar, click  **Swept**.
- 2 In the **Settings** window for **Swept**, locate the **Domain Selection** section.
- 3 From the **Geometric entity level** list, choose **Domain**.
- 4 Select Domains 1 and 7 only.
- 5 Click  **Build All**.

STUDY I

Step 2: Frequency-Domain Perturbation

- 1 In the **Model Builder** window, expand the **Study I** node.
- 2 Right-click **Study I** and choose **More Study Steps > Frequency Domain > Frequency-Domain Perturbation**.
- 3 In the **Settings** window for **Frequency-Domain Perturbation**, locate the **Study Settings** section.
- 4 In the **Frequencies** text field, type $10^{\{\text{range}(\log_{10}(200), 1/4, \log_{10}(20000))\}}$.

5 From the **Tolerance** list, choose **User controlled**.

6 In the **Relative tolerance** text field, type 1e-3.

Solution 1 (sol1)

1 In the **Study** toolbar, click  **Show Default Solver**.

2 In the **Model Builder** window, expand the **Solution 1 (sol1)** node.

3 In the **Model Builder** window, expand the **Study 1 > Solver Configurations > Solution 1 (sol1) > Stationary Solver 2** node.

4 Right-click **Study 1 > Solver Configurations > Solution 1 (sol1) > Stationary Solver 2 > Suggested Iterative Solver (GMRES with Direct Precond.) (tsbl_eme1)** and choose **Enable**.

5 In the **Study** toolbar, click  **Compute**.

RESULTS

In the **Model Builder** window, expand the **Results** node.

Sector 3D 1

1 In the **Model Builder** window, expand the **Results > Datasets** node.

2 Right-click **Results > Datasets** and choose **More 3D Datasets > Sector 3D**.

3 In the **Settings** window for **Sector 3D**, locate the **Symmetry** section.

4 In the **Number of sectors** text field, type 12.

5 From the **Sectors to include** list, choose **Manual**.

6 In the **Number of sectors to include** text field, type 12.

7 From the **Transformation** list, choose **Rotation and reflection**.

8 Click  **Plot**.

Sector 3D 2

1 Right-click **Sector 3D 1** and choose **Duplicate**.

2 In the **Settings** window for **Sector 3D**, locate the **Symmetry** section.

3 In the **Number of sectors** text field, type 12.

4 In the **Number of sectors to include** text field, type 9.

5 In the **Start sector** text field, type -2.



6 Click  **Plot**.

Frequency Response

1 In the **Results** toolbar, click  **ID Plot Group**.

- 2 In the **Settings** window for **ID Plot Group**, type Frequency Response in the **Label** text field.

Octave Band 1

- 1 In the **Frequency Response** toolbar, click  **More Plots** and choose **Octave Band**.
- 2 In the **Settings** window for **Octave Band**, locate the **Selection** section.
- 3 From the **Geometric entity level** list, choose **Global**.
- 4 Locate the **y-Axis Data** section. In the **Expression** text field, type `es.V0_1`.
- 5 Click  **Replace Expression**.
- 6 In the **Amplitude reference** text field, type `1/sqrt(2)`.
- 7 Locate the **Plot** section. From the **Quantity** list, choose **Continuous power spectral density**.
- 8 Click to expand the **Coloring and Style** section. Find the **Line markers** subsection. From the **Marker** list, choose **Circle**.
- 9 In the **Frequency Response** toolbar, click  **Plot**.

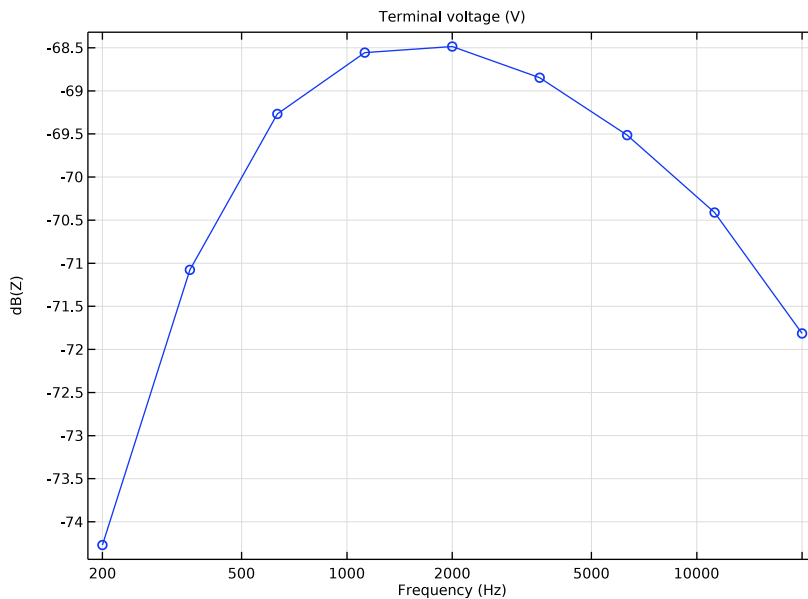

Acoustic Pressure

- 1 In the **Results** toolbar, click  **3D Plot Group**.

- 2 In the **Settings** window for **3D Plot Group**, type Acoustic Pressure in the **Label** text field.
- 3 Locate the **Color Legend** section. Select the **Show units** checkbox.

TA

- 1 Right-click **Acoustic Pressure** and choose **Surface**.
- 2 In the **Settings** window for **Surface**, type TA in the **Label** text field.
- 3 Locate the **Coloring and Style** section. From the **Color table** list, choose **Wave**.
- 4 From the **Scale** list, choose **Linear symmetric**.
- 5 In the **Acoustic Pressure** toolbar, click  **Plot**.

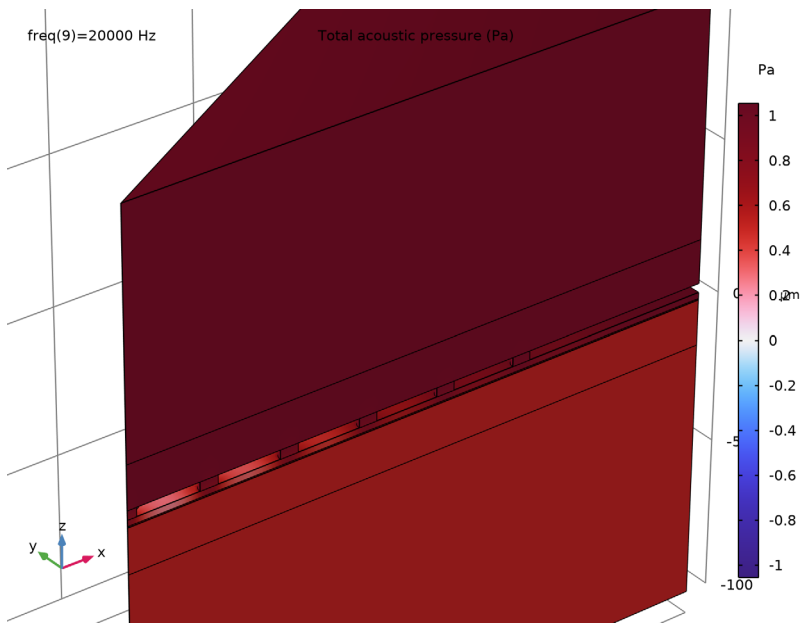

Acoustic Velocity

- 1 In the **Results** toolbar, click  **3D Plot Group**.
- 2 In the **Settings** window for **3D Plot Group**, type Acoustic Velocity in the **Label** text field.
- 3 Locate the **Color Legend** section. Select the **Show units** checkbox.

Surface 1

- 1 Right-click **Acoustic Velocity** and choose **Surface**.
- 2 In the **Settings** window for **Surface**, locate the **Expression** section.

3 In the **Expression** text field, type `ta.v_rms`.

4 From the **Unit** list, choose **mm/s**.

5 In the **Acoustic Velocity** toolbar, click  **Plot**.

