



Model created in COMSOL Multiphysics 6.4

# Lumped Receiver with Full Vibroacoustic Coupling

## Introduction

---

When simulations are involved in the development of mobile devices, consumer electronics, hearing aids, or headsets, it is necessary to consider how the transducers interact with the rest of the system. Here, we will show the analysis of the interaction between a vibration isolation mounting and a miniature hearing aid transducer using a lumped representation of the transducer. The lumped model is simplified as an equivalent electroacoustic circuit. The vibration and acoustic characteristics of the lumped model are then coupled to a multiphysics model of the vibration isolation system to achieve a full system analysis.

In this model, the miniature hearing aid transducer is a Knowles™ TEC-30033 balanced armature receiver, a miniature loudspeaker commonly used in high performance hearing aid packages. A common method of vibration isolation of a receiver is to attach it to the free end of a cantilevered tube. The tube channels the sound to the ear tips and the ear canal and at the same time it reduces the vibration energy transmitted back to the hearing aid package, see [Figure 1](#). This model replicates a test setup that consists of a silicone tube of length 9 mm and inner diameter 1 mm that is attached to a 2 cc coupler, a common cavity of 2 cm<sup>3</sup> utilized as an acoustic load. The setup is illustrated in [Figure 5](#).

The receiver's internal electrical, magnetic, mechanical, and acoustic properties are linearized and represented with an electrical network topology<sup>1</sup>. The mechanical forces within the network are probed and applied as rigid body loads to the receiver. The output acoustic pressure and probed rigid body motion of the receiver are coupled to a finite element (FEM) model of the silicone tubing attachment and acoustic coupler. The thermoviscous losses in the narrow tubing are included using the homogenized approach offered by the *Narrow Region Acoustics* feature in the *Pressure Acoustics, Frequency Domain* interface.

The simulated acoustic response measured in the coupler and the vibration characteristics obtained in the model are compared to measurements. The acoustic response is obtained from the coupler microphone and the vibration characteristics from laser vibrometer measurements.

The model shows how to set up the coupling between the equivalent circuit model (a SPICE representation) and the rigid domain used to model the receiver. This approach allows a full system simulation of, for example, a hearing aid without the need of a detailed receiver model. This can be used to study the full vibroacoustic feedback path between the receiver (miniature loudspeaker) and microphones.

---

1. This model was created based upon data provided by Knowles Electronics LLC, Illinois USA.

---

**Note:** This model is an extension of the [Lumped Receiver Connected to Test Setup with a 0.4-cc Coupler](#) tutorial where only the acoustics are considered. The current tutorial also considers a different model of balanced armature receiver.

---

**Note:** This model requires the Acoustics Module, the Structural Mechanics Module, and the AC/DC Module.

---

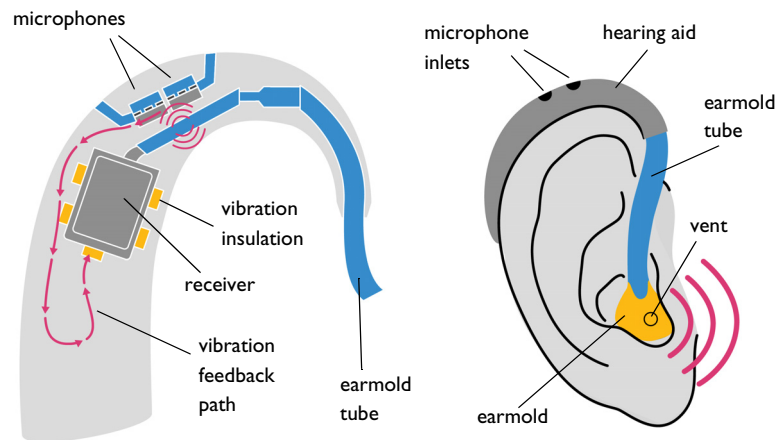

*Figure 1: (left) Schematic representation of the vibration feedback path from the receiver (miniature loudspeaker) to the microphones in a behind-the-ear (BTE) hearing aid. (right) Schematic of how a BTE is placed on the human ear including the vent where sound leaks.*

### *Model Definition*

---

Miniature loudspeaker and other transducers are used in many modern consumer electronics products like smartphones, ear buds, tablets, and hearing aids. In most of these applications, it is desirable to optimize the sound quality and miniaturize the product. For certain applications, like hearing aids, the maximal output level is also important. In all cases, understanding the acoustic and vibrational behavior is important in order to prevent, for example, feedback effects. The specific example of the integration of a balanced armature receiver (or simply receiver, the name given for the miniature

loudspeaker in hearing aids) into a behind-the-ear or BTE hearing aid is schematically depicted in [Figure 1](#). The figure shows a cross section of the hearing aid, location of the transducers, earmold tubing, and the possible feedback path. The feedback path is generated by either the sound in the tubing (generating vibrations that couple to the microphones), directly as mechanical vibrations (red arrows), or by all acoustic when sound is transmitted through the earmold tube, ear canal, and vent to the microphones. These different feedback paths need to be understood and possibly isolated.

A fully detailed multiphysics vibroelectroacoustic model of a miniature transducer is in itself very complex. A rendering of a balanced armature receiver type transducer can be seen in [Figure 2](#). This means that the task of understanding its system integration can easily become computationally expensive if all physics are modeled in detail with a FEM model. That is why a lumped representation of both the electroacoustic behavior and the vibration characteristics of the transducers is desirable to enable a full system simulation.

Specifically in this tutorial, a Knowles™ TEC-30033 receiver is modeled by a lumped equivalent circuit (see [Figure 4](#)) coupled to the motion of a rigid body domain with the mass properties of the transducer (see [Figure 3](#)). The rigid domain is characterized by its center of mass  $\mathbf{X}_{cm}$  and moment of inertia  $\mathbf{I}$ . Both can be extracted from a detailed CAD drawing of the transducer. In COMSOL, this can be done using the **Mass Properties** feature found under the **Definitions** node.

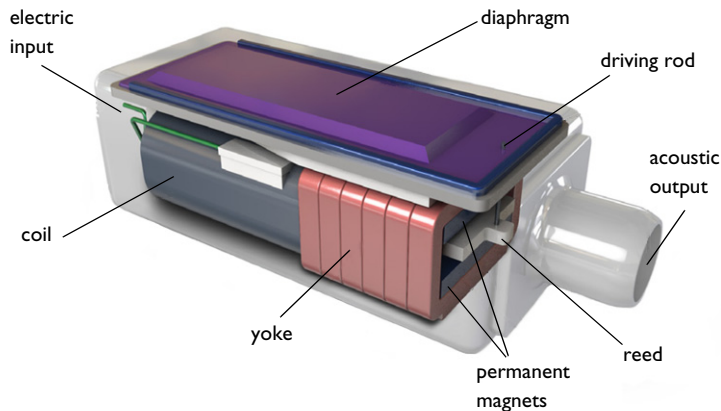

*Figure 2: Rendering of the inner structure of a balanced armature receiver, © Knowles Electronics LLC. Detailed modeling of the system is very computationally demanding and requires coupling electromagnetic fields, structural vibrations and acoustics including thermoviscous losses. Image courtesy of Knowles Electronics LLC, Illinois USA.*

Since the orientation and location of the receiver can be arbitrary in a full system simulation, its mechanical properties are given with respect to the geometric center  $\mathbf{X}_g$  of the receiver box and local orientation of the receiver. The geometric center of the rigid domain corresponding to the receiver is calculated in the model using the **Mass Properties** feature with a unit density expression. The orientation of the transducer is given by setting up a **Base Vector System** defined through a geometry **Work Plane** (placed on top of the receiver box). The work plane and local coordinate system can be seen in [Figure 3](#). Using this approach, the location and orientation of the transducer is easily defined.

The location of the center of mass  $\mathbf{X}_{cm}$  in the global coordinate system is then given by

$$\mathbf{X}_{cm} = \mathbf{X}_g + [T_{ij}]^{-1} \mathbf{X}_{cm}^{local} \quad (1)$$

where  $\mathbf{X}_{cm}^{local}$  is the center-of-mass in the local receiver system of coordinates and  $[T_{ij}]^{-1}$  is the coordinate transformation matrix. The transformation matrix is automatically defined by the **Base Vector System** feature. The components are given by the variables `sys2.inVT11`, `sys2.inVT12`, `sys2.inVT13`, and so on. The center-of-mass coordinates are defined as variables under the **Receiver Variables** node in the **Definitions**.

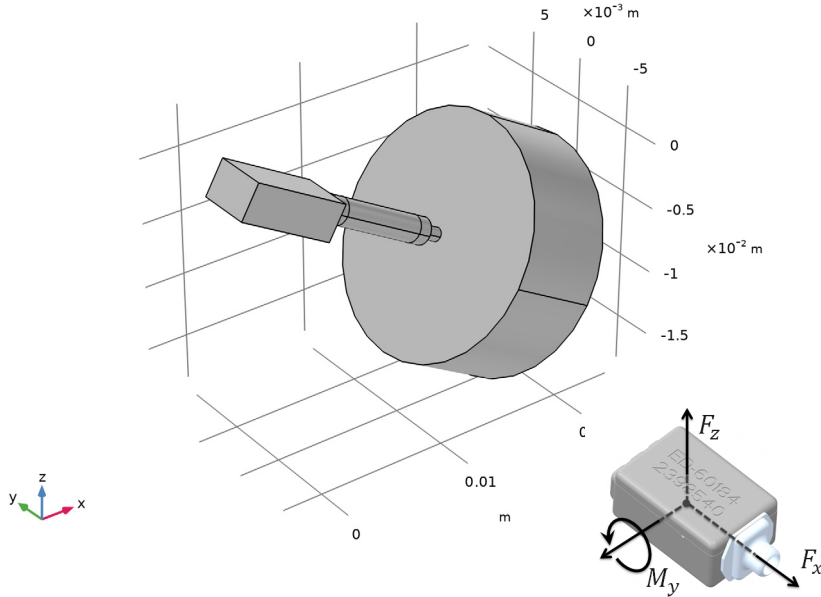

*Figure 3: Local coordinate system defined by adding a work plane at the receiver box surface. In the inset, a schematic of the applied forces and moment on the receiver, © Knowles Electronics LLC. These are due to the movement of the armature and diaphragm (see [Figure 2](#)). Image courtesy of Knowles Electronics LLC, Illinois USA.*

The circuit model topology of the transducer is depicted in [Figure 4](#). The equivalent circuit network is imported as a **Subcircuit Definition** in the **Electrical Circuit** interface. Such a network is capable to capture the electroacoustic performance of most balanced armature receivers produced by Knowles. The network represents the electromagnetic, mechanical, and acoustic parts of the receiver (different colors in the diagram). The acoustics in the circuit are bidirectionally coupled to the finite element domain using the **Circuit** connection option of the **Lumped Port** condition.

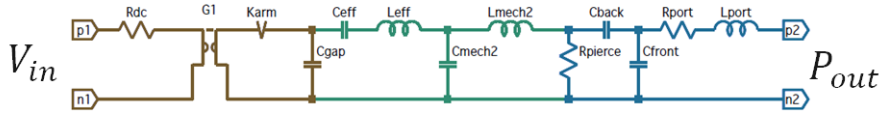

*Figure 4: Lumped circuit representation of the balanced armature receiver, © Knowles Electronics LLC. Note that the  $K_{arm}$  component is a semi capacitor in this schematic. In the COMSOL implementation it is replaced by a resistor with a frequency dependent resistance. Image courtesy of Knowles Electronics LLC, Illinois USA.*

The vibration characteristics of the receiver are modeled by applying a force and moment to the center of mass of the rigid domain. The mechanical vibration coupling is only active one way, since the influence of external vibrations is low under normal operating conditions. On the other hand, the acoustics has to be bidirectionally coupled. The applied forces and moment (in the local receiver coordinate system) can be seen in the inset of [Figure 3](#). The values are given by the variables  $F_x$ ,  $F_z$ , and  $M_y$ , also defined in the **Receiver Variables**. The values are defined by:

$$\begin{aligned}
 F_x &= F_{x1} * \text{cir.X1.LEFF.v} + F_{x2} * \text{cir.X1.LMECH2.v} \\
 F_z &= F_{z1} * \text{cir.X1.LEFF.v} + F_{z2} * \text{cir.X1.LMECH2.v} \\
 M_y &= M_{y1} * \text{cir.X1.LEFF.v} + M_{y2} * \text{cir.X1.LMECH2.v}
 \end{aligned}$$

They relate the voltages in the mechanical part of the spice system to the external forces and moment. The proportionality constants  $F_{x1}$ ,  $F_{x2}$ ,  $F_{z1}$ ,  $F_{z2}$ ,  $M_{y1}$ , and  $M_{y2}$  are defined under the **Parameters** node and are unique to each receiver model.

## Results and Discussion

The simulated system corresponds to the actual vibration isolation test setup depicted in [Figure 5](#). The system consists of the TEC-30033 receiver, the flexible tubing, and the 2 cc coupler volume. In the experiment, the pressure response is measured by the measurement microphone in the coupler and the vibrations of the transducer are measured using a laser

vibrometer. The simulated pressure and vibration response are compared with experimental data.

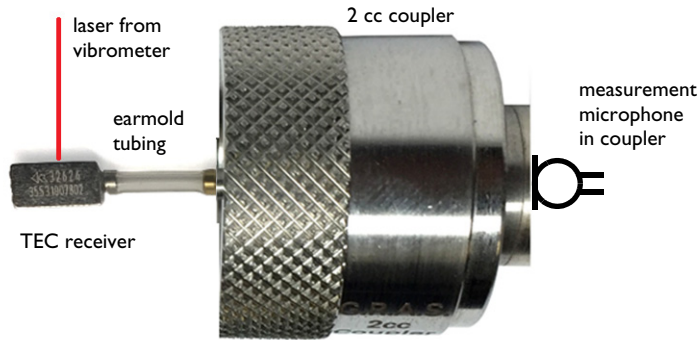

*Figure 5: Experimental setup consisting of the TEC receiver, earmold tubing, and 2 cc coupler, © Knowles Electronics LLC. The acoustic response is measured by the microphone located in the coupler and the vibrations of the receiver are measured by a laser vibrometer. Image courtesy of Knowles Electronics LLC, Illinois USA.*

The sound pressure level response in the coupler is depicted in [Figure 6](#). The agreement between the measurements and the COMSOL simulation is good. Note that the measurements only have been done from 100 Hz up to 10 kHz. Discrepancies at the highest frequencies are expected since the lumped transducer representation is not fully valid at the highest frequencies.

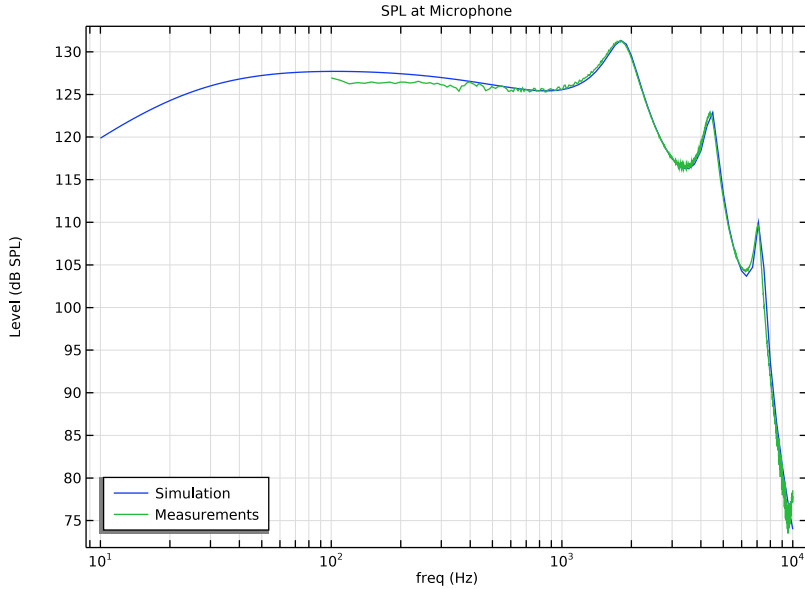

Figure 6: Sound pressure level at the microphone. Comparison of the simulation results (blue curve) and the measurements results (green curve).

The vibration response, defined by the velocity amplitude in the local x and z directions, is depicted in Figure 7 and Figure 8. The measured data includes two measurement series that were performed independently by two groups in the hearing aid industry. The results show good agreement, but also indicate the sensitivity in the measurements. Small changes in the actual earmold tube length or variations the material properties of the silicone tubing, can change both the amplitude and the location of resonances. This type of sensitivity can be studied using simulations by changing the geometry or material parameters. The simulated velocity amplitudes are shown for two different points to demonstrate the sensitivity of where the measurements are performed. This is especially important for the velocity amplitude in the z direction.

The velocity response in the local y direction is depicted in Figure 9. Because of the orientation of the model and the applied forces the values are considered to be numerical noise. Notice the low values in the dB scale.

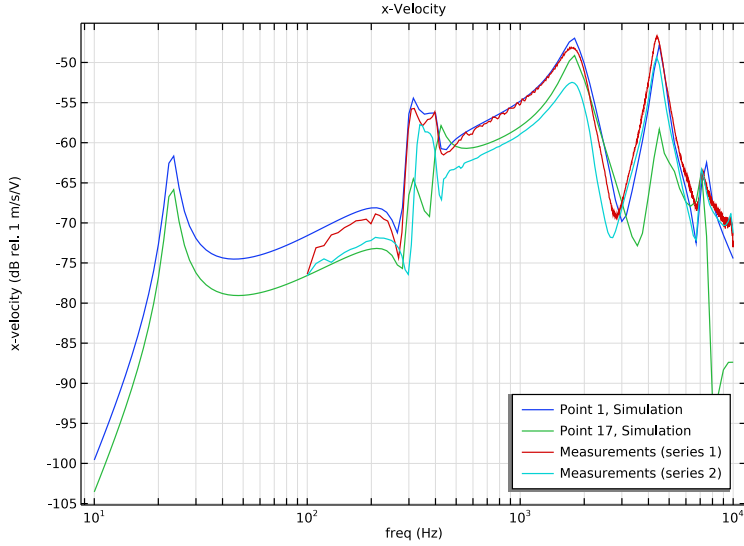

Figure 7: Vibration velocity in the (local)  $x$  direction (see inset in Figure 3). Comparison between the simulation results and two independent measurements series.

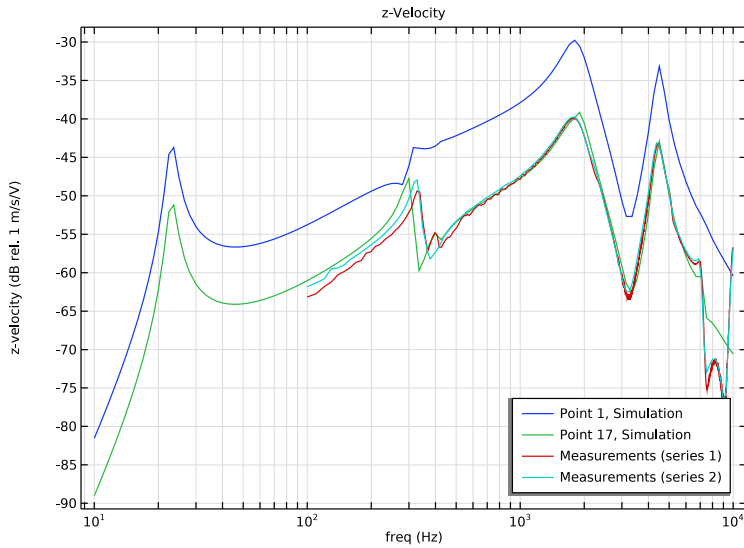
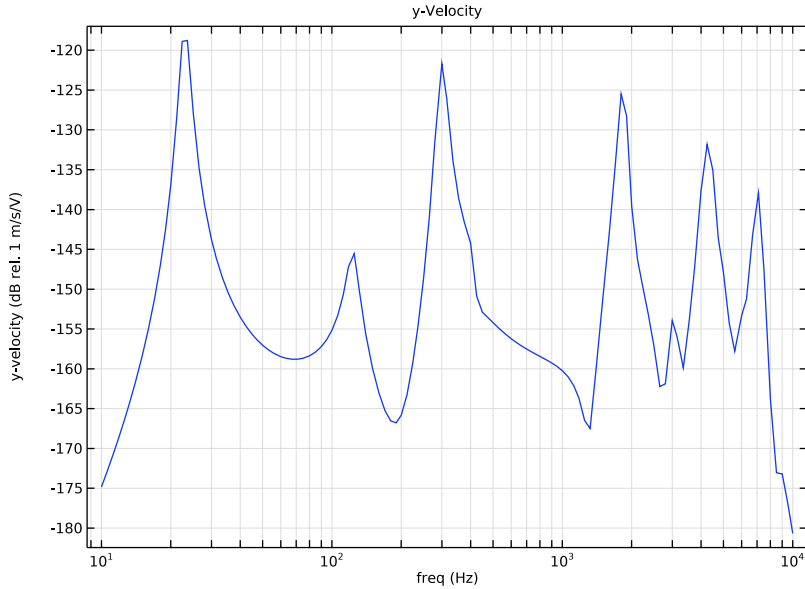
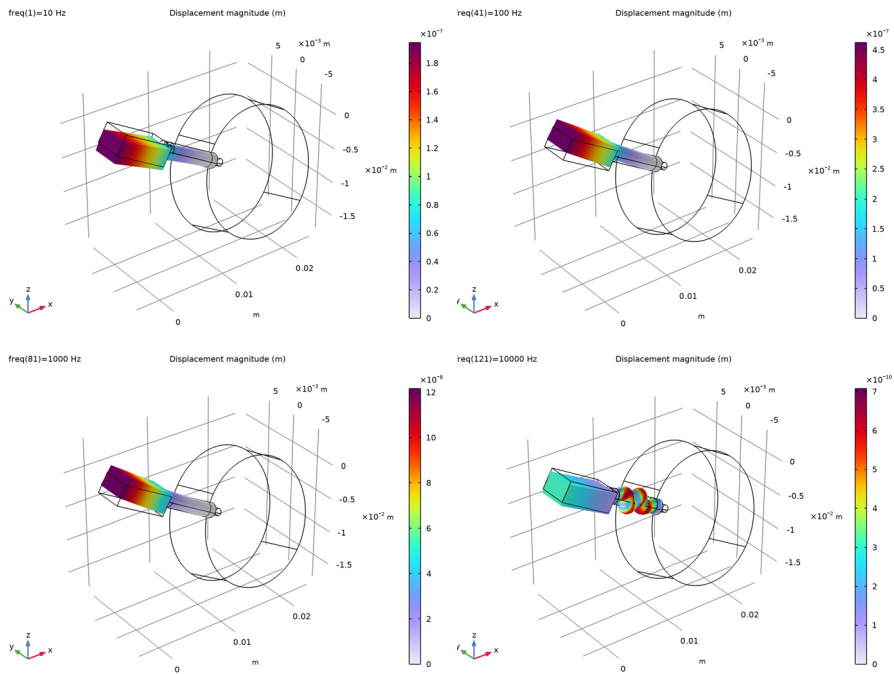

Figure 8: Vibration velocity in the (local)  $z$  direction (see inset in Figure 3). Comparison between the simulation results and two independent measurements series.



*Figure 9: Vibration velocity in the (local) y direction. The values are so low that this basically corresponds to numerical noise.*

The displacement of the transducer and the earmold tubing, the pressure distribution in the earmold tubing and the coupler, as well as the sound pressure level distribution, is depicted at the frequencies 10 Hz, 100 Hz, 1 kHz, and 10 kHz in [Figure 10](#), [Figure 11](#), and [Figure 12](#), respectively. Detailed analysis of the frequency characteristics at the other studied frequencies can be seen in the model where the system is solved from 10 Hz to 10 kHz in 1/12 th octave steps.



*Figure 10: Displacement of the receiver and earmold tubing for 10 Hz, 100 Hz, 1 kHz, and 10 kHz.*

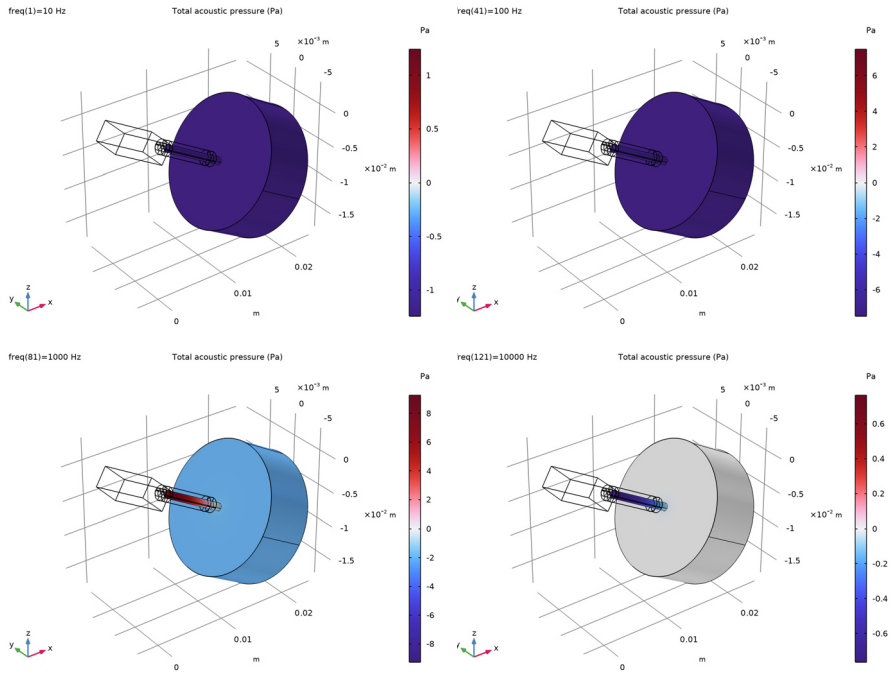

Figure 11: Pressure distribution in the earmold tubing and coupler volume for 10 Hz, 100 Hz, 1 kHz, and 10 kHz.

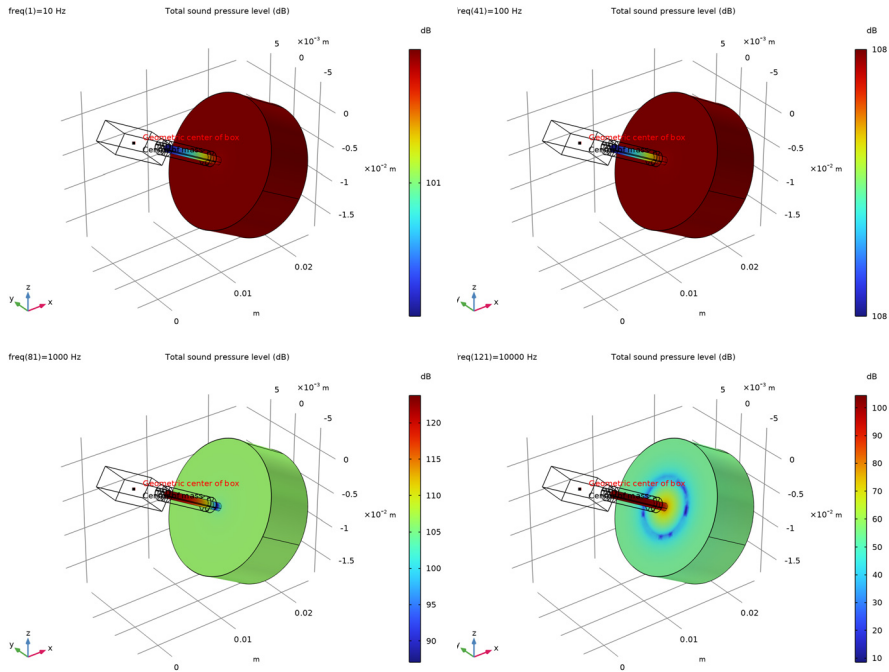

Figure 12: Sound pressure level distribution in the earmold tubing and coupler volume for 10 Hz, 100 Hz, 1 kHz, and 10 kHz.

### Notes About the COMSOL Implementation

- In this model, the viscous and thermal losses associated with the acoustic boundary layer in the narrow tube are modeled using the Narrow Region Acoustics feature in Pressure acoustics. The computational cost is low compared to a full thermoviscous acoustics model and for long structures of constant cross section the losses are exact. However, for complex geometrical structures, the Thermoviscous Acoustics interfaces should be used. Note also that the losses associated with the impedance jump from the narrow tube to the coupler are not included.
- The Electrical Circuit interface uses electrical units. Conversion from electrical to acoustic lumped units are performed automatically in the Lumped port feature with the necessary units. For example, a voltages representing the acoustic pressure at the transducer inlet is transformed to volts, resulting in correct equivalent electric units volts.

- In the lumped equivalent circuit model of the receiver, the effects of variation in the skin depth of eddy currents in the steel armature is approximated by a semi-capacitor, a special component with a complex admittance proportional to the square root of  $i\omega$ . In the imported SPICE circuit equivalent topology network list (in the model the file `lumped_receiver_vibroacoustic_TEC30033.cir` is imported), the value of this component, here a resistor, is temporarily set to 1, using:

```
RKarm KN020 KN040 1
```

Then the correct value for this component is entered manually, as a formula, to fit the COMSOL notation:

```
1[ohm]/(G_arm*sqrt(i*2*pi*freq[1/Hz]))
```

Where `G_arm` is a constant valued gain parameter.

---

**Application Library path:** `Acoustics_Module/Electroacoustic_Transducers/lumped_receiver_vibroacoustic`

---

### *Modeling Instructions*

---

These are the modeling instructions for setting up the model, solving, and creating the postprocessing plots. The [Geometry Modeling Instructions](#) are located in the last section at the end of this document.

From the **File** menu, choose **New**.

#### **NEW**

In the **New** window, click  **Model Wizard**.

#### **MODEL WIZARD**

- 1 In the **Model Wizard** window, click  **3D**.
- 2 In the **Select Physics** tree, select **AC/DC > Electrical Circuit (cir)**.
- 3 Click **Add**.
- 4 In the **Select Physics** tree, select **Structural Mechanics > Solid Mechanics (solid)**.
- 5 Click **Add**.
- 6 In the **Select Physics** tree, select **Acoustics > Pressure Acoustics > Pressure Acoustics, Frequency Domain (acpr)**.
- 7 Click **Add**.

- 8 Click  **Study**.
- 9 In the **Select Study** tree, select **General Studies > Frequency Domain**.
- 10 Click  **Done**.

## GLOBAL DEFINITIONS



### *Parameters 1*

- 1 In the **Model Builder** window, under **Global Definitions** click **Parameters 1**.
- 2 In the **Settings** window for **Parameters**, locate the **Parameters** section.
- 3 Click  **Load from File**.
- 4 Browse to the model's Application Libraries folder and double-click the file `lumped_receiver_vibroacoustic_parameters.txt`.

## GEOMETRY 1

- 1 In the **Geometry** toolbar, click **Insert Sequence** and choose **Insert Sequence**.
- 2 Browse to the model's Application Libraries folder and double-click the file `lumped_receiver_vibroacoustic_geom_sequence.mph`.
- 3 In the **Geometry** toolbar, click  **Build All**.

### *Work Plane 3 (wp3)*

- 1 In the **Geometry** toolbar, click  **Work Plane**.
- 2 In the **Settings** window for **Work Plane**, locate the **Plane Definition** section.
- 3 From the **Plane type** list, choose **Face parallel**.
- 4 Click the  **Zoom Extents** button in the **Graphics** toolbar.

- 5 On the object **rotl(1)**, select Boundary 4 only.

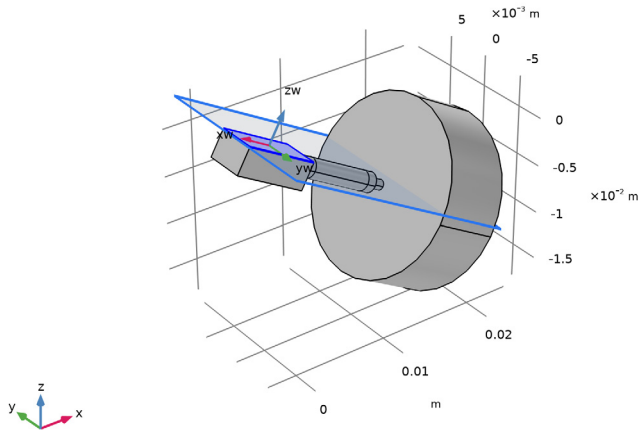

- 6 Click to expand the **Local Coordinate System** section. In the **Rotation** text field, type 180.

- 7 Click  **Build All Objects**.

The geometry with the coordinate system created by the work plane is depicted in [Figure 3](#). The local coordinate system is used for orienting the applied forces and moment on the receiver.

Proceed to the **Definitions** node and add variables, create selections, integration operators, and add the **Mass Properties** node. The last is used to calculate the geometric center of the receiver box. The center of mass and other quantities are defined relative to the geometric center.

## DEFINITIONS



### Main Variables

- 1 In the **Model Builder** window, expand the **Component 1 (comp1) > Definitions** node.
- 2 Right-click **Definitions** and choose **Variables**.
- 3 In the **Settings** window for **Variables**, type Main Variables in the **Label** text field.
- 4 Locate the **Variables** section. Click  **Load from File**.
- 5 Browse to the model's Application Libraries folder and double-click the file `lumped_receiver_vibroacoustic_variables_main.txt`.

### *Receiver Variables*

- 1 Right-click **Definitions** and choose **Variables**.
- 2 In the **Settings** window for **Variables**, type Receiver Variables in the **Label** text field.
- 3 Locate the **Variables** section. Click  **Load from File**.
- 4 Browse to the model's Application Libraries folder and double-click the file `lumped_receiver_vibroacoustic_variables_receiver.txt`.

### *Mass Properties 1 (mass1)*

- 1 Right-click **Definitions** and choose **Physics Utilities > Mass Properties**.
- 2 In the **Settings** window for **Mass Properties**, locate the **Source Selection** section.
- 3 Click  **Clear Selection**.
- 4 Click the  **Zoom Extents** button in the **Graphics** toolbar.
- 5 Select Domain 1 only.
- 6 Click the  **Wireframe Rendering** button in the **Graphics** toolbar.

### *Transducer*

- 1 In the **Definitions** toolbar, click  **Explicit**.
- 2 In the **Settings** window for **Explicit**, type Transducer in the **Label** text field.
- 3 Select Domains 1, 2, and 5 only.

### *Inner Tube*

- 1 In the **Definitions** toolbar, click  **Explicit**.
- 2 In the **Settings** window for **Explicit**, type Inner Tube in the **Label** text field.
- 3 Select Domains 10, 16, and 19 only.

### *Acoustic-Structure Interaction*

- 1 In the **Definitions** toolbar, click  **Explicit**.
- 2 In the **Settings** window for **Explicit**, type Acoustic-Structure Interaction in the **Label** text field.
- 3 Locate the **Input Entities** section. From the **Geometric entity level** list, choose **Boundary**.
- 4 Select Boundaries 35, 36, 40, and 43 only.

### *Inlet*

- 1 In the **Definitions** toolbar, click  **Explicit**.
- 2 In the **Settings** window for **Explicit**, type Inlet in the **Label** text field.
- 3 Locate the **Input Entities** section. From the **Geometric entity level** list, choose **Boundary**.

4 Select Boundary 34 only.



#### *Microphone*

- 1 In the **Definitions** toolbar, click  **Explicit**.
- 2 In the **Settings** window for **Explicit**, type Microphone in the **Label** text field.
- 3 Locate the **Input Entities** section. From the **Geometric entity level** list, choose **Boundary**.
- 4 Select Boundary 78 only.

#### *Silicone Tubing*

- 1 In the **Definitions** toolbar, click  **Explicit**.
- 2 In the **Settings** window for **Explicit**, type Silicone Tubing in the **Label** text field.
- 3 Select Domains 3, 4, 6–9, 11, 12, 14, 15, 17, and 18 only.

#### *Solid Domains*

- 1 In the **Definitions** toolbar, click  **Union**.
- 2 In the **Settings** window for **Union**, type Solid Domains in the **Label** text field.
- 3 Locate the **Input Entities** section. Under **Selections to add**, click  **Add**.
- 4 In the **Add** dialog, in the **Selections to add** list, choose **Transducer** and **Silicone Tubing**.
- 5 Click **OK**.

#### *Air Domains*

- 1 In the **Definitions** toolbar, click  **Explicit**.
- 2 In the **Settings** window for **Explicit**, type Air Domains in the **Label** text field.
- 3 Select Domains 10, 13, 16, and 19 only.

#### *Integration 1 (intop1)*

- 1 In the **Definitions** toolbar, click  **Nonlocal Couplings** and choose **Integration**.
- 2 In the **Settings** window for **Integration**, type intop\_mic in the **Operator name** text field.
- 3 Locate the **Source Selection** section. From the **Geometric entity level** list, choose **Boundary**.
- 4 From the **Selection** list, choose **Microphone**.

Use the coordinates defined in **Work Plane 3** to define a base vector coordinate system to be used in the physics. Then proceed to setting up the materials.

#### *Base Vector System 2 (sys2)*

- 1 In the **Definitions** toolbar, click  **Coordinate Systems** and choose **Base Vector System**.

- 2 In the **Settings** window for **Base Vector System**, locate the **Relative to System from Geometry** section.
- 3 From the **Work plane** list, choose **Work Plane 3 (wp3)**.

#### DEFINITIONS

In the **Model Builder** window, collapse the **Component 1 (comp1) > Definitions** node.

#### GEOMETRY 1

In the **Model Builder** window, collapse the **Component 1 (comp1) > Geometry 1** node.

#### ADD MATERIAL

- 1 In the **Materials** toolbar, click  **Add Material** to open the **Add Material** window.
- 2 Go to the **Add Material** window.
- 3 In the tree, select **Built-in > Air**.
- 4 Click the **Add to Component** button in the window toolbar.

#### MATERIALS

*Air (mat1)*

- 1 In the **Settings** window for **Material**, locate the **Geometric Entity Selection** section.
- 2 From the **Selection** list, choose **Air Domains**.

*Tubing (Silicone)*

- 1 In the **Model Builder** window, right-click **Materials** and choose **Blank Material**.
- 2 In the **Settings** window for **Material**, type **Tubing (Silicone)** in the **Label** text field.
- 3 Locate the **Geometric Entity Selection** section. From the **Selection** list, choose **Silicone Tubing**.
- 4 Locate the **Material Contents** section. In the table, enter the following settings:

Property	Variable	Value	Unit	Property group
Young's modulus	E	7e6 [Pa]	Pa	Young's modulus and Poisson's ratio
Poisson's ratio	nu	0.47	1	Young's modulus and Poisson's ratio
Density	rho	1100 [kg/m^3]	kg/m <sup>3</sup>	Basic

- 5 In the **Materials** toolbar, click  **Add Material** to close the **Add Material** window.

Proceed to setting up the physics. First, add the selections for the two domain physics (acoustics and solid mechanics) and note that the warning in materials node disappears. Then proceed to the detailed physics setup.

### **SOLID MECHANICS (SOLID)**

- 1 In the **Settings** window for **Solid Mechanics**, locate the **Domain Selection** section.
- 2 From the **Selection** list, choose **Solid Domains**.

### **PRESSURE ACOUSTICS, FREQUENCY DOMAIN (ACPR)**

- 1 In the **Model Builder** window, under **Component 1 (comp1)** click **Pressure Acoustics, Frequency Domain (acpr)**.
- 2 In the **Settings** window for **Pressure Acoustics, Frequency Domain**, locate the **Domain Selection** section.
- 3 From the **Selection** list, choose **Air Domains**.

In the **Electrical Circuit** physics, set up the lumped model of the Knowles TEC-30033 receiver by loading its SPICE circuit. Then set up the voltage source driving the receiver and the external coupling to the acoustics, that is, the pressure at the outlet of the miniature loudspeaker.

### **ELECTRICAL CIRCUIT (CIR)**

#### *Subcircuit Definition TEC30033 (TEC30033)*

- 1 In the **Model Builder** window, under **Component 1 (comp1)** right-click **Electrical Circuit (cir)** and choose **Import SPICE Netlist**.
- 2 Browse to the model's Application Libraries folder and double-click the file `lumped_receiver_vibroacoustic_TEC30033.cir`.

#### *Resistor RKARM (RKARM)*

- 1 In the **Model Builder** window, expand the **Subcircuit Definition TEC30033 (TEC30033)** node, then click **Resistor RKARM (RKARM)**.
- 2 In the **Settings** window for **Resistor**, locate the **Device Parameters** section.
- 3 In the  $R$  text field, type `GKarm`.

#### *Subcircuit Definition TEC30033 (TEC30033)*

In the **Model Builder** window, collapse the **Subcircuit Definition TEC30033 (TEC30033)** node.

#### *Subcircuit Instance 1 (X1)*

- 1 In the **Electrical Circuit** toolbar, click  **Subcircuit Instance**.

- 2 In the **Settings** window for **Subcircuit Instance**, locate the **Node Connections** section.
- 3 From the **Subcircuit definition** list, choose **Subcircuit Definition TEC30033 (TEC30033)**.
- 4 In the table, enter the following settings:

Local node names	Node names
P1	p1
N1	0
P2	p2
N2	0

*Voltage Source 1 (V1)*

- 1 In the **Electrical Circuit** toolbar, click  **Voltage Source**.
- 2 In the **Settings** window for **Voltage Source**, locate the **Node Connections** section.
- 3 In the table, enter the following settings:

Label	Node names
p	p1
n	0

- 4 Locate the **Device Parameters** section. In the  $v_{src}$  text field, type V0.

*External I vs. U 1 (IvsU1)*

- 1 In the **Electrical Circuit** toolbar, click  **External I vs. U**.  
Set up the external source that couples to the **Lumped Port** in pressure acoustics.
- 2 In the **Settings** window for **External I vs. U**, locate the **Node Connections** section.
- 3 In the table, enter the following settings:

Label	Node names
p	p2
n	0

Now, set up the **Solid Mechanics** physics. Add damping to the silicone earmold tube (and define its material property) and then proceed to setting up the **Rigid Material** properties. The transducer is modeled through rigid body motion with given center of mass and moment of inertia. The motion and vibration characteristics are given by coupling the lumped spice model to the rigid domain by applying forces and moment.

## SOLID MECHANICS (SOLID)

### *Linear Elastic Material 1*

In the **Model Builder** window, under **Component 1 (comp1) > Solid Mechanics (solid)** click **Linear Elastic Material 1**.

### *Damping 1*

- 1 In the **Physics** toolbar, click  **Attributes** and choose **Damping**.
- 2 In the **Settings** window for **Damping**, locate the **Damping Settings** section.
- 3 From the **Damping type** list, choose **Isotropic loss factor**.

## MATERIALS

### *Tubing (Silicone) (mat2)*

- 1 In the **Model Builder** window, under **Component 1 (comp1) > Materials** click **Tubing (Silicone) (mat2)**.
- 2 In the **Settings** window for **Material**, locate the **Material Contents** section.
- 3 In the table, enter the following settings:

Property	Variable	Value	Unit	Property group
Isotropic structural loss factor	eta_s	0.1		Basic

## SOLID MECHANICS (SOLID)

### *Rigid Material 1*

- 1 In the **Physics** toolbar, click  **Domains** and choose **Rigid Material**.
- 2 In the **Settings** window for **Rigid Material**, locate the **Domain Selection** section.
- 3 From the **Selection** list, choose **Transducer**.
- 4 Locate the **Density** section. From the  $\rho$  list, choose **User defined**. Locate the **Center of Rotation** section. From the list, choose **User defined**.
- 5 Specify the  $\mathbf{X}_c$  vector as

CMx	x
CMy	y
CMz	z

### *Mass and Moment of Inertia 1*

- 1 In the **Physics** toolbar, click  **Attributes** and choose **Mass and Moment of Inertia**.

- 2 In the **Settings** window for **Mass and Moment of Inertia**, locate the **Coordinate System Selection** section.
- 3 From the **Coordinate system** list, choose **Base Vector System 2 (sys2)**.
- 4 Locate the **Center of Mass** section. From the list, choose **User defined**.
- 5 Specify the  $\mathbf{X}_m$  vector as

CMx	x
CMy	y
CMz	z

- 6 Locate the **Mass and Moment of Inertia** section. In the  $m$  text field, type **Mass**.
- 7 From the list, choose **Symmetric**.
- 8 Specify the **I** matrix as

Ixx	Ixy	Ixz
Ixy	Iyy	Iyz
Ixz	Iyz	Izz

#### *Rigid Material 1*

In the **Model Builder** window, click **Rigid Material 1**.

#### *Applied Force 1*

- 1 In the **Physics** toolbar, click  **Attributes** and choose **Applied Force**.
- 2 In the **Settings** window for **Applied Force**, locate the **Coordinate System Selection** section.
- 3 From the **Coordinate system** list, choose **Base Vector System 2 (sys2)**.
- 4 Locate the **Location** section. From the list, choose **User defined**.
- 5 Specify the  $\mathbf{X}_p$  vector as

CMx	x
CMy	y
CMz	z

- 6 Locate the **Applied Force** section. Specify the  $\mathbf{F}$  vector as

Fx	x1
0	x2
Fz	x3

### *Rigid Material 1*

In the **Model Builder** window, click **Rigid Material 1**.

### *Applied Moment 1*

- 1 In the **Physics** toolbar, click  **Attributes** and choose **Applied Moment**.
- 2 In the **Settings** window for **Applied Moment**, locate the **Coordinate System Selection** section.
- 3 From the **Coordinate system** list, choose **Base Vector System 2 (sys2)**.
- 4 Locate the **Applied Moment** section. Specify the **M** vector as

0	x1
My	x2
0	x3

### *Fixed Constraint 1*

- 1 In the **Physics** toolbar, click  **Boundaries** and choose **Fixed Constraint**.
- 2 Select Boundaries 55, 56, 60, and 63 only.

Set up the acoustics model. The **Narrow Region Acoustics** feature is used to model the thermoviscous losses in the narrow earmold tube. A simple RCL impedance condition could have been used to model the mechanical properties of the microphone located at the end of the 2 cc coupler. This is omitted here and the microphone is assumed rigid.

## **PRESSURE ACOUSTICS, FREQUENCY DOMAIN (ACPR)**

In the **Model Builder** window, under **Component 1 (comp1)** click **Pressure Acoustics, Frequency Domain (acpr)**.

### *Lumped Port 1*

- 1 In the **Physics** toolbar, click  **Boundaries** and choose **Lumped Port**.  
The **Lumped Port** has built-in functionality that couples the port boundary to the Electrical Circuit physics.
- 2 Select Boundary 34 only.
- 3 In the **Settings** window for **Lumped Port**, locate the **Lumped Port Properties** section.
- 4 From the **Connection type** list, choose **Circuit**.  
Now, finalize the coupling between the port and the circuit.

## ELECTRICAL CIRCUIT (CIR)

*External I vs. U I (IvsUI)*

- 1 In the **Model Builder** window, under **Component 1 (comp1) > Electrical Circuit (cir)** click **External I vs. U I (IvsUI)**.
- 2 In the **Settings** window for **External I vs. U**, locate the **External Device** section.
- 3 From the  $V$  list, choose **Voltage from lumped port (acpr/lport1)**.

## PRESSURE ACOUSTICS, FREQUENCY DOMAIN (ACPR)

In the **Model Builder** window, under **Component 1 (comp1)** click **Pressure Acoustics, Frequency Domain (acpr)**.

*Narrow Region Acoustics I*

- 1 In the **Physics** toolbar, click  **Domains** and choose **Narrow Region Acoustics**.
- 2 In the **Settings** window for **Narrow Region Acoustics**, locate the **Domain Selection** section.
- 3 From the **Selection** list, choose **Inner Tube**.
- 4 Locate the **Duct Properties** section. From the **Duct type** list, choose **Circular duct**.
- 5 In the  $a$  text field, type  $Td/2$ .

Finally, set up the multiphysics coupling between acoustics and structure. Then proceed to meshing.

## MULTIPHYSICS

*Acoustic–Structure Boundary I (asbl)*

- 1 In the **Physics** toolbar, click  **Multiphysics Couplings** and choose **Boundary > Acoustic–Structure Boundary**.
- 2 In the **Settings** window for **Acoustic–Structure Boundary**, locate the **Boundary Selection** section.
- 3 From the **Selection** list, choose **Acoustic-Structure Interaction**.

## MESH I

In this model, the mesh is set up manually. Proceed by directly adding the desired mesh components. Use a swept mesh through the solids to make sure that there are at least elements through the thickness. This is done to make sure that the bending stiffness is correctly captured.

*Mapped I*

- 1 In the **Mesh** toolbar, click  **More Generators** and choose **Mapped**.

2 Select Boundaries 10, 11, 17, 20, and 24 only.

#### *Distribution 1*

1 Right-click **Mapped 1** and choose **Distribution**.

2 Select Edges 24, 32, and 33 only.

3 In the **Settings** window for **Distribution**, locate the **Distribution** section.

4 In the **Number of elements** text field, type 3.

#### *Size*

1 In the **Model Builder** window, under **Component 1 (comp1) > Mesh 1** click **Size**.

2 In the **Settings** window for **Size**, locate the **Element Size** section.

3 Click the **Custom** button.

4 Locate the **Element Size Parameters** section. In the **Maximum element size** text field, type  $2 \cdot Td$ .

5 In the **Minimum element size** text field, type  $Td/2$ .

#### *Swept 1*

1 In the **Mesh** toolbar, click  **Swept**.

2 In the **Settings** window for **Swept**, locate the **Domain Selection** section.

3 From the **Geometric entity level** list, choose **Domain**.

4 Select Domains 2–12 and 14–19 only.

#### *Size 1*

1 Right-click **Swept 1** and choose **Size**.

2 In the **Settings** window for **Size**, locate the **Element Size** section.

3 Click the **Custom** button.

4 Locate the **Element Size Parameters** section.

5 Select the **Maximum element size** checkbox. In the associated text field, type  $Td/2$ .

#### *Free Tetrahedral 1*

1 In the **Mesh** toolbar, click  **Free Tetrahedral**.

2 In the **Model Builder** window, right-click **Mesh 1** and choose **Build All**.

The mesh should look like this.

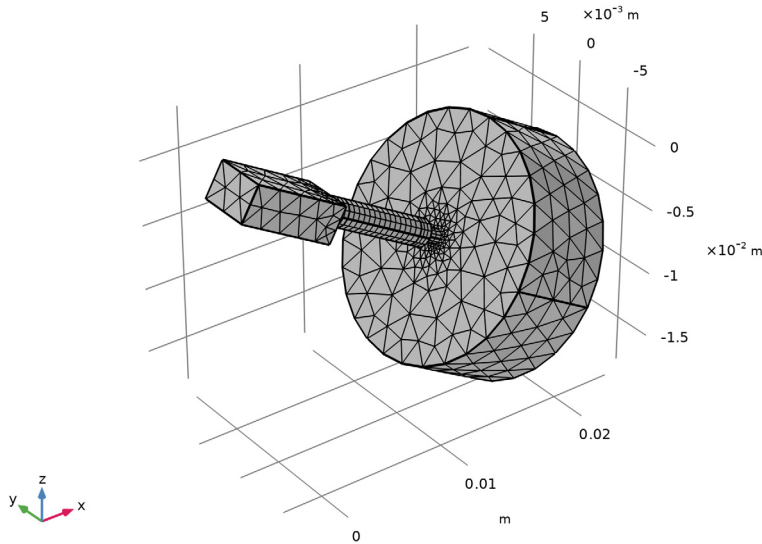

## STUDY 1

### Step 1: Frequency Domain

Some manual setup of the solver is necessary. The default for the current combination of physics is to use a segregated solution approach. In this model, it is necessary to use a fully coupled solver. Generate the default solver and then make a small change. The model is solved from 10 Hz to 10 kHz in steps of 1/12 octaves.

- 1 In the **Model Builder** window, under **Study 1** click **Step 1: Frequency Domain**.
- 2 In the **Settings** window for **Frequency Domain**, locate the **Study Settings** section.
- 3 Click  **Range**.
- 4 In the **Range** dialog, choose **ISO preferred frequencies** from the **Entry method** list.
- 5 In the **Start frequency** text field, type 10.
- 6 In the **Stop frequency** text field, type fmax.
- 7 From the **Interval** list, choose **1/12 octave**.
- 8 Click **Replace**.

9 In the **Study** toolbar, click  **Compute**.

## RESULTS

### *Displacement (solid)*

Proceed to postprocessing the results. First, use the default plots and make some modifications to generate [Figure 10](#), [Figure 11](#), and [Figure 12](#). If you zoom in on the **Sound Pressure Level (acpr)** plot you can see the location of the geometric center and the center of mass (added using the **Annotation** option). They are located close together. Change the frequency parameter to look at the solution for one of the solved frequencies.

Secondly, proceed to plotting the acoustic and vibration response and compare it with measurement data. This will recreate [Figure 6](#), [Figure 7](#), [Figure 8](#), and [Figure 9](#). The measurement data is imported as interpolation functions under the **Definitions** node.

1 In the **Settings** window for **3D Plot Group**, type **Displacement (solid)** in the **Label** text field.

### *Volume 1*

1 In the **Model Builder** window, expand the **Displacement (solid)** node, then click **Volume 1**.

2 In the **Settings** window for **Volume**, locate the **Expression** section.

3 In the **Expression** text field, type `solid.disp`.

4 In the **Displacement (solid)** toolbar, click  **Plot**.

### *Sound Pressure Level (acpr)*

1 In the **Model Builder** window, under **Results** click **Sound Pressure Level (acpr)**.

2 In the **Sound Pressure Level (acpr)** toolbar, click  **Plot**.

### *Annotation 1*

1 Right-click **Sound Pressure Level (acpr)** and choose **Annotation**.

2 In the **Settings** window for **Annotation**, locate the **Annotation** section.

3 In the **Text** text field, type `Center of mass`.

4 Locate the **Position** section. In the **x** text field, type `CMx`.

5 In the **y** text field, type `CMy`.

6 In the **z** text field, type `CMz`.

### *Annotation 2*

1 Right-click **Sound Pressure Level (acpr)** and choose **Annotation**.

2 In the **Settings** window for **Annotation**, locate the **Annotation** section.

- 3 In the **Text** text field, type Geometric center of box.
- 4 Locate the **Position** section. In the **x** text field, type mass1.CMX.
- 5 In the **y** text field, type mass1.CMY.
- 6 In the **z** text field, type mass1.CMZ.
- 7 Locate the **Coloring and Style** section. From the **Color** list, choose **Red**.
- 8 From the **Anchor point** list, choose **Lower left**.
- 9 In the **Sound Pressure Level (acpr)** toolbar, click  **Plot**.



#### *Isosurface 1*

- 1 In the **Model Builder** window, expand the **Acoustic Pressure, Isosurfaces (acpr)** node, then click **Isosurface 1**.
- 2 In the **Settings** window for **Isosurface**, locate the **Levels** section.
- 3 In the **Total levels** text field, type 20.

#### *Acoustic Pressure, Isosurfaces (acpr)*



- 1 In the **Model Builder** window, click **Acoustic Pressure, Isosurfaces (acpr)**.
- 2 In the **Settings** window for **3D Plot Group**, click to expand the **Title** section.
- 3 From the **Title type** list, choose **Label**.

#### *Coordinate System Volume 1*



- 1 In the **Acoustic Pressure, Isosurfaces (acpr)** toolbar, click  **More Plots** and choose **Coordinate System Volume**.
- 2 In the **Settings** window for **Coordinate System Volume**, locate the **Coordinate System** section.
- 3 From the **Coordinate system** list, choose **Base Vector System 2 (sys2)**.
- 4 Locate the **Positioning** section. Find the **x grid points** subsection. From the **Entry method** list, choose **Coordinates**.
- 5 In the **Coordinates** text field, type CMX.
- 6 Find the **y grid points** subsection. From the **Entry method** list, choose **Coordinates**.
- 7 In the **Coordinates** text field, type CMY.
- 8 Find the **z grid points** subsection. From the **Entry method** list, choose **Coordinates**.
- 9 In the **Coordinates** text field, type CMZ.
- 10 In the **Acoustic Pressure, Isosurfaces (acpr)** toolbar, click  **Plot**.

## GLOBAL DEFINITIONS

### *Interpolation 1 (int1)*

- 1 In the **Home** toolbar, click  **Functions** and choose **Global > Interpolation**.
- 2 In the **Settings** window for **Interpolation**, locate the **Definition** section.
- 3 From the **Data source** list, choose **File**.
- 4 Click  **Browse**.
- 5 Browse to the model's Application Libraries folder and double-click the file `lumped_receiver_vibroacoustic_SPL_data.txt`.
- 6 Click  **Import**.
- 7 Locate the **Data Column Settings** section. In the table, click to select the cell at row number 2 and column number 1.
- 8 In the **Name** text field, type `SPL_data`.



### *Interpolation 2 (int2)*

- 1 In the **Home** toolbar, click  **Functions** and choose **Global > Interpolation**.
- 2 In the **Settings** window for **Interpolation**, locate the **Definition** section.
- 3 From the **Data source** list, choose **File**.
- 4 Click  **Browse**.
- 5 Browse to the model's Application Libraries folder and double-click the file `lumped_receiver_vibroacoustic_xvel_data_01.txt`.
- 6 Click  **Import**.
- 7 Locate the **Data Column Settings** section. In the table, enter the following settings:

Columns	Type	Settings
Column 2	Function values	Function name=xvel_real_01



- 8 In the **Name** text field, type `xvel_real_01`.
- 9 In the table, click to select the cell at row number 3 and column number 2.
- 10 In the **Name** text field, type `xvel_imag_01`.

### *Interpolation 3 (int3)*

- 1 In the **Home** toolbar, click  **Functions** and choose **Global > Interpolation**.
- 2 In the **Settings** window for **Interpolation**, locate the **Definition** section.
- 3 From the **Data source** list, choose **File**.
- 4 Click  **Browse**.

- 5 Browse to the model's Application Libraries folder and double-click the file `lumped_receiver_vibroacoustic_xvel_data_02.txt`.
- 6 Click  **Import**.
- 7 In the **Function name** text field, type `xvel_dB_02`.



*Interpolation 4 (int4)*

- 1 In the **Home** toolbar, click  **Functions** and choose **Global > Interpolation**.
- 2 In the **Settings** window for **Interpolation**, locate the **Definition** section.
- 3 From the **Data source** list, choose **File**.
- 4 Click  **Browse**.
- 5 Browse to the model's Application Libraries folder and double-click the file `lumped_receiver_vibroacoustic_zvel_data_01.txt`.
- 6 Click  **Import**.
- 7 Locate the **Data Column Settings** section. In the table, enter the following settings:

Columns	Type	Settings
Column 2	Function values	Function name=zvel_real_01

- 8 In the **Name** text field, type `zvel_real_01`.
- 9 In the table, click to select the cell at row number 3 and column number 2.
- 10 In the **Name** text field, type `zvel_imag_01`.

*Interpolation 5 (int5)*

- 1 In the **Home** toolbar, click  **Functions** and choose **Global > Interpolation**.
- 2 In the **Settings** window for **Interpolation**, locate the **Definition** section.
- 3 From the **Data source** list, choose **File**.
- 4 Click  **Browse**.
- 5 Browse to the model's Application Libraries folder and double-click the file `lumped_receiver_vibroacoustic_zvel_data_02.txt`.
- 6 Click  **Import**.
- 7 In the **Function name** text field, type `zvel_dB_02`.

**RESULTS**

*Grid ID 1*

- 1 In the **Results** toolbar, click  **More Datasets** and choose **Grid > Grid ID**.

- 2 In the **Settings** window for **Grid ID**, locate the **Data** section.
- 3 From the **Source** list, choose **Function**.
- 4 From the **Function** list, choose **All**.
- 5 Locate the **Parameter Bounds** section. In the **Name** text field, type  $f$ .
- 6 In the **Minimum** text field, type 100.
- 7 In the **Maximum** text field, type 10000.

#### *SPL at Microphone*

- 1 In the **Results** toolbar, click  **ID Plot Group**.
- 2 In the **Settings** window for **ID Plot Group**, type *SPL at Microphone* in the **Label** text field.
- 3 Click to expand the **Title** section. From the **Title type** list, choose **Label**.
- 4 Locate the **Plot Settings** section.
- 5 Select the **y-axis label** checkbox. In the associated text field, type *Level (dB SPL)*.
- 6 Locate the **Axis** section. Select the **x-axis log scale** checkbox.
- 7 Locate the **Legend** section. From the **Position** list, choose **Lower left**.

#### *Global I*

- 1 Right-click **SPL at Microphone** and choose **Global**.
- 2 In the **Settings** window for **Global**, locate the **y-Axis Data** section.
- 3 In the table, enter the following settings:

Expression	Unit	Description
$20 \cdot \log_{10}(\text{abs}(\text{pmic}/V0/\text{acpr.pref\_SPL}))$		Simulation

#### *Line Graph I*

- 1 In the **Model Builder** window, right-click **SPL at Microphone** and choose **Line Graph**.
- 2 In the **Settings** window for **Line Graph**, locate the **Data** section.
- 3 From the **Dataset** list, choose **Grid ID I**.
- 4 Locate the **y-Axis Data** section. In the **Expression** text field, type  $\text{SPL\_data}(f)$ .
- 5 Locate the **x-Axis Data** section. From the **Parameter** list, choose **Expression**.
- 6 In the **Expression** text field, type  $f[\text{Hz}/\text{m}]$ .
- 7 Select the **Description** checkbox. In the associated text field, type *freq*.
- 8 Click to expand the **Legends** section. Select the **Show legends** checkbox.
- 9 From the **Legends** list, choose **Manual**.

10 In the table, enter the following settings:

---

**Legends**

---

**Measurements**

---

11 In the **SPL at Microphone** toolbar, click  **Plot**.

*x-Velocity*

- 1 In the **Results** toolbar, click  **ID Plot Group**.
- 2 In the **Settings** window for **ID Plot Group**, type *x-Velocity* in the **Label** text field.
- 3 Locate the **Title** section. From the **Title type** list, choose **Label**.
- 4 Locate the **Plot Settings** section.
- 5 Select the **y-axis label** checkbox. In the associated text field, type *x-velocity (dB rel. 1 m/s/V)*.
- 6 Locate the **Axis** section. Select the **x-axis log scale** checkbox.
- 7 Locate the **Legend** section. From the **Position** list, choose **Lower right**.

*Point Graph 1*

- 1 Right-click **x-Velocity** and choose **Point Graph**.
- 2 Select Points 1 and 17 only.
- 3 In the **Settings** window for **Point Graph**, locate the **y-Axis Data** section.
- 4 In the **Expression** text field, type  $20 \cdot \log_{10}(\text{abs}(v_{x\_local})/V_0)$ .
- 5 Click to expand the **Legends** section. Select the **Show legends** checkbox.
- 6 Find the **Prefix and suffix** subsection. In the **Prefix** text field, type *Point*.
- 7 In the **Suffix** text field, type *, Simulation*.

*Line Graph 1*

- 1 In the **Model Builder** window, right-click **x-Velocity** and choose **Line Graph**.
- 2 In the **Settings** window for **Line Graph**, locate the **Data** section.
- 3 From the **Dataset** list, choose **Grid ID 1**.
- 4 Locate the **y-Axis Data** section. In the **Expression** text field, type  $20 \cdot \log_{10}(\sqrt{(x_{vel\_real\_01}(f))^2 + x_{vel\_imag\_01}(f)^2})$ .
- 5 Locate the **x-Axis Data** section. From the **Parameter** list, choose **Expression**.
- 6 In the **Expression** text field, type  $f$  [Hz/m].
- 7 Select the **Description** checkbox. In the associated text field, type *freq*.
- 8 Locate the **Legends** section. Select the **Show legends** checkbox.

9 From the **Legends** list, choose **Manual**.

10 In the table, enter the following settings:

---

<b>Legends</b>
Measurements (series 1)

---

#### *Line Graph 2*

1 Right-click **Line Graph 1** and choose **Duplicate**.

2 In the **Settings** window for **Line Graph**, locate the **y-Axis Data** section.

3 In the **Expression** text field, type `xve1_dB_02(f)`.

4 Locate the **Legends** section. In the table, enter the following settings:

---

<b>Legends</b>
Measurements (series 2)

---

5 In the **x-Velocity** toolbar, click  **Plot**.

#### *y-Velocity*

1 In the **Results** toolbar, click  **ID Plot Group**.

2 In the **Settings** window for **ID Plot Group**, type *y-Velocity* in the **Label** text field.

3 Locate the **Title** section. From the **Title type** list, choose **Label**.

4 Locate the **Plot Settings** section.

5 Select the **y-axis label** checkbox. In the associated text field, type *y-velocity (dB rel. 1 m/s/V)*.

6 Locate the **Axis** section. Select the **x-axis log scale** checkbox.

#### *Point Graph 1*

1 Right-click **y-Velocity** and choose **Point Graph**.

2 Select Point 2 only.

3 In the **Settings** window for **Point Graph**, locate the **y-Axis Data** section.

4 In the **Expression** text field, type `20*log10(abs(vy_local)/V0)`.

5 In the **y-Velocity** toolbar, click  **Plot**.

#### *z-Velocity*

1 In the **Results** toolbar, click  **ID Plot Group**.

2 In the **Settings** window for **ID Plot Group**, type *z-Velocity* in the **Label** text field.

3 Locate the **Title** section. From the **Title type** list, choose **Label**.

- 4 Locate the **Plot Settings** section.
- 5 Select the **y-axis label** checkbox. In the associated text field, type  $z\text{-velocity (dB rel. 1 m/s/V)}$ .
- 6 Locate the **Axis** section. Select the **x-axis log scale** checkbox.
- 7 Locate the **Legend** section. From the **Position** list, choose **Lower right**.

#### *Point Graph 1*

- 1 Right-click **z-Velocity** and choose **Point Graph**.
- 2 Select Points 1 and 17 only.
- 3 In the **Settings** window for **Point Graph**, locate the **y-Axis Data** section.
- 4 In the **Expression** text field, type  $20*\log_{10}(\text{abs}(vz\_local)/V0)$ .
- 5 Locate the **Legends** section. Select the **Show legends** checkbox.
- 6 Find the **Prefix and suffix** subsection. In the **Prefix** text field, type **Point**.
- 7 In the **Suffix** text field, type **, Simulation**.

#### *Line Graph 1*

- 1 In the **Model Builder** window, right-click **z-Velocity** and choose **Line Graph**.
- 2 In the **Settings** window for **Line Graph**, locate the **Data** section.
- 3 From the **Dataset** list, choose **Grid ID 1**.
- 4 Locate the **y-Axis Data** section. In the **Expression** text field, type  $20*\log_{10}(\text{sqrt}(zvel\_real\_01(f)^2+zvel\_imag\_01(f)^2))$ .
- 5 Locate the **x-Axis Data** section. From the **Parameter** list, choose **Expression**.
- 6 In the **Expression** text field, type  $f[\text{Hz/m}]$ .
- 7 Select the **Description** checkbox. In the associated text field, type **freq**.
- 8 Locate the **Legends** section. Select the **Show legends** checkbox.
- 9 From the **Legends** list, choose **Manual**.
- 10 In the table, enter the following settings:

<b>Legends</b>
Measurements (series 1)

#### *Line Graph 2*

- 1 Right-click **Line Graph 1** and choose **Duplicate**.
- 2 In the **Settings** window for **Line Graph**, locate the **y-Axis Data** section.
- 3 In the **Expression** text field, type  $zvel\_dB\_02(f)$ .

4 Locate the **Legends** section. In the table, enter the following settings:

---

<b>Legends</b>
Measurements (series 2)

---

5 In the **z-Velocity** toolbar, click  **Plot**.

## *Geometry Modeling Instructions*

---

From the **File** menu, choose **New**.

### **NEW**

In the **New** window, click  **Blank Model**.

### **GLOBAL DEFINITIONS**

#### *Parameters 1*

- 1 In the **Model Builder** window, under **Global Definitions** click **Parameters 1**.
- 2 In the **Settings** window for **Parameters**, locate the **Parameters** section.
- 3 Click  **Load from File**.
- 4 Browse to the model's Application Libraries folder and double-click the file `lumped_receiver_vibroacoustic_geom_sequence_parameters.txt`.

### **ADD COMPONENT**

In the **Home** toolbar, click  **Add Component** and choose **3D**.

### **GEOMETRY 1**

#### *Block 1 (blk1)*

- 1 In the **Geometry** toolbar, click  **Block**.
- 2 In the **Settings** window for **Block**, locate the **Size and Shape** section.
- 3 In the **Width** text field, type Lx.
- 4 In the **Depth** text field, type Ly.
- 5 In the **Height** text field, type Lz.
- 6 Locate the **Position** section. From the **Base** list, choose **Center**.

#### *Cylinder 1 (cyl1)*

- 1 In the **Geometry** toolbar, click  **Cylinder**.

- 2 In the **Settings** window for **Cylinder**, locate the **Size and Shape** section.
- 3 In the **Radius** text field, type  $Td/2$ .
- 4 In the **Height** text field, type  $TL$ .
- 5 Locate the **Position** section. In the **x** text field, type  $Lx/2$ .
- 6 In the **z** text field, type  $Th$ .
- 7 Locate the **Axis** section. From the **Axis type** list, choose **x-axis**.

*Cylinder 2 (cyl2)*

- 1 In the **Geometry** toolbar, click  **Cylinder**.
- 2 In the **Settings** window for **Cylinder**, locate the **Size and Shape** section.
- 3 In the **Radius** text field, type  $Td/2+Ttube$ .
- 4 In the **Height** text field, type  $Ltube$ .
- 5 Locate the **Position** section. In the **x** text field, type  $Lx/2+SToffset$ .
- 6 In the **z** text field, type  $Th$ .
- 7 Locate the **Axis** section. From the **Axis type** list, choose **x-axis**.
- 8 Click to expand the **Layers** section. In the table, enter the following settings:

Layer name	Thickness (m)
Layer 1	$Ttube$

*Cylinder 3 (cyl3)*



- 1 In the **Geometry** toolbar, click  **Cylinder**.
- 2 In the **Settings** window for **Cylinder**, locate the **Size and Shape** section.
- 3 In the **Radius** text field, type  $Td/2$ .
- 4 In the **Height** text field, type  $LtubeC$ .
- 5 Locate the **Position** section. In the **x** text field, type  $Lx/2+SToffset+Ltube - (LtubeC - CToffset)$ .
- 6 In the **z** text field, type  $Th$ .
- 7 Locate the **Axis** section. From the **Axis type** list, choose **x-axis**.

*Cylinder 4 (cyl4)*

- 1 In the **Geometry** toolbar, click  **Cylinder**.
- 2 In the **Settings** window for **Cylinder**, locate the **Size and Shape** section.
- 3 In the **Radius** text field, type  $d_{2cc}/2$ .
- 4 In the **Height** text field, type  $L_{2cc}$ .

- 5 Locate the **Position** section. In the **x** text field, type  $Lx/2+SToffset+Ltube+CToffset$ .
- 6 In the **z** text field, type  $Th$ .
- 7 Locate the **Axis** section. From the **Axis type** list, choose **x-axis**.



#### *Work Plane 1 (wp1)*

- 1 In the **Geometry** toolbar, click  **Work Plane**.
- 2 In the **Settings** window for **Work Plane**, locate the **Plane Definition** section.
- 3 From the **Plane type** list, choose **Face parallel**.
- 4 Click the  **Wireframe Rendering** button in the **Graphics** toolbar.
- 5 On the object **cyl1**, select Boundary 4 only.



#### *Work Plane 2 (wp2)*

- 1 In the **Geometry** toolbar, click  **Work Plane**.
- 2 In the **Settings** window for **Work Plane**, locate the **Plane Definition** section.
- 3 From the **Plane type** list, choose **Face parallel**.
- 4 On the object **cyl3**, select Boundary 3 only.

#### *Partition Objects 1 (par1)*

- 1 In the **Geometry** toolbar, click  **Booleans and Partitions** and choose **Partition Objects**.
- 2 Select the object **cyl2** only.
- 3 In the **Settings** window for **Partition Objects**, locate the **Partition Objects** section.
- 4 From the **Partition with** list, choose **Work plane**.
- 5 From the **Work plane** list, choose **Work Plane 1 (wp1)**.
- 6 Click  **Build Selected**.

#### *Partition Objects 2 (par2)*



- 1 In the **Geometry** toolbar, click  **Booleans and Partitions** and choose **Partition Objects**.
- 2 Select the object **par1** only.
- 3 In the **Settings** window for **Partition Objects**, locate the **Partition Objects** section.
- 4 From the **Partition with** list, choose **Work plane**.
- 5 Click  **Build Selected**.

#### *Move 1 (mov1)*

- 1 In the **Geometry** toolbar, click  **Transforms** and choose **Move**.
- 2 Click in the **Graphics** window and then press Ctrl+A to select all objects.
- 3 In the **Settings** window for **Move**, locate the **Displacement** section.

- 4 In the **x** text field, type 1 [mm].
- 5 In the **y** text field, type 1 [mm].
- 6 Click  **Build Selected**.

*Rotate l (rotl)*

- 1 In the **Geometry** toolbar, click  **Transforms** and choose **Rotate**.
- 2 Click in the **Graphics** window and then press Ctrl+A to select all objects.
- 3 In the **Settings** window for **Rotate**, locate the **Rotation** section.
- 4 In the **Angle** text field, type 30.
- 5 Locate the **Point on Axis of Rotation** section. In the **x** text field, type 1 [mm].
- 6 In the **y** text field, type 1 [mm].
- 7 Locate the **Rotation** section. From the **Axis type** list, choose **y-axis**.
- 8 Click  **Build All Objects**.

*Form Union (fin)*

- 1 In the **Geometry** toolbar, click  **Build All**.
- 2 Click the  **Zoom Extents** button in the **Graphics** toolbar.

The finalized geometry should look like the figure below.

3 In the **Model Builder** window, click **Form Union (fin)**.

