



Model created in COMSOL Multiphysics 6.4

Lumped Receiver Connected to Test Setup with a 0.4-cc Coupler

Introduction

When simulations are involved in the development of mobile devices, consumer electronics, hearing aids, or headsets, it is necessary to consider how the transducers interact with the rest of the system. For some tasks, such as analyzing the vibration isolation of an elastic mounting of the transducer, it may be necessary to include a fully detailed multiphysics model of the transducer itself. In applications where only the electroacoustic response of the device is of interest, a lumped parameter model of the transducer (an electroacoustic analogy as would be implemented in Spice) can be coupled with a multiphysics model of the rest of the system.

In this example a Knowles ED-23146 balanced armature receiver (miniature loudspeaker) is connected to a test setup consisting of a 50 mm (1 mm ID) tube into a generic 0.4-cc measurement coupler.¹ This test setup represents the receiver in a behind-the-ear hearing aid driving an ear canal with a deeply inserted ear mold via a long narrow tube. Data collected when using the 0.4-cc coupler will give a more realistic assessment of acoustic data for deeply inserted devices compared to using the 711 coupler (see [Ref. 1](#)). The model shows how to connect a receiver modeled as a lumped Spice network to the acoustic system of the tube and a measurement coupler modeled in the finite element domain. The response at the measurement microphone in the coupler as well as the electric input impedance to the receiver are compared with measurements. The losses in the long narrow tube are in this model included using one of the equivalent fluid models of the Narrow Region Acoustics feature in the Pressure Acoustics, Frequency Domain interface.

Model Definition

A sketch of the measurement set-up analyzed in this model is depicted in [Figure 1](#). It consists of the Knowles ED-23146 receiver which is modeled as an electric Spice circuit using the Electrical Circuit interface. The tube has a length of 50 mm and a diameter of 1 mm and the 0.4-cc coupler is here simply represented by a cylinder with a volume close to 0.4 cm³ (and a small intrusion at one end representing the microphone location). Real

1. This model was created based upon data provided by Knowles, IL, USA.

measurement couplers have more complex geometries. The acoustics inside the tube and the coupler are modeled using the Pressure Acoustics, Frequency Domain interface.

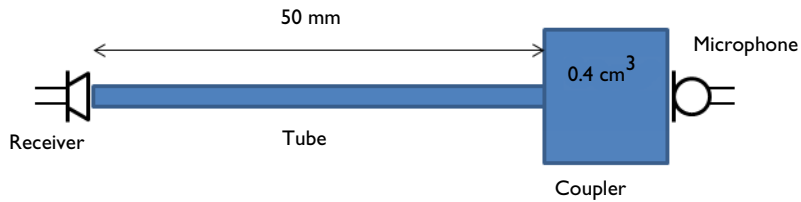

Figure 1: Schematic representation of the modeled system consisting of receiver, tube, coupler, and measurement microphone. The blue domains are modeled using finite elements.

The actual receiver is depicted in [Figure 2](#). It is of the balanced armature type. Knowles provides lumped models for all their transducers enabling engineers to model the devices where they are used.

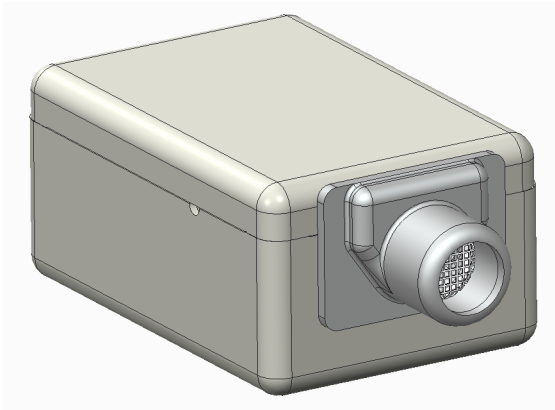

Figure 2: Rendering of the Knowles ED-23146 balanced armature receiver. The device is roughly 4 mm wide, 6 mm deep, and 3 mm high. Image credit: Knowles, IL, USA.

In the Spice network used for the Knowles ED-23146 receiver, the current at the output corresponds to a volume flow (m^3/s) and voltage over the output terminals corresponds to the pressure (Pa), as measured at the outlet of the transducer. See [Ref. 2](#) and [Ref. 3](#) for further details. The coupling between the lumped electric network and the finite element domain is made using the built-in **Circuit** connection option in the **Lumped Port** feature. In this way, there is a bidirectional coupling between the finite element domain and the Spice network.

At the boundary where the measurement microphone is normally located in the coupler, a normal impedance condition has been added to account for the compliance of the microphone diaphragm. In this model, the compliance C_{mic} is equivalent to a volume of 6 mm^3 . The acoustic mass L_{mic} and resistance R_{mic} of the diaphragm are set to typical values. The impedance is given by a simple RCL model

$$Z = \frac{1}{i\omega C_{\text{mic}}} + R_{\text{mic}} + i\omega L_{\text{mic}}. \quad (1)$$

This is implemented by applying the built-in RCL option found in the impedance boundary condition.

Results and Discussion

The response, as measured at the location of the microphone, is depicted in [Figure 3](#). The model results are compared with measurements performed on an actual system and with results obtained without the viscous and thermal acoustics losses. The measurements are seen to agree well with the full model results. At high frequencies (above 14 kHz), the results start not to match well. Here, the wavelength becomes comparable to length scales of structures in the coupler (a quarter wavelength is 0.6 cm) that are not included in this simple cylinder representation, for example, the protective mesh of the microphone. In addition, of course, the lumped parameter model of the receiver is inexact at these high frequencies. Note that the model curves where no acoustic losses are added still show signs of damping. This is due to the losses included in the Spice model of the transducer.

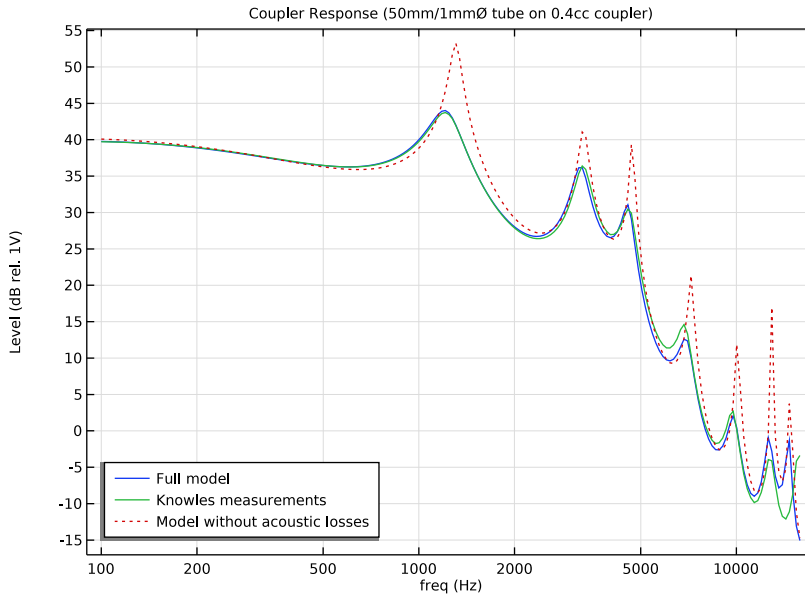

Figure 3: The microphone response comparing the model including the thermal and viscous losses via the narrow region acoustics feature (blue curve), the model without acoustic losses (red dotted curve), and measurements (green curve). Measurement data provided by Knowles, IL, USA.

The frequency dependency of the electric input impedance (real and imaginary part) of the transducer are depicted in Figure 4. The results are compared with measurements and show good agreement.

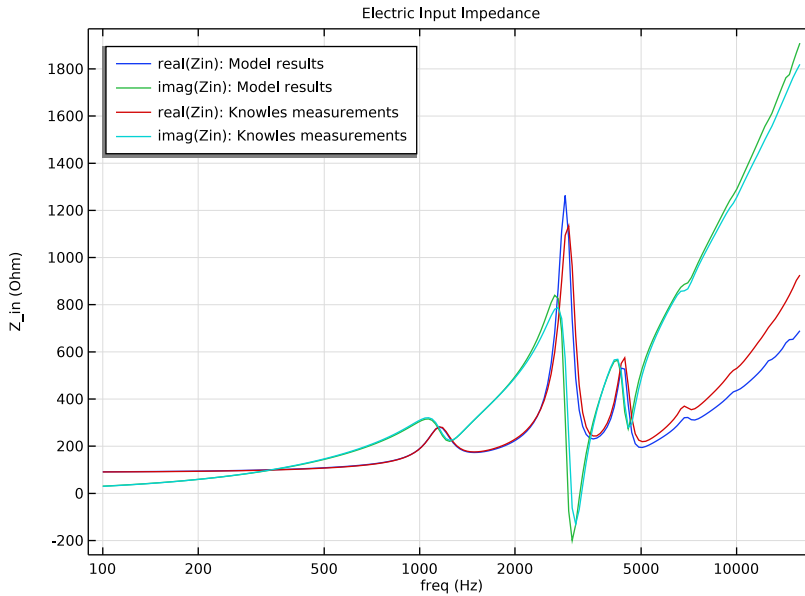

Figure 4: The electric input impedance (real and imaginary part) as a function of the frequency comparing model results (blue and green curves) and measurements (red and cyan curves). Measurements data provided by Knowles, IL, USA.

In Figure 5 and Figure 6, the pressure and sound pressure level distribution inside the tube and coupler system are depicted at three different frequencies (around 1200, 3200, and 4600 Hz). The evaluated frequencies correspond to the three first peaks in the response. They correspond to the quarter, half, and three quarter wave resonances of the tube-coupler system, respectively.

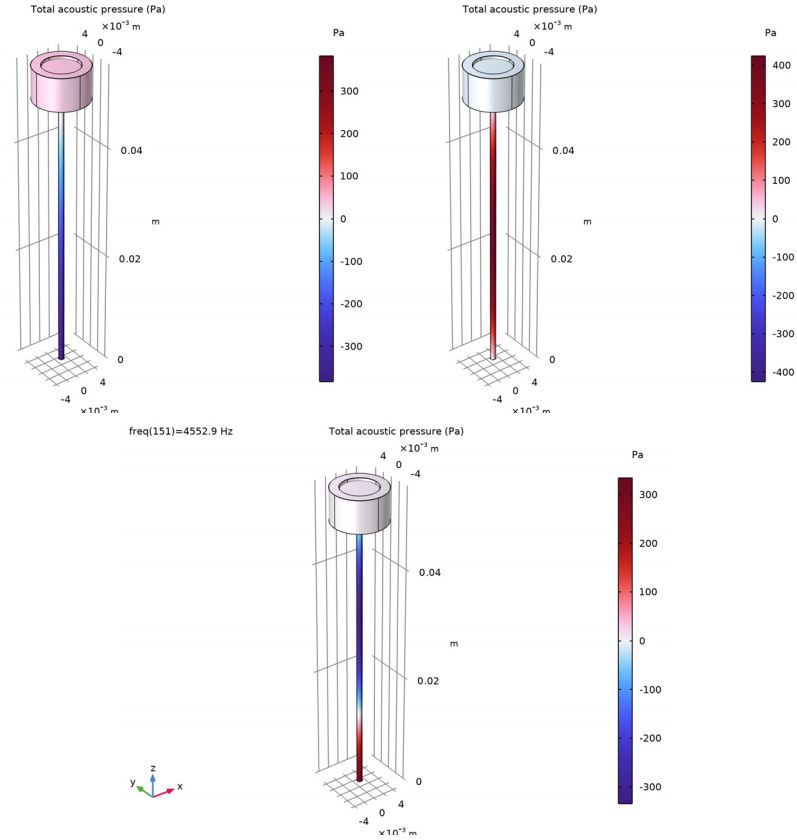

Figure 5: Pressure distribution (real part of the pressure) at frequencies close to $f = 1200$, 3200 , and 4600 Hz.

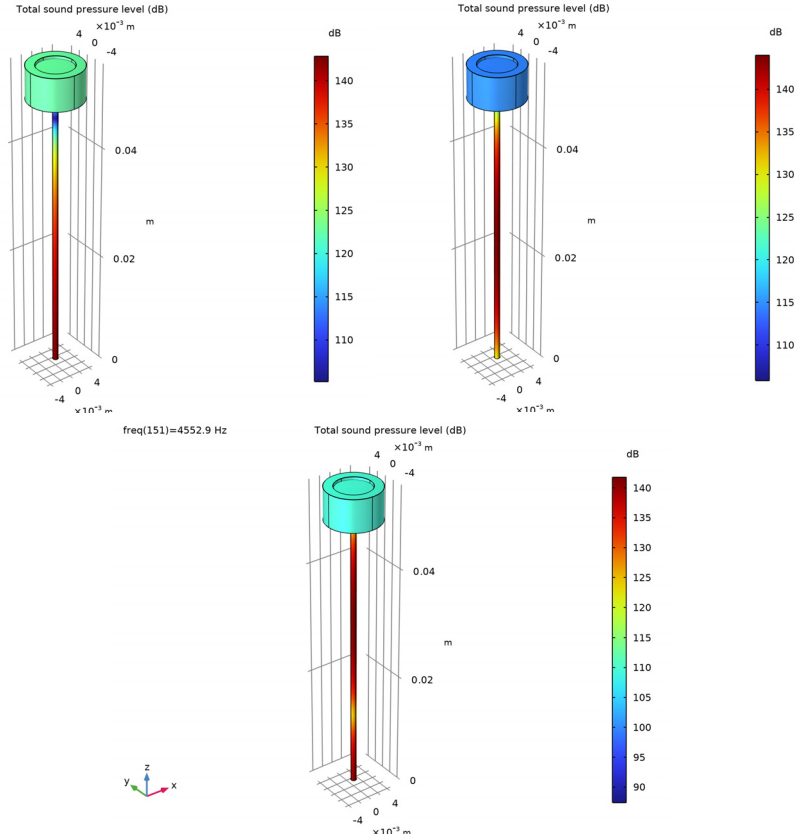

Figure 6: Sound pressure level at frequencies close to $f = 1200$, 3200 , and 4600 Hz.

Notes About the COMSOL Implementation

- In this model, the viscous and thermal losses associated with the acoustic boundary layer in the narrow tube are modeled using the Narrow Region Acoustics feature in Pressure acoustics. For long structures of constant cross section, the losses are exact when compared to a full thermoviscous acoustic model. The computational cost is low compared to the full thermoviscous model. However, for complex geometrical structures the Thermoviscous Acoustics physics interfaces should be used. Note also that the losses associated with the impedance jump from the narrow tube to the coupler are not modeled correctly with Narrow Region Acoustics. This effect is small when compared to the losses in the long tube.

- The Electrical Circuit interface uses electrical units. Conversion from electrical to acoustic lumped units are performed automatically in the Lumped port feature with the necessary units. For example, a voltage representing the acoustic pressure at the transducer inlet is transformed to volts, resulting in correct equivalent electric units volts.
- In the lumped Spice model of the receiver, the effects of variation in the skin depth of eddy currents in the steel armature is approximated by a semi-capacitor, a special component with a complex admittance proportional to the square root of $i\omega$. In the imported Spice net-list, the value of this component, here a resistor, is temporarily set to 1, using:

```
RKarm N0025 N0015 1
```

Then the correct value for this component is entered manually, as a formula, to fit the COMSOL notation:

```
1/(4.85e-11[1/ohm]*sqrt(i*2*pi*freq[1/Hz]))
```

The component is, in the unmodified Knowles Spice net-lists, included as an advanced voltage-controlled current source as:

```
GKarm N0025 N0015 laplace {V(N0025,N0015)}={4.85e-11*sqrt(s)}
```

This notation is not supported by the Spice import functionality of COMSOL.

References

1. *Generic 711 Coupler: An Occluded Ear-Canal Simulator* model in the Application Library of the Acoustics Module: `Acoustics_Module/Electroacoustic_Transducers/generic_711_coupler`.
2. J. Jensen, F.T. Agerkvist and J.M. Hart, “Nonlinear Time-Domain Modeling of Balanced Armature Receivers,” *J. Audio Eng. Soc.*, vol. 59, pp. 91–101, 2011.
3. *Lumped Loudspeaker Driver* model in the Application Library of the Acoustics Module: `Acoustics_Module/Electroacoustic_Transducers/lumped_loudspeaker_driver`.

Application Library path: `Acoustics_Module/Electroacoustic_Transducers/lumped_receiver_04cc`



Modeling Instructions

From the **File** menu, choose **New**.

NEW

In the **New** window, click  **Model Wizard**.

MODEL WIZARD

- 1 In the **Model Wizard** window, click .
- 2 In the **Select Physics** tree, select **AC/DC** > **Electrical Circuit (cir)**.
- 3 Click **Add**.
- 4 In the **Select Physics** tree, select **Acoustics** > **Pressure Acoustics** > **Pressure Acoustics, Frequency Domain (acpr)**.
- 5 Click **Add**.
- 6 Click  **Study**.
- 7 In the **Select Study** tree, select **General Studies** > **Frequency Domain**.
- 8 Click  **Done**.

ROOT

First, import the model parameters, import variables used in the model, and import the geometry. The instructions to the geometry can be found in the appendix at the end of this document.

GLOBAL DEFINITIONS

Parameters I

- 1 In the **Model Builder** window, under **Global Definitions** click **Parameters I**.
- 2 In the **Settings** window for **Parameters**, locate the **Parameters** section.
- 3 Click  **Load from File**.
- 4 Browse to the model's Application Libraries folder and double-click the file `lumped_receiver_04cc_parameters.txt`.

GEOMETRY I



- 1 In the **Geometry** toolbar, click **Insert Sequence** and choose **Insert Sequence**.
- 2 Browse to the model's Application Libraries folder and double-click the file `lumped_receiver_04cc_geom_sequence.mph`.

DEFINITIONS

Integration 1 (intop1)

- 1 In the **Definitions** toolbar, click  **Nonlocal Couplings** and choose **Integration**.
- 2 In the **Settings** window for **Integration**, type `intop_mic` in the **Operator name** text field.
- 3 Locate the **Source Selection** section. From the **Geometric entity level** list, choose **Boundary**.
- 4 Select Boundary 7 only.

ADD MATERIAL

- 1 In the **Home** toolbar, click  **Add Material** to open the **Add Material** window.
- 2 Go to the **Add Material** window.
- 3 In the tree, select **Built-in > Air**.
- 4 Right-click and choose **Add to Component 1 (comp1)**.
- 5 In the **Home** toolbar, click  **Add Material** to close the **Add Material** window.

Now, set up the circuit model. It includes the driving voltage source, the subcircuit for the receiver (imported), and the coupling node to the acoustic domain.

ELECTRICAL CIRCUIT (CIR)

Subcircuit Definition ED23146 (ED23146)

- 1 In the **Model Builder** window, under **Component 1 (comp1)** right-click **Electrical Circuit (cir)** and choose **Import SPICE Netlist**.
- 2 Browse to the model's Application Libraries folder and double-click the file `lumped_receiver_04cc_ED23146.cir`.
- 3 In the **Settings** window for **Subcircuit Definition**, locate the **Node Connections** section.
- 4 In the table, enter the following settings:

Node names
P1
N1
P2
N2

The component RKARM needs special attention by manual editing as it is a nontrivial function of frequency. The imported Spice net-list is courtesy of Knowles, IL, USA.

Resistor RKARM (RKARM)

- 1 In the **Model Builder** window, expand the **Subcircuit Definition ED23146 (ED23146)** node, then click **Resistor RKARM (RKARM)**.
- 2 In the **Settings** window for **Resistor**, locate the **Device Parameters** section.
- 3 In the R text field, type $1 / (4.85e-11 [1/\text{ohm}] * \text{sqrt}(i^2 * \pi * \text{freq} [1/\text{Hz}]))$.

Voltage Source 1 (V1)

- 1 In the **Electrical Circuit** toolbar, click  **Voltage Source**.
- 2 In the **Settings** window for **Voltage Source**, locate the **Node Connections** section.
- 3 In the table, enter the following settings:

Label	Node names
p	p1
n	0

- 4 Locate the **Device Parameters** section. In the v_{src} text field, type V0.

Subcircuit Instance 1 (X1)

- 1 In the **Electrical Circuit** toolbar, click  **Subcircuit Instance**.
- 2 In the **Settings** window for **Subcircuit Instance**, locate the **Node Connections** section.
- 3 From the **Subcircuit definition** list, choose **Subcircuit Definition ED23146 (ED23146)**.
- 4 In the table, enter the following settings:

Local node names	Node names
P1	p1
N1	0
P2	p2
N2	0

External I vs. U I (IvsUI)

- 1 In the **Electrical Circuit** toolbar, click  **External I vs. U**.
Set up the external source that couples to the **Lumped Port** feature. You will need to get back to this feature after setting up the port.
- 2 In the **Settings** window for **External I vs. U**, locate the **Node Connections** section.



3 In the table, enter the following settings:

Label	Node names
p	p2
n	0

The electrical circuit has now been set up. Proceed and set up the pressure acoustics physics.

GLOBAL DEFINITIONS

Interpolation 1 (int1)

- 1 In the **Home** toolbar, click  **Functions** and choose **Global > Interpolation**.
- 2 In the **Settings** window for **Interpolation**, locate the **Definition** section.
- 3 From the **Data source** list, choose **File**.
- 4 Click  **Browse**.
- 5 Browse to the model's Application Libraries folder and double-click the file `lumped_receiver_04cc_measured_data.txt`.
- 6 Locate the **Data Column Settings** section. In the table, enter the following settings:

Columns	Type	Settings
Re(VoltageSensitivity)	Function values	Function name=int1a
Im(VoltageSensitivity)	Function values	Function name=int1b
Re(InputImpedance)	Function values	Function name=int1
Im(InputImpedance)	Function values	Function name=int1c

- 7 In the table, click to select the cell at row number 1 and column number 1.
- 8 In the **Unit** text field, type Hz.
- 9 In the table, click to select the cell at row number 2 and column number 1.
- 10 In the **Name** text field, type `prea1`.
- 11 In the **Unit** text field, type `[Omega]`.
- 12 In the table, click to select the cell at row number 3 and column number 1.
- 13 In the **Name** text field, type `pimag`.
- 14 In the **Unit** text field, type `[Omega]`.
- 15 In the table, click to select the cell at row number 4 and column number 1.
- 16 In the **Name** text field, type `Zrea1`.

- 17 In the **Unit** text field, type [Omega].
- 18 In the table, click to select the cell at row number 5 and column number 1.
- 19 In the **Name** text field, type Zimag.
- 20 In the **Unit** text field, type [Omega].
- 21 Locate the **Interpolation and Extrapolation** section. From the **Interpolation** list, choose **Piecewise cubic**.
- 22 Locate the **Definition** section. Click  **Import**.

PRESSURE ACOUSTICS, FREQUENCY DOMAIN (ACPR)

Pressure Acoustics 1

- 1 In the **Model Builder** window, under **Component 1 (comp1) > Pressure Acoustics, Frequency Domain (acpr)** click **Pressure Acoustics 1**.
- 2 In the **Settings** window for **Pressure Acoustics**, locate the **Model Input** section.
- 3 In the T text field, type T0.
- 4 In the p_A text field, type p0.

Narrow Region Acoustics 1

- 1 In the **Physics** toolbar, click  **Domains** and choose **Narrow Region Acoustics**.
- 2 Select Domain 2 only.
- 3 In the **Settings** window for **Narrow Region Acoustics**, locate the **Model Input** section.
- 4 In the T text field, type T0.
- 5 In the p_A text field, type p0.
- 6 Locate the **Duct Properties** section. From the **Duct type** list, choose **Circular duct**.
- 7 In the a text field, type a.

Narrow Region Acoustics 2

- 1 In the **Physics** toolbar, click  **Domains** and choose **Narrow Region Acoustics**.
- 2 Select Domain 1 only.
- 3 In the **Settings** window for **Narrow Region Acoustics**, locate the **Model Input** section.
- 4 In the T text field, type T0.
- 5 In the p_A text field, type p0.
- 6 Locate the **Duct Properties** section. From the **Duct type** list, choose **Circular duct**.
- 7 In the a text field, type a_cp1.

Impedance I

- 1 In the **Physics** toolbar, click  **Boundaries** and choose **Impedance**.
- 2 Select Boundary 7 only.
- 3 In the **Settings** window for **Impedance**, locate the **Impedance** section.
- 4 From the **Impedance model** list, choose **RCL**.
- 5 In the R_{ac} text field, type Rmic.
- 6 In the C_{ac} text field, type Cmic.
- 7 In the L_{ac} text field, type Lmic.

Lumped Port I

- 1 In the **Physics** toolbar, click  **Boundaries** and choose **Lumped Port**.
The **Lumped Port** has built-in functionality that couples the port boundary to the Electrical Circuit physics.
- 2 Select Boundary 10 only.
- 3 In the **Settings** window for **Lumped Port**, locate the **Lumped Port Properties** section.
- 4 From the **Connection type** list, choose **Circuit**.
Now, finalize the coupling between the port and the circuit.

ELECTRICAL CIRCUIT (CIR)

External I vs. U I (IvsUI)

- 1 In the **Model Builder** window, under **Component 1 (comp1) > Electrical Circuit (cir)** click **External I vs. U I (IvsUI)**.
- 2 In the **Settings** window for **External I vs. U**, locate the **External Device** section.
- 3 From the V list, choose **Voltage from lumped port (acpr/lport1)**.
Now, mesh the geometry and then solve the model.

MESH I

Free Triangular I



- 1 In the **Mesh** toolbar, click  **More Generators** and choose **Free Triangular**.
- 2 Select Boundaries 3 and 11 only.

Size

- 1 In the **Model Builder** window, click **Size**.
- 2 In the **Settings** window for **Size**, locate the **Element Size** section.

- 3 Click the **Custom** button.
- 4 Locate the **Element Size Parameters** section. In the **Maximum element size** text field, type $3*a$.
- 5 In the **Minimum element size** text field, type $0.1 [mm]$.

Size 1

- 1 In the **Model Builder** window, right-click **Free Triangular 1** and choose **Size**.
- 2 In the **Settings** window for **Size**, locate the **Geometric Entity Selection** section.
- 3 Click  **Clear Selection**.
- 4 Select Boundary 11 only.
- 5 Locate the **Element Size** section. Click the **Custom** button.
- 6 Locate the **Element Size Parameters** section.
- 7 Select the **Maximum element size** checkbox. In the associated text field, type a .
- 8 Click  **Build Selected**.

Swept 1

- 1 In the **Mesh** toolbar, click  **Swept**.
- 2 In the **Settings** window for **Swept**, locate the **Domain Selection** section.
- 3 From the **Geometric entity level** list, choose **Domain**.
- 4 Select Domain 2 only.

Distribution 1

- 1 Right-click **Swept 1** and choose **Distribution**.
- 2 In the **Settings** window for **Distribution**, locate the **Distribution** section.
- 3 In the **Number of elements** text field, type 15.
- 4 Click  **Build Selected**.

Free Tetrahedral 1

- 1 In the **Mesh** toolbar, click  **Free Tetrahedral**.

2 In the **Settings** window for **Free Tetrahedral**, click  **Build All**.

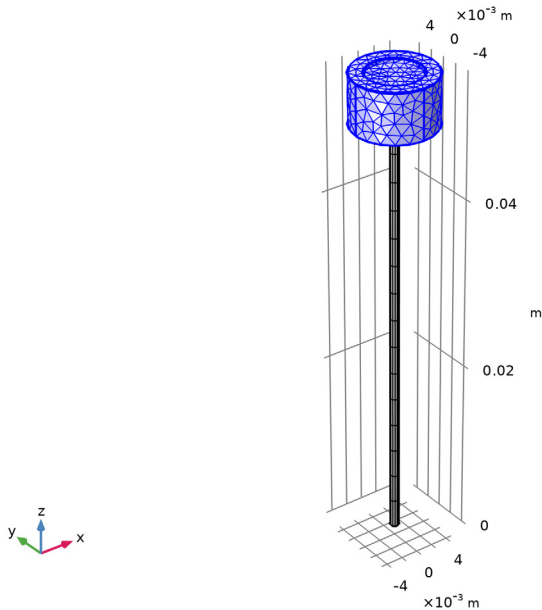

Solve the model. First, solve the full model including the equivalent acoustic loss model. Secondly, solve the model without the losses. Do this by deactivating the Narrow Region Acoustics domain features in the second study.

STUDY 1 - NARROW REGION

- 1 In the **Model Builder** window, click **Study 1**.
- 2 In the **Settings** window for **Study**, type Study 1 - Narrow Region in the **Label** text field.
- 3 Locate the **Study Settings** section. Clear the **Generate default plots** checkbox.

Step 1: Frequency Domain



- 1 In the **Model Builder** window, under **Study 1 - Narrow Region** click **Step 1: Frequency Domain**.
- 2 In the **Settings** window for **Frequency Domain**, locate the **Study Settings** section.
- 3 In the **Frequencies** text field, type $10^{\{\text{range}(2, 2.2/199, 4.2)\}}$.
- 4 In the **Study** toolbar, click  **Compute**.

ADD STUDY

- 1 In the **Home** toolbar, click  **Add Study** to open the **Add Study** window.

- 2 Go to the **Add Study** window.
- 3 Find the **Studies** subsection. In the **Select Study** tree, select **General Studies > Frequency Domain**.
- 4 Click the **Add Study** button in the window toolbar.
- 5 In the **Home** toolbar, click  **Add Study** to close the **Add Study** window.

STUDY 2 - LOSSLESS ACOUSTICS

- 1 In the **Settings** window for **Study**, type Study 2 - Lossless Acoustics in the **Label** text field.
- 2 Locate the **Study Settings** section. Clear the **Generate default plots** checkbox.
 - 1 In the **Model Builder** window, under **Study 2 - Lossless Acoustics** click **Step 1: Frequency Domain**.
 - 2 In the **Settings** window for **Frequency Domain**, locate the **Study Settings** section.
 - 3 In the **Frequencies** text field, type $10^{\{\text{range}(2, 2.2/199, 4.2)\}}$.
 - 4 Locate the **Physics and Variables Selection** section. Select the **Modify model configuration for study step** checkbox.
 - 5 In the tree, select **Component 1 (comp1) > Pressure Acoustics, Frequency Domain (acpr) > Narrow Region Acoustics 1**.
 - 6 Click  **Disable**.
 - 7 In the tree, select **Component 1 (comp1) > Pressure Acoustics, Frequency Domain (acpr) > Narrow Region Acoustics 2**.
 - 8 Click  **Disable**.
 - 9 In the **Study** toolbar, click  **Compute**.

RESULTS

Microphone Response

- 1 In the **Model Builder** window, expand the **Results** node.
- 2 Right-click **Results** and choose **ID Plot Group**.
- 3 In the **Settings** window for **ID Plot Group**, type Microphone Response in the **Label** text field.
- 4 Click to expand the **Title** section. From the **Title type** list, choose **Manual**.
- 5 In the **Title** text area, type Coupler Response (50mm/1mmØ tube on 0.4cc coupler).
- 6 Locate the **Plot Settings** section.

- 7 Select the **y-axis label** checkbox. In the associated text field, type Level (dB rel. 1V).
- 8 Locate the **Legend** section. From the **Position** list, choose **Lower left**.

Global 1



- 1 Right-click **Microphone Response** and choose **Global**.
- 2 In the **Settings** window for **Global**, locate the **y-Axis Data** section.
- 3 In the table, enter the following settings:

Expression	Unit	Description
$20 \cdot \log_{10}(\text{abs}(\text{intop_mic}(p)) / \text{intop_mic}(1)) / V_0$		Full model
$20 \cdot \log_{10}(\text{abs}(\text{preal}(\text{freq}) + i \cdot \text{pimag}(\text{freq})))$		Knowles measurements

Global 2

- 1 In the **Model Builder** window, right-click **Microphone Response** and choose **Global**.
- 2 In the **Settings** window for **Global**, locate the **Data** section.
- 3 From the **Dataset** list, choose **Study 2 - Lossless Acoustics/Solution 2 (sol2)**.
- 4 Locate the **y-Axis Data** section. In the table, enter the following settings:

Expression	Unit	Description
$20 \cdot \log_{10}(\text{abs}(\text{intop_mic}(p)) / \text{intop_mic}(1)) / V_0$		Model without acoustic losses

- 5 In the **Microphone Response** toolbar, click  **Plot**.
- 6 Click to expand the **Coloring and Style** section. Find the **Line style** subsection. From the **Line** list, choose **Dotted**.
- 7 Click the  **x-Axis Log Scale** button in the **Graphics** toolbar.

The modeled and measured microphone response are depicted in [Figure 3](#).

Electric Input Impedance



- 1 In the **Results** toolbar, click  **ID Plot Group**.
- 2 In the **Settings** window for **ID Plot Group**, type Electric Input Impedance in the **Label** text field.
- 3 Locate the **Title** section. From the **Title type** list, choose **Label**.
- 4 Locate the **Plot Settings** section.
- 5 Select the **y-axis label** checkbox. In the associated text field, type Z_in (Ohm).

- Click to collapse the **Legend** section. Click to expand the **Legend** section. From the **Position** list, choose **Upper left**.





Global 1

- Right-click **Electric Input Impedance** and choose **Global**.
- In the **Settings** window for **Global**, locate the **y-Axis Data** section.
- In the table, enter the following settings:

Expression	Unit	Description
$\text{real}(-\text{cir.V1.v}/\text{cir.V1.i})$	Ω	real(Zin): Model results
$\text{imag}(-\text{cir.V1.v}/\text{cir.V1.i})$	Ω	imag(Zin): Model results
Zreal(freq)		real(Zin): Knowles measurements
Zimag(freq)		imag(Zin): Knowles measurements

- In the **Electric Input Impedance** toolbar, click  **Plot**.
- Click the  **x-Axis Log Scale** button in the **Graphics** toolbar.
The electric input impedance graph is depicted in [Figure 4](#).

RESULT TEMPLATES

- In the **Results** toolbar, click  **Result Templates** to open the **Result Templates** window.
- Go to the **Result Templates** window.
- In the tree, select **Study 1 - Narrow Region/Solution 1 (sol1) > Pressure Acoustics, Frequency Domain > Acoustic Pressure (acpr)**.
- Click the **Add Result Template** button in the window toolbar.
- In the **Results** toolbar, click  **Result Templates** to close the **Result Templates** window.
Change the evaluation frequency and plot the pressure at the desired frequencies. The pressure is depicted in [Figure 5](#) at the first three resonance peaks.
- In the **Results** toolbar, click  **Result Templates** to open the **Result Templates** window.
- Go to the **Result Templates** window.
- In the tree, select **Study 1 - Narrow Region/Solution 1 (sol1) > Pressure Acoustics, Frequency Domain > Sound Pressure Level (acpr)**.
- Click the **Add Result Template** button in the window toolbar.
- In the **Results** toolbar, click  **Result Templates** to close the **Result Templates** window.
Change the evaluation frequency and plot the sound pressure level at the desired frequencies. The sound pressure level is depicted in [Figure 6](#) at the first three resonance peaks.

ADD COMPONENT

In the **Home** toolbar, click  **Add Component** and choose **3D**.

GEOMETRY 1

Cylinder 1 (cyl1)

- 1 In the **Geometry** toolbar, click  **Cylinder**.
- 2 In the **Settings** window for **Cylinder**, locate the **Selections of Resulting Entities** section.
- 3 Select the **Resulting objects selection** checkbox.
- 4 Locate the **Size and Shape** section. In the **Radius** text field, type 0.5[mm].
- 5 In the **Height** text field, type 49[mm].



Cylinder 2 (cyl2)

- 1 In the **Geometry** toolbar, click  **Cylinder**.
- 2 In the **Settings** window for **Cylinder**, locate the **Selections of Resulting Entities** section.
- 3 Select the **Resulting objects selection** checkbox.
- 4 Locate the **Size and Shape** section. In the **Radius** text field, type 4.72[mm].
- 5 In the **Height** text field, type 5.7[mm].
- 6 Locate the **Position** section. In the **z** text field, type 49[mm].

Cylinder 3 (cyl3)

- 1 In the **Geometry** toolbar, click  **Cylinder**.
- 2 In the **Settings** window for **Cylinder**, locate the **Size and Shape** section.
- 3 In the **Radius** text field, type 3.175[mm].
- 4 In the **Height** text field, type 0.5[mm].
- 5 Locate the **Position** section. In the **z** text field, type 54.2[mm].

Difference 1 (dif1)

- 1 In the **Geometry** toolbar, click  **Booleans and Partitions** and choose **Difference**.
- 2 Select the object **cyl2** only.
- 3 In the **Settings** window for **Difference**, locate the **Difference** section.
- 4 Click to select the  **Activate Selection** toggle button for **Objects to subtract**.
- 5 Select the object **cyl3** only.



Form Union (fin)

- 1 In the **Model Builder** window, click **Form Union (fin)**.
- 2 In the **Settings** window for **Form Union/Assembly**, click  **Build Selected**.

Normal Acceleration

- 1 In the **Geometry** toolbar, click  **Selections** and choose **Explicit Selection**.
- 2 In the **Settings** window for **Explicit Selection**, type Normal Acceleration in the **Label** text field.
- 3 Locate the **Entities to Select** section. From the **Geometric entity level** list, choose **Boundary**.
- 4 On the object **fin**, select Boundary 10 only.

Impedance

- 1 In the **Geometry** toolbar, click  **Selections** and choose **Explicit Selection**.
- 2 In the **Settings** window for **Explicit Selection**, type Impedance in the **Label** text field.
- 3 Locate the **Entities to Select** section. From the **Geometric entity level** list, choose **Boundary**.
- 4 On the object **fin**, select Boundary 7 only.
- 5 In the **Geometry** toolbar, click  **Build All**.