



Model created in COMSOL Multiphysics 6.4

# Loudspeaker Driver in 3D – Frequency-Domain Analysis

## Introduction

---

This tutorial shows how to best solve full 3D electro-vibroacoustic multiphysics models of a loudspeaker driver. The model is a 3D version of the existing 2D axisymmetric Application Library model [Loudspeaker Driver — Frequency-Domain Analysis](#). In the 3D model, certain geometry details are no longer axisymmetric, for example, the basket geometry and the presence of a hole in the former. The setup of the physics is essentially the same in this 3D version as in the 2D axisymmetric version. The current 3D model discusses and shows best practices for solving the coupled acoustic, structural, and electromagnetic multiphysics problem efficiently using an iterative solver.

## Model Definition

---

The geometry of the loudspeaker driver analyzed in this tutorial is presented in [Figure 1](#). The model solves for 1/4 of the full geometry and symmetries are applied to the sides. Specifically, the basket structure is included here and it is not axisymmetric (see also [Figure 2](#)), as compared to the 2D axisymmetric geometry used in the [Loudspeaker Driver — Frequency-Domain Analysis](#) model. There is also a small venting hole in the former.

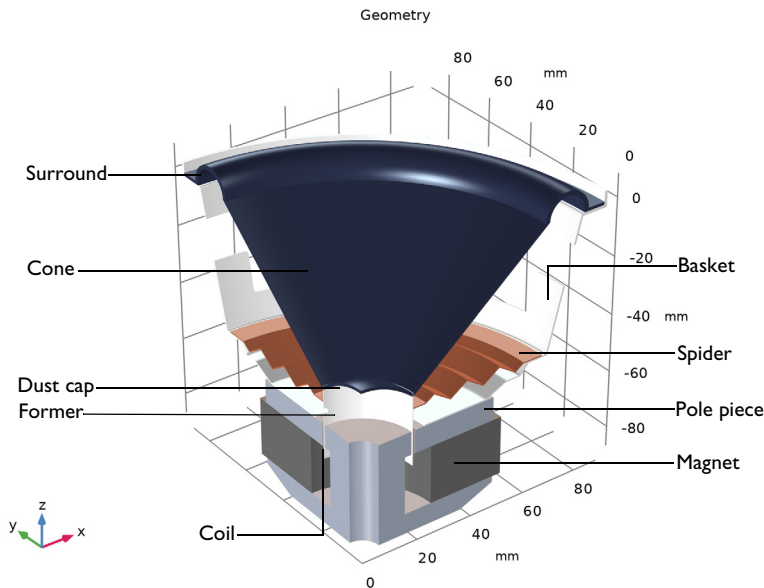

*Figure 1: Loudspeaker driver geometry and definitions of various components.*

The setup of the physics as well as the material properties correspond very closely to the setup used in the 2D axisymmetric version of the model. All the details can be found in the [Loudspeaker Driver — Frequency-Domain Analysis](#) model.

## Results and Discussion

---

The stationary magnetic field generated by the permanent magnets is depicted in [Figure 2](#). This DC magnetic field is used as the linearization point for the small signal or AC frequency domain perturbation analysis.

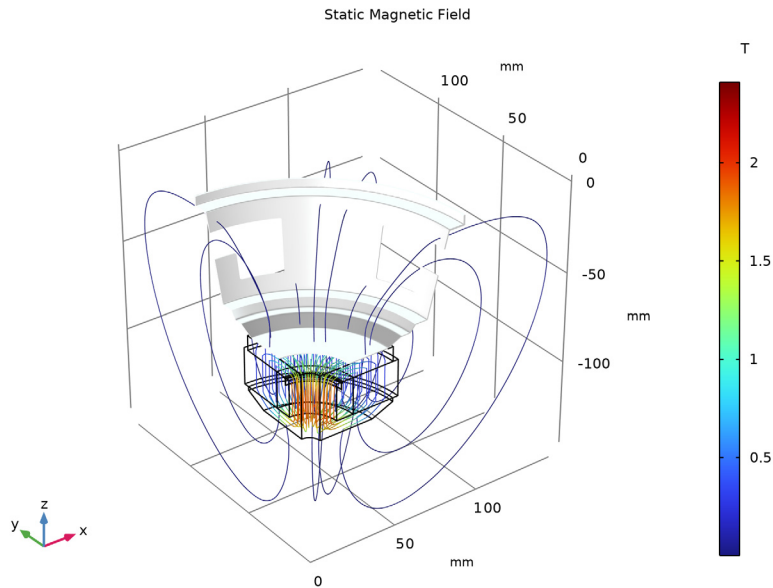

*Figure 2: Static magnetic flux density (field lines) of the permanent magnet.*

Some important electromagnetic quantities are plotted in [Figure 3](#), [Figure 4](#), and [Figure 5](#). In the first figure, the current density norm is depicted at 500 Hz. From the color range bar, it is evident that a high current density exists in the model; this is the current in the surface of the conducting structures (pole piece and basket) within the skin-depth region. Zooming in the model or selecting a lower frequency makes this more evident. In [Figure 4](#), the  $x$ - and  $y$ -components of the current density vector are depicted in the coil domain. Then in [Figure 5](#), the  $z$ -component of the Lorentz force acting on the coil domain is plotted, also at 500 Hz. This is the variable `mmcp11.FLTzz`. Since this force term is a nonlinear expression of the electromagnetic quantities, it is very important to

select the **Compute differential** option in the plot, when evaluating it. This will ensure that it is evaluated as a linearized perturbation around the DC magnetic solution. If this option is not selected, the evaluated results will be unphysical.

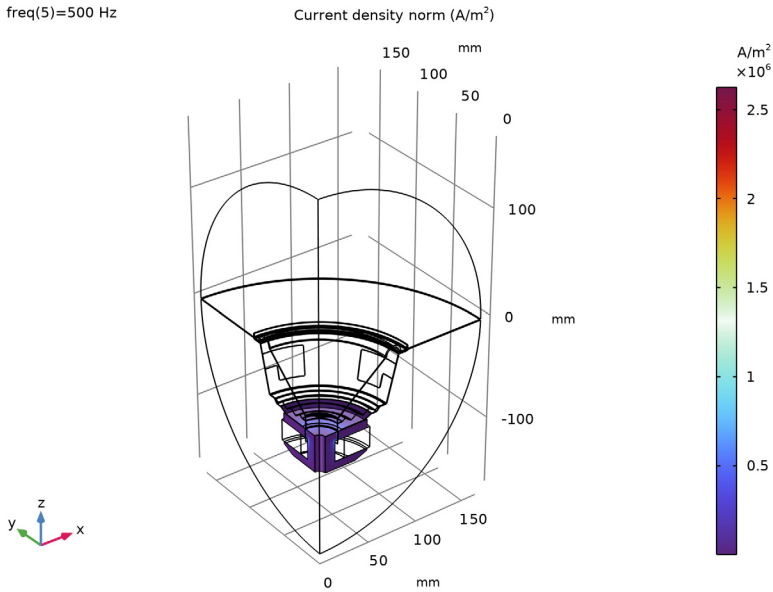

Figure 3: Current density in the pole piece and part of the aluminum basket evaluated at 500 Hz.

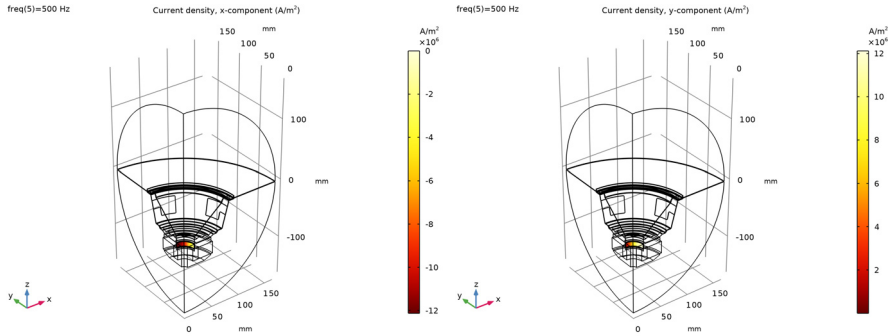
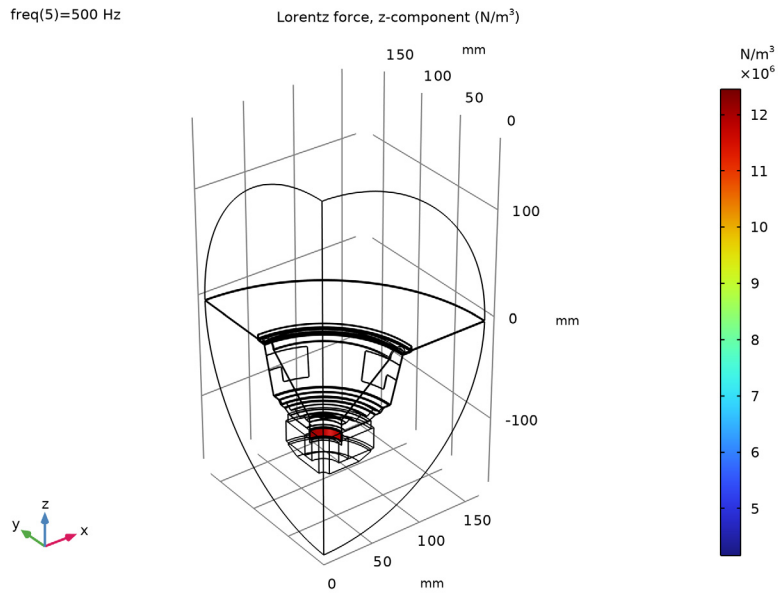
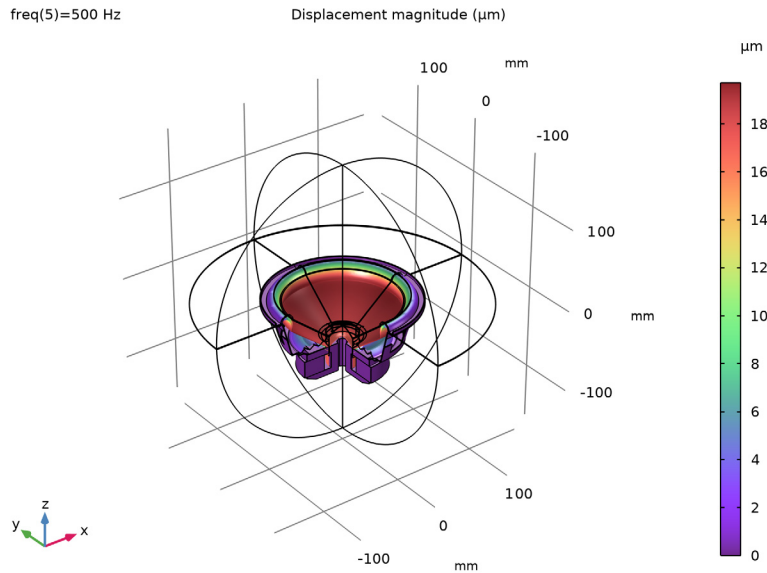

Figure 4: x- and y-components of the current density in the coil domain.



*Figure 5: Evaluation of the z-component of the Lorentz-force in the coil domain.*

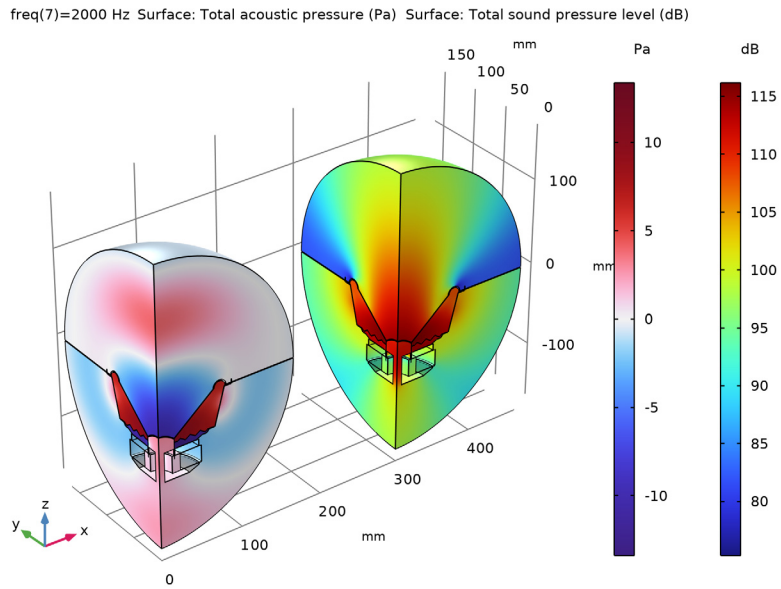

*Figure 6: Structural displacement of the moving parts of the loudspeaker evaluated at 500 Hz.*

The displacement of the structural parts of the speaker is depicted in [Figure 6](#), here evaluated at 500 Hz. It is evident that at this frequency the driver is still behaving like a piston. The acoustic pressure and the sound pressure level at 2000 Hz are plotted in [Figure 7](#).

The loudspeaker on-axis sensitivity is depicted in [Figure 8](#) while the spatial response in the  $yz$ -plane for some selected frequencies is depicted in [Figure 9](#). The real, imaginary, and absolute values of the voice-coil impedance is plotted in [Figure 10](#) as a function of frequency.

Finally, [Figure 11](#) displays the results of a pure structural eigenfrequency analysis, depicting the first six eigenfrequencies and associated eigenmodes. Note that the use of the symmetries of the model limit the solution space.



*Figure 7: Pressure and sound pressure level distribution outside the speaker evaluated at 2000 Hz.*

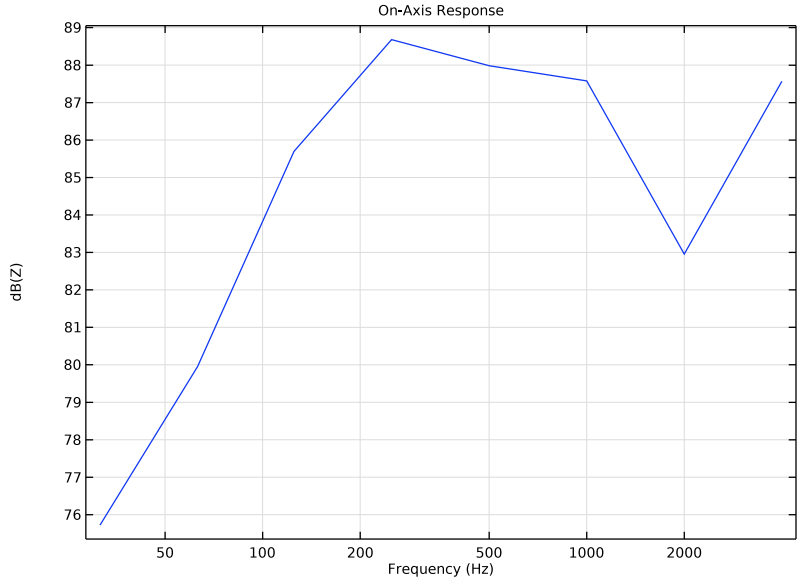

Figure 8: Loudspeaker sensitivity (on-axis response).

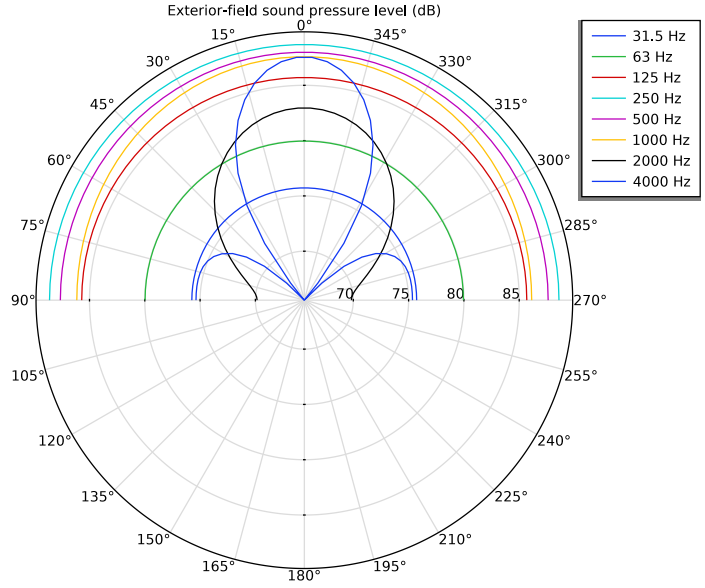

Figure 9: Spatial response in the yz-plane.

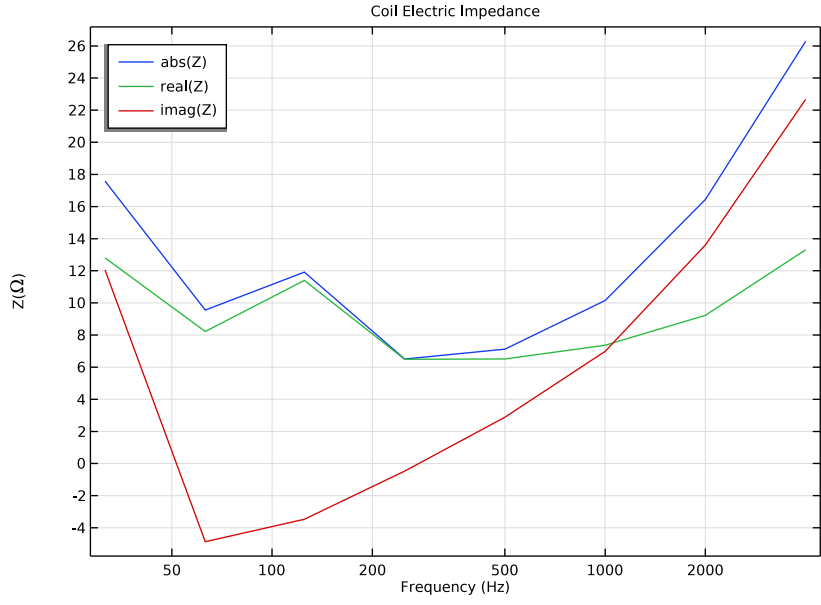

Figure 10: Electric impedance of the voice coil.

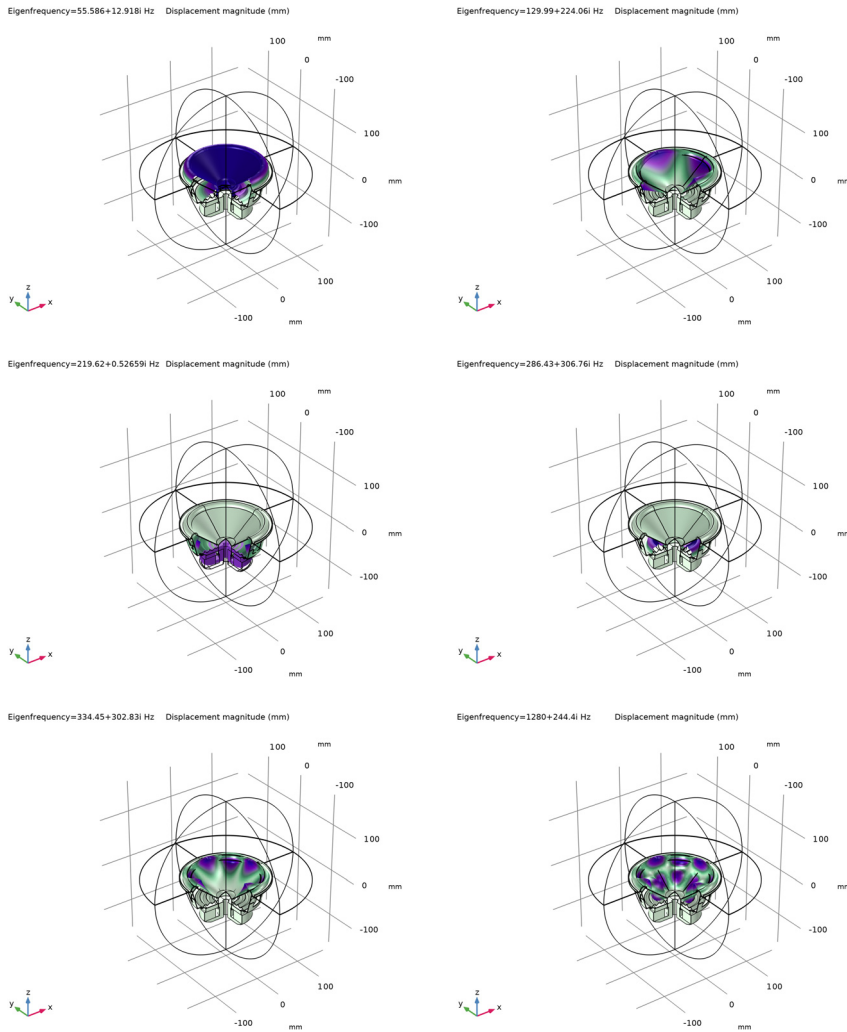

Figure 11: The first six structural mode shapes.

### Notes About the COMSOL Implementation

To solve a full vibroelectroacoustic model of a loudspeaker driver in 3D, it is necessary to use an iterative solver. In this model, the automatically generated solver suggestion is selected and used for the frequency-domain analysis. To ensure good performance of the

iterative method it is necessary to set a small numerical (stabilizing) electric conductivity in the nonconductive domains. This is achieved automatically in the air domains when using the default **Free Space** feature.

The value of this electric conductivity at audio frequencies is approximately set so that it results in an effective skin depth (at the given frequency) that is 50 times larger than the geometry dimensions of the model. This gives the definition

$$\sigma_{\text{num}} = \frac{2}{\omega\mu_0\delta_S^2}$$

where the skin depth  $\delta_S$  is chosen such that it is 50 times the geometric dimension of the model, here 50 times the radius of the air domain, which is 165 mm.

In the **Free Space** feature of the model, the skin depth is manually set to the above mentioned value. This value is a bit less conservative than the automatic option and gives faster convergence. For a frequency-dependent study, the stabilizing conductivity will use the given frequency solved for. For the stationary study it will use the fallback value, but here the conductivity has no influence on the solution. The fallback value becomes important for transient models.

---

**Application Library path:** Acoustics\_Module/Electroacoustic\_Transducers/loudspeaker\_driver\_3d

---

### *Modeling Instructions*

---



From the **File** menu, choose **New**.

#### **NEW**

In the **New** window, click  **Model Wizard**.

#### **MODEL WIZARD**

- 1 In the **Model Wizard** window, click  **3D**.
- 2 In the **Select Physics** tree, select **AC/DC > Electromagnetic Fields > Magnetic Fields (mf)**.
- 3 Click **Add**.
- 4 In the **Select Physics** tree, select **Acoustics > Pressure Acoustics > Pressure Acoustics, Frequency Domain (acpr)**.

- 5 Click **Add**.
- 6 In the **Select Physics** tree, select **Structural Mechanics > Solid Mechanics (solid)**.
- 7 Click **Add**.
- 8 Click  **Study**.
- 9 In the **Select Study** tree, select **Preset Studies for Some Physics Interfaces > Coil Geometry Analysis**.
- 10 Click  **Done**.

## GLOBAL DEFINITIONS

### *Parameters 1*

The model parameters are loaded from the file `loudspeaker_driver_3d_parameters.txt`.



- 1 In the **Model Builder** window, under **Global Definitions** click **Parameters 1**.
- 2 In the **Settings** window for **Parameters**, locate the **Parameters** section.
- 3 Click  **Load from File**.
- 4 Browse to the model's Application Libraries folder and double-click the file `loudspeaker_driver_3d_parameters.txt`.

## GEOMETRY 1

- 1 In the **Model Builder** window, under **Component 1 (comp1)** click **Geometry 1**.
- 2 In the **Settings** window for **Geometry**, locate the **Units** section.
- 3 From the **Length unit** list, choose **mm**.
- 4 Locate the **Advanced** section. From the **Geometry representation** list, choose **CAD kernel**.

In this model, the geometry is imported as a sequence from the geometry file. Symmetry planes are used to only model a quarter of the geometry and reduce the number of degrees of freedom to solve for. The instructions to the geometry can be found in the appendix at the end of this document.

### *Import 1 (imp1)*

- 1 In the **Geometry** toolbar, click  **Import**.
- 2 In the **Settings** window for **Import**, locate the **Source** section.
- 3 Click  **Browse**.
- 4 Browse to the model's Application Libraries folder and double-click the file `loudspeaker_driver_3d.mphbin`.

5 Click  **Import**.

6 In the **Home** toolbar, click  **Build All**.



## DEFINITIONS

Create selections to make the physics setup easier.

### *Symmetry*

- 1 In the **Definitions** toolbar, click  **Explicit**.
- 2 In the **Settings** window for **Explicit**, type *Symmetry* in the **Label** text field.
- 3 Locate the **Input Entities** section. From the **Geometric entity level** list, choose **Boundary**.
- 4 Select Boundaries 1, 2, 4, 5, 7, 8, 11, 15, 21, 25, 28, 31, 34, 37, 40, 43, 45, 48, 51, 56, 59, 62, 65, 69, 72, 75, 80, 85, 91, 97, 132, 138, 146, 152, 155, 160, 174, 180–200, 205, 212, 219, and 221–223 only.
- 5 Select the **Group by continuous tangent** checkbox.

### *Coil*

- 1 In the **Definitions** toolbar, click  **Explicit**.
- 2 In the **Settings** window for **Explicit**, type *Coil* in the **Label** text field.
- 3 Click the  **Wireframe Rendering** button in the **Graphics** toolbar.
- 4 Select Domains 16–18 only.

### *Air Domain*

- 1 In the **Definitions** toolbar, click  **Explicit**.
- 2 In the **Settings** window for **Explicit**, type *Air Domain* in the **Label** text field.
- 3 Select Domains 1, 3, 5, 6, 12, 19, 21, 23, 29, and 32 only.

### *Aluminum Domain*

- 1 In the **Definitions** toolbar, click  **Explicit**.
- 2 In the **Settings** window for **Explicit**, type *Aluminum Domain* in the **Label** text field.
- 3 Select Domains 25, 27, and 30 only.

### *Magnet*

- 1 In the **Definitions** toolbar, click  **Explicit**.
- 2 In the **Settings** window for **Explicit**, type *Magnet* in the **Label** text field.
- 3 Select Domain 26 only.

### *Variables 1*

In the **Model Builder** window, right-click **Definitions** and choose **Variables**.

### *Pole Pieces*

- 1 In the **Definitions** toolbar, click  **Explicit**.
- 2 In the **Settings** window for **Explicit**, type Pole Pieces in the **Label** text field.
- 3 Select Domains 4 and 24 only.

### *Nonconductive Solid Domains*



- 1 In the **Definitions** toolbar, click  **Explicit**.
- 2 In the **Settings** window for **Explicit**, type Nonconductive Solid Domains in the **Label** text field.
- 3 Select Domains 7–11, 13, 14, and 20 only.

## **MATERIALS**

While the material properties used in this model are partly made up, they resemble those used in a real driver. The coil former has properties representative of glass fiber materials. The spider, acting as a spring, is made of a phenolic cloth with a much lower stiffness. The material used in the coil is taken to be lighter than copper, as the wire is insulated and does not completely fill the coil domain. The surround, finally, is a light resistive foam.

Except for air and soft iron, the materials all come from a library created especially for this model (loaded from the file `loudspeaker_driver_materials.mph`). You may notice that some of the materials report missing properties. For example, the composite does not include any electromagnetic properties. This is not a problem, as the magnetic fields will not be modeled in the domains where the composite is used.

## **ADD MATERIAL**

- 1 In the **Materials** toolbar, click  **Add Material** to open the **Add Material** window.
- 2 Go to the **Add Material** window.
- 3 In the tree, select **Built-in > Air**.
- 4 Click the **Add to Component** button in the window toolbar.
- 5 In the tree, select **AC/DC > Soft Iron (With Losses)**.
- 6 Click the **Add to Component** button in the window toolbar.
- 7 In the tree, select **Built-in > Aluminum**.
- 8 Click the **Add to Component** button in the window toolbar.
- 9 In the **Materials** toolbar, click  **Add Material** to close the **Add Material** window.

## MATERIALS

*Aluminum (mat3)*

In the **Materials** toolbar, click  **Browse Materials**.

## MATERIAL BROWSER

**1** In the **Material Browser** window, In the ribbon make sure to select the **Materials** tab and then click the **Browse Materials** icon.

The **Import Material Library** functionality is activated by clicking the small icon below the Material Browser tree.

**2** click  **Import Material Library**.

**3** Browse to the model's Application Libraries folder and double-click the file `loudspeaker_driver_materials.mph`.

**4** In the tree, select **loudspeaker driver materials > Composite**.

**5** Click  **Add to Component**.

**6** In the tree, select **loudspeaker driver materials > Cloth**.

**7** Click  **Add to Component**.

**8** In the tree, select **loudspeaker driver materials > Foam**.

**9** Click  **Add to Component**.

**10** In the tree, select **loudspeaker driver materials > Coil**.

**11** Click  **Add to Component**.

**12** In the tree, select **loudspeaker driver materials > Glass Fiber**.

**13** Click  **Add to Component**.

**14** In the tree, select **loudspeaker driver materials > Generic Ferrite**.

**15** Click  **Add to Component**.

**16** Click  **Done**.

## MATERIALS

*Soft Iron (With Losses) (mat2)*

**1** In the **Model Builder** window, under **Component 1 (comp1) > Materials** click **Soft Iron (With Losses) (mat2)**.

**2** In the **Settings** window for **Material**, locate the **Geometric Entity Selection** section.

**3** From the **Selection** list, choose **Pole Pieces**.

4 Locate the **Material Contents** section. In the table, enter the following settings:

| Property        | Variable | Value                      | Unit              | Property group                      |
|-----------------|----------|----------------------------|-------------------|-------------------------------------|
| Density         | rho      | 7800 [ kg/m <sup>3</sup> ] | kg/m <sup>3</sup> | Basic                               |
| Young's modulus | E        | 180 [ GPa ]                | Pa                | Young's modulus and Poisson's ratio |
| Poisson's ratio | nu       | 0.29                       | l                 | Young's modulus and Poisson's ratio |

#### *Aluminum (mat3)*

- 1 In the **Model Builder** window, click **Aluminum (mat3)**.
- 2 In the **Settings** window for **Material**, locate the **Geometric Entity Selection** section.
- 3 From the **Selection** list, choose **Aluminum Domain**.

#### *Composite (mat4)*

- 1 In the **Model Builder** window, click **Composite (mat4)**.
- 2 Select Domains 2 and 22 only.

#### *Cloth (mat5)*

- 1 In the **Model Builder** window, click **Cloth (mat5)**.
- 2 Select Domain 20 only.

#### *Foam (mat6)*

- 1 In the **Model Builder** window, click **Foam (mat6)**.
- 2 Select Domains 28 and 31 only.

#### *Coil (mat7)*

- 1 In the **Model Builder** window, click **Coil (mat7)**.
- 2 In the **Settings** window for **Material**, locate the **Geometric Entity Selection** section.
- 3 From the **Selection** list, choose **Coil**.

#### *Glass Fiber (mat8)*

- 1 In the **Model Builder** window, click **Glass Fiber (mat8)**.
- 2 Select Domains 7–11 and 13–15 only.

#### *Generic Ferrite (mat9)*

- 1 In the **Model Builder** window, click **Generic Ferrite (mat9)**.
- 2 In the **Settings** window for **Material**, locate the **Geometric Entity Selection** section.
- 3 From the **Selection** list, choose **Magnet**.

## MAGNETIC FIELDS (MF)

The **Magnetic Fields** physics is solved in and around the magnetic motor. To reduce simulation time, make this physics interface active only where it is needed. You can remove all domains where you expect the magnetic field to be negligible.

- 1 In the **Model Builder** window, under **Component 1 (comp1)** click **Magnetic Fields (mf)**.
- 2 In the **Settings** window for **Magnetic Fields**, locate the **Domain Selection** section.
- 3 From the **Selection** list, choose **Manual**.
- 4 Select Domains 1, 4–14, 16–21, 23–27, 29, and 32 only.

### *Free Space I*

The **Free Space** feature is per default assigned to all domains where the physics interface is active (and is here used in the Air domains). Add Ampère's Law in the remaining domains where different constitutive relations are needed.

The **Stabilization conductivity** is here defined using the **From skin depth** option. This adds an artificial electric conductivity, used to stabilize the numerical method, which gives a skin depth equal to 50 times the radius of the air domain (165 mm). This value is a bit less conservative than the automatic option and gives a faster convergence. For a frequency dependent study the stabilizing conductivity will use the given frequency solved for. For the stationary study it will use the fallback value, but here the conductivity has no influence on the solution. The fallback value becomes important for transient models.

- 1 In the **Model Builder** window, under **Component 1 (comp1) > Magnetic Fields (mf)** click **Free Space I**.
- 2 In the **Settings** window for **Free Space**, locate the **Stabilization** section.
- 3 From the  $\sigma_{\text{stab}}$  list, choose **From skin depth**.
- 4 Find the **Skin depth** subsection. In the  $\delta_s$  text field, type `deltas`.

### *Ampère's Law in Solids I*

- 1 In the **Physics** toolbar, click  **Domains** and choose **Ampère's Law in Solids**.
- 2 In the **Settings** window for **Ampère's Law in Solids**, locate the **Domain Selection** section.
- 3 From the **Selection** list, choose **Nonconductive Solid Domains**.

In the nonconductive solid domains a small conductivity value of 5 S/m is used. The exact value used will have a very small influence on the results when compared to other numerical factors like, for example, the mesh resolution. For numerical reasons it is best to avoid the use of zero conductivity.

- 4 In the **Model Builder** window, click **Ampère's Law in Solids I**.

- 5 Locate the **Constitutive Relation Jc-E** section. From the  $\sigma$  list, choose **User defined**. In the associated text field, type 5[S/m].

#### *Ampère's Law in Solids 2*

- 1 In the **Physics** toolbar, click  **Domains** and choose **Ampère's Law in Solids**.
- 2 In the **Settings** window for **Ampère's Law in Solids**, locate the **Domain Selection** section.
- 3 From the **Selection** list, choose **Magnet**.
- 4 Locate the **Constitutive Relation B-H** section. From the **Magnetization model** list, choose **Remanent flux density**.
- 5 Specify the **e** vector as

|   |   |
|---|---|
| 0 | x |
| 0 | y |
| 1 | z |

- 6 Locate the **Constitutive Relation Jc-E** section. From the  $\sigma$  list, choose **User defined**. In the associated text field, type 5[S/m].

This setting gives a static remanent flux density equal to 0.4 T in the  $z$  direction. This will create a static magnetic field distribution in the model, providing the linearization point for the frequency domain study.

#### *Ampère's Law in Solids 3*

- 1 In the **Physics** toolbar, click  **Domains** and choose **Ampère's Law in Solids**.
- 2 In the **Settings** window for **Ampère's Law in Solids**, locate the **Domain Selection** section.
- 3 From the **Selection** list, choose **Pole Pieces**.
- 4 Locate the **Constitutive Relation B-H** section. From the **Magnetization model** list, choose **B-H curve**.

The B-H curve is provided by the soft iron material.

#### *Ampère's Law in Solids 4*

- 1 In the **Physics** toolbar, click  **Domains** and choose **Ampère's Law in Solids**.
- 2 In the **Settings** window for **Ampère's Law in Solids**, locate the **Domain Selection** section.
- 3 From the **Selection** list, choose **Aluminum Domain**.

#### *Domain Coil 1*

- 1 In the **Physics** toolbar, click  **Domains** and choose **Domain Coil**.
- 2 In the **Settings** window for **Domain Coil**, locate the **Domain Selection** section.

- 3 From the **Selection** list, choose **Coil**.
- 4 Locate the **Coil** section. From the **Conductor model** list, choose **Homogenized multiturn**.
- 5 From the **Coil type** list, choose **Numeric**.
- 6 From the **Coil excitation** list, choose **Voltage**.
- 7 In the  $V_{\text{coil}}$  text field, type `linper(V0)`.  
This is the driving voltage. Because the `linper()` operator is used it will only be active in the **Frequency Domain, Perturbation** study.
- 8 Locate the **Homogenized Conductor** section. In the  $N$  text field, type  $N0$ .
- 9 From the list, choose **User defined**.
- 10 Find the **High-frequency effective loss** subsection. Clear the **Include harmonic loss** checkbox.
- 11 In the  $a$  text field, type `3.5e-8[m^2]`.  
With  $N0 = 100$  turns, the total cross-sectional area covered by the wires will be  $3.5e-8 \text{ m}^2$ . The area of the coil domain is  $6e-8 \text{ m}^2$ , making the fill factor approximately 60%.

#### *Geometry Analysis I*

- 1 In the **Model Builder** window, expand the **Component 1 (comp1) > Magnetic Fields (mf) > Domain Coil 1 > Geometry Analysis I** node, then click **Geometry Analysis I**.
- 2 In the **Settings** window for **Geometry Analysis**, click to expand the **Symmetry Specification** section.
- 3 In the  $F_L$  text field, type 4.

#### *Input I*

- 1 In the **Model Builder** window, click **Input I**.
- 2 Select Boundaries 190–192 only.

#### *Geometry Analysis I*

In the **Model Builder** window, click **Geometry Analysis I**.

#### *Output I*

- 1 In the **Physics** toolbar, click  **Attributes** and choose **Output**.
- 2 Select Boundaries 56, 59, and 62 only.

#### *Symmetry Plane I*

- 1 In the **Physics** toolbar, click  **Boundaries** and choose **Symmetry Plane**.
- 2 In the **Settings** window for **Symmetry Plane**, locate the **Boundary Selection** section.
- 3 From the **Selection** list, choose **Symmetry**.

## PRESSURE ACOUSTICS, FREQUENCY DOMAIN (ACPR)

Select the air domains above and under the speaker.

- 1 In the **Model Builder** window, under **Component 1 (comp1)** click **Pressure Acoustics, Frequency Domain (acpr)**.
- 2 In the **Settings** window for **Pressure Acoustics, Frequency Domain**, locate the **Domain Selection** section.
- 3 From the **Selection** list, choose **Air Domain**.

### *Symmetry 1*

- 1 In the **Physics** toolbar, click  **Boundaries** and choose **Symmetry**.
- 2 In the **Settings** window for **Symmetry**, locate the **Boundary Selection** section.
- 3 From the **Selection** list, choose **Symmetry**.

### *Exterior Field Calculation 1*

- 1 In the **Physics** toolbar, click  **Boundaries** and choose **Exterior Field Calculation**.

The exterior-field calculation requires a source boundary encompassing all local sound sources, with a symmetry plane to account for the infinite baffle. After computing the solution, the sound pressure can be evaluated in any point  $(x,y,z)$  outside the domain by entering  $p_{\text{ext}}(x, y, z)$ .
- 2 Select Boundary 10 only.
- 3 In the **Settings** window for **Exterior Field Calculation**, locate the **Exterior Field Calculation** section.
- 4 From the **Symmetry type** list, choose **Sector symmetry with one symmetry plane**.
- 5 From the **Transformation** list, choose **Rotation and reflection**.
- 6 In the  $n$  text field, type 4.

### *Perfectly Matched Boundary 1*

- 1 In the **Physics** toolbar, click  **Boundaries** and choose **Perfectly Matched Boundary**.

Use the **Perfectly Matched Boundary** to model a nonreflecting condition and avoid unphysical reflections (spurious reflections) where the sound leaves the model.
- 2 Select Boundaries 3 and 10 only.

The narrow air gaps around the voice coil have a significant effect on the damping of the back cavity modes, especially, near resonance.

### *Narrow Region Acoustics 1*

- 1 In the **Physics** toolbar, click  **Domains** and choose **Narrow Region Acoustics**.

- 2 Select Domain 23 only.
- 3 In the **Settings** window for **Narrow Region Acoustics**, locate the **Duct Properties** section.
- 4 From the **Duct type** list, choose **Slit**.
- 5 In the  $h$  text field, type `h_slit1`.

#### *Narrow Region Acoustics 2*

- 1 In the **Physics** toolbar, click  **Domains** and choose **Narrow Region Acoustics**.
- 2 Select Domain 6 only.
- 3 In the **Settings** window for **Narrow Region Acoustics**, locate the **Duct Properties** section.
- 4 From the **Duct type** list, choose **Slit**.
- 5 In the  $h$  text field, type `h_slit2`.

#### *Narrow Region Acoustics 3*

- 1 In the **Physics** toolbar, click  **Domains** and choose **Narrow Region Acoustics**.
- 2 Select Domain 12 only.
- 3 In the **Settings** window for **Narrow Region Acoustics**, locate the **Duct Properties** section.
- 4 From the **Duct type** list, choose **Circular duct**.
- 5 In the  $a$  text field, type `1.5[mm]`.

### **SOLID MECHANICS (SOLID)**

- 1 In the **Model Builder** window, under **Component 1 (comp1)** click **Solid Mechanics (solid)**.
- 2 In the **Settings** window for **Solid Mechanics**, locate the **Domain Selection** section.
- 3 Click  **Clear Selection**.
- 4 Select Domains 2, 4, 7–11, 13–18, 20, 22, 24–28, 30, and 31 only.

The magnet, pole piece, and top plate are left out of the above selection. These domains are considered perfectly rigid by using the default sound hard wall condition on their surfaces.

#### *Linear Elastic Material 1*

Add damping to some of the solid materials.

- 1 In the **Model Builder** window, under **Component 1 (comp1)** > **Solid Mechanics (solid)** click **Linear Elastic Material 1**.

#### *Damping 1*



- 1 In the **Physics** toolbar, click  **Attributes** and choose **Damping**.
- 2 In the **Settings** window for **Damping**, locate the **Domain Selection** section.

- 3 Click  **Clear Selection**.
- 4 Select Domains 2, 7–11, 13–15, and 22 only.
- 5 Locate the **Damping Settings** section. From the **Damping type** list, choose **Isotropic loss factor**.

#### *Linear Elastic Material 1*

In the **Model Builder** window, click **Linear Elastic Material 1**.



#### *Damping 2*

- 1 In the **Physics** toolbar, click  **Attributes** and choose **Damping**.
- 2 In the **Settings** window for **Damping**, locate the **Domain Selection** section.
- 3 Click  **Clear Selection**.
- 4 Select Domain 20 only.
- 5 Locate the **Damping Settings** section. In the  $\beta_{dK}$  text field, type  $0.14/\omega_{loss}$ .

#### *Linear Elastic Material 1*

In the **Model Builder** window, click **Linear Elastic Material 1**.

#### *Damping 3*

- 1 In the **Physics** toolbar, click  **Attributes** and choose **Damping**.
- 2 In the **Settings** window for **Damping**, locate the **Domain Selection** section.
- 3 Click  **Clear Selection**.
- 4 Select Domains 28 and 31 only.
- 5 Locate the **Damping Settings** section. In the  $\beta_{dK}$  text field, type  $0.46/\omega_{loss}$ .

#### *Symmetry 1*

- 1 In the **Physics** toolbar, click  **Boundaries** and choose **Symmetry**.
- 2 In the **Settings** window for **Symmetry**, locate the **Boundary Selection** section.
- 3 From the **Selection** list, choose **Symmetry**.

The spider and the surround are attached to the case.

#### *Fixed Constraint 1*

- 1 In the **Physics** toolbar, click  **Boundaries** and choose **Fixed Constraint**.
- 2 Select Boundaries 159 and 168–170 only.

Now is a good time to inspect the **Acoustic-Structure Boundary 1** multiphysics coupling under the **Multiphysics** node. When using a predefined multiphysics interface, the coupling is automatically applied to all acoustic-solid boundaries.

## MULTIPHYSICS

### *Acoustic–Structure Boundary 1 (asb1)*

- 1 In the **Physics** toolbar, click  **Multiphysics Couplings** and choose **Boundary** > **Acoustic–Structure Boundary**.
- 2 In the **Settings** window for **Acoustic–Structure Boundary**, locate the **Boundary Selection** section.
- 3 From the **Selection** list, choose **All boundaries**.

Now, the **Magnetomechanics** multiphysics feature is added to handle the Lorentz force on the coil (it represents the product of the time-harmonic current and the static magnetic field in which it is traveling).

### *Magnetomechanics, Solid 1 (mmcp11)*

- 1 In the **Physics** toolbar, click  **Multiphysics Couplings** and choose **Domain** > **Magnetomechanics, Solid**.
- 2 In the **Settings** window for **Magnetomechanics, Solid**, locate the **Domain Selection** section.
- 3 From the **Selection** list, choose **Coil**.
- 4 Locate the **Lorentz Coupling** section. Select the **Only use Lorentz force** checkbox.

## STUDY 1 - FREQUENCY RESPONSE

- 1 In the **Model Builder** window, click **Study 1**.
- 2 In the **Settings** window for **Study**, type Study 1 - Frequency Response in the **Label** text field.
- 3 Locate the **Study Settings** section. Clear the **Generate default plots** checkbox.

### *Step 1: Coil Geometry Analysis*

- 1 In the **Model Builder** window, under **Study 1 - Frequency Response** click **Step 1: Coil Geometry Analysis**.
- 2 In the **Settings** window for **Coil Geometry Analysis**, locate the **Study Settings** section.
- 3 Clear the **Include geometric nonlinearity** checkbox.

The **Study** node already contains the **Coil Current Calculation** study. Add a **Stationary** study step and disable the Pressure Acoustics and Solid Mechanics interfaces.



### *Step 2: Stationary*

- 1 In the **Study** toolbar, click  **Stationary**.
- 2 In the **Settings** window for **Stationary**, locate the **Physics and Variables Selection** section.

- 3 In the **Solve for** column of the table, under **Component 1 (comp1)**, clear the checkbox for **Solid Mechanics (solid)**.
- 4 In the **Solve for** column of the table, under **Component 1 (comp1) > Multiphysics**, clear the checkbox for **Magnetomechanics, Solid 1 (mmcp11)**.

Add a **Frequency Domain, Perturbation** study step.

*Step 3: Frequency-Domain Perturbation*

- 1 In the **Study** toolbar, click  **More Study Steps** and choose **Frequency Domain > Frequency-Domain Perturbation**.
- 2 In the **Settings** window for **Frequency-Domain Perturbation**, locate the **Study Settings** section.
- 3 Click  **Range**.
- 4 In the **Range** dialog, choose **ISO preferred frequencies** from the **Entry method** list.
- 5 In the **Start frequency** text field, type 20.
- 6 In the **Stop frequency** text field, type  $f_{\max}$ .
- 7 Click **Replace**.

In this model, the mesh is set up manually. Proceed by directly adding the desired mesh component.

## **MESH 1**

The mesh used to compute the impedance needs to resolve the induced eddy currents in the pole piece and the top plate. For the results to be accurate, the skin depth needs to be resolved by at least one, preferably two quadratic elements.

With a conductivity of  $1.12e7$  S/m and a peak relative permeability of 1200, the skin depth in the iron at the maximum frequency of 8 kHz does not go below 0.05 mm. In practice, most of the induced currents will run in regions of the pole piece where the biased relative permeability is much less than 1200, which makes the skin depth greater. In this model, it is therefore sufficient to use a mesh size of 0.5 mm along the iron surfaces that are closest to the voice coil.

For the acoustic-structure interaction, the air domain and the thin moving structures also need to be well resolved. In general, five to six second-order elements per wavelength are needed to resolve the waves. For more details, see *Meshing (Resolving the Waves)* in the *Acoustics Module User's Guide*. In this model, use five elements per wavelength in the acoustic domains.

### *Mapped 1*

In the **Mesh** toolbar, click  **More Generators** and choose **Mapped**.

### *Size*

- 1 In the **Model Builder** window, click **Size**.
- 2 In the **Settings** window for **Size**, locate the **Element Size** section.
- 3 Click the **Custom** button.
- 4 Locate the **Element Size Parameters** section. In the **Maximum element size** text field, type  $343[\text{m/s}] / f_{\text{max}}/5$ .
- 5 In the **Minimum element size** text field, type  $1[\text{mm}]$ .

### *Mapped 1*

- 1 In the **Model Builder** window, click **Mapped 1**.
- 2 Select Boundaries 181, 190–192, 194, and 197 only.

### *Distribution 1*

- 1 In the **Mesh** toolbar, click  **Distribution**.
- 2 Select Edges 288 and 318 only.
- 3 In the **Settings** window for **Distribution**, locate the **Distribution** section.
- 4 In the **Number of elements** text field, type 16.

### *Distribution 2*

- 1 In the **Mesh** toolbar, click  **Distribution**.
- 2 Select Edges 283, 309–311, 313, 317, 320, 321, 330, 331, 371, 372, 377, and 393 only.
- 3 In the **Settings** window for **Distribution**, locate the **Distribution** section.
- 4 In the **Number of elements** text field, type 2.

### *Distribution 3*

- 1 In the **Mesh** toolbar, click  **Distribution**.
- 2 Select Edges 335, 336, 342, 343, 353–356, 364, 365, and 380 only.
- 3 In the **Settings** window for **Distribution**, locate the **Distribution** section.
- 4 In the **Number of elements** text field, type 4.

### *Edge 1*

- 1 In the **Mesh** toolbar, click  **More Generators** and choose **Edge**.
- 2 Select Edges 298, 312, and 314 only.

#### *Distribution 1*

- 1 In the **Mesh** toolbar, click  **Distribution**.
- 2 Select Edge 312 only.
- 3 In the **Settings** window for **Distribution**, locate the **Distribution** section.
- 4 In the **Number of elements** text field, type 3.

#### *Distribution 2*

- 1 In the **Mesh** toolbar, click  **Distribution**.
- 2 Select Edges 286, 298, 302, 314, and 317 only.
- 3 In the **Settings** window for **Distribution**, locate the **Distribution** section.
- 4 In the **Number of elements** text field, type 2.

#### *Mapped 2*

- 1 In the **Mesh** toolbar, click  **More Generators** and choose **Mapped**.
- 2 Select Boundaries 182–185 and 187–189 only.

#### *Distribution 1*

- 1 In the **Mesh** toolbar, click  **Distribution**.
- 2 Select Edge 301 only.
- 3 In the **Settings** window for **Distribution**, locate the **Distribution** section.
- 4 In the **Number of elements** text field, type 6.

#### *Distribution 2*

- 1 In the **Mesh** toolbar, click  **Distribution**.
- 2 Select Edges 285 and 295 only.
- 3 In the **Settings** window for **Distribution**, locate the **Distribution** section.
- 4 In the **Number of elements** text field, type 2.

#### *Swept 1*

- 1 In the **Mesh** toolbar, click  **Swept**.
- 2 In the **Settings** window for **Swept**, locate the **Domain Selection** section.
- 3 From the **Geometric entity level** list, choose **Domain**.
- 4 Select Domains 6–10, 13–18, 20, and 23 only.

#### *Distribution 1*

- 1 In the **Mesh** toolbar, click  **Distribution**.
- 2 Select Domains 6–18, 20, and 23 only.

- 3 In the **Settings** window for **Distribution**, locate the **Distribution** section.
- 4 In the **Number of elements** text field, type 18.

#### *Free Triangular 1*

- 1 In the **Mesh** toolbar, click  **More Generators** and choose **Free Triangular**.
- 2 Select Boundaries 38 and 41 only.

#### *Size 1*

- 1 Right-click **Free Triangular 1** and choose **Size**.
- 2 In the **Settings** window for **Size**, locate the **Element Size** section.
- 3 Click the **Custom** button.
- 4 Locate the **Element Size Parameters** section.
- 5 Select the **Maximum element size** checkbox. In the associated text field, type 3[mm].

#### *Swept 2*

- 1 In the **Mesh** toolbar, click  **Swept**.
- 2 In the **Settings** window for **Swept**, locate the **Domain Selection** section.
- 3 From the **Geometric entity level** list, choose **Domain**.
- 4 Select Domains 11 and 12 only.

#### *Mapped 3*

- 1 In the **Mesh** toolbar, click  **More Generators** and choose **Mapped**.
- 2 Select Boundaries 93, 94, 111, 112, 120–123, 126–129, 137, and 141 only.

#### *Distribution 1*

- 1 In the **Mesh** toolbar, click  **Distribution**.
- 2 Select Edges 328 and 329 only.
- 3 In the **Settings** window for **Distribution**, locate the **Distribution** section.
- 4 In the **Number of elements** text field, type 10.

#### *Distribution 2*

- 1 In the **Mesh** toolbar, click  **Distribution**.
- 2 Select Edges 369 and 370 only.
- 3 In the **Settings** window for **Distribution**, locate the **Distribution** section.
- 4 In the **Number of elements** text field, type 2.

#### *Distribution 3*

- 1 In the **Mesh** toolbar, click  **Distribution**.

- 2 Select Edges 375 and 376 only.
- 3 In the **Settings** window for **Distribution**, locate the **Distribution** section.
- 4 In the **Number of elements** text field, type 3.

#### *Distribution 4*

- 1 In the **Mesh** toolbar, click  **Distribution**.
- 2 Select Edges 358 and 359 only.
- 3 In the **Settings** window for **Distribution**, locate the **Distribution** section.
- 4 In the **Number of elements** text field, type 4.

#### *Distribution 5*

- 1 In the **Mesh** toolbar, click  **Distribution**.
- 2 Select Edge 190 only.
- 3 In the **Settings** window for **Distribution**, locate the **Distribution** section.
- 4 In the **Number of elements** text field, type 18.

#### *Free Triangular 2*

- 1 In the **Mesh** toolbar, click  **More Generators** and choose **Free Triangular**.
- 2 Select Boundaries 9, 78, 140, and 151 only.

#### *Size 1*

- 1 Right-click **Free Triangular 2** and choose **Size**.
- 2 In the **Settings** window for **Size**, locate the **Element Size** section.
- 3 Click the **Custom** button.
- 4 Locate the **Element Size Parameters** section.
- 5 Select the **Maximum element size** checkbox. In the associated text field, type 5[mm].
- 6 Select the **Curvature factor** checkbox. In the associated text field, type 0.4.

#### *Swept 3*

- 1 In the **Mesh** toolbar, click  **Swept**.
- 2 In the **Settings** window for **Swept**, locate the **Domain Selection** section.
- 3 From the **Geometric entity level** list, choose **Domain**.
- 4 Select Domains 2, 22, and 28 only.

#### *Distribution 1*

- 1 In the **Mesh** toolbar, click  **Distribution**.
- 2 In the **Settings** window for **Distribution**, locate the **Distribution** section.

3 In the **Number of elements** text field, type 2.

#### *Mapped 4*

- 1 In the **Mesh** toolbar, click  **More Generators** and choose **Mapped**.
- 2 Select Boundaries 154, 157, 161, 164, and 166 only.

#### *Distribution 1*

- 1 In the **Mesh** toolbar, click  **Distribution**.
- 2 Select Edge 439 only.
- 3 In the **Settings** window for **Distribution**, locate the **Distribution** section.
- 4 In the **Number of elements** text field, type 4.

#### *Distribution 2*

- 1 In the **Mesh** toolbar, click  **Distribution**.
- 2 Select Edges 436 and 441 only.
- 3 In the **Settings** window for **Distribution**, locate the **Distribution** section.
- 4 In the **Number of elements** text field, type 2.

#### *Free Triangular 3*

- 1 In the **Mesh** toolbar, click  **More Generators** and choose **Free Triangular**.
- 2 Select Boundaries 143, 148, 207, 222, and 223 only.

#### *Size 1*

- 1 Right-click **Free Triangular 3** and choose **Size**.
- 2 Select Boundaries 143, 148, and 207 only.
- 3 In the **Settings** window for **Size**, locate the **Element Size** section.
- 4 Click the **Custom** button.
- 5 Locate the **Element Size Parameters** section.
- 6 Select the **Maximum element size** checkbox. In the associated text field, type 6[mm].

#### *Swept 4*

- 1 In the **Mesh** toolbar, click  **Swept**.
- 2 In the **Settings** window for **Swept**, locate the **Domain Selection** section.
- 3 From the **Geometric entity level** list, choose **Domain**.
- 4 Select Domains 30 and 31 only.

#### *Swept 5*

- 1 In the **Mesh** toolbar, click  **Swept**.

- 2 In the **Settings** window for **Swept**, locate the **Domain Selection** section.
- 3 From the **Geometric entity level** list, choose **Domain**.
- 4 Select Domains 27, 29, and 32 only.

#### *Distribution 1*

- 1 In the **Mesh** toolbar, click  **Distribution**.
- 2 In the **Settings** window for **Distribution**, locate the **Distribution** section.
- 3 In the **Number of elements** text field, type 2.

#### *Swept 6*

- 1 In the **Mesh** toolbar, click  **Swept**.
- 2 In the **Settings** window for **Swept**, locate the **Domain Selection** section.
- 3 From the **Geometric entity level** list, choose **Domain**.
- 4 Select Domain 25 only.

#### *Free Triangular 4*

- 1 In the **Mesh** toolbar, click  **More Generators** and choose **Free Triangular**.
- 2 Select Boundaries 174, 198, and 200 only.

#### *Size 1*

- 1 Right-click **Free Triangular 4** and choose **Size**.
- 2 In the **Settings** window for **Size**, locate the **Element Size** section.
- 3 Click the **Custom** button.
- 4 Locate the **Element Size Parameters** section.
- 5 Select the **Maximum element size** checkbox. In the associated text field, type 2[mm].

#### *Boundary Layers 1*

- 1 In the **Mesh** toolbar, click  **Boundary Layers**.
- 2 In the **Settings** window for **Boundary Layers**, locate the **Geometric Entity Selection** section.
- 3 From the **Geometric entity level** list, choose **Boundary**.
- 4 Select Boundaries 174 and 198 only.

#### *Boundary Layer Properties*

- 1 In the **Model Builder** window, click **Boundary Layer Properties**.
- 2 Select Edges 150, 258–260, 276, 278–281, 322–326, 328, 357, and 362 only.
- 3 In the **Settings** window for **Boundary Layer Properties**, locate the **Layers** section.

- 4 In the **Number of layers** text field, type 5.
- 5 In the **Thickness adjustment factor** text field, type 1.1.

#### *Swept 7*

- 1 In the **Mesh** toolbar, click  **Swept**.
- 2 In the **Settings** window for **Swept**, locate the **Domain Selection** section.
- 3 From the **Geometric entity level** list, choose **Domain**.
- 4 Select Domains 4, 24, and 26 only.

#### *Free Tetrahedral 1*

- 1 In the **Mesh** toolbar, click  **Free Tetrahedral**.
- 2 In the **Settings** window for **Free Tetrahedral**, locate the **Domain Selection** section.
- 3 From the **Geometric entity level** list, choose **Domain**.
- 4 Select Domains 1, 3, 5, 19, and 21 only.

#### *Boundary Layers 2*

- 1 In the **Mesh** toolbar, click  **Boundary Layers**.
- 2 In the **Settings** window for **Boundary Layers**, locate the **Geometric Entity Selection** section.
- 3 From the **Geometric entity level** list, choose **Domain**.
- 4 Select Domain 3 only.
- 5 Click to expand the **Transition** section. Clear the **Smooth transition to interior mesh** checkbox.

#### *Boundary Layer Properties*

- 1 In the **Model Builder** window, click **Boundary Layer Properties**.
- 2 Select Boundary 10 only.
- 3 In the **Settings** window for **Boundary Layer Properties**, locate the **Layers** section.
- 4 In the **Number of layers** text field, type 1.



#### *Mapped 1*

In the **Mesh** toolbar, click  **Build Mesh**.

### **STUDY 1 - FREQUENCY RESPONSE**

For the **Frequency Domain, Perturbation** study step, select and enable the suggested iterative solver for a more efficient solver; then **Compute**.

### *Solution 1 (sol1)*

- 1 In the **Study** toolbar, click  **Show Default Solver**.
- 2 In the **Model Builder** window, expand the **Solution 1 (sol1)** node.
- 3 In the **Model Builder** window, expand the **Study 1 - Frequency Response > Solver Configurations > Solution 1 (sol1) > Stationary Solver 3** node.
- 4 Right-click **Study 1 - Frequency Response > Solver Configurations > Solution 1 (sol1) > Stationary Solver 3 > Suggested Iterative Solver (GMRES with GMG) (asbl\_mmcpl1)** and choose **Enable**.
- 5 In the **Study** toolbar, click  **Compute**.

### **ADD STUDY**

- 1 In the **Study** toolbar, click  **Add Study** to open the **Add Study** window.
- 2 Go to the **Add Study** window.

Add an **Eigenfrequency** study to investigate the modal behavior of the mechanical structure of the loudspeaker; then **Compute**. Only the **Solid Mechanics** physics is solved here.
- 3 Find the **Studies** subsection. In the **Select Study** tree, select **Preset Studies for Selected Multiphysics > Eigenfrequency**.
- 4 Click the **Add Study** button in the window toolbar.
- 5 In the **Study** toolbar, click  **Add Study** to close the **Add Study** window.

### **STUDY 2 - STRUCTURAL EIGENMODES**

- 1 In the **Settings** window for **Study**, type Study 2 - Structural Eigenmodes in the **Label** text field.
- 2 Locate the **Study Settings** section. Clear the **Generate default plots** checkbox.

#### *Step 1: Eigenfrequency*

- 1 In the **Model Builder** window, under **Study 2 - Structural Eigenmodes** click **Step 1: Eigenfrequency**.
- 2 In the **Settings** window for **Eigenfrequency**, locate the **Study Settings** section.
- 3 From the **Search method around shift** list, choose **Larger real part**.
- 4 Locate the **Physics and Variables Selection** section. In the **Solve for** column of the table, under **Component 1 (comp1)**, clear the checkboxes for **Magnetic Fields (mf)** and **Pressure Acoustics, Frequency Domain (acpr)**.

- 5 In the **Solve for** column of the table, under **Component 1 (comp1) > Multiphysics**, clear the checkboxes for **Acoustic-Structure Boundary 1 (asb1)** and **Magnetomechanics, Solid 1 (mmcp1)**.
- 6 In the **Study** toolbar, click  **Compute**.

Proceed with creating plots to analyze the results.

## RESULTS

In the **Model Builder** window, expand the **Results** node.

### *Sector 3D 1*

- 1 In the **Model Builder** window, expand the **Results > Datasets** node.
- 2 Right-click **Results > Datasets** and choose **More 3D Datasets > Sector 3D**.  
Use Sector 3D datasets to exploit symmetries in the model.
- 3 In the **Settings** window for **Sector 3D**, locate the **Symmetry** section.
- 4 In the **Number of sectors** text field, type 4.
- 5 From the **Sectors to include** list, choose **Manual**.
- 6 In the **Start sector** text field, type 3.
- 7 In the **Number of sectors to include** text field, type 3.
- 8 From the **Transformation** list, choose **Rotation and reflection**.

### *Sector 3D 2*

- 1 In the **Results** toolbar, click  **More Datasets** and choose **Sector 3D**.
- 2 In the **Settings** window for **Sector 3D**, locate the **Data** section.
- 3 From the **Dataset** list, choose **Study 2 - Structural Eigenmodes/Solution 4 (sol4)**.
- 4 Locate the **Symmetry** section. In the **Number of sectors** text field, type 4.
- 5 From the **Sectors to include** list, choose **Manual**.
- 6 In the **Start sector** text field, type 3.
- 7 In the **Number of sectors to include** text field, type 3.
- 8 From the **Transformation** list, choose **Rotation and reflection**.

### *Geometry*

- 1 In the **Results** toolbar, click  **3D Plot Group**.
- 2 In the **Settings** window for **3D Plot Group**, type **Geometry** in the **Label** text field.
- 3 Locate the **Data** section. From the **Dataset** list, choose **Study 1 - Frequency Response/Solution Store 2 (sol3)**.

- 4 Click to expand the **Title** section. From the **Title type** list, choose **Label**.
- 5 Locate the **Plot Settings** section. Clear the **Plot dataset edges** checkbox.

#### *Volume 1*

- 1 In the **Geometry** toolbar, click  **Volume**.
- 2 In the **Settings** window for **Volume**, locate the **Expression** section.
- 3 In the **Expression** text field, type 1.

#### *Selection 1*

- 1 Right-click **Volume 1** and choose **Selection**.
- 2 Select Domains 25, 27, and 30 only.

#### *Material Appearance 1*

- 1 In the **Model Builder** window, right-click **Volume 1** and choose **Material Appearance**.
- 2 In the **Settings** window for **Material Appearance**, locate the **Appearance** section.
- 3 From the **Appearance** list, choose **Custom**.
- 4 From the **Material type** list, choose **Aluminum**.

#### *Geometry*

In the **Geometry** toolbar, click  **Volume**.

#### *Volume 2*

- 1 In the **Settings** window for **Volume**, locate the **Expression** section.
- 2 In the **Expression** text field, type 1.
- 3 Locate the **Coloring and Style** section. From the **Coloring** list, choose **Uniform**.
- 4 From the **Color** list, choose **Custom**.
- 5 On Windows, click the colored bar underneath, or — if you are running the cross-platform desktop — the **Color** button.
- 6 Click **Define custom colors**.
- 7 Set the RGB values to 42, 49, and 76, respectively.
- 8 Click **Add to custom colors**.
- 9 Click **Show color palette only** or **OK** on the cross-platform desktop.

#### *Selection 1*

- 1 In the **Geometry** toolbar, click  **Selection**.
- 2 Select Domains 2, 22, 28, and 31 only.

### *Material Appearance 1*

- 1 In the **Model Builder** window, right-click **Volume 2** and choose **Material Appearance**.
- 2 In the **Settings** window for **Material Appearance**, locate the **Appearance** section.
- 3 From the **Appearance** list, choose **Custom**.
- 4 From the **Material type** list, choose **Textile**.
- 5 Locate the **Color** section. Select the **Use the plot's color** checkbox.

### *Geometry*

In the **Geometry** toolbar, click  **Volume**.

### *Volume 3*

- 1 In the **Settings** window for **Volume**, locate the **Expression** section.
- 2 In the **Expression** text field, type 1.
- 3 Locate the **Coloring and Style** section. From the **Coloring** list, choose **Uniform**.
- 4 From the **Color** list, choose **Custom**.
- 5 On Windows, click the colored bar underneath, or — if you are running the cross-platform desktop — the **Color** button.
- 6 Click **Define custom colors**.
- 7 Set the RGB values to 196, 106, and 72, respectively.
- 8 Click **Add to custom colors**.
- 9 Click **Show color palette only** or **OK** on the cross-platform desktop.

### *Selection 1*

- 1 In the **Geometry** toolbar, click  **Selection**.
- 2 Select Domain 20 only.

### *Material Appearance 1*

- 1 In the **Model Builder** window, right-click **Volume 3** and choose **Material Appearance**.
- 2 In the **Settings** window for **Material Appearance**, locate the **Appearance** section.
- 3 From the **Appearance** list, choose **Custom**.
- 4 From the **Material type** list, choose **Textile**.
- 5 Locate the **Color** section. Select the **Use the plot's color** checkbox.

### *Geometry*

In the **Geometry** toolbar, click  **Volume**.

#### *Volume 4*

- 1 In the **Settings** window for **Volume**, locate the **Expression** section.
- 2 In the **Expression** text field, type 1.

#### *Selection 1*

- 1 In the **Geometry** toolbar, click  **Selection**.
- 2 Select Domains 7–11 and 13–15 only.

#### *Material Appearance 1*

- 1 In the **Model Builder** window, right-click **Volume 4** and choose **Material Appearance**.
- 2 In the **Settings** window for **Material Appearance**, locate the **Appearance** section.
- 3 From the **Appearance** list, choose **Custom**.
- 4 From the **Material type** list, choose **Chrome**.

#### *Geometry*

In the **Geometry** toolbar, click  **Volume**.

#### *Volume 5*

- 1 In the **Settings** window for **Volume**, locate the **Expression** section.
- 2 In the **Expression** text field, type 1.

#### *Selection 1*

- 1 Right-click **Volume 5** and choose **Selection**.
- 2 In the **Settings** window for **Selection**, locate the **Selection** section.
- 3 From the **Selection** list, choose **Coil**.

#### *Material Appearance 1*

- 1 Right-click **Volume 5** and choose **Material Appearance**.
- 2 In the **Settings** window for **Material Appearance**, locate the **Appearance** section.
- 3 From the **Appearance** list, choose **Custom**.
- 4 From the **Material type** list, choose **Copper**.

#### *Geometry*

In the **Geometry** toolbar, click  **Volume**.

#### *Volume 6*

- 1 In the **Settings** window for **Volume**, locate the **Expression** section.
- 2 In the **Expression** text field, type 1.
- 3 Locate the **Coloring and Style** section. From the **Coloring** list, choose **Uniform**.

- 4 From the **Color** list, choose **Custom**.
- 5 On Windows, click the colored bar underneath, or — if you are running the cross-platform desktop — the **Color** button.
- 6 Click **Define custom colors**.
- 7 Set the RGB values to 167, 176, and 193, respectively.
- 8 Click **Add to custom colors**.
- 9 Click **Show color palette only** or **OK** on the cross-platform desktop.

#### *Selection 1*

- 1 Right-click **Volume 6** and choose **Selection**.
- 2 Select Domains 4 and 24 only.

#### *Material Appearance 1*

- 1 Right-click **Volume 6** and choose **Material Appearance**.
- 2 In the **Settings** window for **Material Appearance**, locate the **Appearance** section.
- 3 From the **Appearance** list, choose **Custom**.
- 4 From the **Material type** list, choose **Iron**.
- 5 Locate the **Color** section. Select the **Use the plot's color** checkbox.

#### *Geometry*

In the **Geometry** toolbar, click  **Volume**.

#### *Volume 7*

- 1 In the **Settings** window for **Volume**, locate the **Expression** section.
- 2 In the **Expression** text field, type 1.
- 3 Locate the **Coloring and Style** section. From the **Coloring** list, choose **Uniform**.
- 4 From the **Color** list, choose **Custom**.
- 5 On Windows, click the colored bar underneath, or — if you are running the cross-platform desktop — the **Color** button.
- 6 Click **Define custom colors**.
- 7 Set the RGB values to 105, 105, and 105, respectively.
- 8 Click **Add to custom colors**.
- 9 Click **Show color palette only** or **OK** on the cross-platform desktop.

#### *Selection 1*

- 1 Right-click **Volume 7** and choose **Selection**.

2 Select Domain 26 only.

### *Material Appearance I*

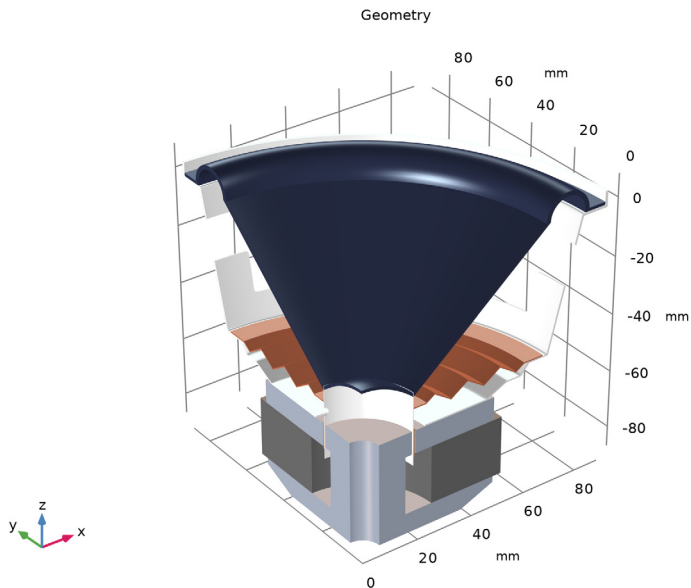

- 1 Right-click **Volume 7** and choose **Material Appearance**.
- 2 In the **Settings** window for **Material Appearance**, locate the **Appearance** section.
- 3 From the **Appearance** list, choose **Custom**.
- 4 From the **Material type** list, choose **Soil**.
- 5 Locate the **Color** section. Select the **Use the plot's color** checkbox.
- 6 In the **Geometry** toolbar, click  **Plot**.



### *Static Magnetic Field*

- 1 In the **Results** toolbar, click  **3D Plot Group**.
- 2 In the **Settings** window for **3D Plot Group**, type **Static Magnetic Field** in the **Label** text field.
- 3 Locate the **Data** section. From the **Dataset** list, choose **Study 1 - Frequency Response/ Solution Store 2 (sol3)**.
- 4 Click to expand the **Title** section. From the **Title type** list, choose **Label**.
- 5 Locate the **Plot Settings** section. Clear the **Plot dataset edges** checkbox.
- 6 Locate the **Color Legend** section. Select the **Show units** checkbox.

### *Streamline I*

- 1 In the **Static Magnetic Field** toolbar, click  **Streamline**.
- 2 In the **Settings** window for **Streamline**, locate the **Streamline Positioning** section.
- 3 In the **Number** text field, type 50.
- 4 Locate the **Selection** section. Click  **Paste Selection**.
- 5 In the **Paste Selection** dialog, type 100 in the **Selection** text field.
- 6 Click **OK**.
- 7 In the **Settings** window for **Streamline**, locate the **Coloring and Style** section.
- 8 Find the **Line style** subsection. From the **Type** list, choose **Tube**.
- 9 In the **Tube radius expression** text field, type 0.2.
- 10 Select the **Radius scale factor** checkbox.

### *Color Expression I*

In the **Static Magnetic Field** toolbar, click  **Color Expression**.

### *Static Magnetic Field*

In the **Static Magnetic Field** toolbar, click  **Volume**.

### *Volume I*

- 1 In the **Settings** window for **Volume**, locate the **Expression** section.
- 2 In the **Expression** text field, type 1.

### *Selection I*

- 1 In the **Static Magnetic Field** toolbar, click  **Selection**.
- 2 In the **Settings** window for **Selection**, locate the **Selection** section.
- 3 From the **Selection** list, choose **Aluminum Domain**.

### *Material Appearance I*

- 1 In the **Model Builder** window, right-click **Volume I** and choose **Material Appearance**.
- 2 In the **Settings** window for **Material Appearance**, locate the **Appearance** section.
- 3 From the **Appearance** list, choose **Custom**.
- 4 From the **Material type** list, choose **Aluminum**.

### *Static Magnetic Field*



In the **Static Magnetic Field** toolbar, click  **Line**.

### *Line I*

- 1 In the **Settings** window for **Line**, locate the **Expression** section.

- 2 In the **Expression** text field, type 1.
- 3 Locate the **Coloring and Style** section. From the **Line type** list, choose **Tube**.
- 4 In the **Tube radius expression** text field, type 0.3.
- 5 Select the **Radius scale factor** checkbox.
- 6 From the **Coloring** list, choose **Uniform**.
- 7 From the **Color** list, choose **Black**.

#### *Selection*

- 1 In the **Static Magnetic Field** toolbar, click  **Selection**.
- 2 In the **Settings** window for **Selection**, locate the **Selection** section.
- 3 Click  **Paste Selection**.
- 4 In the **Paste Selection** dialog, type 12-23, 27, 28, 31-36, 38, 39, 63-67, 69, 70, 92, 93, 95, 96, 102, 103, 106-108, 119-123, 132, 133, 142, 147-151, 153, 154, 159-161, 258-260, 276-279, 282, 284-287, 289, 301-303, 305, 317, 319, 323, 325, 326, 332-334, 352, 357, 360-363, 366 in the **Selection** text field.
- 5 Click **OK**.

#### *Static Magnetic Field*

- 1 In the **Model Builder** window, under **Results** click **Static Magnetic Field**.

- 2 In the **Static Magnetic Field** toolbar, click  **Plot**.

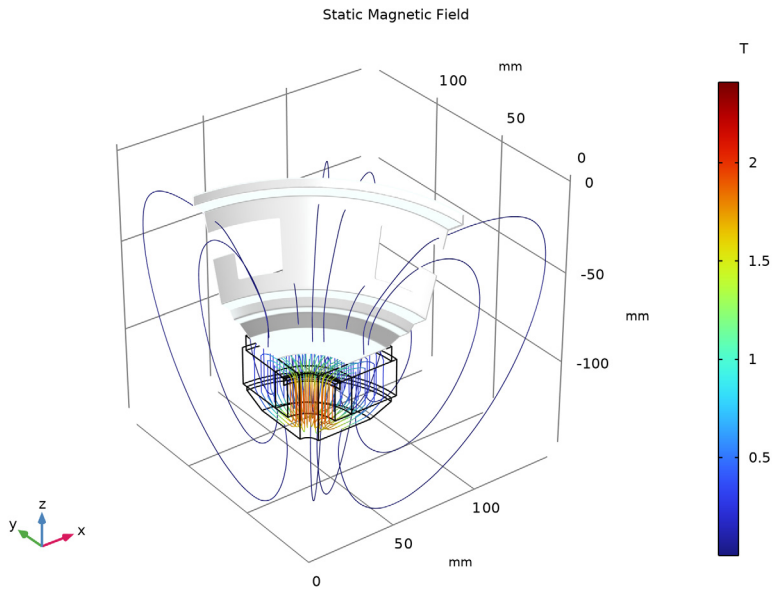



### Current Density

- 1 In the **Home** toolbar, click  **Add Plot Group** and choose **3D Plot Group**.
- 2 In the **Settings** window for **3D Plot Group**, type Current Density in the **Label** text field.
- 3 Locate the **Data** section. From the **Parameter value (freq (Hz))** list, choose **500**.
- 4 Locate the **Color Legend** section. Select the **Show units** checkbox.

### Surface 1

- 1 In the **Current Density** toolbar, click  **Surface**.
- 2 In the **Settings** window for **Surface**, locate the **Expression** section.
- 3 In the **Expression** text field, type `mf.normJ`.
- 4 Locate the **Coloring and Style** section. From the **Color table** list, choose **Dipole**.

### Selection 1

- 1 In the **Current Density** toolbar, click  **Selection**.
- 2 In the **Settings** window for **Selection**, locate the **Selection** section.
- 3 Click  **Paste Selection**.
- 4 In the **Paste Selection** dialog, type 11, 12, 14, 20, 85, 88, 90-92, 94, 110, 112, 132, 174, 190-192, 198, 199, 205 in the **Selection** text field.

5 Click **OK**.

### Current Density

- 1 In the **Model Builder** window, under **Results** click **Current Density**.
- 2 In the **Current Density** toolbar, click  **Plot**.

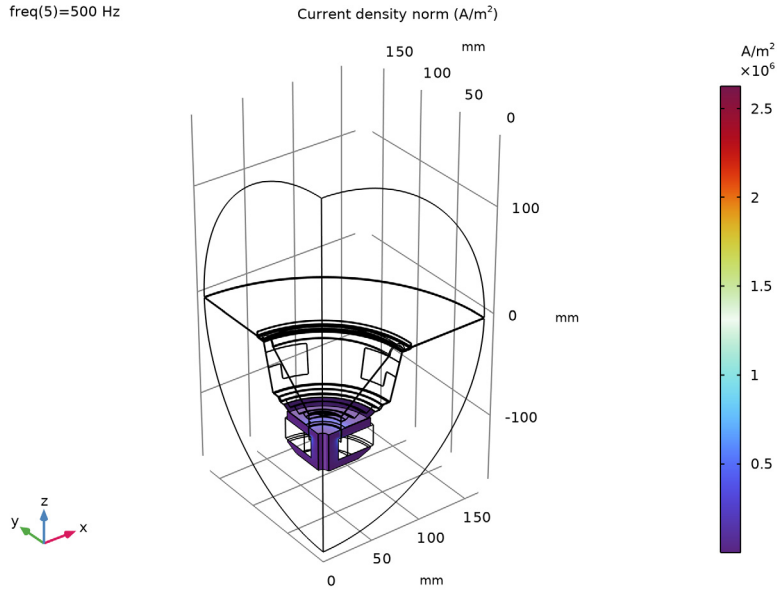

### Acoustic Pressure and SPL

- 1 In the **Results** toolbar, click  **3D Plot Group**.
- 2 In the **Settings** window for **3D Plot Group**, type Acoustic Pressure and SPL in the **Label** text field.
- 3 Locate the **Data** section. From the **Parameter value (freq (Hz))** list, choose **2000**.
- 4 Locate the **Color Legend** section. Select the **Show units** checkbox.

### Surface 1

- 1 In the **Acoustic Pressure and SPL** toolbar, click  **Surface**.
- 2 In the **Settings** window for **Surface**, locate the **Expression** section.
- 3 In the **Expression** text field, type `acpr.p_t`.
- 4 Locate the **Coloring and Style** section. From the **Color table** list, choose **Wave**.
- 5 From the **Scale** list, choose **Linear symmetric**.

### Acoustic Pressure and SPL

In the **Model Builder** window, click **Acoustic Pressure and SPL**.

#### Surface 2

- 1 In the **Acoustic Pressure and SPL** toolbar, click  **Surface**.
- 2 In the **Settings** window for **Surface**, locate the **Expression** section.
- 3 In the **Expression** text field, type `acpr.Lp_t`.

#### Transformation 1

- 1 In the **Acoustic Pressure and SPL** toolbar, click  **More Attributes** and choose **Transformation**.
- 2 In the **Settings** window for **Transformation**, locate the **Transformation** section.
- 3 In the **x** text field, type 300.

### Acoustic Pressure and SPL

- 1 In the **Model Builder** window, under **Results** click **Acoustic Pressure and SPL**.
- 2 In the **Acoustic Pressure and SPL** toolbar, click  **Plot**.

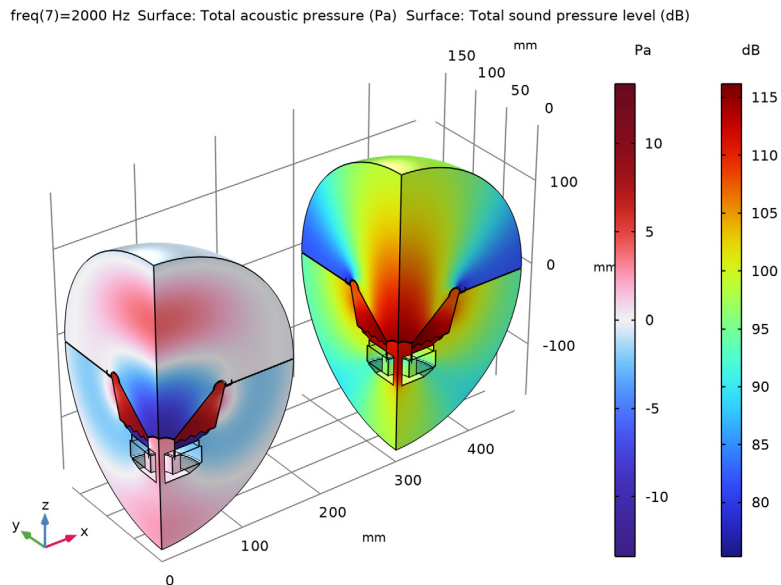

### Displacement

- 1 In the **Results** toolbar, click  **3D Plot Group**.
- 2 In the **Settings** window for **3D Plot Group**, type Displacement in the **Label** text field.

- 3 Locate the **Data** section. From the **Dataset** list, choose **Sector 3D I**.
- 4 From the **Parameter value (freq (Hz))** list, choose **500**.
- 5 Locate the **Color Legend** section. Select the **Show units** checkbox.

#### Surface I

- 1 In the **Displacement** toolbar, click  **Surface**.
- 2 In the **Settings** window for **Surface**, locate the **Expression** section.
- 3 In the **Expression** text field, type `solid.disp`.
- 4 From the **Unit** list, choose  **$\mu\text{m}$** .
- 5 Locate the **Coloring and Style** section. From the **Color table** list, choose **SpectrumLight**.

#### Deformation I

In the **Displacement** toolbar, click  **Deformation**.

#### Displacement

- 1 In the **Model Builder** window, under **Results** click **Displacement**.
- 2 Click  **Plot**.

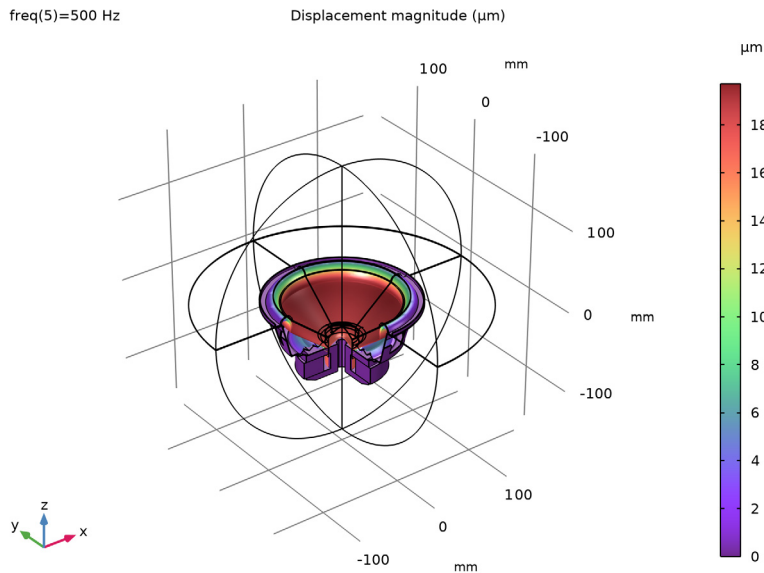

#### Lorentz-Force (z-Component)

- 1 In the **Results** toolbar, click  **3D Plot Group**.

- 2 In the **Settings** window for **3D Plot Group**, type Lorentz-Force (z-Component) in the **Label** text field.
- 3 Locate the **Data** section. From the **Parameter value (freq (Hz))** list, choose **500**.
- 4 Locate the **Color Legend** section. Select the **Show units** checkbox.

#### Volume I

- 1 In the **Lorentz-Force (z-Component)** toolbar, click  **Volume**.
- 2 In the **Settings** window for **Volume**, locate the **Expression** section.
- 3 In the **Expression** text field, type `mmcp11.FLTzz`.
- 4 Select the **Compute differential** checkbox.

#### Lorentz-Force (z-Component)

- 1 In the **Model Builder** window, click **Lorentz-Force (z-Component)**.
- 2 In the **Lorentz-Force (z-Component)** toolbar, click  **Plot**.

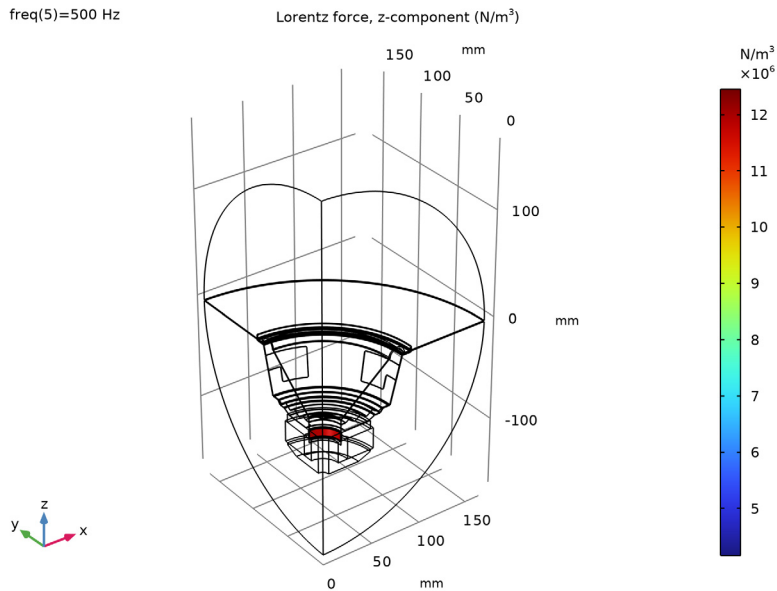

#### Coil Current Density J<sub>x</sub>

- 1 In the **Results** toolbar, click  **3D Plot Group**.
- 2 In the **Settings** window for **3D Plot Group**, type Coil Current Density J<sub>x</sub> in the **Label** text field.
- 3 Locate the **Data** section. From the **Parameter value (freq (Hz))** list, choose **500**.

- 4 Locate the **Color Legend** section. Select the **Show units** checkbox.

#### *Volume I*

- 1 In the **Coil Current Density Jx** toolbar, click  **Volume**.
- 2 In the **Settings** window for **Volume**, locate the **Expression** section.
- 3 In the **Expression** text field, type  $m_f \cdot J_x$ .
- 4 Select the **Compute differential** checkbox.
- 5 Locate the **Coloring and Style** section. From the **Color table** list, choose **Thermal**.

#### *Selection I*

- 1 In the **Coil Current Density Jx** toolbar, click  **Selection**.
- 2 In the **Settings** window for **Selection**, locate the **Selection** section.
- 3 From the **Selection** list, choose **Coil**.

#### *Coil Current Density Jx*

- 1 In the **Model Builder** window, under **Results** click **Coil Current Density Jx**.
- 2 In the **Coil Current Density Jx** toolbar, click  **Plot**.

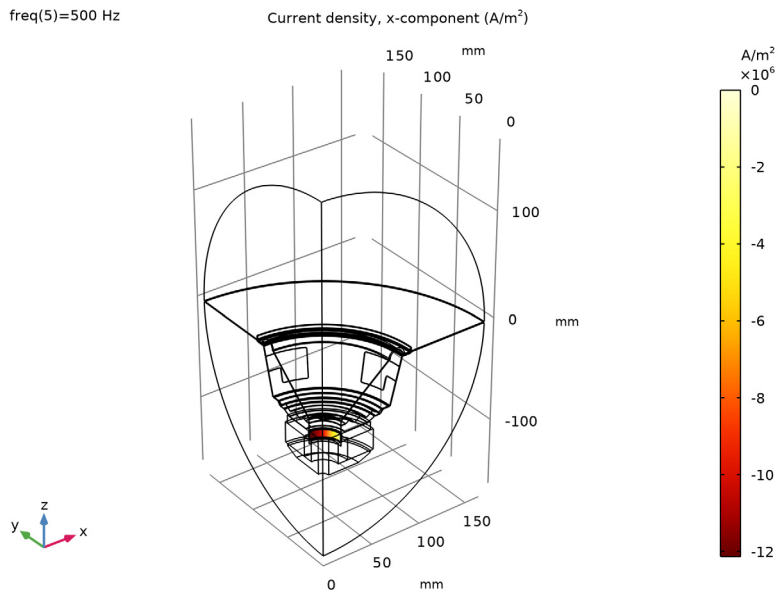

#### *Coil Current Density Jy*

- 1 In the **Results** toolbar, click  **3D Plot Group**.

- 2 In the **Settings** window for **3D Plot Group**, type Coil Current Density  $J_y$  in the **Label** text field.
- 3 Locate the **Data** section. From the **Parameter value (freq (Hz))** list, choose **500**.
- 4 Locate the **Color Legend** section. Select the **Show units** checkbox.

#### Volume 1

- 1 In the **Coil Current Density  $J_y$**  toolbar, click  **Volume**.
- 2 In the **Settings** window for **Volume**, locate the **Expression** section.
- 3 In the **Expression** text field, type  $mf \cdot J_y$ .
- 4 Select the **Compute differential** checkbox.
- 5 Locate the **Coloring and Style** section. From the **Color table** list, choose **Thermal**.

#### Selection 1

- 1 In the **Coil Current Density  $J_y$**  toolbar, click  **Selection**.
- 2 In the **Settings** window for **Selection**, locate the **Selection** section.
- 3 From the **Selection** list, choose **Coil**.

#### Coil Current Density $J_y$

- 1 In the **Model Builder** window, under **Results** click **Coil Current Density  $J_y$** .
- 2 In the **Coil Current Density  $J_y$**  toolbar, click  **Plot**.

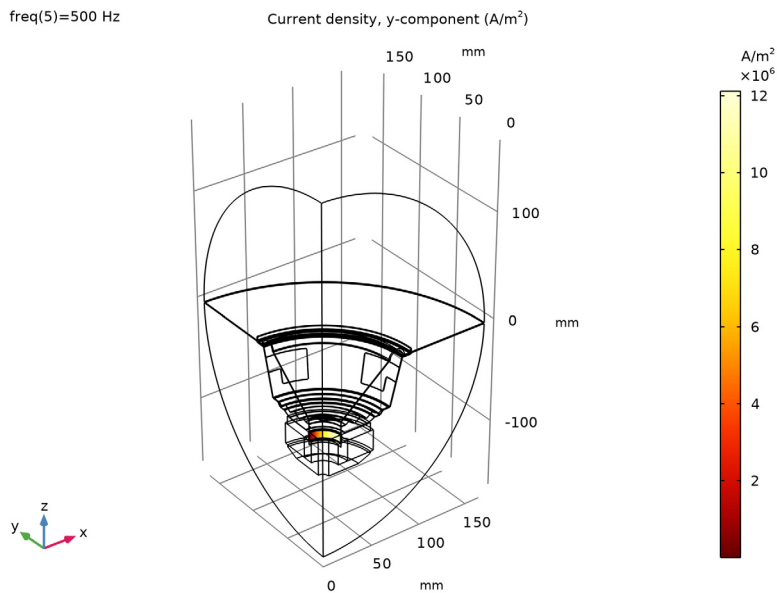

### *On-Axis Response*

- 1 In the **Results** toolbar, click  **ID Plot Group**.
- 2 In the **Settings** window for **ID Plot Group**, type On-Axis Response in the **Label** text field.
- 3 Click to expand the **Title** section. From the **Title type** list, choose **Label**.
- 4 Locate the **Axis** section. Select the **x-axis log scale** checkbox.
- 5 Locate the **Plot Settings** section.
- 6 Select the **x-axis label** checkbox. In the associated text field, type Frequency (Hz).
- 7 Select the **y-axis label** checkbox. In the associated text field, type dB(Z).

### *Octave Band 1*

- 1 In the **On-Axis Response** toolbar, click  **More Plots** and choose **Octave Band**.
- 2 In the **Settings** window for **Octave Band**, locate the **Selection** section.
- 3 From the **Geometric entity level** list, choose **Global**.
- 4 Locate the **y-Axis Data** section. In the **Expression** text field, type `pext(0,0,1[m])`.
- 5 Locate the **Plot** section. From the **Quantity** list, choose **Continuous power spectral density**.

### *On-Axis Response*

- 1 In the **Model Builder** window, click **On-Axis Response**.

- 2 In the **On-Axis Response** toolbar, click  **Plot**.

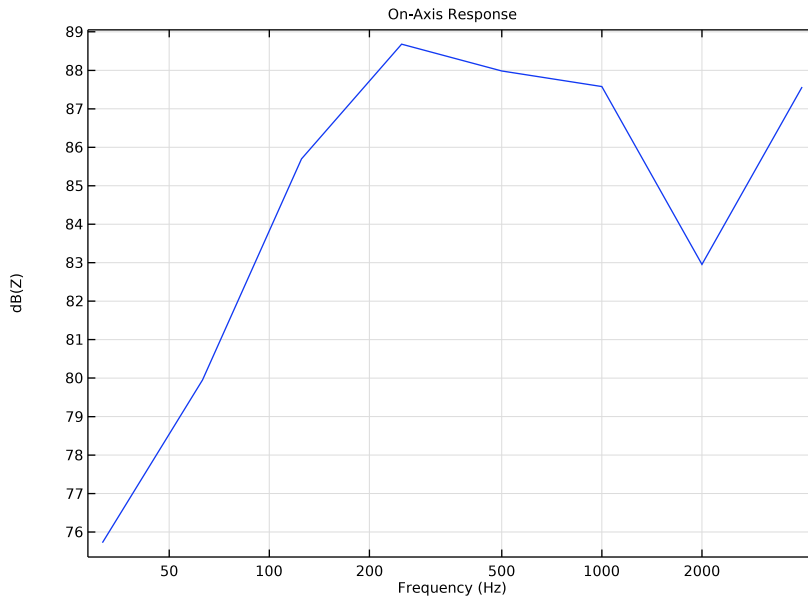

### *Coil Electric Impedance*

- 1 In the **Results** toolbar, click  **ID Plot Group**.
- 2 In the **Settings** window for **ID Plot Group**, type Coil Electric Impedance in the **Label** text field.
- 3 Click to expand the **Title** section. From the **Title type** list, choose **Label**.
- 4 Locate the **Plot Settings** section.
- 5 Select the **x-axis label** checkbox. In the associated text field, type Frequency (Hz).
- 6 Select the **y-axis label** checkbox. In the associated text field, type  $Z(\omega)$ .
- 7 Locate the **Axis** section. Select the **x-axis log scale** checkbox.
- 8 Locate the **Legend** section. From the **Position** list, choose **Upper left**.

### *Global I*

- 1 In the **Coil Electric Impedance** toolbar, click  **Global**.
- 2 In the **Settings** window for **Global**, locate the **y-Axis Data** section.

3 In the table, enter the following settings:

| Expression                    | Unit     | Description          |
|-------------------------------|----------|----------------------|
| <code>abs(mf.ZCoil_1)</code>  | $\Omega$ | <code>abs(Z)</code>  |
| <code>real(mf.ZCoil_1)</code> | $\Omega$ | <code>real(Z)</code> |
| <code>imag(mf.ZCoil_1)</code> | $\Omega$ | <code>imag(Z)</code> |

### Coil Electric Impedance

1 In the **Model Builder** window, click **Coil Electric Impedance**.

2 In the **Coil Electric Impedance** toolbar, click  **Plot**.

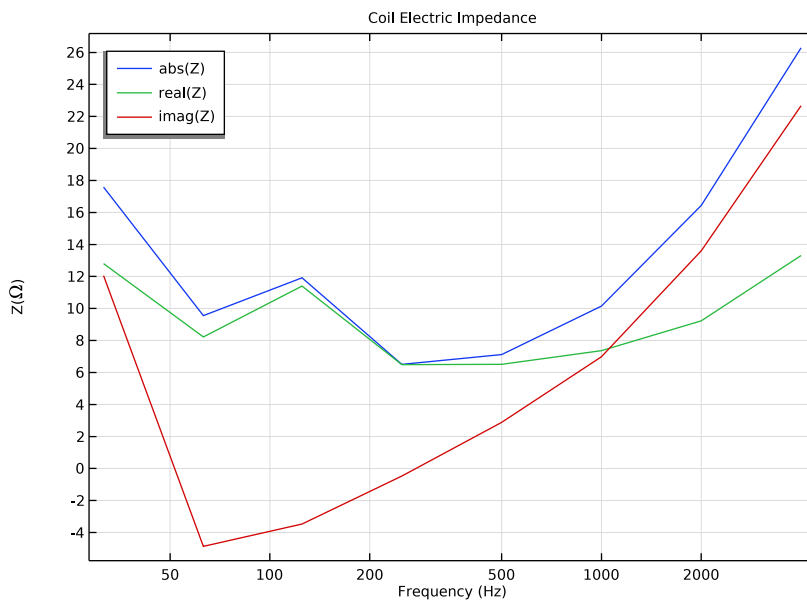

### Spatial Response

1 In the **Results** toolbar, click  **Polar Plot Group**.

2 In the **Settings** window for **Polar Plot Group**, type **Spatial Response** in the **Label** text field.

3 Locate the **Axis** section. From the **Zero angle** list, choose **Up**.

### Radiation Pattern 1

1 In the **Spatial Response** toolbar, click  **More Plots** and choose **Radiation Pattern**.

2 In the **Settings** window for **Radiation Pattern**, locate the **Evaluation** section.

- 3 Find the **Angles** subsection. From the **Restriction** list, choose **Manual**.
- 4 In the  $\phi$  **start** text field, type -90.
- 5 In the  $\phi$  **range** text field, type 180.
- 6 Find the **Normal vector** subsection. In the **x** text field, type 1.
- 7 In the **z** text field, type 0.
- 8 Find the **Evaluation distance** subsection. In the **Radius** text field, type 1 [m].
- 9 Find the **Reference direction** subsection. In the **x** text field, type 0.
- 10 In the **z** text field, type 1.
- 11 Click to expand the **Legends** section. Select the **Show legends** checkbox.

### Spatial Response

- 1 In the **Model Builder** window, click **Spatial Response**.
- 2 In the **Spatial Response** toolbar, click  **Plot**.

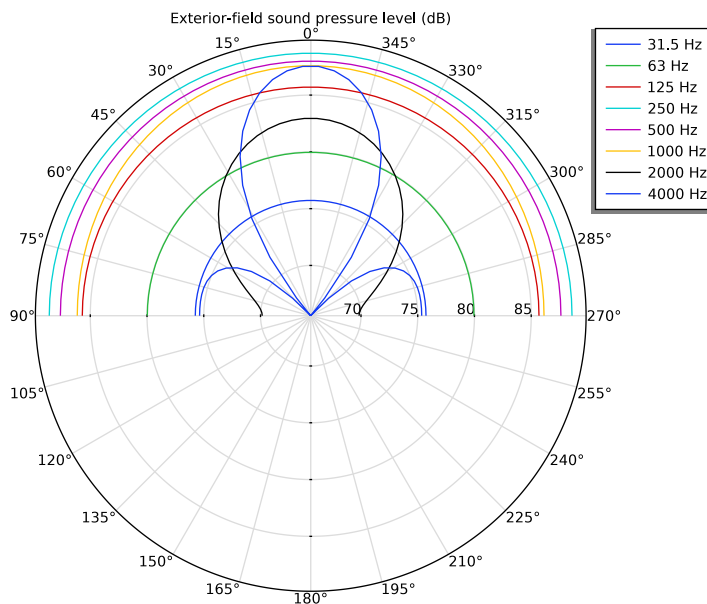

### RESULT TEMPLATES

- 1 In the **Results** toolbar, click  **Result Templates** to open the **Result Templates** window.
- 2 Go to the **Result Templates** window.

- 3 In the tree, select **Study 2 - Structural Eigenmodes/Solution 4 (sol4) > Solid Mechanics > Mode Shape (solid)**.
- 4 Click the **Add Result Template** button in the window toolbar.
- 5 In the **Results** toolbar, click  **Result Templates** to close the **Result Templates** window.

## RESULTS

### *Mode Shape (solid)*

- 1 In the **Settings** window for **3D Plot Group**, locate the **Data** section.
- 2 From the **Dataset** list, choose **Sector 3D 2**.
- 3 From the **Eigenfrequency (Hz)** list, choose **1280+244.4i**.
- 4 In the **Mode Shape (solid)** toolbar, click  **Plot**.

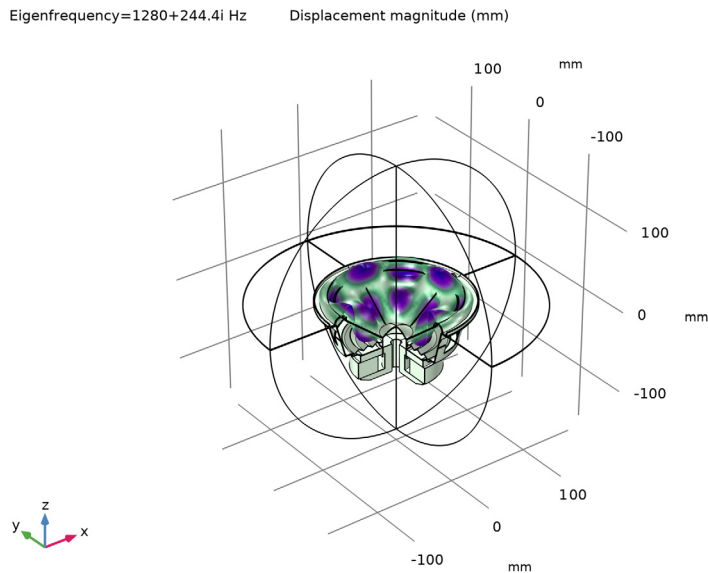

### *Geometry Modeling Instructions*

---

From the **File** menu, choose **New**.

#### **NEW**

In the **New** window, click  **Blank Model**.

The model is created based on a 2D axisymmetric geometry. This simple geometry is transformed through a revolution operation to obtain a 3D geometry, and details are added to model the loudspeaker driver thoroughly.

### ADD COMPONENT

In the **Home** toolbar, click  **Add Component** and choose **3D**.

### GEOMETRY 1

- 1 In the **Settings** window for **Geometry**, locate the **Units** section.
- 2 From the **Length unit** list, choose **mm**.
- 3 Locate the **Advanced** section. From the **Geometry representation** list, choose **CAD kernel**.





*Work Plane 1 (wp1)*

- 1 In the **Geometry** toolbar, click  **Work Plane**.
- 2 In the **Settings** window for **Work Plane**, locate the **Plane Definition** section.
- 3 From the **Plane** list, choose **xz-plane**.



*Work Plane 1 (wp1) > Plane Geometry*

In the **Model Builder** window, click **Plane Geometry**.



*Work Plane 1 (wp1) > Import 1 (imp1)*

- 1 In the **Home** toolbar, click  **Import**.  
Start by importing the 2D geometry.
- 2 In the **Settings** window for **Import**, locate the **Source** section.
- 3 Click  **Browse**.
- 4 Browse to the model's Application Libraries folder and double-click the file `loudspeaker_driver_2d.mphtxt`.
- 5 Click  **Import**.
- 6 Click  **Build Selected**.



*Work Plane 1 (wp1) > Polygon 1 (pol1)*

- 1 In the **Work Plane** toolbar, click  **Polygon**.
- 2 In the **Settings** window for **Polygon**, locate the **Coordinates** section.
- 3 Click  **Load from File**.
- 4 Browse to the model's Application Libraries folder and double-click the file `loudspeaker_driver_3d_polygon1_coordinates.txt`.



*Work Plane 1 (wp1) > Fillet 1 (fil1)*

- 1 In the **Work Plane** toolbar, click  **Fillet**.
- 2 In the **Settings** window for **Fillet**, locate the **Points** section.
- 3 Click the  **Paste Selection** button for **Vertices to fillet**.
- 4 In the **Paste Selection** dialog, type `po11 | 6,7,8,11,12,13` in the **Selection** text field.
- 5 Click **OK**.
- 6 In the **Settings** window for **Fillet**, locate the **Radius** section.
- 7 In the **Radius** text field, type `0.5`.



*Work Plane 1 (wp1) > Fillet 2 (fil2)*

- 1 In the **Work Plane** toolbar, click  **Fillet**.
- 2 In the **Settings** window for **Fillet**, locate the **Points** section.
- 3 Click the  **Paste Selection** button for **Vertices to fillet**.
- 4 In the **Paste Selection** dialog, type `fi11 | 5, 6` in the **Selection** text field.
- 5 Click **OK**.
- 6 In the **Settings** window for **Fillet**, locate the **Radius** section.
- 7 In the **Radius** text field, type `2`.

*Work Plane 1 (wp1) > Fillet 3 (fil3)*

- 1 In the **Work Plane** toolbar, click  **Fillet**.
- 2 In the **Settings** window for **Fillet**, locate the **Points** section.
- 3 Click the  **Paste Selection** button for **Vertices to fillet**.
- 4 In the **Paste Selection** dialog, type `fi12 | 9,10` in the **Selection** text field.
- 5 Click **OK**.
- 6 In the **Settings** window for **Fillet**, locate the **Radius** section.
- 7 In the **Radius** text field, type `1`.



*Work Plane 1 (wp1) > Partition Edges 1 (pare1)*

- 1 In the **Work Plane** toolbar, click  **Booleans and Partitions** and choose **Partition Edges**.
- 2 In the **Settings** window for **Partition Edges**, locate the **Edge Selection** section.
- 3 Click the  **Paste Selection** button for **Edges to partition**.
- 4 In the **Paste Selection** dialog, type `fi13 |13` in the **Selection** text field.
- 5 Click **OK**.
- 6 In the **Settings** window for **Partition Edges**, locate the **Positions** section.



7 In the table, enter the following settings:

| Relative arc length parameters |
|--------------------------------|
| 0.2                            |
| 0.5                            |
| 0.8                            |

*Work Plane 1 (wp1) > Line Segment 1 (ls1)*

- 1 In the **Work Plane** toolbar, click  **More Primitives** and choose **Line Segment**.
- 2 In the **Settings** window for **Line Segment**, locate the **Starting Point** section.
- 3 Click to select the  **Activate Selection** toggle button for **Start vertex**.
- 4 On the object **pare1**, select Point 25 only.
- 5 Locate the **Endpoint** section. Click to select the  **Activate Selection** toggle button for **End vertex**.
- 6 On the object **pare1**, select Point 23 only.

*Work Plane 1 (wp1) > Line Segment 2 (ls2)*

- 1 In the **Work Plane** toolbar, click  **More Primitives** and choose **Line Segment**.
- 2 On the object **pare1**, select Point 13 only.
- 3 In the **Settings** window for **Line Segment**, locate the **Endpoint** section.
- 4 Click to select the  **Activate Selection** toggle button for **End vertex**.
- 5 On the object **pare1**, select Point 14 only.

*Revolve 1 (rev1)*



- 1 In the **Model Builder** window, right-click **Geometry 1** and choose **Revolve**.
- 2 In the **Settings** window for **Revolve**, locate the **Revolution Angles** section.
- 3 Click the **Angles** button.
- 4 In the **End angle** text field, type 90.

*Delete Entities 1 (dell)*



- 1 Right-click **Geometry 1** and choose **Delete Entities**.
- 2 In the **Settings** window for **Delete Entities**, locate the **Entities or Objects to Delete** section.
- 3 From the **Geometric entity level** list, choose **Domain**.
- 4 Click the  **Paste Selection** button for **Selection**.
- 5 In the **Paste Selection** dialog, type rev1 | 1,5 in the **Selection** text field.

6 Click **OK**.

#### *Cap Faces 1 (cap1)*



- 1 In the **Geometry** toolbar, click  **Defeaturing and Repair** and choose **Cap Faces**.
- 2 Click the  **Go to XZ View** button in the **Graphics** toolbar.
- 3 On the object **dell**, select Edges 217, 218, 220, 222, 224, 227, 362–366, and 368 only.

#### *Partition Edges 1 (pare1)*



- 1 In the **Geometry** toolbar, click  **Booleans and Partitions** and choose **Partition Edges**.
- 2 In the **Settings** window for **Partition Edges**, locate the **Edge Selection** section.
- 3 Click the  **Paste Selection** button for **Edges to partition**.
- 4 In the **Paste Selection** dialog, type cap1 | 199, 201, 207 in the **Selection** text field.
- 5 Click **OK**.
- 6 In the **Settings** window for **Partition Edges**, locate the **Positions** section.
- 7 In the table, enter the following settings:

| Relative arc length parameters |
|--------------------------------|
| 0.1                            |
| 0.3                            |
| 0.7                            |
| 0.9                            |



#### *Line Segment 1 (ls1)*

- 1 In the **Geometry** toolbar, click  **More Primitives** and choose **Line Segment**.
- 2 Click the  **Wireframe Rendering** button in the **Graphics** toolbar.
- 3 On the object **pare1**, select Point 199 only.
- 4 In the **Settings** window for **Line Segment**, locate the **Endpoint** section.
- 5 Click to select the  **Activate Selection** toggle button for **End vertex**.
- 6 On the object **pare1**, select Point 201 only.



#### *Line Segment 2 (ls2)*

- 1 In the **Geometry** toolbar, click  **More Primitives** and choose **Line Segment**.
- 2 On the object **pare1**, select Point 188 only.
- 3 In the **Settings** window for **Line Segment**, locate the **Endpoint** section.
- 4 Click to select the  **Activate Selection** toggle button for **End vertex**.
- 5 On the object **pare1**, select Point 198 only.



#### *Line Segment 3 (ls3)*

- 1 In the **Geometry** toolbar, click  **More Primitives** and choose **Line Segment**.
- 2 On the object **pare1**, select Point 111 only.
- 3 In the **Settings** window for **Line Segment**, locate the **Endpoint** section.
- 4 Click to select the  **Activate Selection** toggle button for **End vertex**.
- 5 On the object **pare1**, select Point 112 only.



#### *Line Segment 4 (ls4)*

- 1 In the **Geometry** toolbar, click  **More Primitives** and choose **Line Segment**.
- 2 On the object **pare1**, select Point 154 only.
- 3 In the **Settings** window for **Line Segment**, locate the **Endpoint** section.
- 4 Click to select the  **Activate Selection** toggle button for **End vertex**.
- 5 On the object **pare1**, select Point 158 only.



#### *Union 1 (uni1)*

- 1 In the **Geometry** toolbar, click  **Booleans and Partitions** and choose **Union**.
- 2 In the **Settings** window for **Union**, locate the **Union** section.
- 3 Click the  **Paste Selection** button for **Input objects**.
- 4 In the **Paste Selection** dialog, type **ls1, ls2, ls3, ls4, pare1** in the **Selection** text field.
- 5 Click **OK**.

#### *Extract 1 (extract1)*

- 1 In the **Geometry** toolbar, click  **Extract**.
- 2 In the **Settings** window for **Extract**, locate the **Entities or Objects to Extract** section.
- 3 Click the  **Paste Selection** button for **Selection**.
- 4 In the **Paste Selection** dialog, type **uni1 | 141, 171, 196, 197** in the **Selection** text field.
- 5 Click **OK**.

#### *Thicken 1 (th1)*

- 1 In the **Geometry** toolbar, click  **Conversions** and choose **Thicken**.
- 2 In the **Settings** window for **Thicken**, locate the **Input** section.
- 3 Click the  **Paste Selection** button for **Input objects**.
- 4 In the **Paste Selection** dialog, type **extract1** in the **Selection** text field.
- 5 Click **OK**.
- 6 In the **Settings** window for **Thicken**, locate the **Options** section.

- 7 From the **Offset** list, choose **Asymmetric**.
- 8 In the **Downside thickness** text field, type 2.



#### *Fillet 1 (fil1)*

- 1 In the **Geometry** toolbar, click  **Editing** and choose **Fillet**.
- 2 On the object **thi1**, select Edges 9, 14, 20, 26, 27, 37, 39, and 44 only.
- 3 In the **Settings** window for **Fillet**, locate the **Radius** section.
- 4 In the **Radius** text field, type 1.

#### *Cylinder 1 (cyl1)*

- 1 In the **Geometry** toolbar, click  **Cylinder**.
- 2 In the **Settings** window for **Cylinder**, locate the **Size and Shape** section.
- 3 In the **Radius** text field, type 1.5.
- 4 In the **Height** text field, type 3.
- 5 Locate the **Position** section. In the **y** text field, type 18.
- 6 In the **z** text field, type -48.
- 7 Locate the **Axis** section. From the **Axis type** list, choose **y-axis**.

#### *Intersection 1 (int1)*

- 1 In the **Geometry** toolbar, click  **Booleans and Partitions** and choose **Intersection**.
- 2 In the **Settings** window for **Intersection**, locate the **Intersection** section.
- 3 Click the  **Paste Selection** button for **Input objects**.
- 4 In the **Paste Selection** dialog, type **cy11**, **uni1** in the **Selection** text field.
- 5 Click **OK**.
- 6 In the **Settings** window for **Intersection**, locate the **Intersection** section.
- 7 Select the **Keep input objects** checkbox.

#### *Delete Entities 2 (del2)*

- 1 Right-click **Geometry 1** and choose **Delete Entities**.
- 2 In the **Settings** window for **Delete Entities**, locate the **Entities or Objects to Delete** section.
- 3 From the **Geometric entity level** list, choose **Domain**.
- 4 On the object **cy11**, select Domain 1 only.



#### *Form Union (fin)*

- In the **Geometry** toolbar, click  **Build All**.

#### *Form Composite Domains 1 (cmd1)*

- 1 In the **Geometry** toolbar, click  **Virtual Operations** and choose **Form Composite Domains**.
- 2 On the object **fin**, select Domains 1, 7, 20, 21, 23, 31, and 37 only.

#### *Form Composite Faces 1 (cmf1)*

- 1 In the **Geometry** toolbar, click  **Virtual Operations** and choose **Form Composite Faces**.
- 2 In the **Settings** window for **Form Composite Faces**, locate the **Input** section.
- 3 Click the  **Paste Selection** button for **Faces to composite**.
- 4 In the **Paste Selection** dialog, type 145, 146, 155, 186, 212, 214, 216, 218, 224, 231, 234, 235 in the **Selection** text field.
- 5 Click **OK**.

#### *Form Composite Faces 2 (cmf2)*

- 1 In the **Geometry** toolbar, click  **Virtual Operations** and choose **Form Composite Faces**.
- 2 On the object **cmf1**, select Boundaries 149, 181, 184, 217, 219, and 227 only.

#### *Form Composite Domains 2 (cmd2)*

- 1 In the **Geometry** toolbar, click  **Virtual Operations** and choose **Form Composite Domains**.
- 2 On the object **cmf2**, select Domains 30, 32, and 33 only.