



Model created in COMSOL Multiphysics 6.4

Helmholtz Resonator with Flow: Interaction of Flow and Acoustics

Introduction

Helmholtz resonators are used in exhaust systems as they can attenuate a specific narrow frequency band. The presence of a flow in the system alters the acoustic properties of the resonator and hence the transmission loss of the subsystem. In this model example a Helmholtz resonator is located as a side branch to a main duct. The transmission loss through the main duct is investigated when a mean flow is introduced.

The mean background flow in the system is calculated with the SST turbulence model for Mach numbers $\text{Ma} = 0.05$ and $\text{Ma} = 0.1$. The acoustic problem is then solved using the Linearized Navier–Stokes, Frequency Domain (LNS) physics interface. The mean flow velocity, pressure, and turbulent viscosity are coupled to the LNS model using the Background Fluid Flow Coupling multiphysics feature. The dedicated mapping study is used to interpolate the flow solution from the CFD mesh onto the acoustics mesh. The no-flow case is solved using Pressure Acoustics, Frequency Domain.

The geometry dimensions of the system are taken from those presented in [Ref. 1](#). The results can be compared to the measurements found in the journal paper.

Note: This model requires both the Acoustics Module and the CFD Module.

Model Definition

The geometry and dimensions are the same as the ones presented in [Ref. 1](#). The geometry consists of a main cylindrical duct with a diameter of 4.859 cm and a Helmholtz resonator attached to the side. The resonator has a neck of length 8.05 cm and diameter 4.044 cm. The volume of the resonator is 4501 cm³. The geometry is depicted in [Figure 1](#). The symmetry of the system has been utilized.

The system is filled with air. A mean stationary background flow of average velocity $U_{\text{in}} = c_0 \cdot \text{Ma}$ enters at the left (downstream in the z -axis orientation), where c_0 is the speed of sound. Three flow configurations are studied with $\text{Ma} = 0$ (no flow), $\text{Ma} = 0.05$, and $\text{Ma} = 0.1$.

A plane acoustic wave enters the system downstream. The wave is added as a **Background Acoustics Field** feature in a small domain backed with a perfectly matched layer (PML). In this way, reflected waves are free to leave the computational domain both downstream and upstream. A PML is also added at the upstream outlet. The background plane wave variables are defined according to

$$p_b = 1 \text{ Pa} \cdot e^{-ik_0 z} \quad k_0 = \frac{\omega}{c_0 + U_{\text{in}}}$$

$$\mathbf{u}_b = \left(0, 0, -\frac{1}{i\omega\rho_0} \frac{\partial p_b}{\partial z} \right)$$

$$T_b = \frac{\alpha_p T_0}{\rho_0 C_p} p_b$$

The plane wave expressions are imported into variables in the model. Since the acoustics are solved using the linearized Navier–Stokes equations, perturbations in pressure, velocity, and temperature need to be defined. These are also solved for.

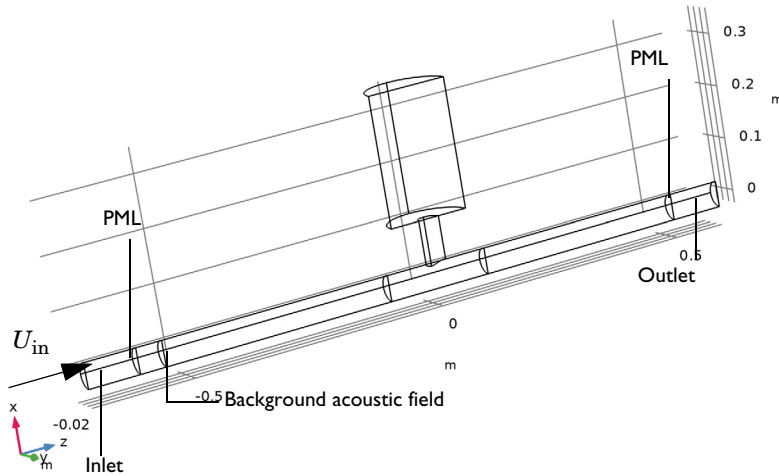

Figure 1: Geometry of the Helmholtz resonator model.

The transmission loss of the system is defined as

$$TL = 20 \log_{10} \left(\frac{1 \text{ Pa}}{p_{\text{out}}} \right)$$

where p_{out} is the average pressure at the outlet and the incident field is defined with an amplitude of 1 Pa.

Two effects are important to capture correctly when analyzing this kind of system. It is the attenuation experience by the acoustic field as it interacts with turbulence (see Ref. 2 and Ref. 3) and the convective effects of the flow and the interaction with the flow gradients.

The two phenomena have opposite effects on the resonance frequency of the system. The additional attenuation due to turbulence will shift the resonance toward a lower frequency while the convective flow effects will shift it to a higher frequency. If the two are not correctly captured the results will be wrong. The transmission loss calculation is a good indicator that this is done correctly; this is seen in [Figure 8](#) below. In order to capture the turbulence attenuation in detail, the SST turbulence model is used for the CFD as it introduces much less numerical diffusion and gives a better prediction of the eddy viscosity. The detailed interaction between flow and acoustics including the extra attenuation can only be modeled using the linearized Navier–Stokes equations as available in the Acoustics Module.

Results and Discussion

The magnitude of the mean background flow velocity is depicted in [Figure 2](#) and the turbulent viscosity is depicted in [Figure 3](#). The value of the turbulent viscosity should be compared to the dynamic viscosity of air $\mu = 2 \cdot 10^{-5}$ Pa·s. At the highest Mach number (depicted in the figure) the resulting experienced viscosity will be a factor 200 larger than the no-flow situation.

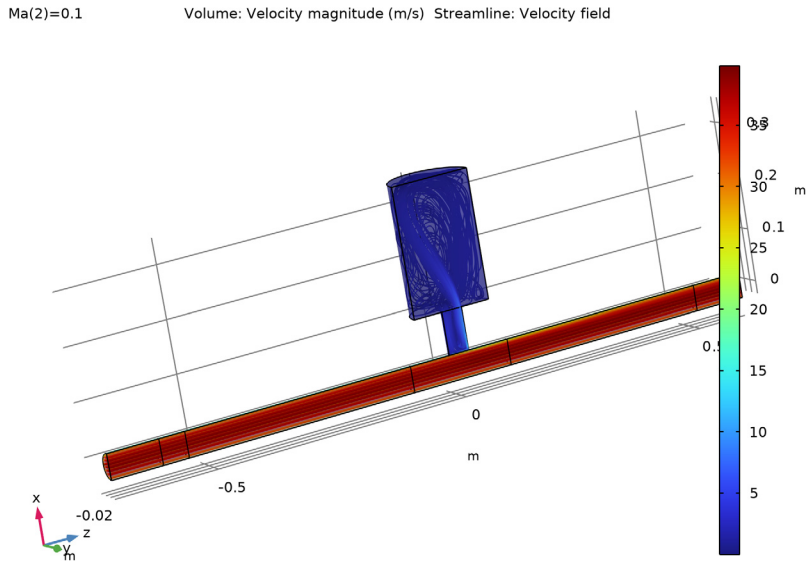

Figure 2: Background mean flow velocity magnitude for $Ma = 0.1$.

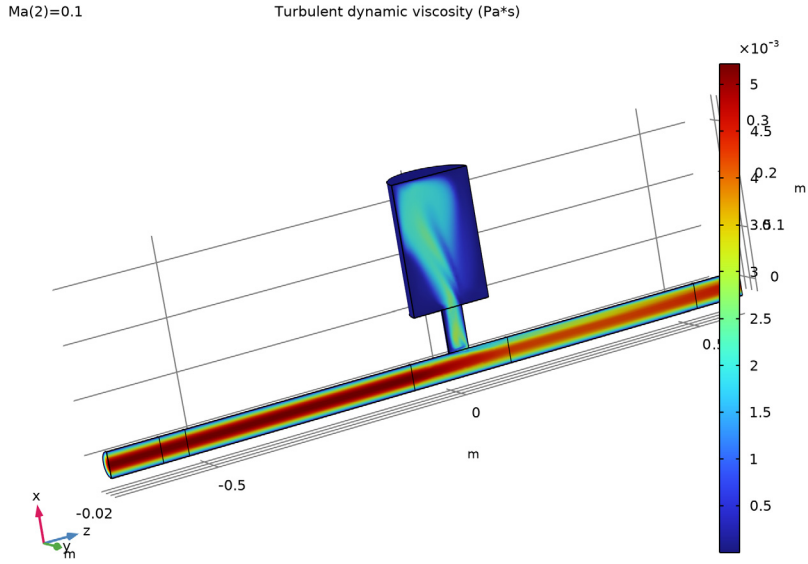

Figure 3: Turbulent viscosity for $Ma = 0.1$.

When the Background Fluid Flow Coupling and the Mapping study is used, it is good practice to visualize the mapped solution and compare it to the original solution on the CFD mesh. In Figure 4 the axial flow velocity and the turbulent viscosity evaluated on the CFD mesh is compared to the mapped values on the acoustics mesh.

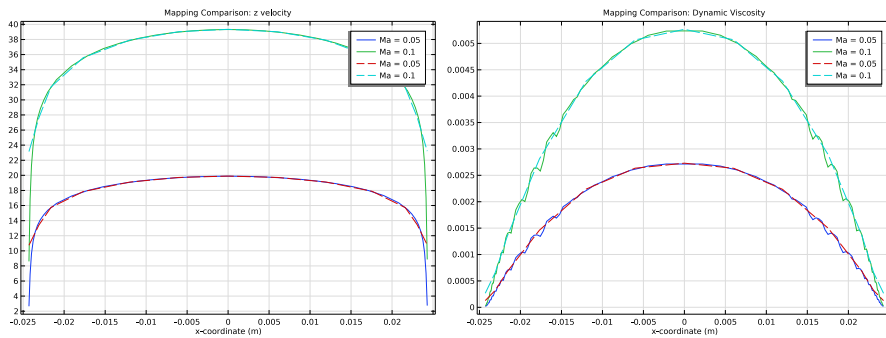

Figure 4: Mapped value of the axial velocity (left) and turbulent viscosity (right) compared to the value as evaluated on the CFD mesh: dashed and solid curves, respectively.

The total acoustic pressure in the system is depicted at 150 Hz for the three cases, no flow in Figure 5, $Ma = 0.05$ in Figure 6, and $Ma = 0.1$ in Figure 7.

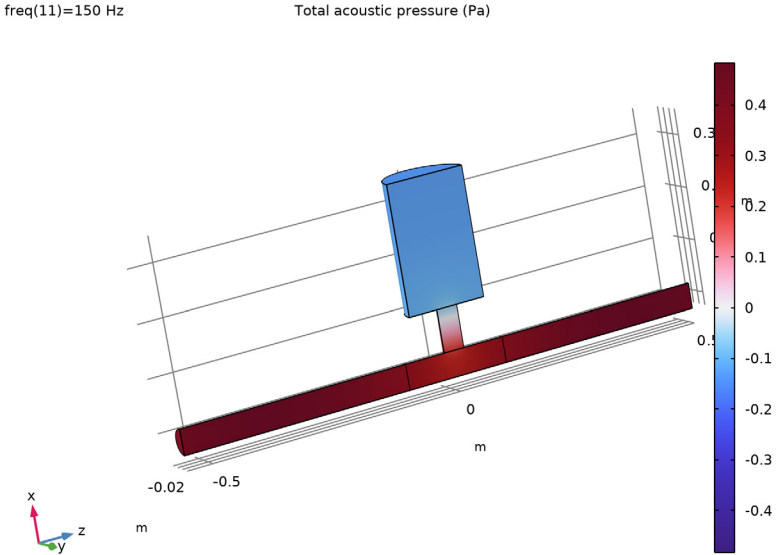

Figure 5: Acoustic pressure in the no flow situation ($Ma = 0$).

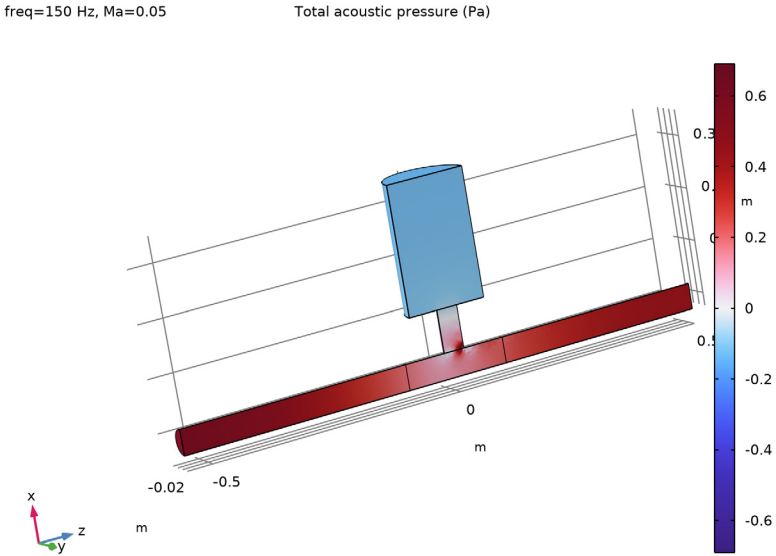

Figure 6: Acoustic pressure for $Ma = 0.05$.

freq=150 Hz, Ma=0.1

Total acoustic pressure (Pa)

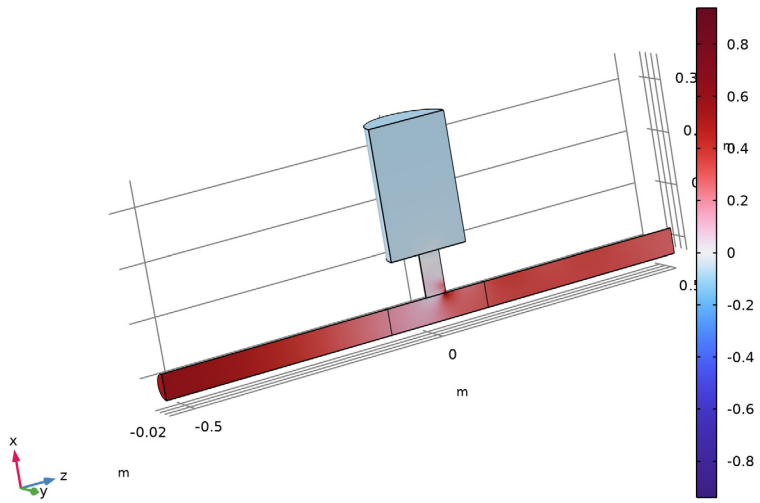

Figure 7: Acoustic pressure for $Ma = 0.1$.

Finally, the transmission loss of the system is depicted in [Figure 8](#). The graph can be compared to measurements performed on the same system presented in [Ref. 1](#). The results show good agreement.

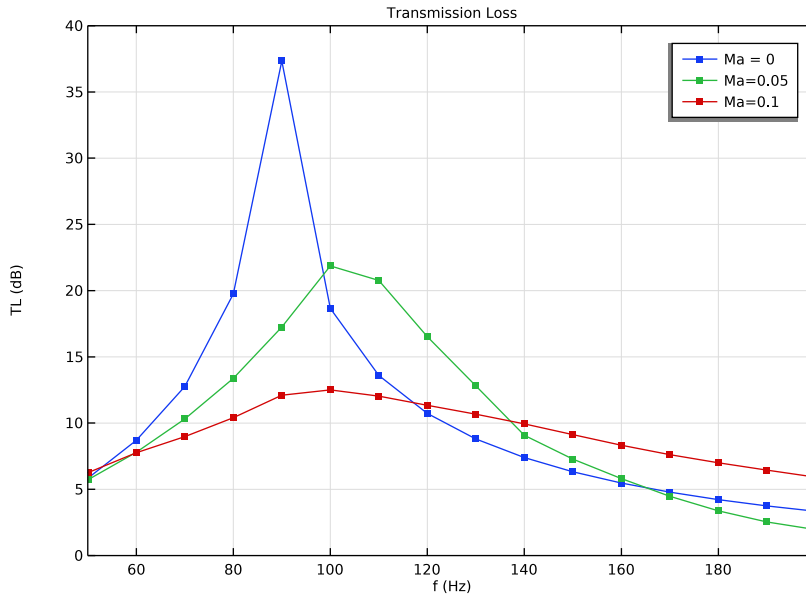

Figure 8: Transmission loss for the three flow configurations.

Notes About the COMSOL Implementation

MAPPING BETWEEN CFD AND ACOUSTICS

The mapping of the fluid flow solution from the CFD mesh to the acoustics mesh is achieved using the built-in Background Fluid Flow Coupling multiphysics feature and the dedicated Mapping study.

CFD MODEL NOTES

It is a common practice to use an already computed CFD solution as the initial solution while incrementing the Mach number, which results in a better convergence of the nonlinear problem. That is, the solution obtained for $Ma = 0.05$ will be used as the initial solution at $Ma = 0.1$ in this model.

This technique is achieved as follows:

- Check the **Auxiliary sweep** checkbox available in the **Study Extensions** section of the corresponding study and specify the desired values of the flow Mach number parameter.
- Choose **No parameter** from the **Run continuation for** list.
- Select **Yes** from the **Reuse solution from previous step** list.

References

1. E. Selamet, A. Selamet, A. Iqbal, and H. Kim, “Effect of Flow in Helmholtz Resonator Acoustics: A Three-Dimensional Computational Study vs. Experiments,” SAE Technical Paper 2011-01-1521, *SAE Int. J.*, 2011.
2. L. Du, A. Holmberg, M. Karlsson, and M. Åbom, “Sound amplification at a rectangular T-junction with merging mean flows,” *J. Sound Vib.*, vol. 367, pp. 69–83 2016.
3. J. Gikadi, S. Föller, and T. Sattelmayer, “Impact of turbulence on the prediction of linear aerodynamic interactions: Acoustic response of a turbulent shear layer,” *J. Sound Vib.*, vol. 333, pp. 6548–6559, 2014.

Application Library path: Acoustics_Module/Aeroacoustics_and_Noise/helmholtz_resonator_with_flow

Modeling Instructions

The following model consists of several steps. First the background mean flow is solved using the CFD Module, then the CFD solution is mapped to the acoustics mesh using the multiphysics coupling and the mapping study, then the acoustics is solved with the mapped flow as input, finally the results are postprocessed.



The first step is to set up the CFD model and solve the flow for two Mach numbers. Running this part of the model can take about 5 h.

From the **File** menu, choose **New**.

NEW

In the **New** window, click  **Model Wizard**.

MODEL WIZARD

- 1 In the **Model Wizard** window, click  **3D**.
- 2 In the **Select Physics** tree, select **Fluid Flow > Single-Phase Flow > Turbulent Flow > Turbulent Flow, SST (spf)**.
- 3 Click **Add**.
- 4 Click  **Study**.
- 5 In the **Select Study** tree, select **Preset Studies for Selected Physics Interfaces > Stationary with Initialization**.
- 6 Click  **Done**.

GLOBAL DEFINITIONS

In the **Model Builder** window, collapse the **Global Definitions** node.

Parameters 1

- 1 In the **Model Builder** window, under **Global Definitions** click **Parameters 1**.
- 2 In the **Settings** window for **Parameters**, locate the **Parameters** section.
- 3 Click  **Load from File**.
- 4 Browse to the model's Application Libraries folder and double-click the file `helmholtz_resonator_with_flow_parameters.txt`.

The first step is to build the geometry of the Helmholtz resonator system. To save time you can **Insert Sequence** from file by referring to the `helmholtz_renoator_with_flow.mph` file in the applications folder of the COMSOL installation.

GEOMETRY 1

Cylinder 1 (cyl1)

- 1 In the **Geometry** toolbar, click  **Cylinder**.
- 2 In the **Settings** window for **Cylinder**, locate the **Size and Shape** section.
- 3 In the **Radius** text field, type $D_{main}/2$.
- 4 In the **Height** text field, type $L_{in}+L_{out}+2*L_{pm1}$.
- 5 Locate the **Position** section. In the **z** text field, type $-L_{in}-L_{pm1}$.
- 6 Click to expand the **Layers** section. In the table, enter the following settings:

Layer name	Thickness (m)
Layer 1	L_{pm1}

- 7 Clear the **Layers on side** checkbox.
- 8 Select the **Layers on bottom** checkbox.
- 9 Select the **Layers on top** checkbox.

Cylinder 2 (cyl2)

- 1 In the **Geometry** toolbar, click  **Cylinder**.
- 2 In the **Settings** window for **Cylinder**, locate the **Size and Shape** section.
- 3 In the **Radius** text field, type $D_{neck}/2$.
- 4 In the **Height** text field, type $1.2*L_{neck}$.
- 5 Locate the **Position** section. In the **x** text field, type $D_{main}/2 - 0.2*L_{neck}$.
- 6 Locate the **Axis** section. From the **Axis type** list, choose **x-axis**.



Cylinder 3 (cyl3)

- 1 In the **Geometry** toolbar, click  **Cylinder**.
- 2 In the **Settings** window for **Cylinder**, locate the **Size and Shape** section.
- 3 In the **Radius** text field, type $D_{reson}/2$.
- 4 In the **Height** text field, type L_{reson} .
- 5 Locate the **Position** section. In the **x** text field, type $D_{main}/2 + L_{neck}$.
- 6 Locate the **Axis** section. From the **Axis type** list, choose **x-axis**.

Cylinder 4 (cyl4)

- 1 In the **Geometry** toolbar, click  **Cylinder**.
- 2 In the **Settings** window for **Cylinder**, locate the **Size and Shape** section.
- 3 In the **Radius** text field, type $D_{main}/2$.
- 4 In the **Height** text field, type L_{source} .
- 5 Locate the **Position** section. In the **z** text field, type $-L_{in}$.

Cylinder 5 (cyl5)

- 1 In the **Geometry** toolbar, click  **Cylinder**.
- 2 In the **Settings** window for **Cylinder**, locate the **Size and Shape** section.
- 3 In the **Radius** text field, type $D_{main}/2$.
- 4 In the **Height** text field, type 0.2 .
- 5 Locate the **Position** section. In the **z** text field, type -0.1 .
- 6 Click  **Build Selected**.

Partition Domains 1 (part 1)

1 In the **Geometry** toolbar, click  **Booleans and Partitions** and choose **Partition Domains**.

2 On the object **cy12**, select Domain 1 only.

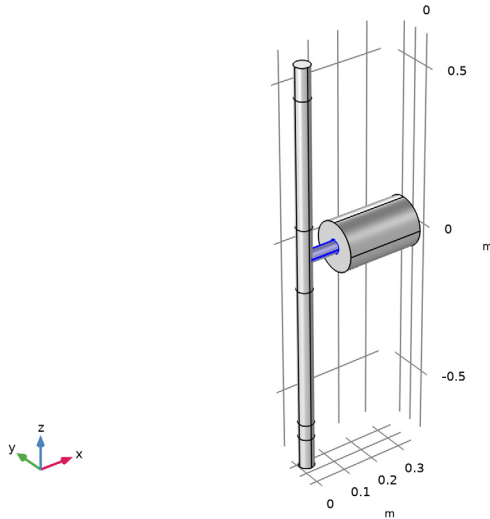

3 In the **Settings** window for **Partition Domains**, locate the **Partition Domains** section.

4 From the **Partition with** list, choose **Extended faces**.

5 On the object **cyll**, select Boundaries 12 and 15 only.

It might be easier to select the boundaries by using the **Selection List** window. To open this window, in the **Home** toolbar click **Windows** and choose **Selection List**. (If you are running the cross-platform desktop, you find **Windows** in the main menu.)

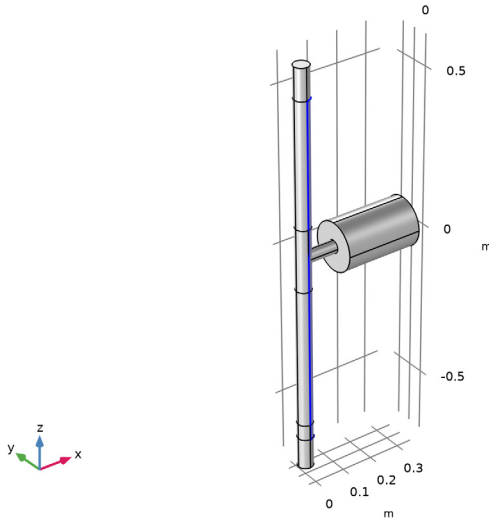

6 From the **Repair tolerance** list, choose **Relative**.

7 Click  **Build All Objects**.

8 Click the  **Wireframe Rendering** button in the **Graphics** toolbar.

Delete Entities 1 (del)

1 In the **Model Builder** window, right-click **Geometry 1** and choose **Delete Entities**.

2 In the **Settings** window for **Delete Entities**, locate the **Entities or Objects to Delete** section.

3 From the **Geometric entity level** list, choose **Domain**.

4 On the object **pard1**, select Domain 1 only.

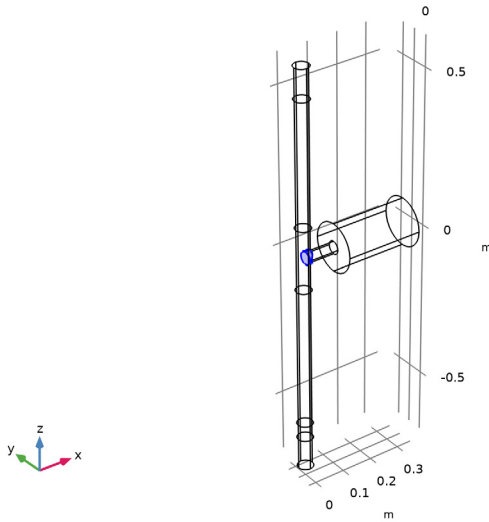

5 Click  **Build Selected**.

Union 1 (uni1)

1 In the **Geometry** toolbar, click  **Booleans and Partitions** and choose **Union**.

2 Click in the **Graphics** window and then press Ctrl+A to select all objects.

Work Plane 1 (wpl1)

1 In the **Geometry** toolbar, click  **Work Plane**.

2 In the **Settings** window for **Work Plane**, locate the **Plane Definition** section.

3 From the **Plane** list, choose **zx-plane**.

Partition Objects 1 (par1)

1 In the **Geometry** toolbar, click  **Booleans and Partitions** and choose **Partition Objects**.

2 Select the object **uni1** only.

3 In the **Settings** window for **Partition Objects**, locate the **Partition Objects** section.

4 From the **Partition with** list, choose **Work plane**.

5 Click  **Build Selected**.

Delete Entities 2 (del2)

1 Right-click **Geometry 1** and choose **Delete Entities**.

- 2 In the **Settings** window for **Delete Entities**, locate the **Entities or Objects to Delete** section.
- 3 From the **Geometric entity level** list, choose **Domain**.
- 4 On the object **par1**, select Domains 2, 4, 6, 8, 10, 12, 14, and 16 only.
- 5 Click  **Build All Objects**.

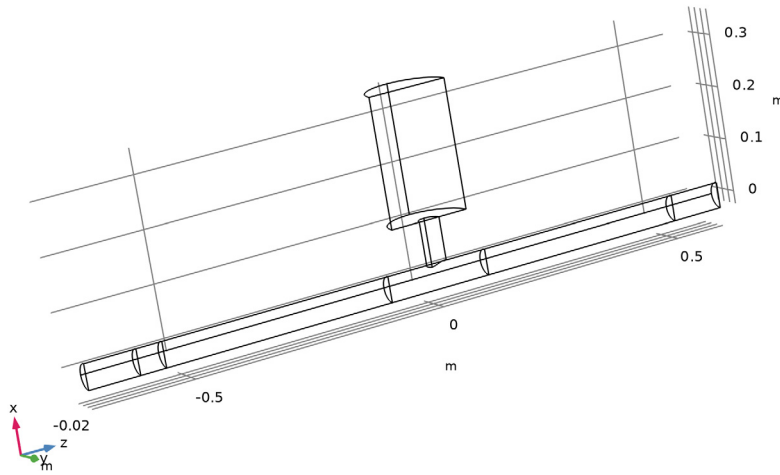

Rotate the geometry in the **Graphics** window. The geometry should look like the figure above.

DEFINITIONS

Symmetry

- 1 In the **Definitions** toolbar, click  **Explicit**.
- 2 In the **Settings** window for **Explicit**, locate the **Input Entities** section.
- 3 From the **Geometric entity level** list, choose **Boundary**.

4 Select Boundaries 2, 5, 8, 11, 14, 17, 29, and 34 only.

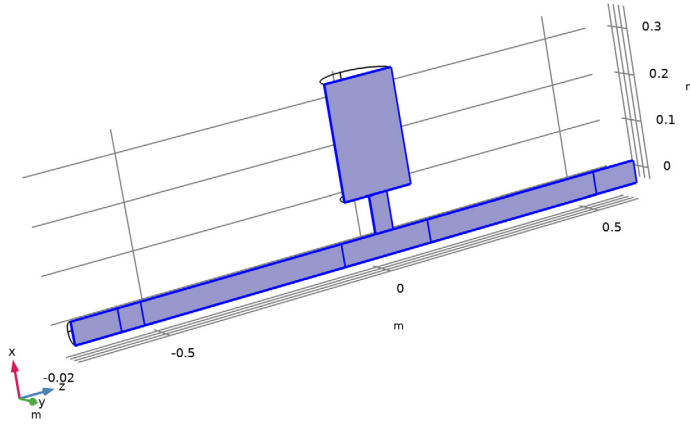

5 In the **Label** text field, type Symmetry.

Walls

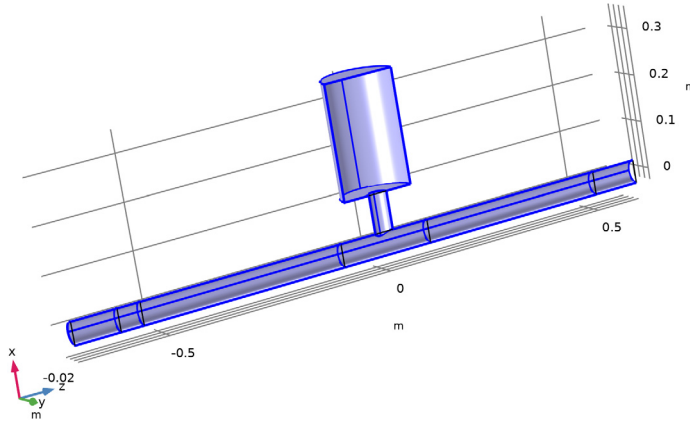

- 1 In the **Definitions** toolbar, click  **Explicit**.
- 2 In the **Settings** window for **Explicit**, locate the **Input Entities** section.
- 3 From the **Geometric entity level** list, choose **Boundary**.

- 4 Select Boundaries 1, 4, 7, 10, 13, 16, 20–25, 27, 28, 30–32, and 35 only.



- 5 In the **Label** text field, type Walls.

ADD MATERIAL

- 1 In the **Materials** toolbar, click  **Add Material** to open the **Add Material** window.
- 2 Go to the **Add Material** window.
- 3 In the tree, select **Built-in** > **Air**.
- 4 Click the **Add to Component** button in the window toolbar.
- 5 In the **Materials** toolbar, click  **Add Material** to close the **Add Material** window.

TURBULENT FLOW, SST (SPF)

- 1 In the **Settings** window for **Turbulent Flow, SST**, locate the **Physical Model** section.
- 2 From the **Compressibility** list, choose **Compressible flow (Ma<0.3)**.

The background flow is now set to be fully compressible. This results in the density to vary spatially. The effects of a nonconstant background density are included in the linearized Navier–Stokes equations. The importance of including this depends on the specific application.

Symmetry 1

- 1 In the **Physics** toolbar, click  **Boundaries** and choose **Symmetry**.
- 2 In the **Settings** window for **Symmetry**, locate the **Boundary Selection** section.

3 From the **Selection** list, choose **Symmetry**.

Outlet 1

1 In the **Physics** toolbar, click  **Boundaries** and choose **Outlet**.

2 Select Boundary 19 only.

Inlet 1

1 In the **Physics** toolbar, click  **Boundaries** and choose **Inlet**.

2 Select Boundary 3 only.

3 In the **Settings** window for **Inlet**, locate the **Boundary Condition** section.

4 From the list, choose **Fully developed flow**.

5 Locate the **Fully Developed Flow** section. In the U_{av} text field, type U_{in} .

This boundary condition ensures a fully developed turbulent flow profile at the inlet.

Generate the mesh used for the CFD simulation. In this model, set up a user-defined mesh consisting of hexahedral elements in the main part of the duct. Such a mesh will give the smallest amount of numerical diffusion. The turbulent viscosity will yield a good estimate of the eddy viscosity used in the acoustics model.

MESH - CFD

1 In the **Model Builder** window, under **Component 1 (comp1)** click **Mesh 1**.

2 In the **Settings** window for **Mesh**, type Mesh - CFD in the **Label** text field.

Free Quad 1

1 In the **Mesh** toolbar, click  **More Generators** and choose **Free Quad**.

2 Select Boundaries 3 and 19 only.

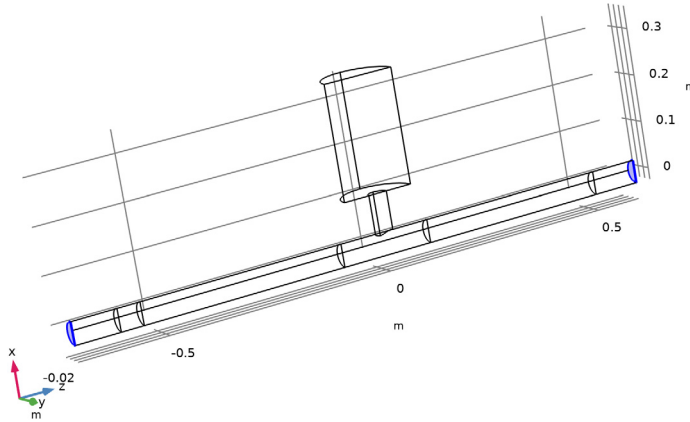

Size 1

- 1 Right-click **Free Quad 1** and choose **Size**.
- 2 In the **Settings** window for **Size**, locate the **Element Size** section.
- 3 From the **Calibrate for** list, choose **Fluid dynamics**.
- 4 From the **Predefined** list, choose **Extremely fine**.

Size

- 1 In the **Model Builder** window, under **Component 1 (comp1) > Mesh - CFD** click **Size**.
- 2 In the **Settings** window for **Size**, locate the **Element Size** section.
- 3 From the **Calibrate for** list, choose **Fluid dynamics**.
- 4 Click the **Custom** button.
- 5 Locate the **Element Size Parameters** section. In the **Maximum element size** text field, type 0.005.
- 6 In the **Minimum element size** text field, type 0.001.
- 7 In the **Maximum element growth rate** text field, type 1.1.
- 8 In the **Curvature factor** text field, type 0.4.
- 9 In the **Resolution of narrow regions** text field, type 1.

Swept 1

- 1 In the **Mesh** toolbar, click  **Swept**.
- 2 In the **Settings** window for **Swept**, locate the **Domain Selection** section.
- 3 From the **Geometric entity level** list, choose **Domain**.
- 4 Select Domains 1 and 2 only.

Distribution 1

- 1 Right-click **Swept 1** and choose **Distribution**.
- 2 Select Domain 1 only.
- 3 In the **Settings** window for **Distribution**, locate the **Distribution** section.
- 4 In the **Number of elements** text field, type 8.

Distribution 2

- 1 In the **Model Builder** window, right-click **Swept 1** and choose **Distribution**.
- 2 Select Domain 2 only.

Swept 2

- 1 In the **Mesh** toolbar, click  **Swept**.
- 2 In the **Settings** window for **Swept**, locate the **Domain Selection** section.
- 3 From the **Geometric entity level** list, choose **Domain**.
- 4 Select Domain 3 only.

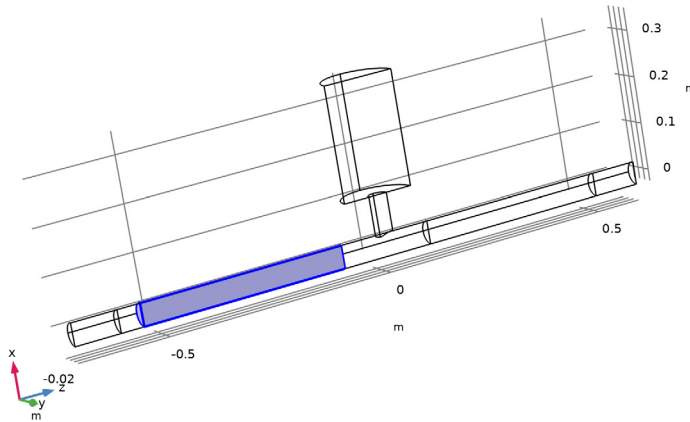

Distribution 1

- 1 Right-click **Swept 2** and choose **Distribution**.
- 2 In the **Settings** window for **Distribution**, locate the **Distribution** section.
- 3 From the **Distribution type** list, choose **Predefined**.
- 4 In the **Number of elements** text field, type 50.
- 5 In the **Element ratio** text field, type 4.
- 6 Select the **Reverse direction** checkbox.

Swept 3

- 1 In the **Mesh** toolbar, click  **Swept**.
- 2 In the **Settings** window for **Swept**, locate the **Domain Selection** section.
- 3 From the **Geometric entity level** list, choose **Domain**.
- 4 Select Domain 6 only.

Distribution 1

- 1 Right-click **Swept 3** and choose **Distribution**.
- 2 In the **Settings** window for **Distribution**, locate the **Distribution** section.
- 3 In the **Number of elements** text field, type 8.

Swept 4

- 1 In the **Mesh** toolbar, click  **Swept**.
- 2 In the **Settings** window for **Swept**, locate the **Domain Selection** section.
- 3 From the **Geometric entity level** list, choose **Domain**.

4 Select Domain 5 only.



Distribution 1

- 1 Right-click **Swept 4** and choose **Distribution**.
- 2 In the **Settings** window for **Distribution**, locate the **Distribution** section.
- 3 From the **Distribution type** list, choose **Predefined**.
- 4 In the **Number of elements** text field, type 50.
- 5 In the **Element ratio** text field, type 4.
- 6 Select the **Reverse direction** checkbox.

Corner Refinement 1

- 1 In the **Mesh** toolbar, click  **More Attributes** and choose **Corner Refinement**.
- 2 In the **Settings** window for **Corner Refinement**, locate the **Boundary Selection** section.
- 3 From the **Selection** list, choose **Walls**.

Free Tetrahedral 1

In the **Mesh** toolbar, click  **Free Tetrahedral**.

Size 1

- 1 Right-click **Free Tetrahedral 1** and choose **Size**.
- 2 In the **Settings** window for **Size**, locate the **Geometric Entity Selection** section.
- 3 From the **Geometric entity level** list, choose **Boundary**.

- 4 Select Boundary 26 only.
- 5 Locate the **Element Size** section. Click the **Custom** button.
- 6 Locate the **Element Size Parameters** section.
- 7 Select the **Maximum element size** checkbox. In the associated text field, type 0.0015.

Boundary Layers I

In the **Mesh** toolbar, click  **Boundary Layers**.

Boundary Layer Properties

- 1 In the **Model Builder** window, click **Boundary Layer Properties**.
- 2 In the **Settings** window for **Boundary Layer Properties**, locate the **Geometric Entity Selection** section.
- 3 From the **Selection** list, choose **Walls**.
- 4 Locate the **Layers** section. In the **Thickness adjustment factor** text field, type 1.4.
- 5 Click  **Build All**.

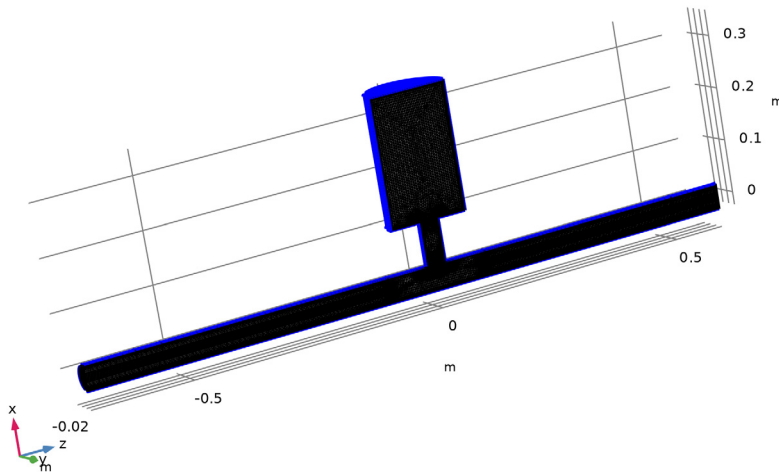

The CFD mesh should look like the figure above.

STUDY I - CFD

- 1 In the **Model Builder** window, click **Study I**.

- 2 In the **Settings** window for **Study**, type Study 1 - CFD in the **Label** text field.
- 3 Locate the **Study Settings** section. Clear the **Generate default plots** checkbox.

Step 2: Stationary

- 1 In the **Model Builder** window, under **Study 1 - CFD** click **Step 2: Stationary**.
- 2 In the **Settings** window for **Stationary**, click to expand the **Study Extensions** section.
- 3 Select the **Auxiliary sweep** checkbox.
- 4 Click **+ Add**.
- 5 In the table, enter the following settings:

Parameter name	Parameter value list	Parameter unit
Ma (Flow Mach number)	0.05 0.1	

Enabling this option ensures that the solution obtained at $Ma = 0.05$ is used as the initial solution for $Ma = 0.1$, which results in a better convergence of the nonlinear solver.

Solution 1 (soll)

- 1 In the **Study** toolbar, click  **Show Default Solver**.
After generating the solver sequence you can inspect the setup and make changes to the defaults if necessary.
Note that solving the model can take 5 h per value of the Mach number parameter (depending on your hardware).
- 2 Click **= Compute**.

RESULTS

Cut Line 3D 1

- 1 In the **Model Builder** window, expand the **Results** node.
- 2 Right-click **Results > Datasets** and choose **Cut Line 3D**.
- 3 In the **Settings** window for **Cut Line 3D**, locate the **Line Data** section.
- 4 In row **Point 1**, set **y** to -0.0001.
- 5 In row **Point 1**, set **z** to -1.
- 6 In row **Point 2**, set **x** to 0.
- 7 In row **Point 2**, set **y** to -0.0001.
- 8 In row **Point 2**, set **z** to 1.

CFD: Velocity

- 1 In the **Results** toolbar, click  **3D Plot Group**.
- 2 In the **Settings** window for **3D Plot Group**, type CFD: Velocity in the **Label** text field.

Volume 1

Right-click **CFD: Velocity** and choose **Volume**.

Transparency 1

In the **Model Builder** window, right-click **Volume 1** and choose **Transparency**.

Streamline 1

- 1 In the **Model Builder** window, right-click **CFD: Velocity** and choose **Streamline**.
- 2 In the **Settings** window for **Streamline**, locate the **Streamline Positioning** section.
- 3 In the **Number** text field, type 50.
- 4 Select Boundaries 12 and 26 only.
- 5 Click to expand the **Inherit Style** section. From the **Plot** list, choose **Volume 1**.

Color Expression 1

- 1 Right-click **Streamline 1** and choose **Color Expression**.
- 2 In the **CFD: Velocity** toolbar, click  **Plot**.
The plot should reproduce [Figure 2](#).

CFD: Turbulent Viscosity

- 1 In the **Results** toolbar, click  **3D Plot Group**.
- 2 In the **Settings** window for **3D Plot Group**, type CFD: Turbulent Viscosity in the **Label** text field.

Surface 1

- 1 Right-click **CFD: Turbulent Viscosity** and choose **Surface**.
- 2 In the **Settings** window for **Surface**, locate the **Expression** section.
- 3 In the **Expression** text field, type $\text{spf} \cdot \mu\text{T}$.
- 4 In the **CFD: Turbulent Viscosity** toolbar, click  **Plot**.
The plot should reproduce [Figure 3](#).

CFD: Turbulent Viscosity Axial

- 1 In the **Results** toolbar, click  **ID Plot Group**.
- 2 In the **Settings** window for **ID Plot Group**, type CFD: Turbulent Viscosity Axial in the **Label** text field.

- 3 Locate the **Data** section. From the **Dataset** list, choose **Cut Line 3D I**.
- 4 Click to expand the **Title** section. From the **Title type** list, choose **Label**.

CFD: Turbulent Viscosity Axial

- 1 Right-click **CFD: Turbulent Viscosity Axial** and choose **Line Graph**.
- 2 In the **Settings** window for **Line Graph**, type *CFD: Turbulent Viscosity Axial* in the **Label** text field.
- 3 Locate the **y-Axis Data** section. In the **Expression** text field, type $\text{spf}.\mu T$.
- 4 Locate the **x-Axis Data** section. From the **Parameter** list, choose **Expression**.
- 5 In the **Expression** text field, type z .
- 6 Click to expand the **Legends** section. Select the **Show legends** checkbox.
- 7 From the **Legends** list, choose **Evaluated**.
- 8 In the **Legend** text field, type $\text{Ma} = \text{eval}(\text{Ma})$.
- 9 In the **CFD: Turbulent Viscosity Axial** toolbar, click  **Plot**.

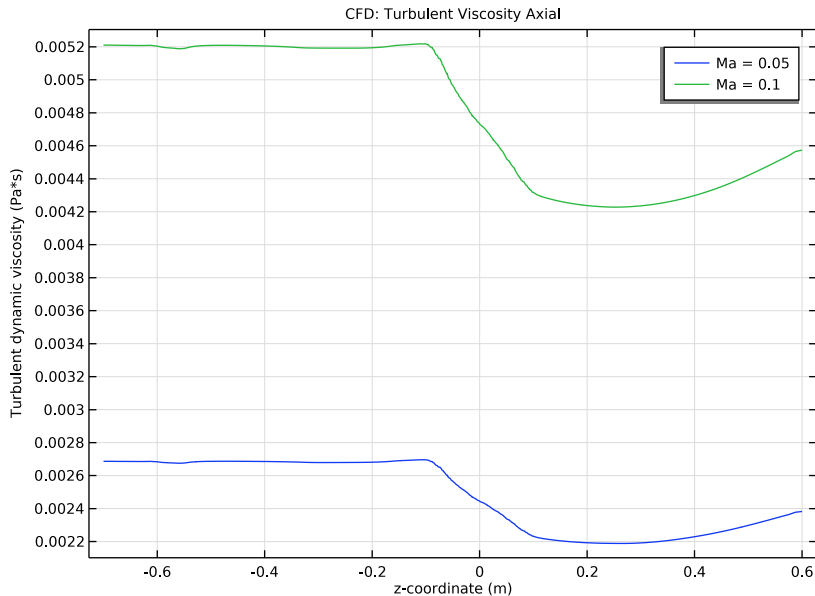



The plot shows the turbulent viscosity along the central axis of the model.

Mapping, Multiphysics, and Acoustics

An important part of solving aeroacoustic problems is to correctly map the CFD solution onto the acoustics domain. This is done using the built-in **Background Fluid Flow Coupling** multiphysics feature and the dedicated **Mapping** study.

First, add the linearized Navier–Stokes interface, then the multiphysics coupling, create a mesh for the acoustics problem, and then compute the mapping study.

ADD PHYSICS

- 1 In the **Home** toolbar, click  **Add Physics** to open the **Add Physics** window.
- 2 Go to the **Add Physics** window.
- 3 In the tree, select **Acoustics** > **Aeroacoustics** > **Linearized Navier–Stokes, Frequency Domain (Insf)**.
- 4 Find the **Physics interfaces in study** subsection. In the table, clear the **Solve** checkbox for **Study 1 - CFD**.
- 5 Click the **Add to Component 1** button in the window toolbar.
- 6 In the **Home** toolbar, click  **Add Physics** to close the **Add Physics** window.

MULTIPHYSICS

Background Fluid Flow Coupling 1 (bffc1)

- 1 In the **Physics** toolbar, click  **Multiphysics Couplings** and choose **Domain** > **Background Fluid Flow Coupling**.
- 2 In the **Settings** window for **Background Fluid Flow Coupling**, locate the **Domain Selection** section.
- 3 From the **Selection** list, choose **All domains**.
- 4 Locate the **Variables to Map** section. Select the **Map the turbulent viscosity** checkbox.

Create the acoustics mesh that the CFD solution is mapped onto. The mesh can be relatively coarse. Note that the finer the mesh the less damping is introduced by the stabilization, this is present to stabilize submesh physical phenomena like vorticity waves. The acoustic boundary layer is not resolved at the walls since slip (and adiabatic) conditions are used there. One or two boundary layer mesh elements is enough to resolve the background flow profile near the wall.

MESH - ACOUSTICS

- 1 In the **Mesh** toolbar, click **Add Mesh** and choose **Add Mesh**.

2 In the **Settings** window for **Mesh**, type Mesh - Acoustics in the **Label** text field.

Free Tetrahedral I

In the **Mesh** toolbar, click  **Free Tetrahedral**.

Size

1 In the **Model Builder** window, click **Size**.

2 In the **Settings** window for **Size**, locate the **Element Size** section.

3 Click the **Custom** button.

4 Locate the **Element Size Parameters** section. In the **Maximum element size** text field, type $D_{main}/8$.

5 In the **Minimum element size** text field, type $D_{main}/15$.

Free Tetrahedral I

1 In the **Model Builder** window, click **Free Tetrahedral I**.

2 In the **Settings** window for **Free Tetrahedral**, locate the **Domain Selection** section.

3 From the **Geometric entity level** list, choose **Domain**.

4 Select Domains 2–5, 7, and 8 only.

Add a **Size** feature to the opening of the resonator, as the flow is likely to have large gradients there.

Size I

1 Right-click **Free Tetrahedral I** and choose **Size**.

2 In the **Settings** window for **Size**, locate the **Geometric Entity Selection** section.

3 From the **Geometric entity level** list, choose **Boundary**.

4 Select Boundary 26 only.

5 Locate the **Element Size** section. Click the **Custom** button.

6 Locate the **Element Size Parameters** section.

7 Select the **Maximum element size** checkbox. In the associated text field, type $D_{main}/15$.

8 Click  **Build Selected**.

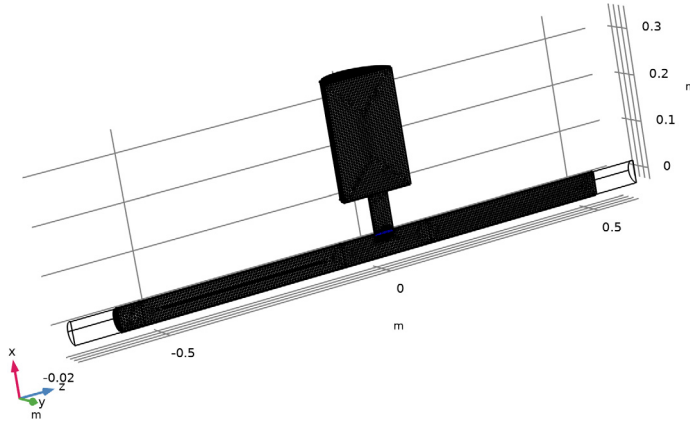

Swept 1

In the **Mesh** toolbar, click  **Swept**.

Distribution 1

- 1 Right-click **Swept 1** and choose **Distribution**.
- 2 In the **Settings** window for **Distribution**, locate the **Distribution** section.
- 3 In the **Number of elements** text field, type 16.
- 4 Click  **Build Selected**.

Boundary Layers 1

- 1 In the **Mesh** toolbar, click  **Boundary Layers**.
- 2 In the **Settings** window for **Boundary Layers**, click to expand the **Transition** section.
- 3 Clear the **Smooth transition to interior mesh** checkbox.

Boundary Layer Properties

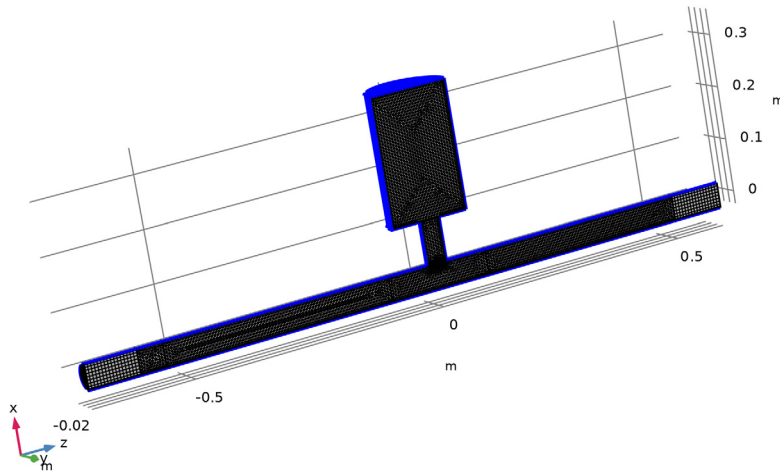

- 1 In the **Model Builder** window, click **Boundary Layer Properties**.
- 2 In the **Settings** window for **Boundary Layer Properties**, locate the **Geometric Entity Selection** section.
- 3 From the **Selection** list, choose **Walls**.
- 4 Locate the **Layers** section. In the **Number of layers** text field, type 2.

- 5 From the **Thickness specification** list, choose **First layer**.
- 6 In the **Thickness** text field, type $D_{main}/40$.
- 7 Click  **Build All**.



The acoustics mesh should look like the figure above.

ADD STUDY

- 1 In the **Home** toolbar, click  **Add Study** to open the **Add Study** window.
- 2 Go to the **Add Study** window.
- 3 Find the **Physics interfaces in study** subsection. In the table, clear the **Solve** checkboxes for **Turbulent Flow**, **SST (spf)** and **Linearized Navier–Stokes, Frequency Domain (Insf)**.
- 4 Find the **Studies** subsection. In the **Select Study** tree, select **Preset Studies for Selected Multiphysics > Mapping**.
- 5 Click the **Add Study** button in the window toolbar.
- 6 In the **Home** toolbar, click  **Add Study** to close the **Add Study** window.

STUDY 2

Step 1: Mapping

- 1 In the **Settings** window for **Mapping**, locate the **Data to Map** section.

- 2 From the **Source** list, choose **Study 1 - CFD, Stationary**.
- 3 From the **Solution** list, choose **Solution 1 (sol1)**.
- 4 From the **Parameter value (Ma)** list, choose **Automatic (all solutions)**.
Expand the **Mesh Selection** section to verify that the destination mesh is selected.
- 5 In the **Model Builder** window, click **Study 2**.
- 6 In the **Settings** window for **Study**, type Study 2 - Mapping in the **Label** text field.
- 7 In the **Study** toolbar, click  **Compute**.

Create two plots that compare the original CFD solution (evaluated on the CFD mesh) with the mapped solution (evaluated on the acoustics mesh).

RESULTS

Mapping Comparison: z velocity

- 1 In the **Results** toolbar, click  **ID Plot Group**.
- 2 In the **Settings** window for **ID Plot Group**, type Mapping Comparison: z velocity in the **Label** text field.
- 3 Locate the **Title** section. From the **Title type** list, choose **Label**.

Line Graph 1

- 1 Right-click **Mapping Comparison: z velocity** and choose **Line Graph**.
- 2 In the **Settings** window for **Line Graph**, locate the **Selection** section.
- 3 Click to select the  **Activate Selection** toggle button.
- 4 Select Edge 12 only.
- 5 Locate the **y-Axis Data** section. In the **Expression** text field, type w .
- 6 Locate the **x-Axis Data** section. From the **Parameter** list, choose **Expression**.
- 7 In the **Expression** text field, type x .
- 8 Locate the **Legends** section. Select the **Show legends** checkbox.
- 9 From the **Legends** list, choose **Evaluated**.
- 10 In the **Legend** text field, type $Ma = \text{eval}(Ma)$.

Line Graph 2

- 1 In the **Model Builder** window, right-click **Mapping Comparison: z velocity** and choose **Line Graph**.
- 2 In the **Settings** window for **Line Graph**, locate the **Data** section.
- 3 From the **Dataset** list, choose **Study 2 - Mapping/Solution 3 (sol3)**.

- 4 Select Edge 12 only.
- 5 Click **Replace Expression** in the upper-right corner of the **y-Axis Data** section. From the menu, choose **Component 1 (comp1) > Background Fluid Flow Coupling 1 > Mapped velocity - m/s > bffcl.u_mapz - Mapped velocity, z-component**.
- 6 Locate the **x-Axis Data** section. From the **Parameter** list, choose **Expression**.
- 7 In the **Expression** text field, type `x`.
- 8 Click to expand the **Coloring and Style** section. Find the **Line style** subsection. From the **Line** list, choose **Dashed**.
- 9 Locate the **Legends** section. Select the **Show legends** checkbox.
- 10 From the **Legends** list, choose **Evaluated**.
- 11 In the **Legend** text field, type `Ma = eval(Ma)`.
- 12 In the **Mapping Comparison: z velocity** toolbar, click  **Plot**.
The plot should reproduce [Figure 4](#) (left).

Mapping Comparison: Dynamic Viscosity

- 1 Right-click **Mapping Comparison: z velocity** and choose **Duplicate**.
- 2 In the **Model Builder** window, click **Mapping Comparison: z velocity 1**.
- 3 In the **Settings** window for **ID Plot Group**, type **Mapping Comparison: Dynamic Viscosity** in the **Label** text field.

Line Graph 1

- 1 In the **Model Builder** window, click **Line Graph 1**.
- 2 In the **Settings** window for **Line Graph**, locate the **y-Axis Data** section.
- 3 In the **Expression** text field, type `spf.mu_eff`.

Line Graph 2

- 1 In the **Model Builder** window, click **Line Graph 2**.
- 2 In the **Settings** window for **Line Graph**, click **Replace Expression** in the upper-right corner of the **y-Axis Data** section. From the menu, choose **Component 1 (comp1) > Background Fluid Flow Coupling 1 > bffcl.mu_eff_map - Mapped turbulent viscosity - Pa·s**.
- 3 In the **Mapping Comparison: Dynamic Viscosity** toolbar, click  **Plot**.
The plot should reproduce [Figure 4](#) (right).

Now set up the acoustics model solving the Linearized Navier–Stokes equations for the background mean flow configuration with $Ma = 0.05$ and $Ma = 0.1$. The no-flow case ($Ma = 0$) is solved using Pressure Acoustics afterward. First, create variables and set up the PMLs.

DEFINITIONS

Variables: Plane Wave

- 1 In the **Model Builder** window, under **Component 1 (comp1)** right-click **Definitions** and choose **Variables**.
- 2 In the **Settings** window for **Variables**, type Variables: Plane Wave in the **Label** text field.
- 3 Locate the **Variables** section. Click  **Load from File**.
- 4 Browse to the model's Application Libraries folder and double-click the file `helmholtz_resonator_with_flow_variables.txt`.
These variables define a plane wave moving in the positive z direction including the effect of a uniform flow. This wave is used as the source of the model.

Integration 1 (intop1)

- 1 In the **Definitions** toolbar, click  **Nonlocal Couplings** and choose **Integration**.
- 2 In the **Settings** window for **Integration**, locate the **Source Selection** section.
- 3 From the **Geometric entity level** list, choose **Boundary**.
- 4 Select Boundary 6 only.
- 5 In the **Operator name** text field, type `intop_in`.

Integration 2 (intop2)

- 1 In the **Definitions** toolbar, click  **Nonlocal Couplings** and choose **Integration**.
- 2 In the **Settings** window for **Integration**, locate the **Source Selection** section.
- 3 From the **Geometric entity level** list, choose **Boundary**.
- 4 Select Boundary 18 only.
- 5 In the **Operator name** text field, type `intop_out`.

Perfectly Matched Layer 1 (pml1)

- 1 In the **Definitions** toolbar, click  **Perfectly Matched Layer**.
- 2 Select Domains 1 and 6 only.

LINEARIZED NAVIER–STOKES, FREQUENCY DOMAIN (LNSF)

Linearized Navier–Stokes Model 1

Inspect, the **Model Input** and **Fluid Properties** sections. Notice that the background mean flow properties are automatically picked up.

Wall 1

- 1 In the **Model Builder** window, click **Wall 1**.
- 2 In the **Settings** window for **Wall**, locate the **Mechanical** section.
- 3 From the **Mechanical condition** list, choose **Slip (perfect)**.
- 4 Locate the **Thermal** section. From the **Thermal condition** list, choose **Adiabatic**.

Symmetry 1

- 1 In the **Physics** toolbar, click  **Boundaries** and choose **Symmetry**.
- 2 In the **Settings** window for **Symmetry**, locate the **Boundary Selection** section.
- 3 From the **Selection** list, choose **Symmetry**.



Background Acoustic Fields 1

- 1 In the **Physics** toolbar, click  **Domains** and choose **Background Acoustic Fields**.
- 2 Select Domain 2 only.
- 3 In the **Settings** window for **Background Acoustic Fields**, locate the **Background Acoustic Fields** section.
- 4 In the p_b text field, type p_b .
- 5 Specify the \mathbf{u}_b vector as

u_b	x
v_b	y
w_b	z

- 6 In the T_b text field, type T_b .

ADD STUDY

- 1 In the **Home** toolbar, click  **Add Study** to open the **Add Study** window.
- 2 Go to the **Add Study** window.
- 3 Find the **Physics interfaces in study** subsection. In the table, clear the **Solve** checkbox for **Turbulent Flow, SST (spf)**.
- 4 Find the **Multiphysics couplings in study** subsection. In the table, clear the **Solve** checkbox for **Background Fluid Flow Coupling 1 (bffcl)**.
- 5 Find the **Studies** subsection. In the **Select Study** tree, select **General Studies > Frequency Domain**.
- 6 Click the **Add Study** button in the window toolbar.
- 7 In the **Home** toolbar, click  **Add Study** to close the **Add Study** window.

STUDY 3

Step 1: Frequency Domain

- 1 In the **Settings** window for **Frequency Domain**, locate the **Study Settings** section.
- 2 In the **Frequencies** text field, type range (50, 10, 200).
- 3 Click to expand the **Values of Dependent Variables** section. Find the **Values of variables not solved for** subsection. From the **Settings** list, choose **User controlled**.
- 4 From the **Method** list, choose **Solution**.
- 5 From the **Study** list, choose **Study 2 - Mapping, Mapping**.
- 6 From the **Parameter value (Ma)** list, choose **Automatic (all solutions)**.
Under the **Mesh Selection** section check that the acoustics mesh is used.
- 7 Click to expand the **Mesh Selection** section. Add an auxiliary sweep to solve for the two Mach numbers.
- 8 Click to expand the **Study Extensions** section. Select the **Auxiliary sweep** checkbox.
- 9 Click **+ Add**.
- 10 In the table, enter the following settings:

Parameter name	Parameter value list	Parameter unit
Ma (Flow Mach number)	0.05 0.1	

- 11 From the **Run continuation for** list, choose **Manual**.
- 12 From the **Continuation parameter** list, choose **freq**.
- 13 In the **Model Builder** window, click **Study 3**.
- 14 In the **Settings** window for **Study**, locate the **Study Settings** section.
- 15 Clear the **Generate default plots** checkbox.
- 16 In the **Label** text field, type Study 3 - Acoustics, Ma = 0.05 and Ma = 0.1.



Solution 4 (sol4)

- 1 In the **Study** toolbar, click  **Show Default Solver**.
- 2 In the **Model Builder** window, expand the **Solution 4 (sol4)** node.
- 3 In the **Model Builder** window, expand the **Study 3 - Acoustics, Ma = 0.05 and Ma = 0.1 > Solver Configurations > Solution 4 (sol4) > Stationary Solver 1** node.
- 4 Right-click **Study 3 - Acoustics, Ma = 0.05 and Ma = 0.1 > Solver Configurations > Solution 4 (sol4) > Stationary Solver 1 > Suggested Iterative Solver (GMRES with Direct Precond.) (Insf)** and choose **Enable**.

5 In the **Study** toolbar, click  **Compute**.

Now, add Pressure Acoustics to model the no-flow case ($Ma = 0$). A background pressure field is also used here to excite the model to simplify postprocessing and get a similar setup as for the linearized Navier–Stokes model. A port condition would normally have been preferred for this waveguide setup.

ADD PHYSICS

- 1 In the **Home** toolbar, click  **Add Physics** to open the **Add Physics** window.
- 2 Go to the **Add Physics** window.
- 3 Find the **Physics interfaces in study** subsection. In the table, clear the **Solve** checkboxes for **Study 1 - CFD**, **Study 2 - Mapping**, and **Study 3 - Acoustics, $Ma = 0.05$ and $Ma = 0.1$** .
- 4 In the tree, select **Acoustics** > **Pressure Acoustics** > **Pressure Acoustics, Frequency Domain (acpr)**.
- 5 Click the **Add to Component 1** button in the window toolbar.
- 6 In the **Home** toolbar, click  **Add Physics** to close the **Add Physics** window.

PRESSURE ACOUSTICS, FREQUENCY DOMAIN (ACPR)

Narrow Region Acoustics 1

- 1 In the **Physics** toolbar, click  **Domains** and choose **Narrow Region Acoustics**.
- 2 Select Domain 7 only.
- 3 In the **Settings** window for **Narrow Region Acoustics**, locate the **Duct Properties** section.
- 4 From the **Duct type** list, choose **Circular duct**.
- 5 In the a text field, type $D_{neck}/2$.



Background Pressure Field 1

- 1 In the **Physics** toolbar, click  **Domains** and choose **Background Pressure Field**.
- 2 Select Domain 2 only.
- 3 In the **Settings** window for **Background Pressure Field**, locate the **Background Pressure Field** section.
- 4 In the p_0 text field, type 1.
- 5 From the c list, choose **From material**.
- 6 Specify the \mathbf{e}_k vector as

0	x
---	---

0	y
1	z

ADD STUDY

- 1 In the **Home** toolbar, click  **Add Study** to open the **Add Study** window.
- 2 Go to the **Add Study** window.
- 3 Find the **Physics interfaces in study** subsection. In the table, clear the **Solve** checkboxes for **Turbulent Flow**, **SST (spf)** and **Linearized Navier–Stokes, Frequency Domain (Insf)**.
- 4 Find the **Multiphysics couplings in study** subsection. In the table, clear the **Solve** checkbox for **Background Fluid Flow Coupling I (bffc1)**.
- 5 Find the **Studies** subsection. In the **Select Study** tree, select **General Studies > Frequency Domain**.
- 6 Click the **Add Study** button in the window toolbar.
- 7 In the **Home** toolbar, click  **Add Study** to close the **Add Study** window.

STUDY 4

Step 1: Frequency Domain

- 1 In the **Settings** window for **Frequency Domain**, locate the **Study Settings** section.
- 2 In the **Frequencies** text field, type range (50, 10, 200).
- 3 In the **Model Builder** window, click **Study 4**.
- 4 In the **Settings** window for **Study**, locate the **Study Settings** section.
- 5 Clear the **Generate default plots** checkbox.
- 6 In the **Label** text field, type Study 4 - Acoustics, $Ma = 0$.
- 7 In the **Study** toolbar, click  **Compute**.

Results

Finally, analyze the acoustic results and compute the transmission loss TL of the model.

RESULTS

Acoustics: Pressure, $Ma = 0$

- 1 In the **Results** toolbar, click  **3D Plot Group**.
- 2 In the **Settings** window for **3D Plot Group**, type Acoustics: Pressure, $Ma = 0$ in the **Label** text field.

- 3 Locate the **Data** section. From the **Dataset** list, choose **Study 4 - Acoustics, Ma = 0/ Solution 5 (sol5)**.
- 4 From the **Parameter value (freq (Hz))** list, choose **150**.
- 5 Click to expand the **Selection** section. From the **Geometric entity level** list, choose **Domain**.
- 6 Select Domains 3–5, 7, and 8 only.
- 7 Select the **Apply to dataset edges** checkbox.

Surface 1

- 1 Right-click **Acoustics: Pressure, Ma = 0** and choose **Surface**.
- 2 In the **Settings** window for **Surface**, locate the **Expression** section.
- 3 In the **Expression** text field, type `acpr.p_t`.
- 4 Locate the **Coloring and Style** section. From the **Color table** list, choose **Wave**.
- 5 From the **Scale** list, choose **Linear symmetric**.
- 6 In the **Acoustics: Pressure, Ma = 0** toolbar, click  **Plot**.
The plot should reproduce [Figure 5](#).

Acoustics: Pressure, Ma = 0.1

- 1 In the **Results** toolbar, click  **3D Plot Group**.
- 2 In the **Settings** window for **3D Plot Group**, type **Acoustics: Pressure, Ma = 0.1** in the **Label** text field.
- 3 Locate the **Data** section. From the **Dataset** list, choose **Study 3 - Acoustics, Ma = 0.05 and Ma = 0.1/Solution 4 (sol4)**.
- 4 From the **Parameter value (freq (Hz))** list, choose **150**.
- 5 Locate the **Selection** section. From the **Geometric entity level** list, choose **Domain**.
- 6 Select Domains 3–5, 7, and 8 only.
- 7 Select the **Apply to dataset edges** checkbox.

Surface 1

- 1 Right-click **Acoustics: Pressure, Ma = 0.1** and choose **Surface**.
- 2 In the **Settings** window for **Surface**, locate the **Expression** section.
- 3 In the **Expression** text field, type `lnsf.p_t`.
- 4 Locate the **Coloring and Style** section. From the **Color table** list, choose **Wave**.
- 5 From the **Scale** list, choose **Linear symmetric**.

6 In the **Acoustics: Pressure, Ma = 0.1** toolbar, click  **Plot**.

The plot should reproduce [Figure 7](#).

Change the Flow Mach number to reproduce the results in [Figure 6](#).

Acoustics: Sound Pressure Level, Ma = 0.05

- 1 Right-click **Surface 1** and choose **Duplicate**.
- 2 In the **Model Builder** window, click **Acoustics: Pressure, Ma = 0.1.1**.
- 3 In the **Settings** window for **3D Plot Group**, type **Acoustics: Sound Pressure Level, Ma = 0.05** in the **Label** text field.
- 4 Locate the **Data** section. From the **Parameter value (Ma)** list, choose **0.05**.

Surface 1

- 1 In the **Model Builder** window, click **Surface 1**.
- 2 In the **Settings** window for **Surface**, locate the **Expression** section.
- 3 In the **Expression** text field, type $\text{Im}sf.Lp$.
- 4 Locate the **Coloring and Style** section. From the **Color table** list, choose **Rainbow**.
- 5 From the **Scale** list, choose **Linear**.
- 6 Click to expand the **Quality** section. From the **Evaluation settings** list, choose **Manual**.
- 7 From the **Resolution** list, choose **Finer**.
- 8 In the **Acoustics: Sound Pressure Level, Ma = 0.05** toolbar, click  **Plot**.

Transmission Loss

- 1 In the **Results** toolbar, click  **ID Plot Group**.
- 2 In the **Settings** window for **ID Plot Group**, type **Transmission Loss** in the **Label** text field.
- 3 Locate the **Data** section. From the **Dataset** list, choose **None**.
- 4 Locate the **Title** section. From the **Title type** list, choose **Label**.
- 5 Locate the **Plot Settings** section.
- 6 Select the **x-axis label** checkbox. In the associated text field, type f (Hz).
- 7 Select the **y-axis label** checkbox. In the associated text field, type TL (dB).
- 8 Locate the **Axis** section. Select the **Manual axis limits** checkbox.
- 9 In the **y minimum** text field, type 0.
- 10 In the **y maximum** text field, type 40.
- 11 In the **x minimum** text field, type 50.

12 In the **x maximum** text field, type 200.

Global 1

- 1 Right-click **Transmission Loss** and choose **Global**.
- 2 In the **Settings** window for **Global**, locate the **Data** section.
- 3 From the **Dataset** list, choose **Study 4 - Acoustics, Ma = 0/Solution 5 (sol5)**.
- 4 Locate the **y-Axis Data** section. In the table, enter the following settings:

Expression	Unit	Description
$20 \cdot \log_{10}(\text{abs}(\text{intop_in}(1[\text{Pa}]) / \text{intop_out}(\text{acpr.p_t})))$		Ma = 0

- 5 Click to expand the **Coloring and Style** section. Find the **Line markers** subsection. From the **Marker** list, choose **Point**.

Global 2

- 1 In the **Model Builder** window, right-click **Transmission Loss** and choose **Global**.
- 2 In the **Settings** window for **Global**, locate the **Data** section.
- 3 From the **Dataset** list, choose **Study 3 - Acoustics, Ma = 0.05 and Ma = 0.1/Solution 4 (sol4)**.
- 4 Locate the **y-Axis Data** section. In the table, enter the following settings:

Expression	Unit	Description
$20 \cdot \log_{10}(\text{abs}(\text{intop_in}(\text{pb}) / \text{intop_out}(\text{lnsf.p_t})))$		

- 5 Locate the **x-Axis Data** section. From the **Axis source data** list, choose **freq**.
- 6 Locate the **Coloring and Style** section. Find the **Line markers** subsection. From the **Marker** list, choose **Point**.

The plot should reproduce [Figure 8](#).

The last thing to do is to disable the PMLs in the CFD study. This is to make sure that, if the study is solved again then the results will be correct. The CFD interface is not supported inside domains with PMLs.

STUDY 1 - CFD

Step 1: Wall Distance Initialization

- 1 In the **Model Builder** window, under **Study 1 - CFD** click **Step 1: Wall Distance Initialization**.

- 2 In the **Settings** window for **Wall Distance Initialization**, locate the **Physics and Variables Selection** section.
- 3 Select the **Modify model configuration for study step** checkbox.
- 4 In the tree, select **Component 1 (comp1) > Definitions > Artificial Domains > Perfectly Matched Layer 1 (pml1)**.
- 5 Right-click and choose **Disable**.

Step 2: Stationary

- 1 In the **Model Builder** window, click **Step 2: Stationary**.
- 2 In the **Settings** window for **Stationary**, locate the **Physics and Variables Selection** section.
- 3 Select the **Modify model configuration for study step** checkbox.
- 4 In the tree, select **Component 1 (comp1) > Definitions > Artificial Domains > Perfectly Matched Layer 1 (pml1)**.
- 5 Right-click and choose **Disable**.