



Model created in COMSOL Multiphysics 6.4

# Headphone on an Artificial Ear

## *Introduction*

---

In this tutorial a headphone is simulated in a typical measurement setup. As headphones are closely coupled to the ear, it is not representative to measure their sensitivity in an acoustic free-field in the classical setup used for loudspeakers. The measurement requires the use of artificial heads and ears to accurately represent the usage conditions. This model shows the coupling of a circumaural headphone to a generic artificial ear.

To model all components in a headphone, this tutorial uses several physics and features. The foam is modeled with the *Poroelastic Waves* interface and coupled to *Pressure Acoustics, Frequency Domain* interface for the air domains. The *Interior Perforated Plate* condition is used to model the perforated plates and meshes in the headphone casing. The artificial ear is coupled to a simplified ear canal and the impedance of the ear drum is specifically considered in the model. The dynamic speaker driver is modeled through a lumped approach following [Ref. 1](#).

Lumped representations of drivers are well known and widely used in the industry. The parameters that characterize the low-frequency performance of a loudspeaker, commonly known as the Thiele–Small or the small-signal parameters, are obtained from [Ref. 2](#). This lumped model is coupled to the 3D pressure acoustics model describing the surrounding air domain using the *Interior Lumped Speaker Boundary* condition.

---

**Note:** Many of the working principles of the lumped speaker model are described in the [Lumped Loudspeaker Driver](#) model. Application Library path `Acoustics_Module/Electroacoustic_Transducers/lumped_loudspeaker_driver`.

---

## *Model Definition*

---

### **GEOMETRY**

A schematic section of the model is shown in [Figure 2](#). The pinna (peach color) is obtained from a 3D scan of an actual human ear. The ear canal has been idealized as a cylinder of 7.5 mm diameter and 19.8 mm length. The pinna and ear canal have been rotated to maintain the headphone oriented in global coordinates. The acoustic domain is shown in three regions; the pressure chamber (blue) the external domain (light blue) and the perfectly matched layer domain (dark blue). The driver is included in the model as its lumped equivalent (Electrical Circuit interface) enforcing a velocity on the diaphragm (yellow line). The pressure drop across the diaphragm is coupled back to the circuit. The

different chambers of the acoustic domain are connected through perforated plates (green lines). The headphone casing (gray) is considered as rigid (the model can be extended to model the casing as an elastic structure). The foam (red) is a Poroelastic Waves domain completely fixed on the boundaries attached to the skin and the headphone casing.

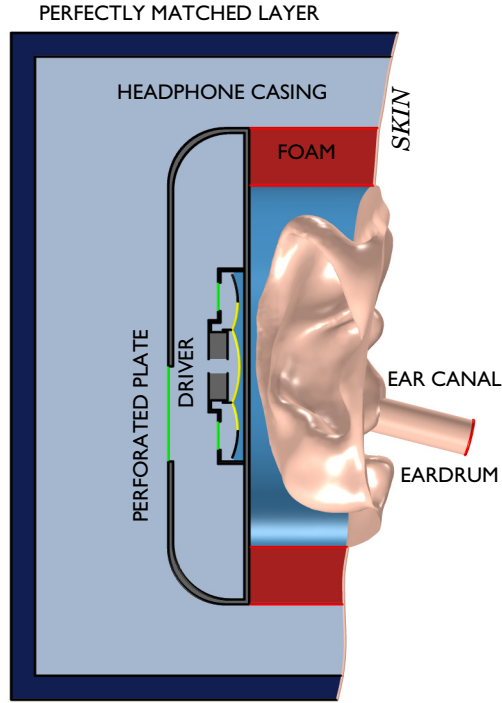

Figure 1: Schematic representation of the model.

### PARAMETERS

The model parameters are given in the table below. The speeds defined in the table are used exclusively for the definition of the mesh size in the different domains. The value of 272 m/s is the speed of the fast pressure waves in the poroelastic waves (PELW) domain. The maximum mesh size  $h_{\max}$  is in general given by

$$h_{\max} = \frac{1}{5} \frac{\min(c_i)}{f}$$

where  $c_i$  represents all the wave speed present in a model and  $f$  is the frequency. In a pure fluid there is just one speed of sound. By using the speed of the fast pressure waves in the PELW domain, we will be under-resolving the slow pressure waves and the shear waves in

the PELW domain. This is done here to reduce the model size when solving the tutorial model. Ideally, the mesh should consider the minimum of the pressure waves speeds (variables `pelw.cp_fast` and `pelw.cp_slow`) and shear waves (variable `pelw.cs_poro`) in the PELW domain.

TABLE 1: MODEL PARAMETERS.

VARIABLE	VALUE	DESCRIPTION
$f_{\max}$	20.0 kHz	Maximal frequency
$c_{\text{air}}$	343 m/s	Speed of sound in air
$c_{\text{poro}}$	272 m/s	Speed of wave to be resolved by the mesh (here the fast pressure wave speed in the PELW domain)

The model includes the driver of the headphone through a lumped equivalent. Thiele–Small parameters obtained from [Ref. 2](#) are used in this model and listed in the table below.

TABLE 2: THIELE SMALL PARAMETERS.

VARIABLE	VALUE	DESCRIPTION
$R_g$	0.8 $\Omega$	Cable resistance
$n_e$	0.7	Voice coil loss factor
$R_E$	124.3 $\Omega$	Voice coil resistance
$L_E$	5.53 mH	Voice coil inductance (constant)
$C_{MS}$	$2.51 \cdot 10^{-3}$ m/N	Suspension compliance
$R_{MS}$	$12.9 \cdot 10^{-3}$ N·s/m	Suspension mechanical losses
$M_{MD}$	314.9 $\mu\text{g}$	Moving mass (voice coil and diaphragm)
$BL$	4.56 T·m	Force factor, flux density (B) times coil length (L)
$V_0$	200 $\sqrt{2}$ mV	Driving voltage (peak)

The model includes a set of perforated plates connecting the different chambers of the headset. The perforated plate parameters used in the model are shown in the table below.

TABLE 3: PERFORATED PLATE PARAMETERS.

VARIABLE	VALUE	DESCRIPTION
$\text{Rad}_{p1}$	10 mm	Radius of the perforated plate I
$n_1$	1	Number of circles defining the plate I
$d_{h1}$	0.5 mm	Diameter of the holes in plate I
$t_{p1}$	0.5 mm	Thickness of perforated plate I
$N_{h1}$	150	Number of holes in the perforated plate I

TABLE 3: PERFORATED PLATE PARAMETERS.

VARIABLE	VALUE	DESCRIPTION
$\text{Rad}_{p2}$	6 mm	Radius of the perforated plate 2
$n_2$	4	Number of circles defining the plate 2
$d_{h2}$	0.5 mm	Diameter of the holes in plate 2
$t_{p2}$	0.5 mm	Thickness of perforated plate 2
$N_{h2}$	200	Number of holes in the perforated plate 2
$\text{Rad}_{p3}$	6 mm	Radius of the perforated plate 3
$n_3$	4	Number of circles defining the plate 3
$d_{h3}$	0.5 mm	Diameter of the holes in plate 3
$t_{p3}$	0.5 mm	Thickness of perforated plate 3
$N_{h3}$	300	Number of holes in the perforated plate 3

Each of the Interior Perforated Plate condition uses an area porosity derived from the parameters listed previously.

The porous material parameters used are those for a generic foam with parameters taken from [Ref. 3](#). The model does not include any compression or prestressing of the foam. Getting a general constitutive model, that predict how all porous properties change with local compression or deformation, is extremely difficult. To include the effects of prestress will typically rely on measuring the porous properties under various compression/deformation states to get local material values. This can, for example, be achieved in impedance tube measurements as shown in [Ref. 4](#), where an optimization is used to fit the material parameters to the test data. In general it should be noticed that good material data is important for the quality of numerical simulations.

### BOUNDARY CONDITIONS

The model makes use of two of the **Physiological** impedance models, described in the *Acoustics Module User's Guide*, to accurately represent the skin (**Human skin**) and the eardrum (**Human ear drum**). The boundaries of the model that included the skin impedance condition are shown in [Figure 2](#).

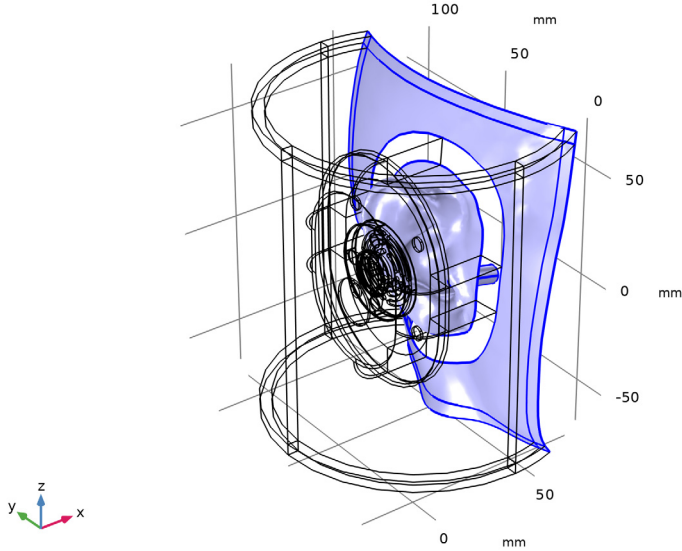
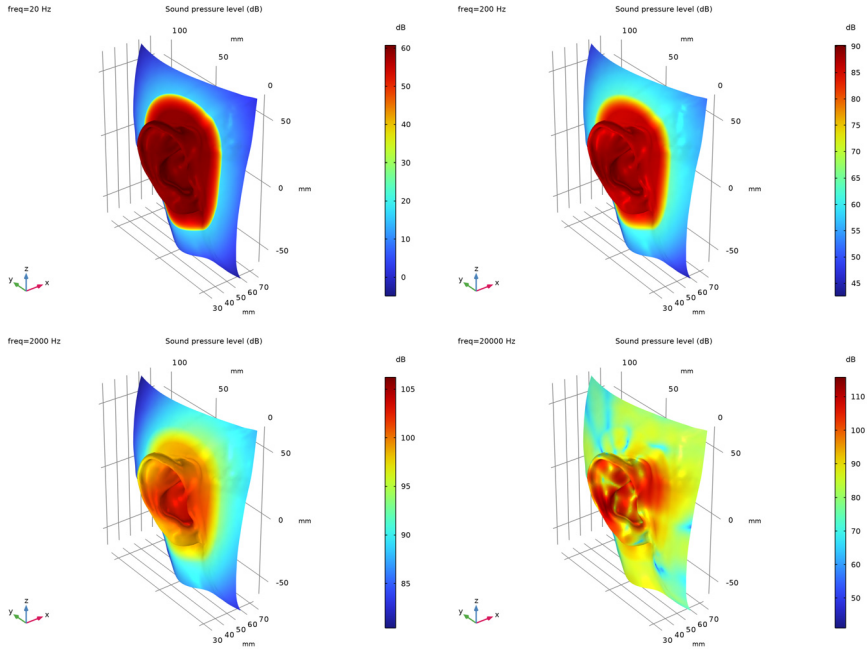

*Figure 2: Boundaries of the acoustic domain with skin impedance.*

Details about the lumped driver approach used in this model are found in the [Lumped Loudspeaker Driver](#) model and in the [Modeling Instructions](#) below. The perforated plates of the headset modeled through the Interior Perforated Plate condition, is described in detail in the *Acoustics Module User's Guide* in the *Theory For The Interior Impedance Models* section.

## Results and Discussion

The sound pressure level on the skin (on and around the ear) at four different frequencies is shown in [Figure 3](#). At the lowest frequencies the effect of the foam is clearly visible, where the large transition in SPL is seen.



*Figure 3: Sound pressure level at the skin at different frequencies.*

The average sound pressure level at the eardrum is shown in [Figure 4](#). This model has been solved on a high performance computer (HPC) with a finer mesh to capture the slow pressure waves and the shear waves. These results are imported and compared to the current model. The results of this finer meshed model show good agreement at low frequency (as all pressure waves are correctly resolved at low frequency in both models) but show significant differences as the frequency increases. The model requires about 28 GB of RAM to solve with the coarse mesh (used in the model) while it requires about 100 GB to solve with the default solver on the HPC system (single node). The model setup and the mesh can easily be modified to resolve all wave speed by modifying the parameter `cporo` from 272[m/s] (fast pressure wave speed) to 96[m/s] (shear wave speed, the slowest wave).

Although it is not shown in this tutorial, it is possible to explore the effect the perforates/ meshes have on the sound pressure level by modifying the Interior Perforated Plate parameters.

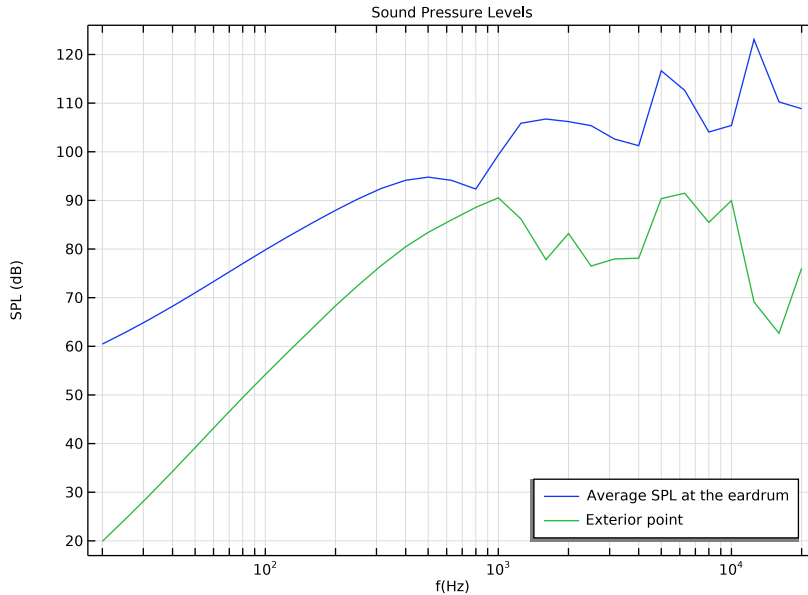

Figure 4: Sound pressure level at the eardrum.

### Notes About the COMSOL Implementation

As described previously, and in the [Modeling Instructions](#) below, only the fast pressure waves have been considered while choosing the mesh size in the PELW domain. This has been done to limit the size of the model and make sure that the model can run on a computer with 32 GB of RAM. The solver setup in the model uses an iterative solver while the fine mesh model has been solved using a direct solver. It is very important to use a tight relative tolerance in the stationary solver (for this model  $2e-7$  is a good choice) when working with iterative solvers. It is good practice to do a convergence analysis on the relative tolerance until the results remain unaltered.

The PML in the model is set up using the **User defined** option for the **Geometry Type**. This is the case as the automatic detection fails when the PML is only part of a cylindrical layer (and is cut using a complex surface). Three PML region have been defined with different expressions for the **Distance function**. One definition for the top, one for the sides, and one for the corners. The distance function is a mathematical expression that describes the

distance from the inner PML boundary to the outer boundary. The distance function variable, `pm11.dDist`, is shown in Figure 5.

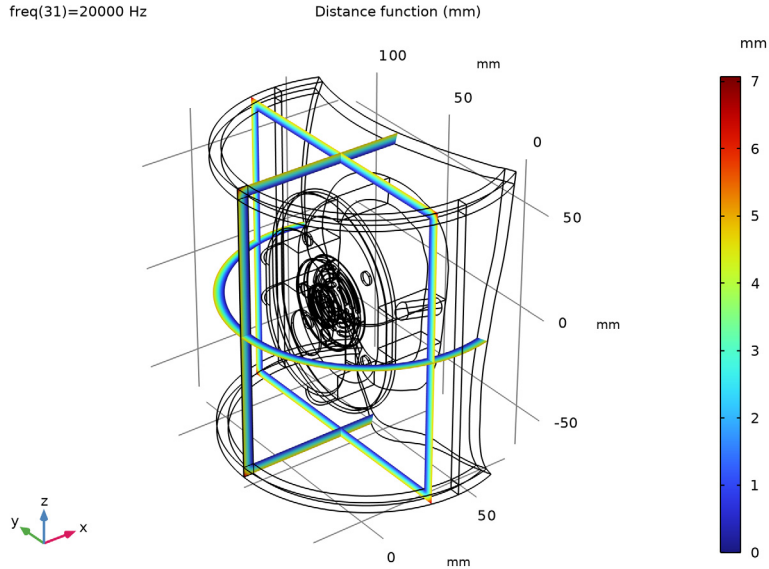

Figure 5: PML distance function.

## References

1. *Lumped Loudspeaker Driver Model Documentation*, from the COMSOL Application Library.
2. C. A. Poldy, “Headphones,” in J. Borwick, *Loudspeaker and Headphone Handbook*, 3rd ed. Focal Press, 2001.
3. J. F. Allard and N. Atalla, *Propagation of Sound in Porous Media, Modeling Sound Absorbing Materials*, 2nd Edition, Wiley, 2009.
4. *Impedance Tube Parameter Estimation with Data Generation*, from the COMSOL Application Library.

---

**Application Library path:** Acoustics\_Module/Electroacoustic\_Transducers/headphone\_artificial\_ear

---

### *Modeling Instructions*



---

From the **File** menu, choose **New**.

#### **NEW**

In the **New** window, click  **Model Wizard**.

#### **MODEL WIZARD**



- 1 In the **Model Wizard** window, click .
- 2 Click  **Done**.

#### **GLOBAL DEFINITIONS**

##### *Model parameters*

- 1 In the **Model Builder** window, under **Global Definitions** click **Parameters I**.
- 2 In the **Settings** window for **Parameters**, type Model parameters in the **Label** text field.
- 3 Locate the **Parameters** section. Click  **Load from File**.
- 4 Browse to the model's Application Libraries folder and double-click the file `headphone_artificial_ear_parameters.txt`.

##### *Perforated plates parameters*

- 1 In the **Home** toolbar, click  **Parameters** and choose **Add > Parameters**.
- 2 In the **Settings** window for **Parameters**, type Perforated plates parameters in the **Label** text field.
- 3 Locate the **Parameters** section. Click  **Load from File**.
- 4 Browse to the model's Application Libraries folder and double-click the file `headphone_artificial_ear_plates.txt`.

##### *Thiele-Small Parameters*





- 1 In the **Home** toolbar, click  **Parameters** and choose **Add > Parameters**.
- 2 In the **Settings** window for **Parameters**, type Thiele-Small Parameters in the **Label** text field.

- 3 Locate the **Parameters** section. Click  **Load from File**.
- 4 Browse to the model's Application Libraries folder and double-click the file `headphone_artificial_ear_ts_parameters.txt`.

## **GEOMETRY I**

- 1 In the **Model Builder** window, under **Component 1 (comp1)** click **Geometry 1**.
- 2 In the **Settings** window for **Geometry**, locate the **Units** section.
- 3 From the **Length unit** list, choose **mm**.  
Import the model geometry from file by following these steps.

### *Import 1 (imp1)*

- 1 In the **Geometry** toolbar, click  **Import**.
- 2 In the **Settings** window for **Import**, locate the **Source** section.
- 3 Click  **Browse**.
- 4 Browse to the model's Application Libraries folder and double-click the file `headphone_artificial_ear_geometry.mphbin`.
- 5 Click  **Import**.
- 6 Click the  **Zoom Extents** button in the **Graphics** toolbar.

- 7 Click the  **Wireframe Rendering** button in the **Graphics** toolbar.  
The figure below shows the model geometry.

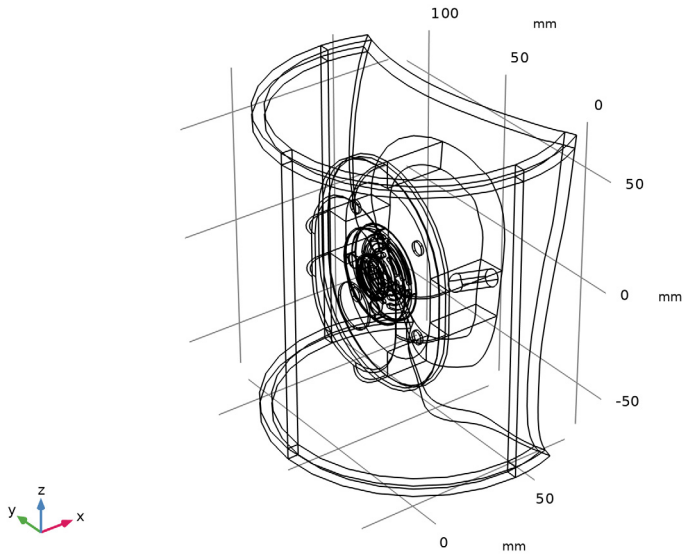

The following steps create the selections that will be used to define the model.

## DEFINITIONS

### *Foam*

- 1 In the **Definitions** toolbar, click  **Explicit**.
- 2 In the **Settings** window for **Explicit**, type Foam in the **Label** text field.

3 Select Domains 15–20 only.

The selection should look like this.

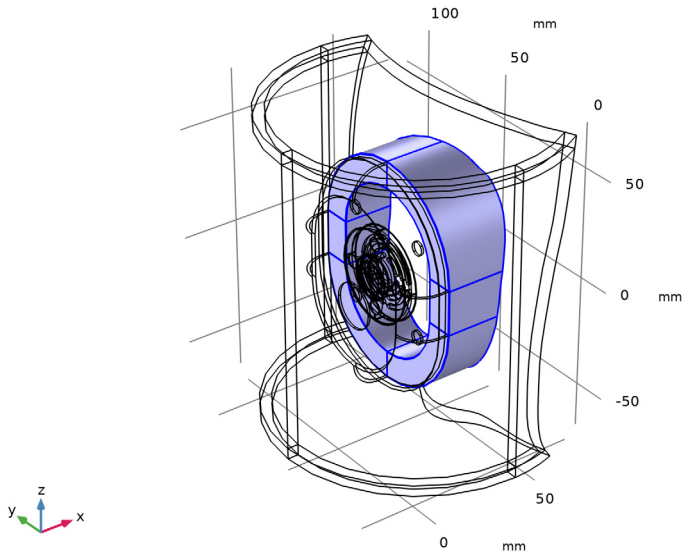

*Moving membrane positive*

- 1 In the **Definitions** toolbar, click  **Explicit**.
- 2 In the **Settings** window for **Explicit**, type *Moving membrane positive* in the **Label** text field.
- 3 Locate the **Input Entities** section. From the **Geometric entity level** list, choose **Boundary**.

4 Select Boundaries 150, 152, 156, and 158 only.

The selection should look like this.

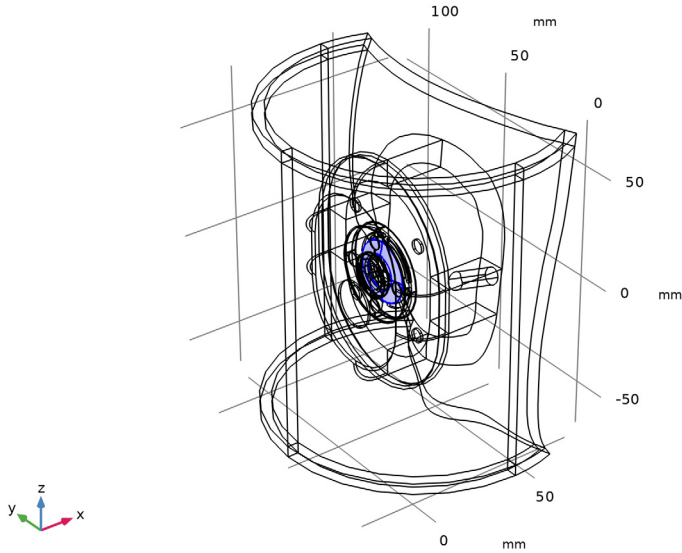

*Moving membrane negative*

- 1 In the **Definitions** toolbar, click  **Explicit**.
- 2 In the **Settings** window for **Explicit**, type *Moving membrane negative* in the **Label** text field.
- 3 Locate the **Input Entities** section. From the **Geometric entity level** list, choose **Boundary**.

4 Select Boundaries 151, 153, 157, and 159 only.

The selection should look like this.

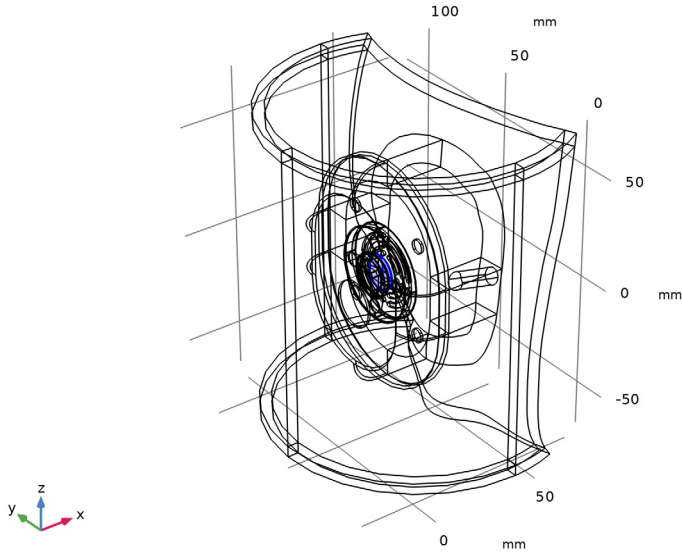

*Interior sound hard boundary*

- 1 In the **Definitions** toolbar, click  **Explicit**.
- 2 In the **Settings** window for **Explicit**, type Interior sound hard boundary in the **Label** text field.
- 3 Locate the **Input Entities** section. From the **Geometric entity level** list, choose **Boundary**.

- 4 Select Boundaries 126–129, 146–149, 154, 155, 160, and 161 only.  
The selection should look like this.

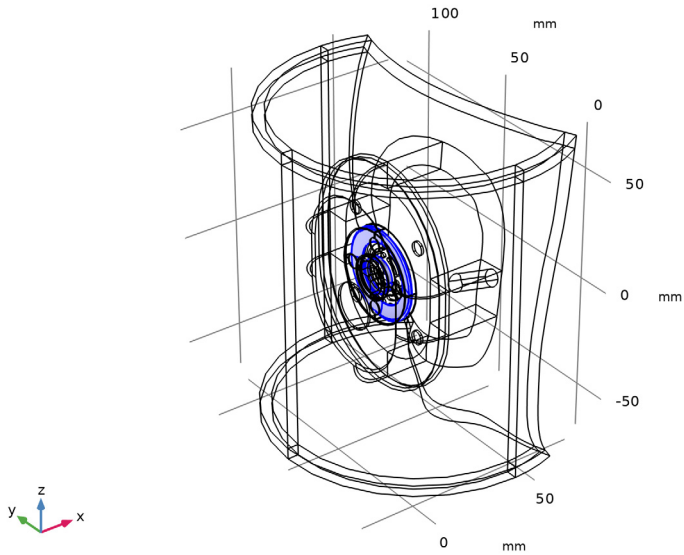

### *Eardrum*

- 1 In the **Definitions** toolbar, click  **Explicit**.
- 2 In the **Settings** window for **Explicit**, type Eardrum in the **Label** text field.
- 3 Locate the **Input Entities** section. From the **Geometric entity level** list, choose **Boundary**.

4 Select Boundary 333 only.

The selection should look like this.

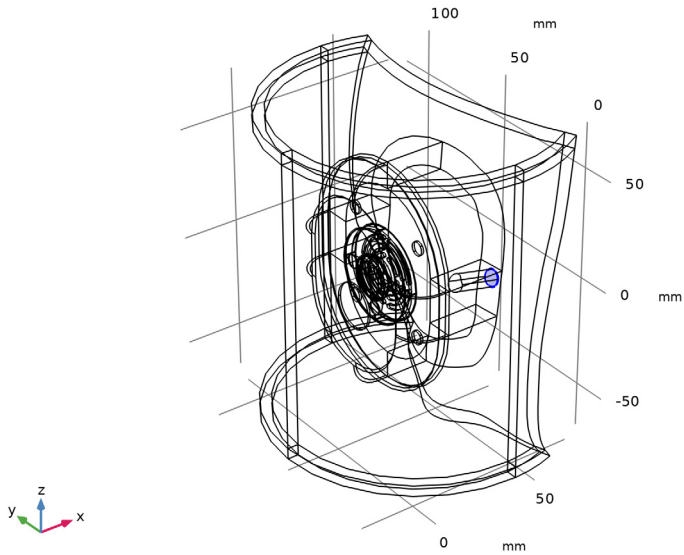

*Skin with PML*

- 1 In the **Definitions** toolbar, click  **Explicit**.
- 2 In the **Settings** window for **Explicit**, locate the **Input Entities** section.
- 3 From the **Geometric entity level** list, choose **Boundary**.
- 4 In the **Label** text field, type Skin with PML.

- 5 Select Boundaries 289, 316–332, 334, and 335 only.  
The selection should look like this.

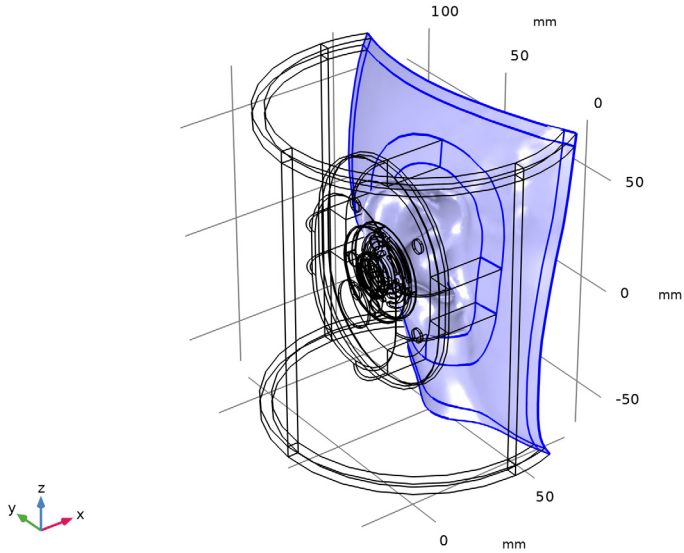

*Skin without PML*

- 1 In the **Definitions** toolbar, click  **Explicit**.
- 2 In the **Settings** window for **Explicit**, type Skin without PML in the **Label** text field.
- 3 Locate the **Input Entities** section. From the **Geometric entity level** list, choose **Boundary**.

- 4 Select Boundaries 289, 317–322, and 324–328 only.  
The selection should look like this.

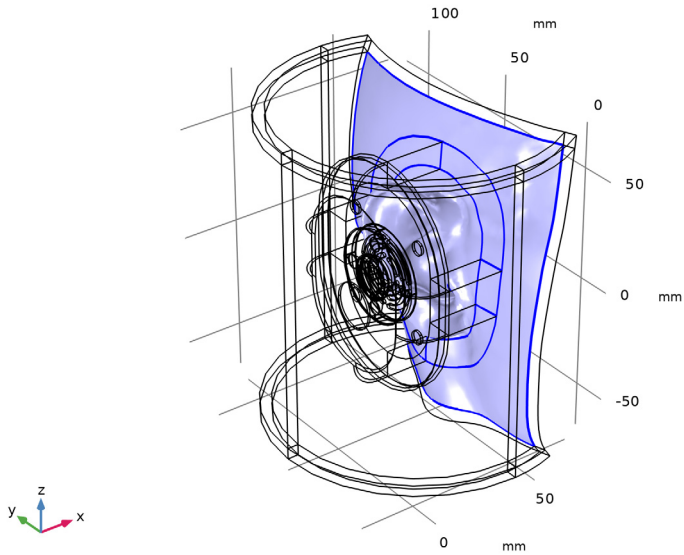

*PML sides*

- 1 In the **Definitions** toolbar, click  **Explicit**.
- 2 In the **Settings** window for **Explicit**, type PML sides in the **Label** text field.

3 Select Domains 3, 4, 22, and 25 only.

The selection should look like this.

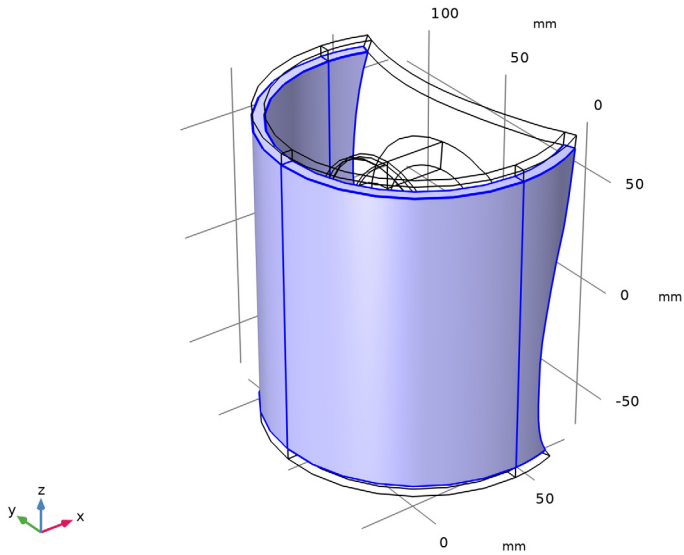

*PML corners*

1 In the **Definitions** toolbar, click  **Explicit**.

2 In the **Settings** window for **Explicit**, type PML corners in the **Label** text field.

3 Select Domains 1, 2, 5, 6, 21, 23, 24, and 26 only.

The selection should look like this.

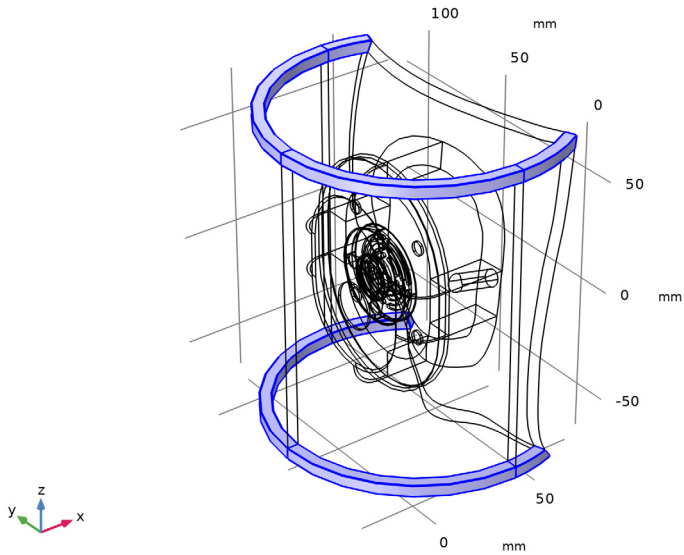

*PML caps*

1 In the **Definitions** toolbar, click  **Explicit**.

2 In the **Settings** window for **Explicit**, type PML caps in the **Label** text field.

3 Select Domains 7 and 9 only.

The selection should look like this.

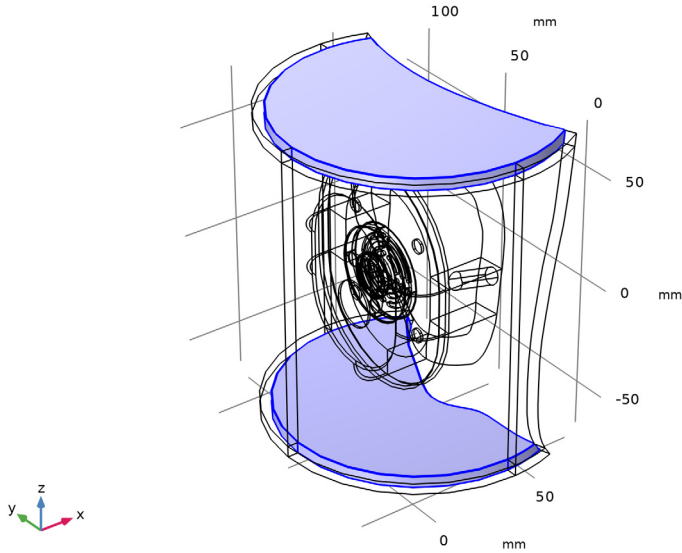

*Perforated plate 1*

- 1 In the **Definitions** toolbar, click  **Explicit**.
- 2 In the **Settings** window for **Explicit**, type Perforated plate 1 in the **Label** text field.
- 3 Locate the **Input Entities** section. From the **Geometric entity level** list, choose **Boundary**.

4 Select Boundary 32 only.

The selection should look like this.

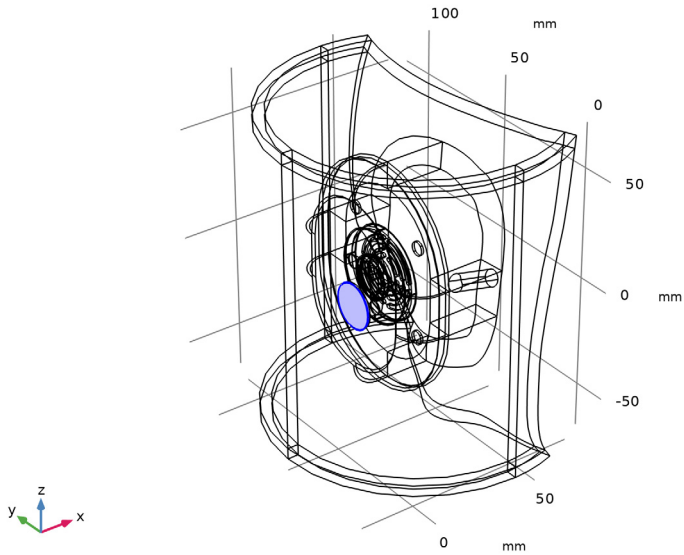

#### *Perforated plate 2*

- 1 In the **Definitions** toolbar, click  **Explicit**.
- 2 In the **Settings** window for **Explicit**, type Perforated plate 2 in the **Label** text field.
- 3 Locate the **Input Entities** section. From the **Geometric entity level** list, choose **Boundary**.

4 Select Boundaries 88, 95, 98, and 113 only.

The selection should look like this.

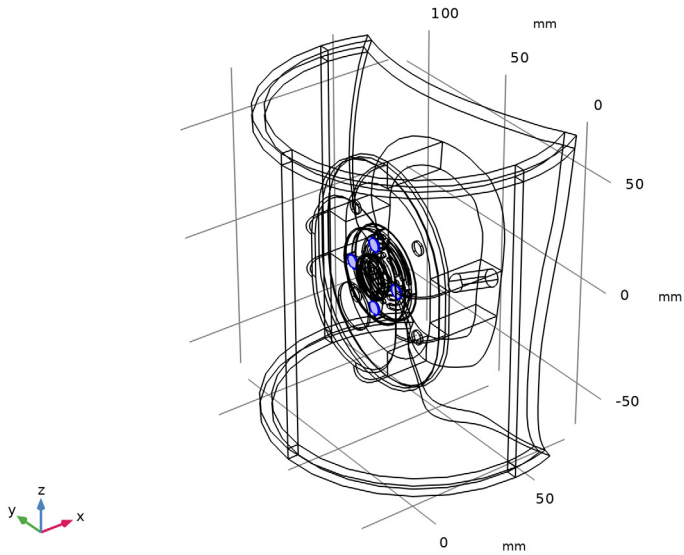

### Perforated plate 3

- 1 In the **Definitions** toolbar, click  **Explicit**.
- 2 In the **Settings** window for **Explicit**, type Perforated plate 3 in the **Label** text field.
- 3 Locate the **Input Entities** section. From the **Geometric entity level** list, choose **Boundary**.

4 Select Boundaries 272, 273, 282, and 283 only.

The selection should look like this.

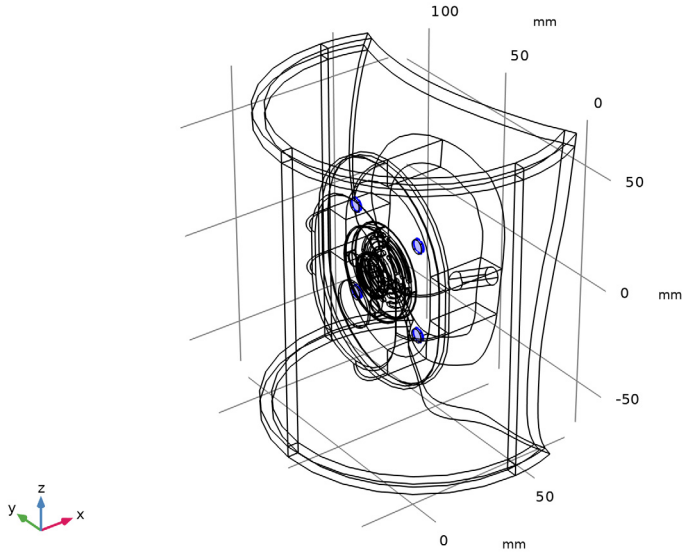

#### *All Domains*

- 1 In the **Definitions** toolbar, click  **Explicit**.
- 2 In the **Settings** window for **Explicit**, type All Domains in the **Label** text field.
- 3 Locate the **Input Entities** section. Select the **All domains** checkbox.

#### *Plastic casing*



- 1 In the **Definitions** toolbar, click  **Explicit**.
- 2 In the **Settings** window for **Explicit**, type Plastic casing in the **Label** text field.

3 Select Domains 10 and 12 only.

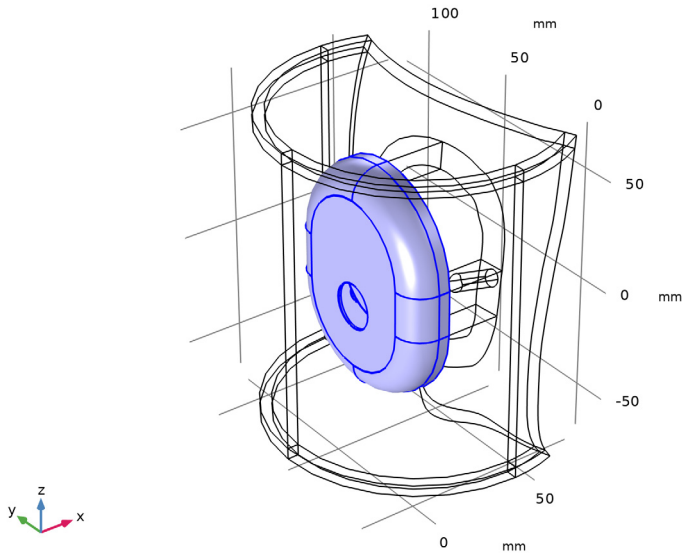

The selection should look like this.



#### *Air with PML*



- 1 In the **Definitions** toolbar, click  **Difference**.
- 2 In the **Settings** window for **Difference**, type Air with PML in the **Label** text field.
- 3 Locate the **Input Entities** section. Under **Selections to add**, click  **Add**.
- 4 In the **Add** dialog, select **All Domains** in the **Selections to add** list.
- 5 Click **OK**.
- 6 In the **Settings** window for **Difference**, locate the **Input Entities** section.
- 7 Under **Selections to subtract**, click  **Add**.
- 8 In the **Add** dialog, in the **Selections to subtract** list, choose **Foam** and **Plastic casing**.
- 9 Click **OK**.

#### *Air without PML*



- 1 In the **Definitions** toolbar, click  **Difference**.
- 2 In the **Settings** window for **Difference**, type Air without PML in the **Label** text field.
- 3 Locate the **Input Entities** section. Under **Selections to add**, click  **Add**.

- 4 In the **Add** dialog, select **Air with PML** in the **Selections to add** list.
- 5 Click **OK**.
- 6 In the **Settings** window for **Difference**, locate the **Input Entities** section.
- 7 Under **Selections to subtract**, click  **Add**.
- 8 In the **Add** dialog, in the **Selections to subtract** list, choose **PML sides**, **PML corners**, and **PML caps**.
- 9 Click **OK**.



#### *Air boundaries*

- 1 In the **Definitions** toolbar, click  **Union**.
- 2 In the **Settings** window for **Union**, type **Air boundaries** in the **Label** text field.
- 3 Locate the **Geometric Entity Level** section. From the **Level** list, choose **Boundary**.
- 4 Locate the **Input Entities** section. Under **Selections to add**, click  **Add**.
- 5 In the **Add** dialog, in the **Selections to add** list, choose **Eardrum**, **Skin with PML**, **Perforated plate 1**, **Perforated plate 2**, and **Perforated plate 3**.
- 6 Click **OK**.

#### *Moving membrane*

- 1 In the **Definitions** toolbar, click  **Union**.
- 2 In the **Settings** window for **Union**, type **Moving membrane** in the **Label** text field.
- 3 Locate the **Geometric Entity Level** section. From the **Level** list, choose **Boundary**.
- 4 Locate the **Input Entities** section. Under **Selections to add**, click  **Add**.
- 5 In the **Add** dialog, in the **Selections to add** list, choose **Moving membrane positive** and **Moving membrane negative**.
- 6 Click **OK**.

#### *Meshed domains without PML and foam*

- 1 In the **Definitions** toolbar, click  **Difference**.
- 2 In the **Settings** window for **Difference**, type **Meshed domains without PML and foam** in the **Label** text field.
- 3 Locate the **Input Entities** section. Under **Selections to add**, click  **Add**.
- 4 In the **Add** dialog, select **All Domains** in the **Selections to add** list.
- 5 Click **OK**.
- 6 In the **Settings** window for **Difference**, locate the **Input Entities** section.
- 7 Under **Selections to subtract**, click  **Add**.

8 In the **Add** dialog, in the **Selections to subtract** list, choose **Foam**, **PML sides**, **PML corners**, **PML caps**, and **Plastic casing**.

9 Click **OK**.

#### *PML*

1 In the **Definitions** toolbar, click  **Union**.

2 In the **Settings** window for **Union**, type PML in the **Label** text field.

3 Locate the **Input Entities** section. Under **Selections to add**, click **+ Add**.

4 In the **Add** dialog, in the **Selections to add** list, choose **PML sides**, **PML corners**, and **PML caps**.

5 Click **OK**.

#### *Model variables*

1 In the **Model Builder** window, right-click **Definitions** and choose **Variables**.

2 In the **Settings** window for **Variables**, type Model variables in the **Label** text field.

3 Locate the **Variables** section. Click  **Load from File**.

4 Browse to the model's Application Libraries folder and double-click the file `headphone_artificial_ear_variables.txt`.

### **ADD PHYSICS**

1 In the **Home** toolbar, click  **Add Physics** to open the **Add Physics** window.

2 Go to the **Add Physics** window.

3 In the tree, select **AC/DC** > **Electrical Circuit (cir)**.

4 Click the **Add to Selection** button in the window toolbar.

5 In the **Home** toolbar, click  **Add Physics** to close the **Add Physics** window.

### **ELECTRICAL CIRCUIT (CIR)**

#### *Voltage Source 1 (V1)*

1 In the **Electrical Circuit** toolbar, click  **Voltage Source**.

2 In the **Settings** window for **Voltage Source**, locate the **Node Connections** section.

3 In the table, enter the following settings:

Label	Node names
n	0

4 Locate the **Device Parameters** section. In the  $v_{src}$  text field, type V0.

### Resistor 1 (R1)

- 1 In the **Electrical Circuit** toolbar, click  **Resistor**.
- 2 In the **Settings** window for **Resistor**, locate the **Node Connections** section.
- 3 In the table, enter the following settings:

Label	Node names
p	1
n	2

- 4 Locate the **Device Parameters** section. In the  $R$  text field, type  $R_g$ .

### Resistor 2 (R2)

- 1 In the **Electrical Circuit** toolbar, click  **Resistor**.
- 2 In the **Settings** window for **Resistor**, locate the **Node Connections** section.
- 3 In the table, enter the following settings:

Label	Node names
p	2
n	3

- 4 Locate the **Device Parameters** section. In the  $R$  text field, type  $R_E$ .

### Inductor 1 (L1)

- 1 In the **Electrical Circuit** toolbar, click  **Inductor**.
- 2 In the **Settings** window for **Inductor**, locate the **Node Connections** section.
- 3 In the table, enter the following settings:

Label	Node names
p	3
n	4

- 4 Locate the **Device Parameters** section. In the  $L$  text field, type  $L_E$ .

### Resistor 3 (R3)

- 1 In the **Electrical Circuit** toolbar, click  **Resistor**.
- 2 In the **Settings** window for **Resistor**, locate the **Node Connections** section.

3 In the table, enter the following settings:

Label	Node names
p	3
n	4

4 Locate the **Device Parameters** section. In the  $R$  text field, type Rp\_E.

*Inductor 2 (L2)*

1 In the **Electrical Circuit** toolbar, click  **Inductor**.

2 In the **Settings** window for **Inductor**, locate the **Node Connections** section.

3 In the table, enter the following settings:

Label	Node names
p	6
n	7

4 Locate the **Device Parameters** section. In the  $L$  text field, type M\_MD[H/kg].

*Current-Controlled Voltage Source 1 (H1)*

1 In the **Electrical Circuit** toolbar, click  **Current-Controlled Voltage Source**.

2 In the **Settings** window for **Current-Controlled Voltage Source**, locate the **Node Connections** section.

3 In the table, enter the following settings:

Label	Node names
p	4
n	0

4 Locate the **Current Measurement** section. From the **Measure current for device** list, choose **Inductor 2 (L2)**.

5 In the **Gain** text field, type BL [m/Wb\*ohm].

*Current-Controlled Voltage Source 2 (H2)*

1 In the **Electrical Circuit** toolbar, click  **Current-Controlled Voltage Source**.

2 In the **Settings** window for **Current-Controlled Voltage Source**, locate the **Node Connections** section.

3 In the table, enter the following settings:

Label	Node names
p	6
n	0

4 Locate the **Current Measurement** section. In the **Gain** text field, type  $BL[m/Wb \cdot ohm]$ .

5 From the **Measure current for device** list, choose **Resistor 2 (R2)**.

*Resistor 4 (R4)*

1 In the **Electrical Circuit** toolbar, click  **Resistor**.

2 In the **Settings** window for **Resistor**, locate the **Node Connections** section.

3 In the table, enter the following settings:

Label	Node names
p	7

4 Locate the **Device Parameters** section. In the  $R$  text field, type  $R\_MS[ohm/kg \cdot s]$ .

*Capacitor 1 (C1)*

1 In the **Electrical Circuit** toolbar, click  **Capacitor**.

2 In the **Settings** window for **Capacitor**, locate the **Node Connections** section.

3 In the table, enter the following settings:

Label	Node names
p	8

4 Locate the **Device Parameters** section. In the  $C$  text field, type  $C\_MS[F \cdot N/m]$ .

*External I vs. U I (IvsUI)*

1 In the **Electrical Circuit** toolbar, click  **External I vs. U**.



2 In the **Settings** window for **External I vs. U**, locate the **Node Connections** section.

3 In the table, enter the following settings:

Label	Node names
p	9
n	0

The **Electric potential** selection is done once the **Interior Lumped Speaker Boundary** has been added in pressure acoustics. The coupling between the circuit and the acoustics domain will then be automatic.

#### ADD PHYSICS

- 1 In the **Home** toolbar, click  **Add Physics** to open the **Add Physics** window.
- 2 Go to the **Add Physics** window.
- 3 In the tree, select **Acoustics** > **Pressure Acoustics** > **Pressure Acoustics, Frequency Domain (acpr)**.
- 4 Click the **Add to Selection** button in the window toolbar.
- 5 In the **Home** toolbar, click  **Add Physics** to close the **Add Physics** window.

#### PRESSURE ACOUSTICS, FREQUENCY DOMAIN (ACPR)

- 1 In the **Settings** window for **Pressure Acoustics, Frequency Domain**, locate the **Domain Selection** section.
- 2 From the **Selection** list, choose **Air with PML**.

#### *Eardrum Impedance*

- 1 In the **Physics** toolbar, click  **Boundaries** and choose **Impedance**.
- 2 In the **Settings** window for **Impedance**, type **Eardrum Impedance** in the **Label** text field.
- 3 Locate the **Boundary Selection** section. From the **Selection** list, choose **Eardrum**.
- 4 Locate the **Impedance** section. From the **Impedance model** list, choose **Physiological**.
- 5 From the list, choose **Human ear drum**.

#### *Skin impedance*

- 1 In the **Physics** toolbar, click  **Boundaries** and choose **Impedance**.
- 2 In the **Settings** window for **Impedance**, type **Skin impedance** in the **Label** text field.
- 3 Locate the **Boundary Selection** section. From the **Selection** list, choose **Skin with PML**.
- 4 Locate the **Impedance** section. From the **Impedance model** list, choose **Physiological**.

The selection should look like [Figure 2](#).

#### *Interior Sound Hard Boundary (Wall) 1*

- 1 In the **Physics** toolbar, click  **Boundaries** and choose **Interior Sound Hard Boundary (Wall)**.
- 2 In the **Settings** window for **Interior Sound Hard Boundary (Wall)**, locate the **Boundary Selection** section.
- 3 From the **Selection** list, choose **Interior sound hard boundary**.

#### *Interior Perforated Plate 1*

- 1 In the **Physics** toolbar, click  **Boundaries** and choose **Interior Perforated Plate**.
- 2 In the **Settings** window for **Interior Perforated Plate**, locate the **Boundary Selection** section.
- 3 From the **Selection** list, choose **Perforated plate 1**.
- 4 Locate the **Interior Perforated Plate** section. In the  $d_h$  text field, type dh1.
- 5 In the  $t_p$  text field, type tp1.
- 6 In the  $\sigma$  text field, type sigma1.

#### *Interior Perforated Plate 2*

- 1 In the **Physics** toolbar, click  **Boundaries** and choose **Interior Perforated Plate**.
- 2 In the **Settings** window for **Interior Perforated Plate**, locate the **Boundary Selection** section.
- 3 From the **Selection** list, choose **Perforated plate 2**.
- 4 Locate the **Interior Perforated Plate** section. In the  $d_h$  text field, type dh2.
- 5 In the  $t_p$  text field, type tp2.
- 6 In the  $\sigma$  text field, type sigma2.

#### *Interior Perforated Plate 3*

- 1 In the **Physics** toolbar, click  **Boundaries** and choose **Interior Perforated Plate**.
- 2 In the **Settings** window for **Interior Perforated Plate**, locate the **Boundary Selection** section.
- 3 From the **Selection** list, choose **Perforated plate 3**.
- 4 Locate the **Interior Perforated Plate** section. In the  $d_h$  text field, type dh3.
- 5 In the  $t_p$  text field, type tp3.
- 6 In the  $\sigma$  text field, type sigma3.

### *Interior Lumped Speaker Boundary 1*



- 1 In the **Physics** toolbar, click  **Boundaries** and choose **Interior Lumped Speaker Boundary**.
- 2 In the **Settings** window for **Interior Lumped Speaker Boundary**, locate the **Boundary Selection** section.
- 3 From the **Selection** list, choose **Moving membrane**.
- 4 Locate the **Speaker Geometry** section. From the  $e_{ax}$  list, choose **User defined**.

## **ELECTRICAL CIRCUIT (CIR)**

### *External I vs. U 1 (lvsUI)*

- 1 In the **Model Builder** window, under **Component 1 (comp1) > Electrical Circuit (cir)** click **External I vs. U 1 (lvsUI)**.
- 2 In the **Settings** window for **External I vs. U**, locate the **External Device** section.
- 3 From the  $V$  list, choose **Voltage from lumped speaker boundary (acpr/ilsb1)**.

## **ADD PHYSICS**

- 1 In the **Home** toolbar, click  **Add Physics** to open the **Add Physics** window.
- 2 Go to the **Add Physics** window.
- 3 In the tree, select **Acoustics > Elastic Waves > Poroelastic Waves (pelw)**.
- 4 Click the **Add to Selection** button in the window toolbar.
- 5 In the **Home** toolbar, click  **Add Physics** to close the **Add Physics** window.

## **POROELASTIC WAVES (PELW)**

- 1 In the **Settings** window for **Poroelastic Waves**, locate the **Domain Selection** section.
- 2 From the **Selection** list, choose **Foam**.

### *Fixed Constraint 1*

- 1 In the **Physics** toolbar, click  **Boundaries** and choose **Fixed Constraint**.
- 2 Select Boundaries 260, 262, 265, 274, 278, 284, 318–322, and 326 only.

## **MULTIPHYSICS**

### *Acoustic–Porous Boundary 1 (apb1)*

- 1 In the **Physics** toolbar, click  **Multiphysics Couplings** and choose **Boundary > Acoustic–Porous Boundary**.

2 In the **Settings** window for **Acoustic–Porous Boundary**, locate the **Boundary Selection** section.

3 From the **Selection** list, choose **All boundaries**.

The following steps define the PML used in the model. The number of stretching directions and the distance function are defined manually to make sure that the PML works as intended.

## DEFINITIONS

*Perfectly Matched Layer 1 (pml1)*

1 In the **Definitions** toolbar, click  **Perfectly Matched Layer**.

2 In the **Settings** window for **Perfectly Matched Layer**, locate the **Domain Selection** section.

3 From the **Selection** list, choose **PML sides**.

4 Locate the **Geometry** section. From the **Type** list, choose **User defined**.

5 In the table, enter the following settings:

	Distance function (m)	Thickness (m)
Direction 1	$\sqrt{(x-40[\text{mm}])^2+(y-50[\text{mm}])^2}-60[\text{mm}]$	5 [mm]

6 Locate the **Scaling** section. In the **PML scaling curvature parameter** text field, type 3.

*Perfectly Matched Layer 2 (pml2)*

1 In the **Definitions** toolbar, click  **Perfectly Matched Layer**.

2 In the **Settings** window for **Perfectly Matched Layer**, locate the **Domain Selection** section.

3 From the **Selection** list, choose **PML caps**.

4 Locate the **Geometry** section. From the **Type** list, choose **User defined**.

5 In the table, enter the following settings:

	Distance function (m)	Thickness (m)
Direction 1	$\text{abs}(z)-65[\text{mm}]$	5 [mm]

6 Locate the **Scaling** section. In the **PML scaling curvature parameter** text field, type 3.

*Perfectly Matched Layer 3 (pml3)*

1 In the **Definitions** toolbar, click  **Perfectly Matched Layer**.

2 In the **Settings** window for **Perfectly Matched Layer**, locate the **Domain Selection** section.

3 From the **Selection** list, choose **PML corners**.

- 4 Locate the **Geometry** section. From the **Type** list, choose **User defined**.
- 5 From the **Number of stretching directions** list, choose **2**.
- 6 In the table, enter the following settings:

	<b>Distance function (m)</b>	<b>Thickness (m)</b>
Direction 1	$\sqrt{(x-40[\text{mm}])^2+(y-50[\text{mm}])^2}-60[\text{mm}]$	5 [mm]
Direction 2	$\text{abs}(z)-65[\text{mm}]$	5 [mm]

- 7 Locate the **Scaling** section. In the **PML scaling curvature parameter** text field, type 3.

#### **ADD MATERIAL**

- 1 In the **Materials** toolbar, click  **Add Material** to open the **Add Material** window.
- 2 Go to the **Add Material** window.
- 3 In the tree, select **Built-in > Air**.
- 4 Click the **Add to Component** button in the window toolbar.

#### **MATERIALS**

##### *Air - Domains*

- 1 In the **Settings** window for **Material**, type **Air - Domains** in the **Label** text field.
- 2 Locate the **Geometric Entity Selection** section. From the **Selection** list, choose **Air with PML**.

#### **POROELASTIC WAVES (PELW)**

##### *Poroelastic Material 1*

- 1 In the **Model Builder** window, under **Component 1 (comp1) > Poroelastic Waves (pelw)** click **Poroelastic Material 1**.
- 2 In the **Settings** window for **Poroelastic Material**, locate the **Fluid Properties** section.
- 3 From the **Fluid material** list, choose **Air - Domains (mat1)**.

#### **ADD MATERIAL**

- 1 Go to the **Add Material** window.
- 2 In the tree, select **Built-in > Air**.
- 3 Click the **Add to Component** button in the window toolbar.
- 4 In the **Materials** toolbar, click  **Add Material** to close the **Add Material** window.

## MATERIALS

### *Air - Boundaries*

- 1 In the **Settings** window for **Material**, type Air - Boundaries in the **Label** text field.
- 2 Locate the **Geometric Entity Selection** section. From the **Geometric entity level** list, choose **Boundary**.
- 3 From the **Selection** list, choose **Air boundaries**.

### *Foam*

- 1 In the **Model Builder** window, right-click **Materials** and choose **Blank Material**.
- 2 In the **Settings** window for **Material**, type Foam in the **Label** text field.
- 3 Locate the **Geometric Entity Selection** section. From the **Selection** list, choose **Foam**.
- 4 Locate the **Material Contents** section. In the table, enter the following settings:

Property	Variable	Value	Unit	Property group
Tortuosity factor	tau_iso ; tau <sub>ii</sub> = tau_iso, tau <sub>ij</sub> = 0	1.18		Poroacoustics model
Flow resistivity	Rf_iso ; Rf <sub>ii</sub> = Rf_iso, Rf <sub>ij</sub> = 0	34000 [N* s/m <sup>4</sup> ]	Pa·s/m <sup>2</sup>	Poroacoustics model
Viscous characteristic length	Lv_iso ; Lv <sub>ii</sub> = Lv_iso, Lv <sub>ij</sub> = 0	60 [um]	m	Poroacoustics model
Poisson's ratio	nu	0.3		Young's modulus and Poisson's ratio
Shear modulus	G	500 [kPa]	N/m <sup>2</sup>	Bulk modulus and shear modulus
Density	rho	30 [kg/ m <sup>3</sup> ]	kg/m <sup>3</sup>	Basic
Porosity	epsilon	0.85		Basic
Thermal characteristic length	Lth	87 [um]	m	Poroacoustics model
Isotropic structural loss factor	eta_s	0.015		Basic

In this model the mesh is set up manually. Proceed by directly adding the desired mesh component. Make sure that the model is correctly resolved in the frequency range.

## MESH I

### *Free Tetrahedral I*

In the **Mesh** toolbar, click  **Free Tetrahedral**.

### *Size*

- 1 In the **Model Builder** window, click **Size**.
- 2 In the **Settings** window for **Size**, locate the **Element Size** section.
- 3 Click the **Custom** button.
- 4 Locate the **Element Size Parameters** section. In the **Maximum element size** text field, type  $\lambda_{air}/5$ .
- 5 In the **Minimum element size** text field, type 1 [mm].
- 6 In the **Maximum element growth rate** text field, type 1.4.
- 7 In the **Curvature factor** text field, type 0.5.
- 8 In the **Resolution of narrow regions** text field, type 1.
- 9 Click  **Build Selected**.

### *Mapped I*

- 1 In the **Mesh** toolbar, click  **More Generators** and choose **Mapped**.
- 2 Select Boundaries 261, 264, 267, 276, 281, and 288 only.

### *Size I*

- 1 Right-click **Mapped I** and choose **Size**.
- 2 In the **Settings** window for **Size**, locate the **Element Size** section.
- 3 Click the **Custom** button.
- 4 Locate the **Element Size Parameters** section.
- 5 Select the **Maximum element size** checkbox. In the associated text field, type  $\lambda_{poro}/7.5$ .

All the waves propagating in the poroelastic waves (PELW) domain should be considered for the determination of the mesh size. The parameter `cporo` uses the slowest wave speed in the PELW, in this case the shear waves. Use 7.5 elements per wavelength to make sure that the shear waves are correctly resolved.

### *Swept I*

- 1 In the **Mesh** toolbar, click  **Swept**.
- 2 In the **Settings** window for **Swept**, locate the **Domain Selection** section.
- 3 From the **Geometric entity level** list, choose **Domain**.

- 4 From the **Selection** list, choose **Foam**.

#### *Size 1*

- 1 Right-click **Swept 1** and choose **Size**.
- 2 In the **Settings** window for **Size**, locate the **Element Size** section.
- 3 Click the **Custom** button.
- 4 Locate the **Element Size Parameters** section.
- 5 Select the **Maximum element size** checkbox. In the associated text field, type  $\lambda_{\text{poro}}/7.5$ .

#### *Free Tetrahedral 1*

- 1 In the **Model Builder** window, under **Component 1 (comp1) > Mesh 1** click **Free Tetrahedral 1**.
- 2 In the **Settings** window for **Free Tetrahedral**, locate the **Domain Selection** section.
- 3 From the **Geometric entity level** list, choose **Domain**.
- 4 From the **Selection** list, choose **Meshed domains without PML and foam**.

#### *Size 1*

- 1 Right-click **Free Tetrahedral 1** and choose **Size**.
- 2 In the **Settings** window for **Size**, locate the **Geometric Entity Selection** section.
- 3 From the **Geometric entity level** list, choose **Boundary**.
- 4 From the **Selection** list, choose **Interior sound hard boundary**.
- 5 Locate the **Element Size** section. Click the **Custom** button.
- 6 Locate the **Element Size Parameters** section.
- 7 Select the **Maximum element size** checkbox. In the associated text field, type  $2.0[\text{mm}]$ .
- 8 Click  **Build All**.

#### *Swept 2*



- 1 In the **Mesh** toolbar, click  **Swept**.
- 2 In the **Settings** window for **Swept**, locate the **Domain Selection** section.
- 3 From the **Geometric entity level** list, choose **Domain**.
- 4 From the **Selection** list, choose **PML**.

#### *Distribution 1*

- 1 Right-click **Swept 2** and choose **Distribution**.
- 2 In the **Settings** window for **Distribution**, locate the **Distribution** section.

- 3 In the **Number of elements** text field, type 10.
- 4 Click  **Build All**.

### ADD STUDY

- 1 In the **Home** toolbar, click  **Add Study** to open the **Add Study** window.
- 2 Go to the **Add Study** window.
- 3 Find the **Studies** subsection. In the **Select Study** tree, select **General Studies > Frequency Domain**.
- 4 Click the **Add Study** button in the window toolbar.
- 5 In the **Home** toolbar, click  **Add Study** to close the **Add Study** window.

### STUDY I

#### *Step 1: Frequency Domain*



- 1 In the **Settings** window for **Frequency Domain**, locate the **Study Settings** section.
- 2 Click  **Range**.
- 3 In the **Range** dialog, choose **ISO preferred frequencies** from the **Entry method** list.
- 4 In the **Start frequency** text field, type 20.
- 5 In the **Stop frequency** text field, type 20000.
- 6 From the **Interval** list, choose **I/3 octave**.
- 7 Click **Replace**.

#### *Solution I (sol1)*

- 1 In the **Study** toolbar, click  **Show Default Solver**.
- 2 In the **Model Builder** window, expand the **Solution I (sol1)** node.  
Enable the suggested iterative solver and compute.
- 3 In the **Model Builder** window, expand the **Study I > Solver Configurations > Solution I (sol1) > Stationary Solver I** node.
- 4 Right-click **Study I > Solver Configurations > Solution I (sol1) > Stationary Solver I > Suggested Iterative Solver (GMRES with GMG and Direct Precond.) (apb1)** and choose **Enable**.

Move the degrees of freedom related to the current to the Direct Preconditioner. For this model it helps the model to converge faster for low frequencies.

- 5 In the **Model Builder** window, expand the **Study I > Solver Configurations > Solution I (sol1) > Stationary Solver I >**



- Suggested Iterative Solver (GMRES with GMG and Direct Precond.) (apb1)** node, then click **Multigrid I**.
- 6 In the **Settings** window for **Multigrid**, click to expand the **Hybridization** section.
  - 7 In the **Preconditioner variables** list, choose **Currents (comp1.currents)** and **Currents, Time Derivatives (comp1.current\_time)**.
  - 8 Under **Preconditioner variables**, click  **Delete**.
  - 9 In the **Model Builder** window, under **Study I > Solver Configurations > Solution I (sol1) > Stationary Solver I > Suggested Iterative Solver (GMRES with GMG and Direct Precond.) (apb1)** click **Direct Preconditioner I**.
  - 10 In the **Settings** window for **Direct Preconditioner**, click to expand the **Hybridization** section.
  - 11 Under **Preconditioner variables**, click  **Add**.
  - 12 In the **Add** dialog, in the **Preconditioner variables** list, choose **Currents (comp1.currents)** and **Currents, Time Derivatives (comp1.current\_time)**.
  - 13 Click **OK**.
  - 14 In the **Study** toolbar, click  **Compute**.

## RESULTS

### *Acoustic Pressure (acpr)*

Click the  **Go to Default View** button in the **Graphics** toolbar.

### *Cut Point 3D I*

- 1 In the **Results** toolbar, click  **Cut Point 3D**.
- 2 In the **Settings** window for **Cut Point 3D**, locate the **Point Data** section.
- 3 In the **x** text field, type -10[mm].
- 4 In the **y** text field, type 50[mm].
- 5 In the **z** text field, type 0.
- 6 Click  **Plot**.

### *Surface I*



- 1 In the **Model Builder** window, expand the **Acoustic Pressure (acpr)** node.
- 2 Right-click **Surface I** and choose **Delete**.

### *Acoustic Pressure (acpr)*

- 1 In the **Settings** window for **3D Plot Group**, click to expand the **Selection** section.

- 2 From the **Geometric entity level** list, choose **Domain**.
- 3 Select Domains 8, 11, and 13–20 only.
- 4 Select the **Apply to dataset edges** checkbox.

#### *Multislice 1*

- 1 In the **Acoustic Pressure (acpr)** toolbar, click  **More Plots** and choose **Multislice**.
- 2 In the **Settings** window for **Multislice**, locate the **Expression** section.
- 3 In the **Expression** text field, type `if(isnan(acpr.p_t),pe1w.p_t,acpr.p_t)`.
- 4 Select the **Description** checkbox. In the associated text field, type `Total acoustic pressure`.
- 5 Locate the **Coloring and Style** section. From the **Color table** list, choose **Wave**.
- 6 From the **Scale** list, choose **Linear symmetric**.
- 7 In the **Acoustic Pressure (acpr)** toolbar, click  **Plot**.

The plot should look like this.

#### *Surface 1*

- 1 In the **Model Builder** window, expand the **Sound Pressure Level (acpr)** node.
- 2 Right-click **Surface 1** and choose **Delete**.

#### *Sound Pressure Level (acpr)*

- 1 In the **Settings** window for **3D Plot Group**, locate the **Selection** section.
- 2 From the **Geometric entity level** list, choose **Domain**.
- 3 Select Domains 8, 11, and 13–20 only.
- 4 Select the **Apply to dataset edges** checkbox.



#### *Multislice 1*

- 1 In the **Sound Pressure Level (acpr)** toolbar, click  **More Plots** and choose **Multislice**.
- 2 In the **Settings** window for **Multislice**, locate the **Expression** section.
- 3 In the **Expression** text field, type `if(isnan(acpr.Lp),pe1w.Lp_t,acpr.Lp)`.
- 4 Select the **Description** checkbox. In the associated text field, type `Total sound pressure level`.
- 5 Click to expand the **Coloring and Style** section. From the **Color table** list, choose **Rainbow**.
- 6 From the **Scale** list, choose **Linear**.
- 7 Click to expand the **Quality** section. From the **Evaluation settings** list, choose **Manual**.
- 8 From the **Resolution** list, choose **Finer**.

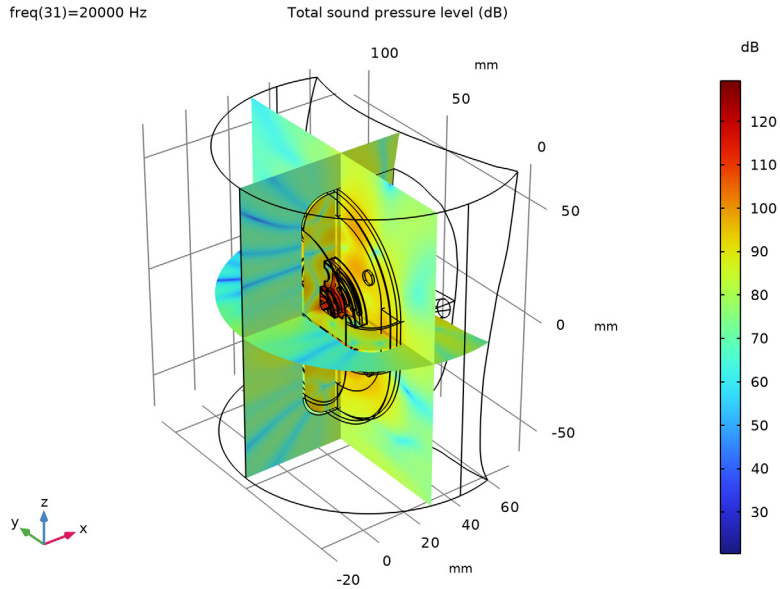
- 9 In the **Sound Pressure Level (acpr)** toolbar, click  **Plot**.



## RESULT TEMPLATES

- 1 In the **Results** toolbar, click  **Result Templates** to open the **Result Templates** window.
- 2 Go to the **Result Templates** window.
- 3 In the tree, select **Study 1/Solution 1 (sol1) > Pressure Acoustics, Frequency Domain > Sound Pressure Level (acpr)**.
- 4 Click the **Add Result Template** button in the window toolbar.
- 5 In the **Results** toolbar, click  **Result Templates** to close the **Result Templates** window.

## RESULTS

### *Sound Pressure Level on Manikin Surface*

- 1 In the **Settings** window for **3D Plot Group**, type **Sound Pressure Level on Manikin Surface** in the **Label** text field.
- 2 Click to expand the **Title** section. From the **Title type** list, choose **Manual**.
- 3 In the **Title** text area, type **Sound pressure level (dB)**.
- 4 In the **Parameter indicator** text field, type **freq=eval(freq) Hz**.
- 5 Locate the **Plot Settings** section. Clear the **Plot dataset edges** checkbox.

### *Selection 1*

- 1 In the **Model Builder** window, expand the **Sound Pressure Level on Manikin Surface** node.
- 2 Right-click **Surface 1** and choose **Selection**.
- 3 In the **Settings** window for **Selection**, locate the **Selection** section.
- 4 From the **Selection** list, choose **Skin without PML**.

### *Surface 2*



- 1 Right-click **Surface 1** and choose **Duplicate**.
- 2 In the **Settings** window for **Surface**, locate the **Expression** section.
- 3 In the **Expression** text field, type `p01w.Lp`.
- 4 Click to expand the **Inherit Style** section. From the **Plot** list, choose **Surface 1**.
- 5 In the **Sound Pressure Level on Manikin Surface** toolbar, click  **Plot**.

The image should look like [Figure 3](#).

### *Sound Pressure Levels*



- 1 In the **Results** toolbar, click  **ID Plot Group**.
- 2 In the **Settings** window for **ID Plot Group**, type **Sound Pressure Levels** in the **Label** text field.
- 3 Click to expand the **Title** section. From the **Title type** list, choose **Label**.
- 4 Locate the **Plot Settings** section.
- 5 Select the **x-axis label** checkbox. In the associated text field, type `f (Hz)`.
- 6 Select the **y-axis label** checkbox. In the associated text field, type `SPL (dB)`.
- 7 Locate the **Legend** section. From the **Position** list, choose **Lower right**.

### *Average SPL at the eardrum*

- 1 In the **Sound Pressure Levels** toolbar, click  **More Plots** and choose **Octave Band**.
- 2 In the **Settings** window for **Octave Band**, type **Average SPL at the eardrum** in the **Label** text field.
- 3 Locate the **Selection** section. From the **Geometric entity level** list, choose **Boundary**.
- 4 From the **Selection** list, choose **Eardrum**.
- 5 Locate the **Plot** section. From the **Quantity** list, choose **Continuous power spectral density**.
- 6 In the **Sound Pressure Levels** toolbar, click  **Plot**.
- 7 Click to expand the **Legends** section. Select the **Show legends** checkbox.
- 8 Find the **Include** subsection. Select the **Label** checkbox.

- 9 Clear the **Solution** checkbox.
- 10 Clear the **Description** checkbox.

#### *Exterior point*



- 1 In the **Model Builder** window, right-click **Sound Pressure Levels** and choose **Point Graph**.
- 2 In the **Settings** window for **Point Graph**, type Exterior point in the **Label** text field.
- 3 Locate the **Data** section. From the **Dataset** list, choose **Cut Point 3D I**.
- 4 Locate the **y-Axis Data** section. In the **Expression** text field, type `acpr.Lp`.
- 5 In the **Sound Pressure Levels** toolbar, click  **Plot**.
- 6 Click to expand the **Legends** section. Select the **Show legends** checkbox.
- 7 Find the **Include** subsection. Select the **Label** checkbox.
- 8 Clear the **Point** checkbox.
- 9 Clear the **Solution** checkbox.
- 10 In the **Sound Pressure Levels** toolbar, click  **Plot**.

The image should look like [Figure 4](#).

#### *Perfectly Matched Layer Distance Function*

- 1 In the **Results** toolbar, click  **3D Plot Group**.
- 2 In the **Settings** window for **3D Plot Group**, type Perfectly Matched Layer Distance Function in the **Label** text field.
- 3 Locate the **Color Legend** section. Select the **Show units** checkbox.

#### *Multislice 1*

- 1 In the **Perfectly Matched Layer Distance Function** toolbar, click  **More Plots** and choose **Multislice**.
- 2 In the **Settings** window for **Multislice**, locate the **Expression** section.
- 3 In the **Expression** text field, type `pm11.dDist`.
- 4 Locate the **Coloring and Style** section. From the **Color table** list, choose **Rainbow**.
- 5 From the **Scale** list, choose **Linear**.
- 6 In the **Perfectly Matched Layer Distance Function** toolbar, click  **Plot**.

#### *Multislice 2*

- 1 Right-click **Multislice 1** and choose **Duplicate**.
- 2 In the **Settings** window for **Multislice**, locate the **Expression** section.
- 3 In the **Expression** text field, type `pm12.dDist`.

- 4 Click to expand the **Title** section. From the **Title type** list, choose **None**.
- 5 Click to expand the **Inherit Style** section. From the **Plot** list, choose **Multislice I**.

#### *Multislice 3*

- 1 Right-click **Multislice 2** and choose **Duplicate**.
- 2 In the **Settings** window for **Multislice**, locate the **Expression** section.
- 3 In the **Expression** text field, type  $\text{sqrt}(\text{pm13}.\text{dDist1}^2 + \text{pm13}.\text{dDist2}^2)$ .
- 4 In the **Perfectly Matched Layer Distance Function** toolbar, click  **Plot**.

The image should look like [Figure 5](#).