



Model created in COMSOL Multiphysics 6.4

Duct with Right-Angled Bend



Introduction

In this tutorial, the acoustic behavior of a duct or waveguide with a right-angled bend is analyzed. The model uses port boundary conditions at the inlet and outlet. The ports can capture and treat nonplane propagating modes in waveguides, extending the analysis above the first cutoff frequency. The transmission loss and the scattering coefficients of the system are determined.

Model Definition

The geometry of the waveguide system analyzed in this model is depicted in [Figure 1](#). It consists of a duct with a right-angled bend in the middle. On the outlet branch, there is also a small dent. The dent is present in order to excite modes that have components in the duct height (the z direction). The width of the duct is W and the height is H ; these are parameters that can be changed. A 2D variant of this tutorial model that studies scattering in a 2D bend is described in [Ref. 1](#).

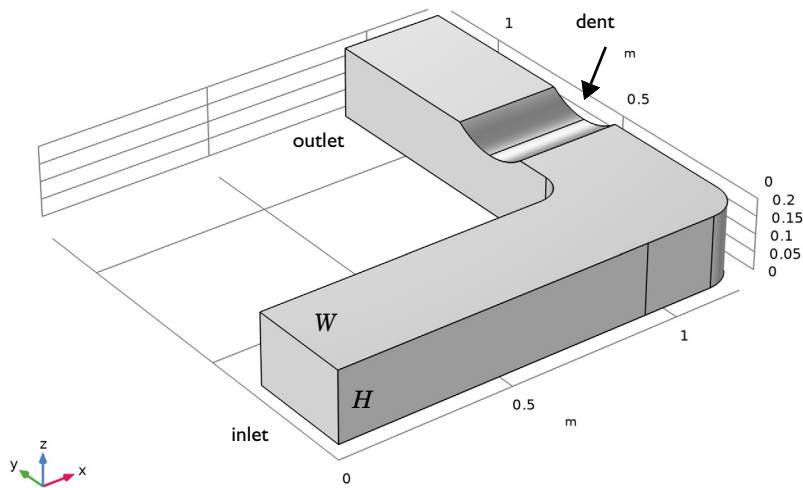

Figure 1: Waveguide geometry consisting of two sections connected by a right-angled bend. A small dent is present on the outlet section.

The model is solved for frequencies in the range from 50 to 1300 Hz. In that range five modes exist: the plane-wave mode (0,0), the first long-edge mode (1,0), the first short-

edge (0,1), the first mixed mode (1,1), and the second long-edge mode (2,0). Their cutoff frequencies are given in Table 1 below (these are derived in the results analysis steps of the model using built-in variables). The mode shapes are depicted in the results section in Figure 6.

TABLE 1: MODE CUTOFF FREQUENCIES.

| Mode (m,n) | Cutoff frequency |
|------------|------------------|
| (0,0) | 0.0 Hz |
| (1,0) | 572.0 Hz |
| (0,1) | 858.0 Hz |
| (1,1) | 1031.2 Hz |
| (2,0) | 1144.0 Hz |

In order to capture these modes and ensure good nonreflecting behavior at the waveguide inlet and outlet, four **Port** boundary conditions are added at each end, each port capturing a specific mode. When solving the model, parts of the solution are the scattering coefficients S_{i1} , where the subscript 1 refers to the fact that the system is excited at port 1 (plane wave incidence at the inlet). This means that on the inlet or outlet boundaries, the combination of ports defines the total acoustic field (sum of incident and outgoing waves, propagating and nonpropagating) as

$$p_t = \sum_{i \in \text{bnd}} (S_{i1} + A^{\text{in}} \delta_{i1}) p_i$$

where the summation “ i ” is over all ports on the given boundary “bnd” (for example 1, 2, 3, 4, and 5 on the inlet), A^{in} is the amplitude of the incident field (1 Pa in this model), and p_i is the mode shape of the i th port. The mode shape p_i is normalized to have a unit maximum amplitude.

A benefit of using the **Port** boundary condition is that important postprocessing variables are readily defined on each port. This includes fields like the total pressure, intensity, and normal velocity, and also global (integrated) variables like the incoming or outgoing power or average pressure. These quantities can in general be difficult to compute when complex nonplane propagation occurs. In this model, the transmission loss TL of the system is calculated as

$$\text{TL} = 10 \log_{10} \left(\frac{P_{\text{in}}}{\sum P_{\text{out}}} \right)$$

where the sum is over all the ports at the outlet. The incident power is simply given by the variable `acpr.port1.P_in` and the sum of the outgoing power as `acpr.port6.P_out+acpr.port7.P_out+acpr.port8.P_out+acpr.port9.P_out+acpr.port10.P_out`.

Results and Discussion

The absolute values of the scattering coefficients $|S_{i1}|$ are depicted in Figure 2 below. The normalized power of the outgoing modes, through the ports, is presented in Figure 3. The graphs shows the cutoff /on of the different modes which is in accordance with the values given in Table 1. Note that the cutoff/on as depicted when plotting $|S_{i1}|$ does not occur as sharply as when visualizing the power. The reason is that pure evanescent modes will contribute to the total field at the port (giving a nonzero S-parameter); while these modes do not carry any real power as they are not propagating.

The transmission loss of the system is depicted in Figure 4. Isosurface plots of the pressure inside the duct is depicted in Figure 5 at four different frequencies, each representing values when one more mode is propagating in the system. The first image at the upper left represents plane wave propagation and so forth. Finally, the five normalized mode shapes are depicted in Figure 6.

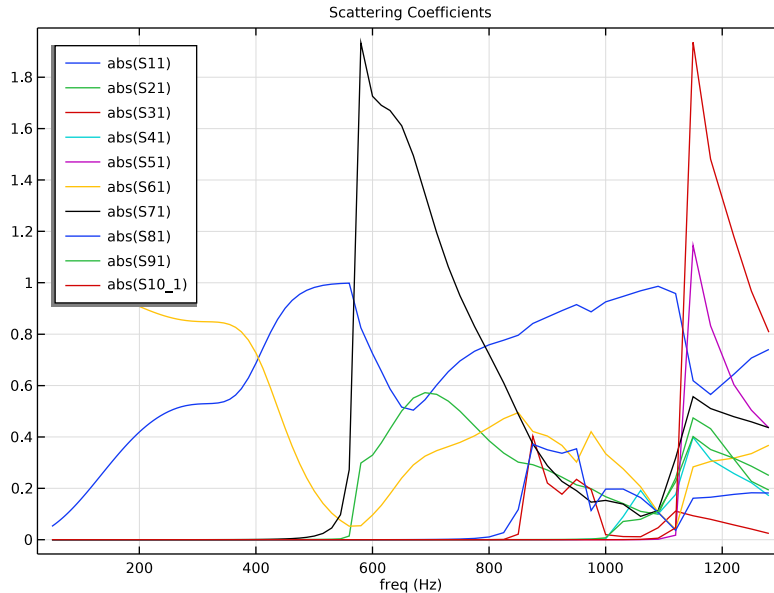

Figure 2: Absolute value of the scattering coefficients as function of frequency.

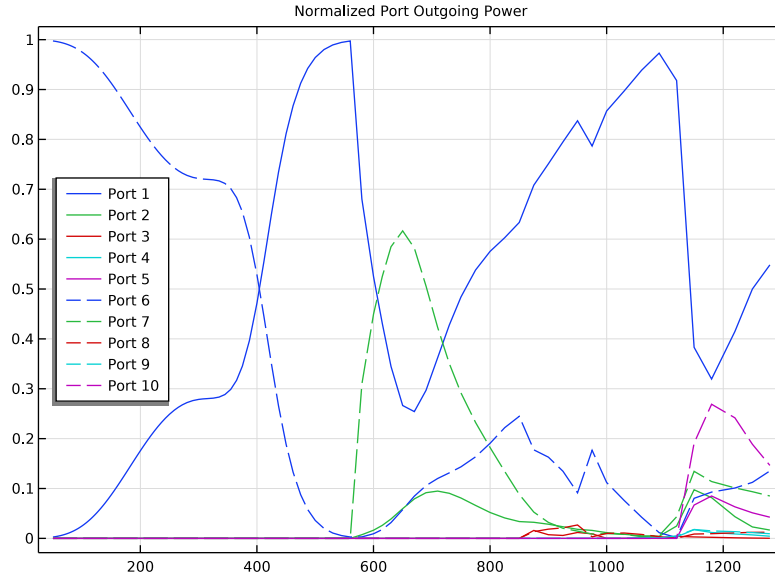

Figure 3: Normalized power of the outgoing modes as function of frequency.

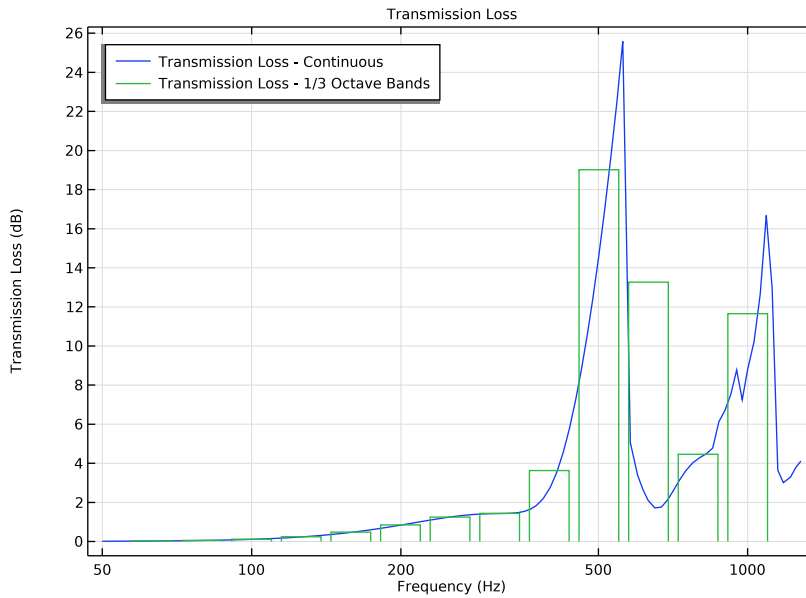

Figure 4: Transmission loss TL through the waveguide system.

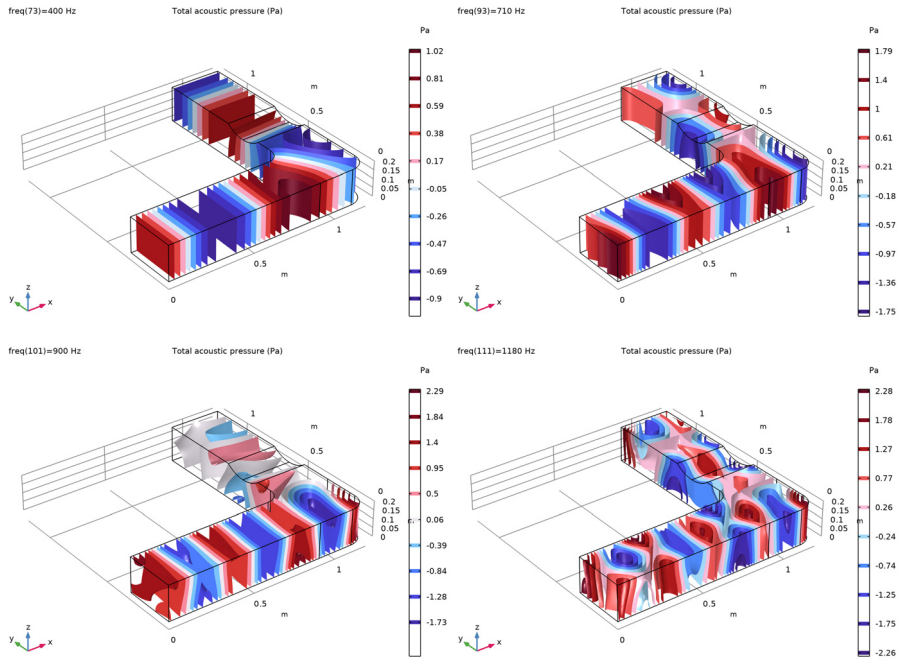

Figure 5: Pressure isosurfaces evaluated at four different frequencies.

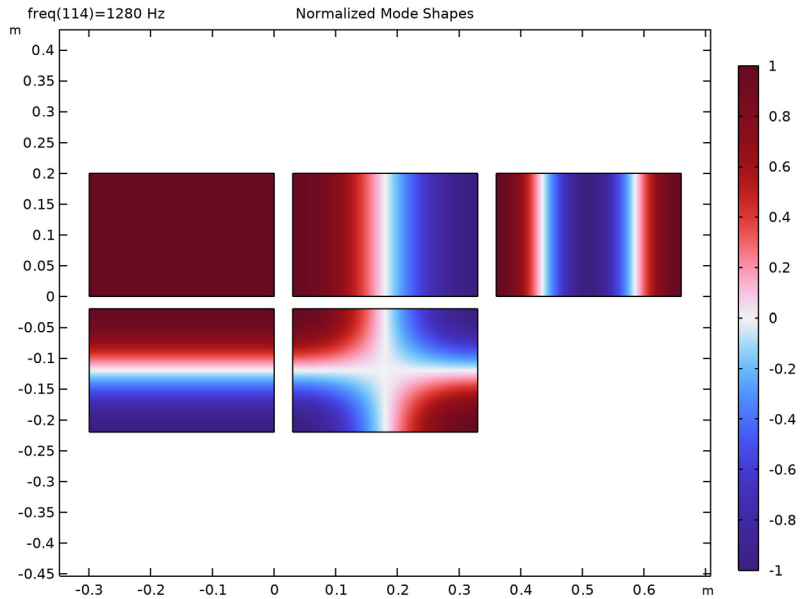

Figure 6: Normalized mode shapes for the five ports.

Reference

1. T. Graf and J. Pan, “Determination of the complex acoustic scattering matrix of a right-angled duct,” *J. Acoust. Soc. Am.*, vol. 134, pp. 292–299, 2013.

Application Library path: Acoustics_Module/Tutorials,_Pressure_Acoustics/duct_right_angled_bend

Modeling Instructions



This section contains the modeling instructions for the Duct with Right-Angled Bend model. They are followed by the [Geometry Sequence Instructions](#) section.

From the **File** menu, choose **New**.

NEW

In the **New** window, click  **Model Wizard**.

MODEL WIZARD

- 1 In the **Model Wizard** window, click  **3D**.
- 2 In the **Select Physics** tree, select **Acoustics > Pressure Acoustics > Pressure Acoustics, Frequency Domain (acpr)**.
- 3 Click **Add**.
- 4 Click  **Study**.
- 5 In the **Select Study** tree, select **General Studies > Frequency Domain**.
- 6 Click  **Done**.

GEOMETRY I

To save some time, import the geometry sequence from a file. The instructions for setting up the geometry can be found in the Geometry Sequence Instructions section at the bottom of this document.

- 1 In the **Geometry** toolbar, click **Insert Sequence** and choose **Insert Sequence**.
- 2 Browse to the model's Application Libraries folder and double-click the file `duct_right_angled_bend_geom_sequence.mph`.
- 3 In the **Geometry** toolbar, click  **Build All**.

GLOBAL DEFINITIONS

Parameters I

- 1 In the **Model Builder** window, under **Global Definitions** click **Parameters I**.
- 2 In the **Settings** window for **Parameters**, locate the **Parameters** section.
- 3 In the table, enter the following settings:

| Name | Expression | Value | Description |
|------------|----------------|-----------|-------------------------|
| f_max | 1300[Hz] | 1300 Hz | Maximum study frequency |
| lambda_min | 343[m/s]/f_max | 0.26385 m | Minimum wavelength |

DEFINITIONS

Create selections for the inlet and outlet of the duct.



Inlet

- 1 In the **Definitions** toolbar, click  **Explicit**.
- 2 In the **Settings** window for **Explicit**, type `Inlet` in the **Label** text field.
- 3 Locate the **Input Entities** section. From the **Geometric entity level** list, choose **Boundary**.

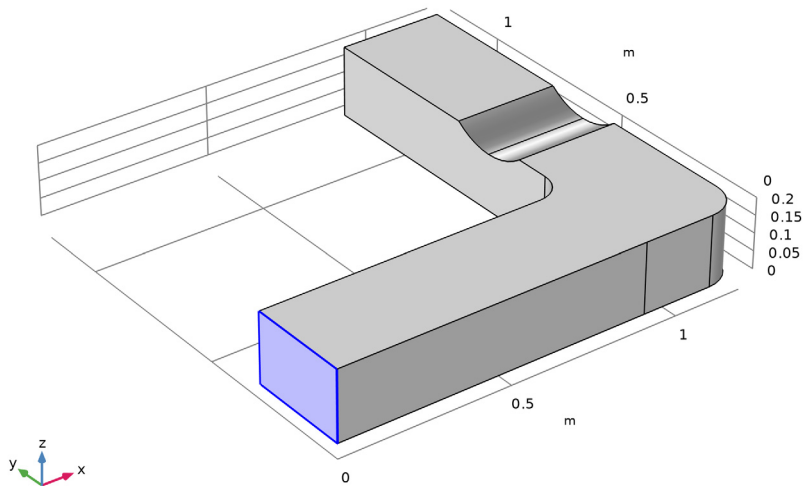
4 Select Boundary 1 only.



Outlet

- 1 In the **Definitions** toolbar, click  **Explicit**.
- 2 In the **Settings** window for **Explicit**, type Outlet in the **Label** text field.
- 3 Locate the **Input Entities** section. From the **Geometric entity level** list, choose **Boundary**.
- 4 Click the  **Wireframe Rendering** button in the **Graphics** toolbar. This simplifies seeing and selecting the outlet boundary.

5 Select Boundary 12 only.

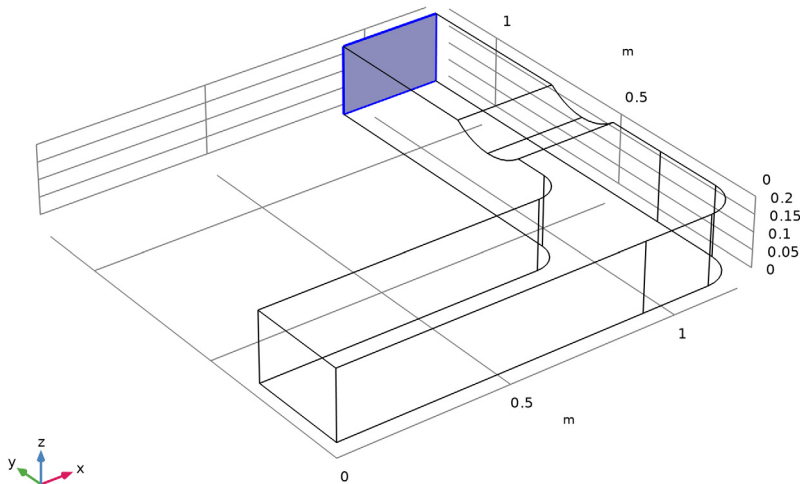

6 Click the  **Wireframe Rendering** button in the **Graphics** toolbar.

ADD MATERIAL

1 In the **Materials** toolbar, click  **Add Material** to open the **Add Material** window.

2 Go to the **Add Material** window.

3 In the tree, select **Built-in > Air**.

4 Click the **Add to Component** button in the window toolbar.

5 In the **Materials** toolbar, click  **Add Material** to close the **Add Material** window.

Proceed to setting up the physics by adding the **Port** boundary conditions to the inlet and the outlet. Use the **Node Group** feature to group the conditions at the inlet and outlet, respectively. This gives a better overview of the model setup.

Add five port conditions at each end of the duct (the waveguide structure). These will capture all propagating modes up to the studied frequency of 1200 Hz. In the postprocessing part of this model you will set up and see a list of the cutoff frequencies of the captured modes. It is always possible to use the Pressure Acoustics, Boundary Mode interface to study and analyze propagating and nonpropagating modes in a waveguide

cross section. See, for example, the `eigenmodes_in_muffler` model in the Automotive application library.

PRESSURE ACOUSTICS, FREQUENCY DOMAIN (ACPR)

Inlet Ports

- 1 In the **Model Builder** window, under **Component 1 (comp1)** right-click **Pressure Acoustics, Frequency Domain (acpr)** and choose **Node Group**.
- 2 In the **Settings** window for **Group**, type `Inlet Ports` in the **Label** text field.

Port 1

- 1 In the **Physics** toolbar, click  **Boundaries** and choose **Port**.
- 2 In the **Settings** window for **Port**, locate the **Boundary Selection** section.
- 3 From the **Selection** list, choose **Inlet**.
- 4 Locate the **Port Properties** section. From the **Type of port** list, choose **Rectangular**.
Use the rectangular (analytical) option that applies to this geometry of a rectangular waveguide with sound hard boundaries. Note that the first port condition that you add has the incident mode option turned on per default, whereas the following are off per default.
- 5 Locate the **Incident Mode Settings** section. In the A_p^{in} text field, type 1.

Port 2

- 1 In the **Physics** toolbar, click  **Boundaries** and choose **Port**.
- 2 In the **Settings** window for **Port**, locate the **Boundary Selection** section.
- 3 From the **Selection** list, choose **Inlet**.
- 4 Locate the **Port Properties** section. From the **Type of port** list, choose **Rectangular**.
- 5 Locate the **Port Mode Settings** section. In the m text field, type 1.

Port 3

- 1 In the **Physics** toolbar, click  **Boundaries** and choose **Port**.
- 2 In the **Settings** window for **Port**, locate the **Boundary Selection** section.
- 3 From the **Selection** list, choose **Inlet**.
- 4 Locate the **Port Properties** section. From the **Type of port** list, choose **Rectangular**.
- 5 Locate the **Port Mode Settings** section. In the n text field, type 1.

Port 4

- 1 In the **Physics** toolbar, click  **Boundaries** and choose **Port**.

- 2 In the **Settings** window for **Port**, locate the **Boundary Selection** section.
- 3 From the **Selection** list, choose **Inlet**.
- 4 Locate the **Port Properties** section. From the **Type of port** list, choose **Rectangular**.
- 5 Locate the **Port Mode Settings** section. In the m text field, type 1.
- 6 In the n text field, type 1.

Port 5

- 1 In the **Physics** toolbar, click  **Boundaries** and choose **Port**.
- 2 In the **Settings** window for **Port**, locate the **Boundary Selection** section.
- 3 From the **Selection** list, choose **Inlet**.
- 4 Locate the **Port Properties** section. From the **Type of port** list, choose **Rectangular**.
- 5 Locate the **Port Mode Settings** section. In the m text field, type 2.
- 6 In the n text field, type 0.

Outlet Ports

- 1 In the **Model Builder** window, right-click **Pressure Acoustics, Frequency Domain (acpr)** and choose **Node Group**.
- 2 In the **Settings** window for **Group**, type Outlet Ports in the **Label** text field.

Port 6

- 1 In the **Physics** toolbar, click  **Boundaries** and choose **Port**.
- 2 In the **Settings** window for **Port**, locate the **Boundary Selection** section.
- 3 From the **Selection** list, choose **Outlet**.
- 4 Locate the **Port Properties** section. From the **Type of port** list, choose **Rectangular**.

Port 7

- 1 In the **Physics** toolbar, click  **Boundaries** and choose **Port**.
- 2 In the **Settings** window for **Port**, locate the **Boundary Selection** section.
- 3 From the **Selection** list, choose **Outlet**.
- 4 Locate the **Port Properties** section. From the **Type of port** list, choose **Rectangular**.
- 5 Locate the **Port Mode Settings** section. In the m text field, type 1.

Port 8

- 1 In the **Physics** toolbar, click  **Boundaries** and choose **Port**.
- 2 In the **Settings** window for **Port**, locate the **Boundary Selection** section.
- 3 From the **Selection** list, choose **Outlet**.

- 4 Locate the **Port Properties** section. From the **Type of port** list, choose **Rectangular**.
- 5 Locate the **Port Mode Settings** section. In the n text field, type 1.

Port 9

- 1 In the **Physics** toolbar, click  **Boundaries** and choose **Port**.
- 2 In the **Settings** window for **Port**, locate the **Boundary Selection** section.
- 3 From the **Selection** list, choose **Outlet**.
- 4 Locate the **Port Properties** section. From the **Type of port** list, choose **Rectangular**.
- 5 Locate the **Port Mode Settings** section. In the m text field, type 1.
- 6 In the n text field, type 1.

Port 10

- 1 In the **Physics** toolbar, click  **Boundaries** and choose **Port**.
- 2 In the **Settings** window for **Port**, locate the **Boundary Selection** section.
- 3 From the **Selection** list, choose **Outlet**.
- 4 Locate the **Port Properties** section. From the **Type of port** list, choose **Rectangular**.
- 5 Locate the **Port Mode Settings** section. In the m text field, type 2.
- 6 In the n text field, type 0.

MESH 1

In this model, the mesh is set up manually. Proceed by directly adding the desired mesh component.

Use a swept mesh to reduce the solving time.

Swept 1

In the **Mesh** toolbar, click  **Swept**.

Size

- 1 In the **Model Builder** window, click **Size**.
- 2 In the **Settings** window for **Size**, locate the **Element Size** section.
- 3 Click the **Custom** button.
- 4 Locate the **Element Size Parameters** section. In the **Maximum element size** text field, type $\lambda_{\min}/5$.



In general, 5 to 6 second-order elements per wavelength are needed to resolve the waves. For more details, see *Meshing (Resolving the Waves)* in the *Acoustics Module User's Guide*. In this model, we use 5 elements per wavelength.

Swept 1

- 1 In the **Model Builder** window, click **Swept 1**.
- 2 In the **Settings** window for **Swept**, click to expand the **Source Faces** section.
- 3 Select Boundaries 4 and 9–11 only.
- 4 Click to expand the **Destination Faces** section. Select Boundary 3 only.
- 5 Locate the **Mesh Generation** section. From the **Elements** list, choose **Prisms**.
- 6 Click  **Build All**.

STUDY 1

Step 1: Frequency Domain

- 1 In the **Model Builder** window, under **Study 1** click **Step 1: Frequency Domain**.
- 2 In the **Settings** window for **Frequency Domain**, locate the **Study Settings** section.
- 3 Click  **Range**.
- 4 In the **Range** dialog, choose **ISO preferred frequencies** from the **Entry method** list.
- 5 In the **Start frequency** text field, type 50.
- 6 In the **Stop frequency** text field, type `f_max`.
- 7 From the **Interval** list, choose **1/24 octave**.
- 8 Click **Replace**.
- 9 In the **Study** toolbar, click  **Compute**.

RESULTS

Take a look at the first three default plots that are generated automatically. They represent the acoustic pressure, the sound pressure level, and isocontours of the pressure, respectively. Change the **Parameter value (freq (Hz))** in the plots to change the evaluation frequency, for example, to 400 Hz.

Acoustic Pressure (acpr)

- 1 In the **Model Builder** window, under **Results** click **Acoustic Pressure (acpr)**.
- 2 In the **Settings** window for **3D Plot Group**, locate the **Data** section.

3 From the **Parameter value (freq (Hz))** list, choose **400**.

freq(73)=400 Hz

Total acoustic pressure (Pa)

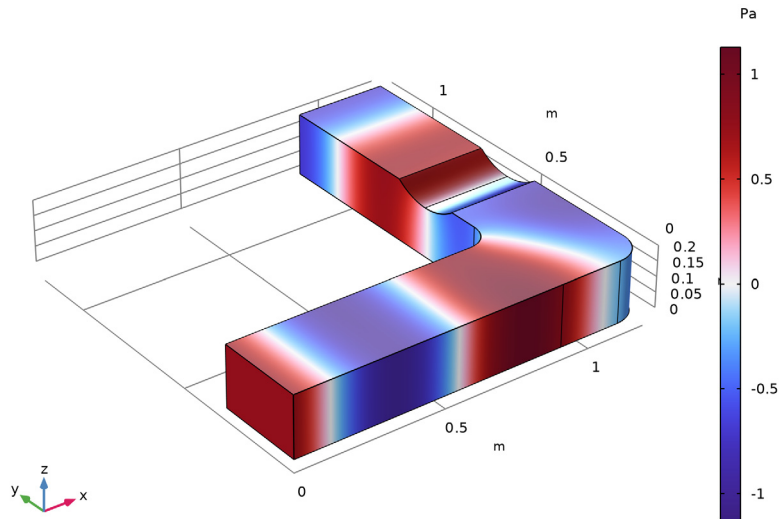

Sound Pressure Level (acpr)

1 In the **Model Builder** window, click **Sound Pressure Level (acpr)**.

2 In the **Settings** window for **3D Plot Group**, locate the **Data** section.

3 From the **Parameter value (freq (Hz))** list, choose **400**.

freq(73)=400 Hz

Total sound pressure level (dB)

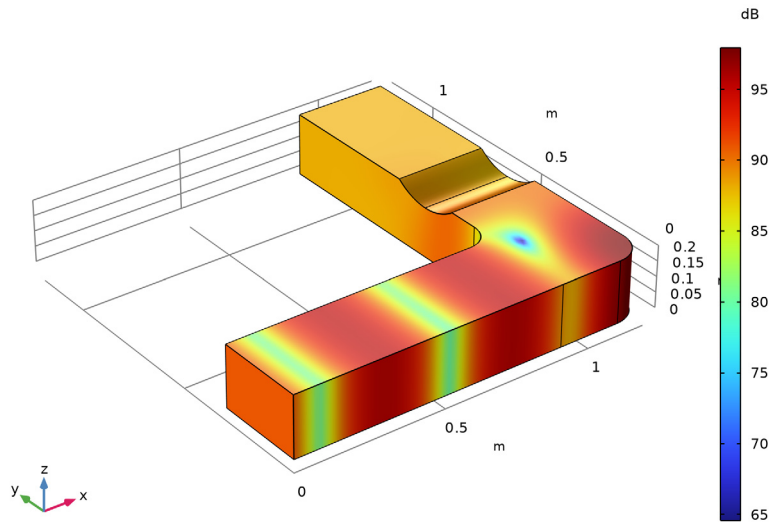

Acoustic Pressure, Isosurfaces (acpr)

- 1** In the **Model Builder** window, click **Acoustic Pressure, Isosurfaces (acpr)**.
- 2** In the **Settings** window for **3D Plot Group**, locate the **Data** section.

3 From the **Parameter value (freq (Hz))** list, choose **400**.

freq(73)=400 Hz

Total acoustic pressure (Pa)

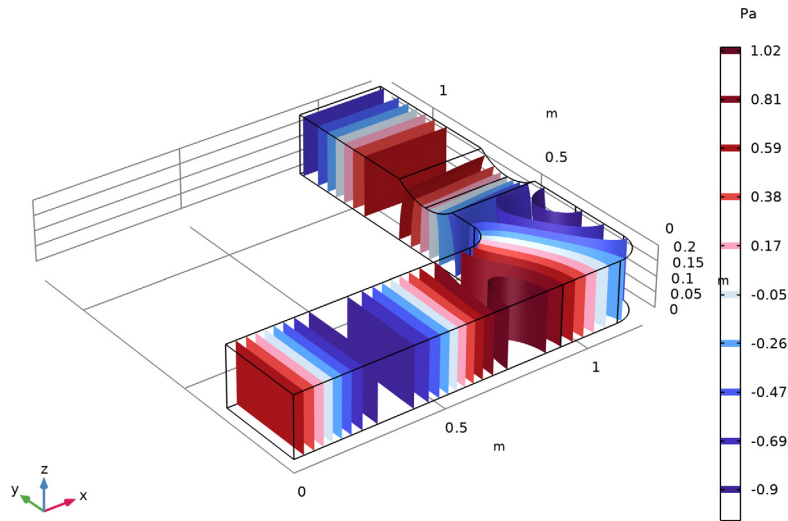

The isosurface plots of the pressure at four different frequencies are also depicted in [Figure 5](#).

Scattering Coefficients

Now proceed and plot the scattering coefficient to reproduce [Figure 2](#).

- 1** In the **Results** toolbar, click  **ID Plot Group**.
- 2** In the **Settings** window for **ID Plot Group**, type **Scattering Coefficients** in the **Label** text field.
- 3** Click to expand the **Title** section. From the **Title type** list, choose **Label**.
- 4** Locate the **Legend** section. From the **Position** list, choose **Upper left**.

Global 1

- 1** Right-click **Scattering Coefficients** and choose **Global**.
- 2** In the **Settings** window for **Global**, locate the **y-Axis Data** section.

3 In the table, enter the following settings:

| Expression | Unit | Description |
|-----------------|------|-------------|
| abs(acpr.S11) | 1 | abs(S11) |
| abs(acpr.S21) | 1 | abs(S21) |
| abs(acpr.S31) | 1 | abs(S31) |
| abs(acpr.S41) | 1 | abs(S41) |
| abs(acpr.S51) | 1 | abs(S51) |
| abs(acpr.S61) | 1 | abs(S61) |
| abs(acpr.S71) | 1 | abs(S71) |
| abs(acpr.S81) | 1 | abs(S81) |
| abs(acpr.S91) | 1 | abs(S91) |
| abs(acpr.S10_1) | 1 | abs(S10_1) |

4 In the **Scattering Coefficients** toolbar, click  **Plot**.

Transmission Loss

Now plot the transmission loss to reproduce [Figure 4](#).

- 1 In the **Results** toolbar, click  **ID Plot Group**.
- 2 In the **Settings** window for **ID Plot Group**, type *Transmission Loss* in the **Label** text field.
- 3 Locate the **Title** section. From the **Title type** list, choose **Label**.
- 4 Locate the **Plot Settings** section.
- 5 Select the **y-axis label** checkbox. In the associated text field, type *Transmission Loss (dB)*.
- 6 Locate the **Legend** section. From the **Position** list, choose **Upper left**.

Octave Band 1

- 1 In the **Transmission Loss** toolbar, click  **More Plots** and choose **Octave Band**.
- 2 In the **Settings** window for **Octave Band**, locate the **Selection** section.
- 3 From the **Geometric entity level** list, choose **Global**.
- 4 Locate the **y-Axis Data** section. In the **Expression** text field, type $\text{acpr.port1.P_in}/(\text{acpr.port6.P_out}+\text{acpr.port7.P_out}+\text{acpr.port8.P_out}+\text{acpr.port9.P_out}+\text{acpr.port10.P_out})$.

This expression gives the ratio of the incoming power (the source at Port 1) and the total outgoing power at the outlet (the sum of the outgoing power of all modes). Note that in general this is not a straightforward quantity to compute for the nonplane

modes. Thus, using the built-in variables for the power (`acpr.port4.P_out` and so on) greatly simplifies postprocessing.

- 5 From the **Expression type** list, choose **Transfer function**.
- 6 Locate the **Plot** section. From the **Quantity** list, choose **Continuous power spectral density**.
- 7 Click to expand the **Legends** section. Select the **Show legends** checkbox.
- 8 From the **Legends** list, choose **Manual**.
- 9 In the table, enter the following settings:

| Legends |
|--------------------------------|
| Transmission Loss - Continuous |

- 10 In the **Transmission Loss** toolbar, click  **Plot**.

Octave Band 2

- 1 Right-click **Octave Band 1** and choose **Duplicate**.
- 2 In the **Settings** window for **Octave Band**, locate the **Plot** section.
- 3 From the **Quantity** list, choose **Band average power spectral density**.
- 4 From the **Band type** list, choose **1/3 octave**.
- 5 Click to expand the **Coloring and Style** section. From the **Type** list, choose **Outline**.
- 6 Locate the **Legends** section. In the table, enter the following settings:

| Legends |
|--------------------------------------|
| Transmission Loss - 1/3 Octave Bands |

- 7 In the **Transmission Loss** toolbar, click  **Plot**.

Surface 1

Now, plot the normalized propagation modes to reproduce [Figure 6](#).

- 1 In the **Model Builder** window, expand the **Results > Datasets** node.
- 2 Right-click **Results > Datasets** and choose **Surface**.
- 3 Select Boundary 1 only.

Normalized Mode Shapes

- 1 In the **Results** toolbar, click  **2D Plot Group**.
- 2 In the **Settings** window for **2D Plot Group**, type Normalized Mode Shapes in the **Label** text field.

- 3 Click to expand the **Title** section. From the **Title type** list, choose **Label**.



Surface 1

- 1 Right-click **Normalized Mode Shapes** and choose **Surface**.
- 2 In the **Settings** window for **Surface**, click **Replace Expression** in the upper-right corner of the **Expression** section. From the menu, choose **Component 1 (comp1) > Pressure Acoustics, Frequency Domain > Ports > Port 1 > acpr.port1.pn - Normalized mode pressure - Pa**.
- 3 In the **Normalized Mode Shapes** toolbar, click  **Plot**.
- 4 Locate the **Coloring and Style** section. From the **Color table** list, choose **Wave**.
- 5 From the **Scale** list, choose **Linear symmetric**.

Surface 2

- 1 Right-click **Surface 1** and choose **Duplicate**.
- 2 In the **Settings** window for **Surface**, locate the **Expression** section.
- 3 In the **Expression** text field, type `acpr.port2.pn`.
- 4 Click to expand the **Inherit Style** section. From the **Plot** list, choose **Surface 1**.

Transformation 1

- 1 Right-click **Surface 2** and choose **Transformation**.
- 2 In the **Settings** window for **Transformation**, locate the **Transformation** section.
- 3 In the **x** text field, type `1.1*W`.
- 4 In the **Normalized Mode Shapes** toolbar, click  **Plot**.
- 5 Click the  **Zoom Extents** button in the **Graphics** toolbar.

Surface 3

- 1 In the **Model Builder** window, under **Results > Normalized Mode Shapes** right-click **Surface 2** and choose **Duplicate**.
- 2 In the **Settings** window for **Surface**, locate the **Expression** section.
- 3 In the **Expression** text field, type `acpr.port3.pn`.

Transformation 1



- 1 In the **Model Builder** window, expand the **Surface 3** node, then click **Transformation 1**.
- 2 In the **Settings** window for **Transformation**, locate the **Transformation** section.
- 3 In the **x** text field, type `0`.
- 4 In the **y** text field, type `-1.1*H`.
- 5 In the **Normalized Mode Shapes** toolbar, click  **Plot**.

6 Click the  **Zoom Extents** button in the **Graphics** toolbar.

Surface 4

- 1 In the **Model Builder** window, under **Results** > **Normalized Mode Shapes** right-click **Surface 3** and choose **Duplicate**.
- 2 In the **Settings** window for **Surface**, locate the **Expression** section.
- 3 In the **Expression** text field, type `acpr.port4.pn`.



Transformation 1

- 1 In the **Model Builder** window, expand the **Surface 4** node, then click **Transformation 1**.
- 2 In the **Settings** window for **Transformation**, locate the **Transformation** section.
- 3 In the **x** text field, type `1.1*W`.
- 4 In the **Normalized Mode Shapes** toolbar, click  **Plot**.
- 5 Click the  **Zoom Extents** button in the **Graphics** toolbar.

Surface 5

- 1 In the **Model Builder** window, under **Results** > **Normalized Mode Shapes** right-click **Surface 4** and choose **Duplicate**.
- 2 In the **Settings** window for **Surface**, locate the **Expression** section.
- 3 In the **Expression** text field, type `acpr.port5.pn`.

Transformation 1

- 1 In the **Model Builder** window, expand the **Surface 5** node, then click **Transformation 1**.
- 2 In the **Settings** window for **Transformation**, locate the **Transformation** section.
- 3 In the **x** text field, type `2.2*W`.
- 4 In the **y** text field, type `0`.
- 5 In the **Normalized Mode Shapes** toolbar, click  **Plot**.
- 6 Click the  **Zoom Extents** button in the **Graphics** toolbar.

Cutoff Frequencies

- 1 In the **Results** toolbar, click  **Evaluation Group**.
- 2 In the **Settings** window for **Evaluation Group**, type **Cutoff Frequencies** in the **Label** text field.
- 3 Locate the **Data** section. From the **Parameter selection (freq)** list, choose **First**.

Global Evaluation 1

- 1 Right-click **Cutoff Frequencies** and choose **Global Evaluation**.

- In the **Settings** window for **Global Evaluation**, click **Replace Expression** in the upper-right corner of the **Expressions** section. From the menu, choose **Component 1 (comp1) > Pressure Acoustics, Frequency Domain > Ports > Port 1 > acpr.port1.fc - Mode cutoff frequency - Hz**.

Modify the first description to reflect which mode it refers to and then add the other cutoff frequency variables. These values are also discussed in the results section of the model description.

- Locate the **Expressions** section. In the table, enter the following settings:

| Expression | Unit | Description |
|---------------|------|-----------------------------|
| acpr.port1.fc | Hz | Mode (0,0) cutoff frequency |
| acpr.port2.fc | Hz | Mode (1,0) cutoff frequency |
| acpr.port3.fc | Hz | Mode (0,1) cutoff frequency |
| acpr.port4.fc | Hz | Mode (1,1) cutoff frequency |
| acpr.port5.fc | Hz | Mode (2,0) cutoff frequency |

- In the **Cutoff Frequencies** toolbar, click  **Evaluate**.

Normalized Port Outgoing Power

Now, plot the normalized power of the outgoing modes.

- In the **Results** toolbar, click  **ID Plot Group**.
- In the **Settings** window for **ID Plot Group**, type **Normalized Port Outgoing Power** in the **Label** text field.
- Locate the **Title** section. From the **Title type** list, choose **Label**.
- Locate the **Legend** section. From the **Position** list, choose **Middle left**.

Global 1

- Right-click **Normalized Port Outgoing Power** and choose **Global**.
- In the **Settings** window for **Global**, locate the **y-Axis Data** section.
- In the table, enter the following settings:

| Expression | Unit | Description |
|----------------------------------|------|-------------|
| acpr.port1.P_out/acpr.port1.P_in | 1 | Port 1 |
| acpr.port2.P_out/acpr.port1.P_in | 1 | Port 2 |
| acpr.port3.P_out/acpr.port1.P_in | 1 | Port 3 |
| acpr.port4.P_out/acpr.port1.P_in | 1 | Port 4 |
| acpr.port5.P_out/acpr.port1.P_in | 1 | Port 5 |

Global 2

- 1 Right-click **Global 1** and choose **Duplicate**.
- 2 In the **Settings** window for **Global**, locate the **y-Axis Data** section.
- 3 In the table, enter the following settings:

| Expression | Unit | Description |
|-----------------------------------|------|-------------|
| acpr.port6.P_out/acpr.port1.P_in | 1 | Port 6 |
| acpr.port7.P_out/acpr.port1.P_in | 1 | Port 7 |
| acpr.port8.P_out/acpr.port1.P_in | 1 | Port 8 |
| acpr.port9.P_out/acpr.port1.P_in | 1 | Port 9 |
| acpr.port10.P_out/acpr.port1.P_in | 1 | Port 10 |

- 4 Click to expand the **Coloring and Style** section. Find the **Line style** subsection. From the **Line** list, choose **Dashed**.
- 5 From the **Color** list, choose **Cycle (reset)**.
- 6 In the **Normalized Port Outgoing Power** toolbar, click  **Plot**.

Geometry Sequence Instructions

From the **File** menu, choose **New**.

NEW

In the **New** window, click  **Blank Model**.

GLOBAL DEFINITIONS

Parameters 1

- 1 In the **Model Builder** window, under **Global Definitions** click **Parameters 1**.
- 2 In the **Settings** window for **Parameters**, locate the **Parameters** section.
- 3 In the table, enter the following settings:

| Name | Expression | Value | Description |
|-------|------------|--------|----------------------------|
| L | 120[cm] | 1.2 m | Waveguide length |
| W | 30[cm] | 0.3 m | Waveguide width |
| H | 20[cm] | 0.2 m | Waveguide height |
| Rcurv | 8[cm] | 0.08 m | Bend curvature radius |
| Rcyl | 20[cm] | 0.2 m | Cylinder radius (for dent) |

ADD COMPONENT

In the **Home** toolbar, click  **Add Component** and choose **3D**.

GEOMETRY I

Work Plane 1 (wp1)

In the **Geometry** toolbar, click  **Work Plane**.

Work Plane 1 (wp1) > Rectangle 1 (r1)

1 In the **Work Plane** toolbar, click  **Rectangle**.

2 In the **Settings** window for **Rectangle**, locate the **Size and Shape** section.

3 In the **Width** text field, type L.

4 In the **Height** text field, type W.

Work Plane 1 (wp1) > Rectangle 2 (r2)

1 In the **Work Plane** toolbar, click  **Rectangle**.

2 In the **Settings** window for **Rectangle**, locate the **Size and Shape** section.

3 In the **Width** text field, type W.

4 In the **Height** text field, type L.

5 Locate the **Position** section. In the **xw** text field, type L-W.

Work Plane 1 (wp1) > Union 1 (uni1)

1 In the **Work Plane** toolbar, click  **Booleans and Partitions** and choose **Union**.

2 Click in the **Graphics** window and then press Ctrl+A to select both objects.

3 In the **Settings** window for **Union**, locate the **Union** section.

4 Clear the **Keep interior boundaries** checkbox.

5 Click  **Build Selected**.

Work Plane 1 (wp1) > Fillet 1 (fil1)

1 In the **Work Plane** toolbar, click  **Fillet**.

2 On the object **uni1**, select Point 4 only.



3 In the **Settings** window for **Fillet**, locate the **Radius** section.

4 In the **Radius** text field, type Rcurv.

Work Plane 1 (wp1) > Fillet 2 (fil2)

1 In the **Work Plane** toolbar, click  **Fillet**.

2 On the object **fil1**, select Point 7 only.

- 3 In the **Settings** window for **Fillet**, locate the **Radius** section.
- 4 In the **Radius** text field, type $1.2 \cdot R_{curv}$.
- 5 Click  **Build Selected**.
- 6 Click the  **Zoom Extents** button in the **Graphics** toolbar.

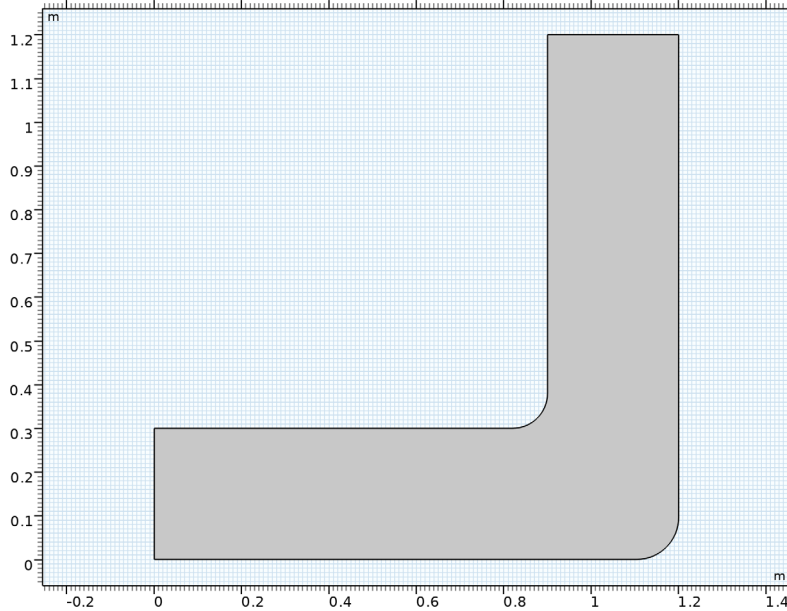

Extrude 1 (ext1)

- 1 In the **Model Builder** window, under **Component 1 (comp1) > Geometry 1** right-click **Work Plane 1 (wp1)** and choose **Extrude**.
- 2 In the **Settings** window for **Extrude**, locate the **Distances** section.
- 3 In the table, enter the following settings:

| Distances (m) |
|---------------|
| H |





- 4 Click  **Build Selected**.

Cylinder 1 (cyl1)

- 1 In the **Geometry** toolbar, click  **Cylinder**.
- 2 In the **Settings** window for **Cylinder**, locate the **Size and Shape** section.
- 3 In the **Radius** text field, type R_{cyl1} .

- 4 Locate the **Position** section. In the **x** text field, type $L/2$.
- 5 In the **y** text field, type $L/2$.
- 6 In the **z** text field, type $H+0.8 \cdot R \cos 1$.
- 7 Locate the **Axis** section. From the **Axis type** list, choose **x-axis**.

Difference 1 (dif1)

- 1 In the **Geometry** toolbar, click  **Booleans and Partitions** and choose **Difference**.
- 2 Select the object **ext1** only.
- 3 In the **Settings** window for **Difference**, locate the **Difference** section.
- 4 Click to select the  **Activate Selection** toggle button for **Objects to subtract**.
- 5 Select the object **cyll** only.
- 6 Click  **Build All Objects**.
- 7 Click the  **Zoom Extents** button in the **Graphics** toolbar.

