



Model created in COMSOL Multiphysics 6.4

Axisymmetric Condenser Microphone

Introduction

This is a model of a condenser microphone with a simple axisymmetric geometry. The model aims to give a precise description of the physical working principles of such a microphone. The simulation results in the sensitivity curve of the transducer, that is, the transformation from detected pressure to measured voltage. The model also predicts the DC and AC capacitance of the microphone.

The condenser microphone is considered to be the microphone with highest quality when performing precise acoustical measurements and with high-fidelity reproduction properties when performing sound recordings; see Ref. 2. This electromechanical acoustic transducer works by transforming the mechanical deformation of a thin membrane (diaphragm) into an AC voltage signal.

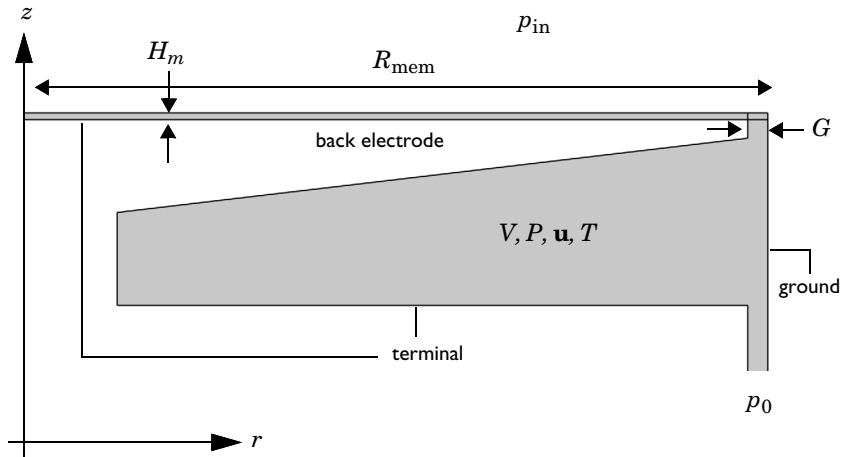

Figure 1: Sketch of the condenser microphone system (axisymmetric geometry) including variables and coordinate system.

Models for describing condenser microphones have classically been of the equivalent network type; see Ref. 2. Analytical models exist for simpler geometries, but there are also highly advanced analytical models for more complex geometries; see for example Ref. 1 or Ref. 4. In the present detailed finite-element model, the thermoviscous acoustic, electric, and structural problem is solved fully coupled using the frequency-domain linear perturbation solver. This includes the DC charging (prepolarization) and deformation of the membrane which makes out the zeroth order linearization point. A small external circuit model is added to model the preamplifier (voltage source and resistor) connected to the terminal. In some cases, lumping of the electrical part is a good approximation,

especially for simple geometries such as this one, where the back electrode is flat and has no perforations. During the initial design steps, lumped models are an important tool. In more complex geometries, solving the full set of equations is necessary to get the correct response.

THEORETICAL MEMBRANE MODEL

In order to compare the results of the simulation, the model uses the analytical solution derived for an undamped axisymmetric membrane. The displacement U of a thin axisymmetric membrane of thickness t_m , under constant tension T_m , and with a density ρ_m is governed by the following equation

$$T_m \frac{\partial}{\partial r} \left(r \frac{\partial U}{\partial r} \right) - \rho_{ms} r \frac{\partial^2 U}{\partial t^2} - r F_s = 0 \quad (1)$$

where r is the radial coordinate, t is time, $\rho_{ms} = \rho_m/t_m$ is the surface density, and F_s is the sum of surface forces; see for example [Ref. 3](#). In the present model, the surface force is the sum of the external incident pressure p_{in} (it is assumed to be uniform over the microphone membrane), the internal pressure $p = p(\mathbf{r})$ (given by the thermoviscous acoustics model), and the electrostatic force which is the sum of the quiescent Maxwell surface stress $\mathbf{n} \cdot \boldsymbol{\tau}$ (given by the electrostatic model) and the small-signal force f_{es} . The variation of the deformation U is assumed to be small and harmonic on top of the static contribution U_0 from the DC polarization, such that

$$\begin{aligned} U(\mathbf{r}, t) &= U_0(\mathbf{r}) + U(\mathbf{r})e^{i\omega t} \\ p_{in}(\mathbf{r}, t) &= p_{in}e^{i\omega t} \\ p(\mathbf{r}, t) &= p(\mathbf{r})e^{i\omega t} \\ F_{es}(\mathbf{r}, t) &= \mathbf{n} \cdot \boldsymbol{\tau} + f_{es}/(2\pi R_m^2) \cdot e^{i\omega t} \end{aligned} \quad (2)$$

Using these expressions, [Equation 1](#) is reformulated into a static and a time-harmonic equation as

$$\begin{aligned} T_m \frac{\partial}{\partial r} \left(r \frac{\partial U_0}{\partial r} \right) - r(\mathbf{n} \cdot \boldsymbol{\tau}) &= 0 \\ T_m \frac{\partial}{\partial r} \left(r \frac{\partial U}{\partial r} \right) + \rho_{ms} r \omega^2 U - r(f_{es}/(2\pi R_{mem}^2) + p_{in} - p) &= 0 \end{aligned} \quad (3)$$

The latter equation may be rewritten in terms of the axial velocity, $u_m = i\omega U$, of the membrane in the form of a Helmholtz equation:

$$\Gamma_m \frac{\partial}{\partial r} \left(r \frac{\partial u_m}{\partial r} \right) + \Gamma_m k_m^2 r u_m - i \omega r (p_{in} - p) = 0 \quad (4)$$

$$k_m^2 = \frac{\omega^2 \rho_{ms}}{T_m}$$

Here k_m is the membrane wave number. In this model, you disregard the change in tension due to the movement of the membrane, which is a nonlinear effect that is small compared to the tension T_m .

The current model represents a true multiphysics problem that involves several physics interfaces: Thermoviscous Acoustics, Electrostatics, Electrical Circuit, a Membrane model and the Moving Mesh feature. The analytical solution of the above equation is shown for comparison in the results section.

Note: This application requires the AC/DC Module and the Structural Mechanics Module in addition to the Acoustics Module.

Model Definition

The geometry and model definitions are shown in [Figure 1](#). In many microphones there is a back-volume below the electrode. In this model, a simplified generic back volume geometry is used and a pressure release condition is applied with $p_0 = 0$ Pa (at the vent). In many commercial microphones the back plate (or back electrode) is perforated to achieve a controlled damping of the membrane, this is not modeled here. The membrane is deformed due to the electrostatic forces from charging the capacitor and because of the pressure variation from the external incoming uniform acoustic signal p_{in} . The chosen dimensions of the microphone are typical generic dimensions. Dimensions and parameters are given in [Table 1](#).

TABLE 1: MICROPHONE DIMENSIONS AND PARAMETERS.

SYMBOL	SIZE & UNIT	DESCRIPTION
H_m	18 μm	Air gap thickness
R_{mem}	2 mm	Membrane radius
G	54 μm	Slit gap width
T_{m0}	3150 N/m	Membrane static tension
E_m	221 GPa	Membrane elastic modulus

TABLE 1: MICROPHONE DIMENSIONS AND PARAMETERS.

SYMBOL	SIZE & UNIT	DESCRIPTION
t_m	7 μm	Membrane thickness
ρ_m	8300 kg/m^3	Membrane density
V_{pol}	100 V	Target polarization voltage
R_{preamp}	1 $\text{G}\Omega$	Preamplifier output impedance
ν_m	0.4	Poisson's ratio for the membrane

The membrane is backed by a thin air gap of thickness H_m and a back electrode. Because the gap is so small, the inclusion of thermal and viscous losses in the acoustic model is essential, thus using the thermoviscous acoustics interface. The membrane and back electrode make up a capacitor that is polarized by an external DC voltage source through the preamplifier resistance R_{preamp} . This will give rise to a surface charge Q_m . The air gap acts as a damping layer for the membrane vibrations (compressible squeeze film damping). As the gap between the membrane and the back electrode varies, a voltage change is induced. The coupling between the electric and mechanical domain is achieved using moving mesh, also for the time harmonic frequency domain study. This AC voltage is the output of the microphone.

The sensitivity of the condenser microphone L , is measured in the unit dB (relative to 1 V/Pa). It is defined as the ratio of the open circuit output voltage V_{out} to the input pressure p_{in} and is given by

$$L = 20 \log \left[\left| \frac{V_{\text{out}}}{p_{\text{in}}} \right| / \left(1 \frac{\text{V}}{\text{Pa}} \right) \right] \quad (5)$$

In the present model, the membrane (or diaphragm) is modeled using the dedicated Membrane interface from the Structural Mechanics Module. The membrane is subject to a surface load that is the sum of the external incident pressure p_{in} , the internal surface stress (given by the thermoviscous acoustics model), and the electrostatic force given by the Maxwell surface stress, $\mathbf{n} \cdot \boldsymbol{\tau}$. The incident pressure is here assumed to be uniform over the microphone membrane, which is only an approximation. At the highest frequencies modeled, the acoustic wavelength becomes comparable with the membrane radius.

When computing the capacitance of the microphone the incident pressure is disabled and an AC voltage source is applied across the microphone. For numerical reasons the voltage cannot be applied directly, but is applied through a resistor with a very small resistance.

Results and Discussion

This model involves a detailed description of the physical effects in a simple condenser microphone. The sensitivity of the microphone L , is directly determined from the model (voltage on the terminal divided by the incident pressure) and is shown in Figure 2 below. Notice the slight roll-off at the low frequencies, this is due to the interaction with the preamplifier circuit. By increasing the output impedance R_{preamp} this effect will disappear, if the value is decreased, the roll-off will be more significant.

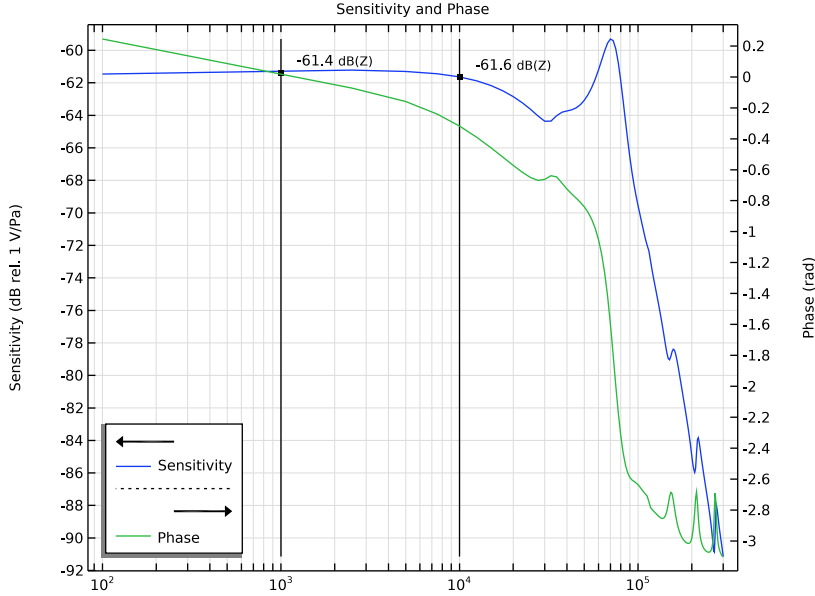

Figure 2: Sensitivity curve of the microphone measured in dB relative to 1 V/Pa.

For the case of the simple geometry used in this model, an analytical solution exists for the dynamics of the undamped membrane; see Ref. 3. The axial displacement is given by

$$U_{\text{th}}(r) = \frac{P_{\text{in}}}{T_{\text{m}} k_{\text{m}}^2} \left(1 - \frac{J_0(k_{\text{m}} r)}{J_0(k_{\text{m}} R_{\text{mem}})} \right) \quad (6)$$

where k_{m} is the wave number defined in Equation 4. The analytical approximation is compared to the model results in Figure 3, which shows the average deformation versus frequency. The results agree well below the resonance frequency of the system. The average behavior above the first resonance (in between resonances) is also well captured by the approximate theoretical model. In the real system, the damping introduced by the

thermal and viscous losses in the air gap is important, especially at the resonances. This is also seen from the figure, where the resonance of the full (real) system is damped and shifted in frequency. The comparison of the two is used as an extra indicator for the correctness of the COMSOL model.

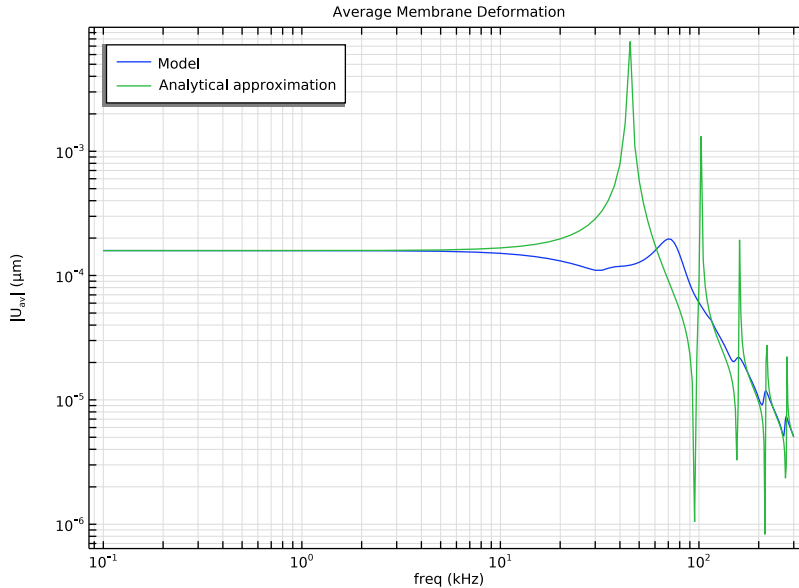

Figure 3: Comparison of the average membrane deformation given by the COMSOL model and by the theoretical approximation for the undamped membrane.

The shape of the deformed membrane and internal pressure is plotted for $f = 300$ kHz as a 3D surface in Figure 4, using a revolution 2D dataset. At this frequency, it is clear to see how higher order modes in the membrane are the cause of the poor sensitivity.

In the second study of the model the capacitance of the microphone is computed. The results are shown in Figure 5 (see Ref. 5). The plot shows the DC (stationary) capacitance as well as the AC (frequency) capacitance curves. At low frequencies the AC values are higher than the DC reference, and then at higher frequencies the AC capacitance approaches the DC value.

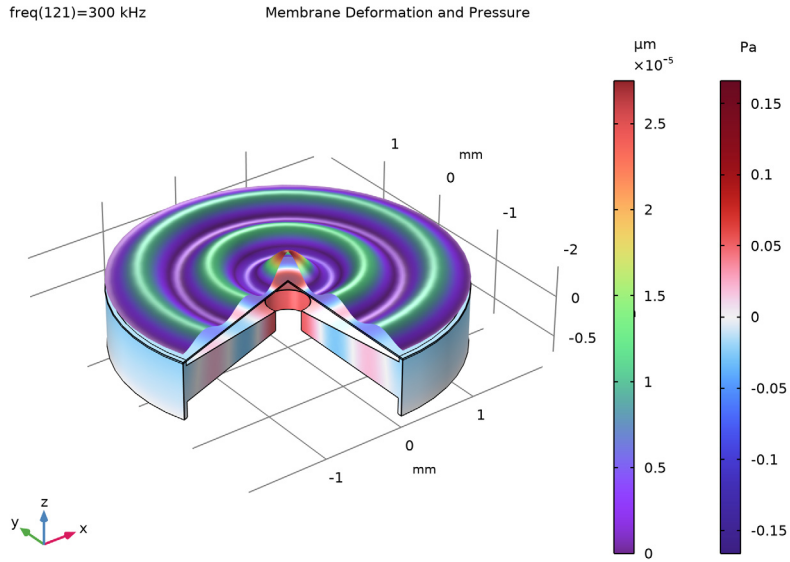

Figure 4: 3D representation of the harmonic membrane deformation at 300 kHz.

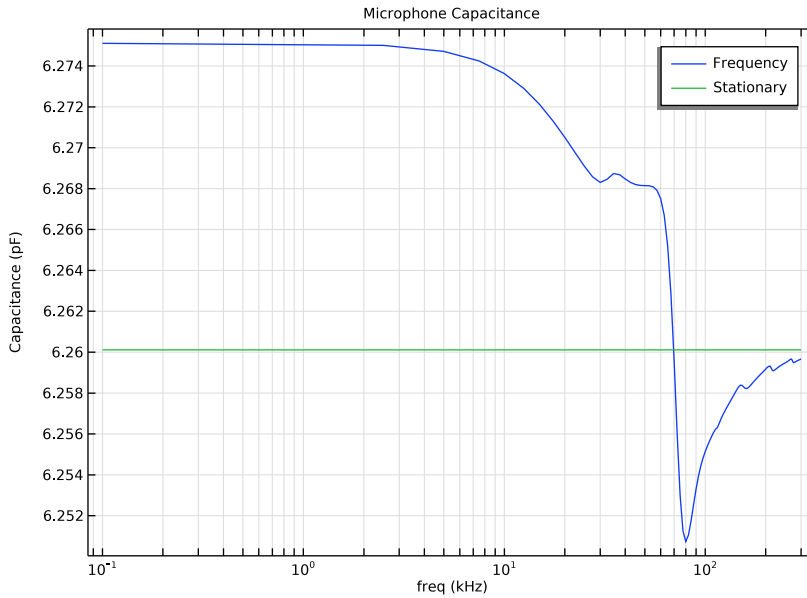

Figure 5: The AC (frequency) and DC (stationary) capacitance of the microphone.

The principles described in this model can be extended to 3D models with more complex geometries. Because the full set of equations is solved, such a model includes all physical effects to a high degree of detail. For example, as in [The Brüel & Kjør 4134 Condenser Microphone](#). It can be used to optimize the performance of microphones, to make virtual tests of new geometries, or to investigate the relative importance of different parameters.

Notes About the COMSOL Implementation

COUPLED STATIC AND FREQUENCY-DOMAIN MODEL USING THE FREQUENCY DOMAIN, PRESTRESSED STUDY

The current model solves a fully coupled problem using the Frequency Domain, Prestressed study. A stationary study determines the linearization point and the full system of equations is then linearized and solved around this point to determine the harmonic small-signal response (the Frequency Domain Perturbation study step).

The first step is to determine the linearization point for the problem which requires solving a static model that determines the shape of the membrane after the polarization voltage and the membrane tension are applied. The first step solves the electrostatic model (using the Electrostatics interface in the AC/DC Module) coupled to the membrane model. The acoustic model is automatically deactivated as it is, per construction, a small perturbation and thus has no contribution to the static solver step. To determine the correct capacitance (and electric fields) a Moving Mesh feature is needed. The capacitance is a geometry-dependent quantity.

The second step is to solve the linear perturbation frequency-domain model that describes the time-harmonic small-signal deformation of the membrane and the interaction with the fluid (described by a Thermoviscous Acoustics, Frequency Domain interface) within the microphone.

References

1. T. Lavergne, S. Durand, M. Bruneau, N. Joly, and D. Rodrigues, “Dynamic behavior of the circular membrane of an electrostatic microphone: Effect of holes in the backing electrode,” *J. Acoust. Soc. Am.*, vol. 128, p. 3459, 2010.
2. W. Marshall Leach, Jr., *Introduction to Electroacoustics and Audio Amplifier Design*, 3rd ed., Kendall/Hunt Publishing Company, 2003.
3. P.M. Morse and K. Uno Ignard, *Theoretical Acoustics*, Princeton University Press, 1968.

4. V.C. Henriquez, *Numerical Transducer Modelling*, PhD Thesis, DTU, November 2001.

5. M. J. Herring Jensen and E. S Olsen, “Virtual prototyping of condenser microphones using the finite element method for detailed electric, mechanic, and acoustic characterization,” *Proc. Mtgs. Acoust.*, vol. 19, 030039, 2013.

Application Library path: Acoustics_Module/Electroacoustic_Transducers/
condenser_microphone

Modeling Instructions

From the **File** menu, choose **New**.

NEW

In the **New** window, click  **Model Wizard**.

MODEL WIZARD

- 1 In the **Model Wizard** window, click  **2D Axisymmetric**.
- 2 In the **Select Physics** tree, select **AC/DC > Electric Fields and Currents > Electrostatics (es)**.
- 3 Click **Add**.

This is an appropriate choice because it is a good assumption that the electric processes in this model are quasistatic.
- 4 In the **Select Physics** tree, select **AC/DC > Electrical Circuit (cir)**.
- 5 Click **Add**.
- 6 In the **Select Physics** tree, select **Acoustics > Thermoviscous Acoustics > Thermoviscous Acoustics, Frequency Domain (ta)**.
- 7 Click **Add**.
- 8 In the **Select Physics** tree, select **Structural Mechanics > Membrane (mbrn)**.
- 9 Click **Add**.
- 10 In the **Displacement field (m)** text field, type um.

11 In the **Displacement field components** table, enter the following settings:

um
vm
wm

The displacement field of the membrane is (um,vm,wm) while the velocity field in the fluid is (u,v,w).

12 Click  **Study**.

13 In the **Select Study** tree, select **Preset Studies for Selected Physics Interfaces > Membrane > Frequency Domain, Prestressed**.

14 Click  **Done**.

GLOBAL DEFINITIONS

Parameters 1

1 In the **Model Builder** window, under **Global Definitions** click **Parameters 1**.

2 In the **Settings** window for **Parameters**, locate the **Parameters** section.

3 Click  **Load from File**.

4 Browse to the model's Application Libraries folder and double-click the file `condenser_microphone_parameters.txt`.

These are the parameters specifying the geometry and the physical properties of the microphone and membrane.

GEOMETRY 1

1 In the **Model Builder** window, under **Component 1 (comp1)** click **Geometry 1**.

2 In the **Settings** window for **Geometry**, locate the **Units** section.

3 From the **Length unit** list, choose **mm**.

Rectangle 1 (r1)

1 In the **Geometry** toolbar, click  **Rectangle**.



2 In the **Settings** window for **Rectangle**, locate the **Size and Shape** section.

3 In the **Width** text field, type Rmem.

4 In the **Height** text field, type Hm.

5 Click  **Build Selected**.



Rectangle 2 (r2)

- 1 In the **Geometry** toolbar, click  **Rectangle**.
- 2 In the **Settings** window for **Rectangle**, locate the **Size and Shape** section.
- 3 In the **Width** text field, type G.
- 4 In the **Height** text field, type Hm.
- 5 Locate the **Position** section. In the **r** text field, type Rmem-G.
- 6 Click  **Build Selected**.

Polygon 1 (pol1)

- 1 In the **Geometry** toolbar, click  **Polygon**.
- 2 In the **Settings** window for **Polygon**, locate the **Coordinates** section.
- 3 In the table, enter the following settings:

r (mm)	z (mm)
Rmem-G	0
Rmem-G	-0.05
0.25	-0.25
0.25	-0.5
Rmem-G	-0.5
Rmem-G	-0.7
Rmem	-0.7
Rmem	0
Rmem-G	0

- 4 Click  **Build All Objects**.
- 5 Click the  **Zoom Extents** button in the **Graphics** toolbar.

DEFINITIONS

Create a selection corresponding to the membrane for use when adding features to the membrane edge.

Membrane

- 1 In the **Definitions** toolbar, click  **Explicit**.
- 2 In the **Settings** window for **Explicit**, locate the **Input Entities** section.
- 3 From the **Geometric entity level** list, choose **Boundary**.
- 4 Select Boundaries 3 and 12 only.

5 In the **Label** text field, type Membrane.

Load the variables that define the theoretical response of an undamped membrane.

Variables 1

1 In the **Definitions** toolbar, click  **Local Variables**.

2 In the **Settings** window for **Variables**, locate the **Variables** section.

3 Click  **Load from File**.

4 Browse to the model's Application Libraries folder and double-click the file `condenser_microphone_variables.txt`.

Integration 1 (intop1)

1 In the **Definitions** toolbar, click  **Nonlocal Couplings** and choose **Integration**.

2 In the **Settings** window for **Integration**, type `intop_be` in the **Operator name** text field.

3 Locate the **Source Selection** section. From the **Geometric entity level** list, choose **Boundary**.

4 From the **Selection** list, choose **Membrane**.

ADD MATERIAL

1 In the **Materials** toolbar, click  **Add Material** to open the **Add Material** window.

2 Go to the **Add Material** window.

3 In the tree, select **Built-in > Air**.

4 Click the **Add to Component** button in the window toolbar.

5 In the **Materials** toolbar, click  **Add Material** to close the **Add Material** window.

Having set up the materials, proceed to setting up and defining the physics. Begin with the electric problem: Electrostatics and Circuit.

ELECTROSTATIC (ES)

Boundary Terminal 1

1 In the **Physics** toolbar, click  **Boundaries** and choose **Boundary Terminal**.

2 Select Boundaries 2, 4, 6, and 9 only.

3 In the **Settings** window for **Boundary Terminal**, locate the **Terminal** section.

4 From the **Terminal type** list, choose **Circuit**.

Ground 1

1 In the **Physics** toolbar, click  **Boundaries** and choose **Ground**.

2 Select Boundaries 3 and 12–14 only.

Now, set up the small external electrical circuit that is depicted in [Figure 1](#).

ELECTRICAL CIRCUIT (CIR)

External I vs. U I (IvsUI)

- 1 In the **Electrical Circuit** toolbar, click  **External I vs. U**.
- 2 In the **Settings** window for **External I vs. U**, locate the **Node Connections** section.
- 3 In the table, enter the following settings:

Label	Node names
p	1
n	0

- 4 Locate the **External Device** section. From the V list, choose **Terminal voltage (es/termI)**.

Resistor I (RI)

- 1 In the **Electrical Circuit** toolbar, click  **Resistor**.
- 2 In the **Settings** window for **Resistor**, locate the **Node Connections** section.
- 3 In the table, enter the following settings:

Label	Node names
p	1
n	2

- 4 Locate the **Device Parameters** section. In the R text field, type Rpreamp.

Voltage Source I - DC: Vpol

- 1 In the **Electrical Circuit** toolbar, click  **Voltage Source**.
- 2 In the **Settings** window for **Voltage Source**, type Voltage Source 1 - DC: Vpol in the **Label** text field.
- 3 Locate the **Node Connections** section. In the table, enter the following settings:

Label	Node names
p	2
n	0

4 Locate the **Device Parameters** section. In the v_{src} text field, type $Vp01$.

Next, add two additional circuit components that are only used to excite the membrane when analyzing the capacitance of the microphone. These will be disabled during the microphone response study.

Resistor 2 (R2)

1 In the **Electrical Circuit** toolbar, click  **Resistor**.

2 In the **Settings** window for **Resistor**, locate the **Node Connections** section.

3 In the table, enter the following settings:

Label	Node names
p	1
n	3

4 Locate the **Device Parameters** section. In the R text field, type $1e-3[\text{ohm}]$.

Voltage Source 2 - AC: $\text{linper}(1)$

1 In the **Electrical Circuit** toolbar, click  **Voltage Source**.

2 In the **Settings** window for **Voltage Source**, type Voltage Source 2 - AC: $\text{linper}(1)$ in the **Label** text field.

3 Locate the **Node Connections** section. In the table, enter the following settings:

Label	Node names
p	3
n	0

4 Locate the **Device Parameters** section. In the v_{src} text field, type $\text{linper}(1)$.

Next, set up the acoustics before turning to the membrane model and the Moving Mesh interface.

THERMOVISCOUS ACOUSTICS, FREQUENCY DOMAIN (TA)

Pressure (Adiabatic) 1

1 In the **Physics** toolbar, click  **Boundaries** and choose **Pressure (Adiabatic)**.

2 Select Boundary 8 only.

3 In the **Settings** window for **Pressure (Adiabatic)**, locate the **Pressure** section.

4 In the p_{bnd} text field, type $p0$.

MULTIPHYSICS

Thermoviscous Acoustic–Structure Boundary 1 (tsb1)

- 1 In the **Physics** toolbar, click  **Multiphysics Couplings** and choose **Boundary > Thermoviscous Acoustic–Structure Boundary**.
- 2 In the **Settings** window for **Thermoviscous Acoustic–Structure Boundary**, locate the **Boundary Selection** section.
- 3 From the **Selection** list, choose **Membrane**.

The last step couples the membrane to the thermoviscous acoustic domain. The multiphysics coupling feature sets the acoustic velocity equal to $i\omega$ times the deformation of the membrane (this is the time derivative in the frequency domain). This condition is a bidirectional constraint, meaning that a reaction force is added to the membrane equation, ensuring a bidirectional coupling.

Now, set up the membrane model, constrain it at the outer perimeter where it is fixed and add the forces that act on it. They are the electrostatic forces given by the Maxwell stress tensor and the incident pressure field p_{in} . Use the `linper()` operator to tell COMSOL that the incident pressure is only a harmonic frequency-dependent quantity (not a static load).

MEMBRANE (MBRN)

- 1 In the **Model Builder** window, under **Component 1 (comp1)** click **Membrane (mbrn)**.
- 2 In the **Settings** window for **Membrane**, locate the **Boundary Selection** section.
- 3 From the **Selection** list, choose **Membrane**.

Thickness and Offset 1

- 1 In the **Model Builder** window, under **Component 1 (comp1)** > **Membrane (mbrn)** click **Thickness and Offset 1**.
- 2 In the **Settings** window for **Thickness and Offset**, locate the **Thickness and Offset** section.
- 3 In the d_0 text field, type `tm`.

Linear Elastic Material 1

- 1 In the **Model Builder** window, click **Linear Elastic Material 1**.
- 2 In the **Settings** window for **Linear Elastic Material**, locate the **Linear Elastic Material** section.
- 3 From the E list, choose **User defined**. In the associated text field, type `Em`.
- 4 From the ν list, choose **User defined**. In the associated text field, type `num`.
- 5 From the ρ list, choose **User defined**. In the associated text field, type `rhom`.

Initial Stress and Strain 1

- 1 In the **Physics** toolbar, click  **Attributes** and choose **Initial Stress and Strain**.
- 2 In the **Settings** window for **Initial Stress and Strain**, locate the **Initial Stress and Strain** section.
- 3 Specify the N_0 matrix as

Tm0	0
0	Tm0

Fixed Constraint 1

- 1 In the **Physics** toolbar, click  **Points** and choose **Fixed Constraint**.
- 2 Select Point 12 only.

Face Load 1 - Incident Pressure

- 1 In the **Physics** toolbar, click  **Boundaries** and choose **Face Load**.
- 2 In the **Settings** window for **Face Load**, type Face Load 1 - Incident Pressure in the **Label** text field.
- 3 Locate the **Boundary Selection** section. From the **Selection** list, choose **Membrane**.
- 4 Locate the **Force** section. From the **Load type** list, choose **Pressure**.
- 5 In the p text field, type $\text{linper}(\text{pin})$.

COMPONENT 1 (COMP1)

Deforming Domain 1

- 1 In the **Physics** toolbar, click  **Moving Mesh** and choose **Free Deformation**.
- 2 In the **Settings** window for **Deforming Domain**, locate the **Domain Selection** section.
- 3 From the **Selection** list, choose **Manual**.
- 4 Select Domains 1 and 3 only.
- 5 Locate the **Smoothing** section. From the **Mesh smoothing type** list, choose **Laplace**.

The **Laplace** smoothing option is the cheapest option in terms of computations because it is linear and uses one equation for each coordinate direction, which are not coupled to each other. However, there is no mechanism in Laplace smoothing that prevents inversion of elements. Therefore, this method is most suitable for small deformations in a linear regime, as in this model.

Fixed Boundary 1

- 1 In the **Moving Mesh** toolbar, click  **Fixed Boundary**.

2 Select Boundaries 2, 11, and 14 only.

Symmetry/Roller 1

1 In the **Moving Mesh** toolbar, click  **Symmetry/Roller**.

2 Select Boundary 1 only.

The above **Moving Mesh** feature ensures that the computational mesh deforms according to the membrane deformation (um,wm). The deformation of the (adjacent) membrane is automatically used as the mesh movement on the boundary.

MULTIPHYSICS

Electromechanics, Boundary 1 (emfb1)

In the **Physics** toolbar, click  **Multiphysics Couplings** and choose **Boundary > Electromechanics, Boundary**.

MESH 1

Mapped 1

1 In the **Mesh** toolbar, click  **Mapped**.

2 In the **Settings** window for **Mapped**, locate the **Domain Selection** section.

3 From the **Geometric entity level** list, choose **Domain**.

4 Select Domains 1 and 3 only.

5 Click to expand the **Reduce Element Skewness** section. Select the **Adjust edge mesh** checkbox.

Distribution 1

1 Right-click **Mapped 1** and choose **Distribution**.

2 Select Boundary 3 only.

3 In the **Settings** window for **Distribution**, locate the **Distribution** section.

4 In the **Number of elements** text field, type 30.

Distribution 2

1 In the **Model Builder** window, right-click **Mapped 1** and choose **Distribution**.

2 Select Boundary 10 only.

3 In the **Settings** window for **Distribution**, locate the **Distribution** section.



4 From the **Distribution type** list, choose **Predefined**.

5 In the **Number of elements** text field, type 10.

6 In the **Element ratio** text field, type 2.

7 Select the **Symmetric distribution** checkbox.

Distribution 3

- 1 Right-click **Mapped 1** and choose **Distribution**.
- 2 Select Boundary 12 only.
- 3 In the **Settings** window for **Distribution**, locate the **Distribution** section.
- 4 In the **Number of elements** text field, type 4.
- 5 Click  **Build Selected**.
- 6 Click the  **Zoom Extents** button in the **Graphics** toolbar.

Free Triangular 1

In the **Mesh** toolbar, click  **Free Triangular**.

Size 1

- 1 Right-click **Free Triangular 1** and choose **Size**.
- 2 In the **Settings** window for **Size**, locate the **Element Size** section.
- 3 Click the **Custom** button.
- 4 Locate the **Element Size Parameters** section.
- 5 Select the **Maximum element size** checkbox. In the associated text field, type 0.1.
- 6 Select the **Resolution of narrow regions** checkbox. In the associated text field, type 2.
- 7 Click  **Build All**.

Boundary Layers 1

- 1 In the **Mesh** toolbar, click  **Boundary Layers**.
- 2 In the **Settings** window for **Boundary Layers**, click to expand the **Transition** section.
- 3 Clear the **Smooth transition to interior mesh** checkbox.

Boundary Layer Properties

- 1 In the **Model Builder** window, click **Boundary Layer Properties**.
- 2 Select Boundaries 4–7, 9, 10, 13, and 14 only.
- 3 In the **Settings** window for **Boundary Layer Properties**, locate the **Layers** section.
- 4 In the **Number of layers** text field, type 5.
- 5 From the **Thickness specification** list, choose **First layer**.
- 6 In the **Thickness** text field, type 2[um].

7 Click  **Build Selected**.

The mesh is built such that it resolves the acoustic boundary layer at the maximal frequency of 300 kHz. At this frequency the viscous boundary layer is about 4 μm thick, corresponding to roughly 1/5 of the air-gap thickness.

STUDY 1 - FREQUENCY RESPONSE

- 1 In the **Model Builder** window, click **Study 1**.
- 2 In the **Settings** window for **Study**, type Study 1 - Frequency Response in the **Label** text field.
- 3 Locate the **Study Settings** section. Clear the **Generate default plots** checkbox.

Step 1: Stationary

Notice that the **Include geometric nonlinearity** checkbox is selected but unavailable, as it is needed for the prestress study to work.



Notice the small orange warning sign next to Thermoviscous Acoustics and the Multiphysics coupling indicating that these are not solved in the stationary study step (as expected).

Now, disable the parts of the **Electrical Circuit** that are used to model the capacitance.

- 1 In the **Model Builder** window, under **Study 1 - Frequency Response** click **Step 1: Stationary**.
- 2 In the **Settings** window for **Stationary**, locate the **Physics and Variables Selection** section.
- 3 Select the **Modify model configuration for study step** checkbox.
- 4 In the tree, select **Component 1 (comp1) > Electrical Circuit (cir) > Resistor 2 (R2)** and **Component 1 (comp1) > Electrical Circuit (cir) > Voltage Source 2 - AC: linper(1) (V2)**.
- 5 Click  **Disable**.

Step 2: Frequency-Domain Perturbation

- 1 In the **Model Builder** window, click **Step 2: Frequency-Domain Perturbation**.
- 2 In the **Settings** window for **Frequency-Domain Perturbation**, locate the **Study Settings** section.
- 3 From the **Frequency unit** list, choose **kHz**.

- 4 In the **Frequencies** text field, type $\{0.1 \text{ range}(2.5, 2.5, 300)\}$.
This gives a frequency range of 100 Hz - 300 kHz. The reason for including such high frequencies is to be able to observe the fall-off in sensitivity.
Note that you also need to solve for the **Moving Mesh** in the frequency domain perturbation step. It ensures the coupling between the membrane movement and the electrostatic physics. The mesh movement solved for in the perturbation step represents a linear (small signal) effect on top of the initial DC deformation.
Now, disable the parts of the **Electrical Circuit** that are used to model the capacitance.
- 5 Locate the **Physics and Variables Selection** section. Select the **Modify model configuration for study step** checkbox.
- 6 In the tree, select **Component 1 (comp1) > Electrical Circuit (cir) > Resistor 2 (R2)** and **Component 1 (comp1) > Electrical Circuit (cir) > Voltage Source 2 - AC: linper(1) (V2)**.
- 7 Click  **Disable**.
- 8 In the **Study** toolbar, click  **Compute**.

RESULTS

Global Evaluation 1

- 1 In the **Model Builder** window, expand the **Results** node.
- 2 Right-click **Results > Derived Values** and choose **Global Evaluation**.
- 3 In the **Settings** window for **Global Evaluation**, locate the **Data** section.
- 4 From the **Parameter selection (freq)** list, choose **First**.
- 5 Locate the **Expressions** section. In the table, enter the following settings:

Expression	Unit	Description
es.V0_1	V	Terminal voltage
es.Q0_1	C	Terminal charge

- 6 From the **Expression evaluated for** list, choose **Static solution**.
- 7 Click  **Evaluate**.

TABLE I



- 1 Go to the **Table I** window.

The static polarization voltage across the membrane should equal 100.0 V (as defined).
The resulting static membrane charge is 6.26×10^{-10} C.

Set default units for result presentation, for the displacement and the velocity.

RESULTS

Preferred Units I

- 1 In the **Results** toolbar, click  **Configurations** and choose **Preferred Units**.
- 2 In the **Settings** window for **Preferred Units**, locate the **Units** section.
- 3 Click  **Add Physical Quantity**.
- 4 In the **Physical Quantity** dialog, select **General > Displacement (m)** in the tree.
- 5 Click **OK**.
- 6 In the **Settings** window for **Preferred Units**, locate the **Units** section.
- 7 In the table, enter the following settings:



Quantity	Unit	Preferred unit
Displacement	m	μm

- 8 Click  **Add Physical Quantity**.
- 9 In the **Physical Quantity** dialog, select **General > Velocity (m/s)** in the tree.
- 10 Click **OK**.
- 11 In the **Settings** window for **Preferred Units**, locate the **Units** section.
- 12 In the table, enter the following settings:

Quantity	Unit	Preferred unit
Velocity	m/s	mm/s

- 13 Click  **Apply**.

RESULT TEMPLATES

- 1 In the **Results** toolbar, click  **Result Templates** to open the **Result Templates** window.
- 2 Go to the **Result Templates** window.
- 3 In the tree, select **Study 1 - Frequency Response/Solution 1 (sol1) > Thermoviscous Acoustics, Frequency Domain > Acoustic Velocity (ta)**.
- 4 Click the **Add Result Template** button in the window toolbar.
- 5 In the **Results** toolbar, click  **Result Templates** to close the **Result Templates** window.

RESULTS

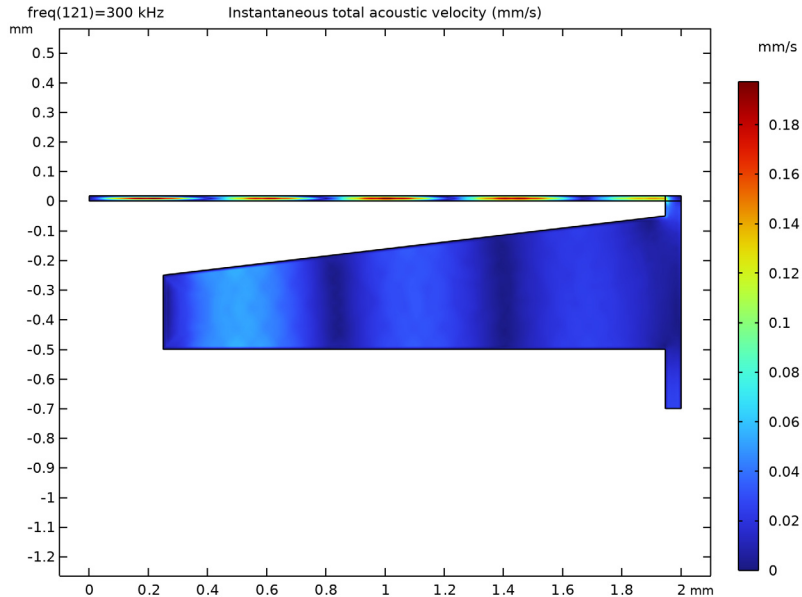

Acoustic Velocity (ta)

The plot should look like this.



In the same way, you can also add a plot from the **Result Templates** for the acoustic pressure or the temperature variation.

RESULT TEMPLATES

- 1 In the **Results** toolbar, click  **Result Templates** to open the **Result Templates** window.
- 2 Go to the **Result Templates** window.
- 3 In the tree, select **Study 1 - Frequency Response/Solution 1 (sol1) > Electrostatics > Electric Potential (es)**.
- 4 Click the **Add Result Template** button in the window toolbar.
- 5 In the **Results** toolbar, click  **Result Templates** to close the **Result Templates** window.

RESULTS

Electric Potential (es)

- 1 In the **Settings** window for **2D Plot Group**, locate the **Color Legend** section.
- 2 Select the **Show units** checkbox.

3 Clear the **Show maximum and minimum values** checkbox.

The plot should look like this.

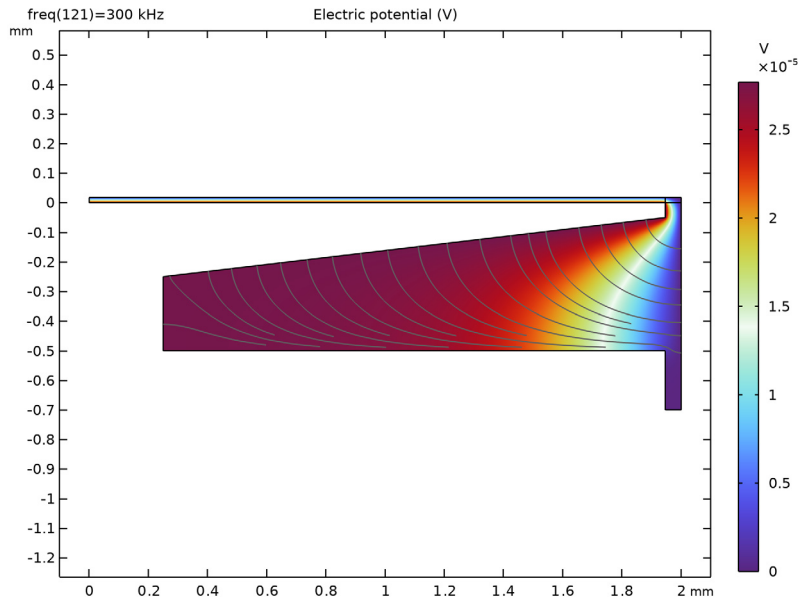

Sensitivity and Phase

- 1 In the **Results** toolbar, click  **ID Plot Group**.
- 2 In the **Settings** window for **ID Plot Group**, type **Sensitivity** and **Phase** in the **Label** text field.
- 3 Click to expand the **Title** section. From the **Title type** list, choose **Label**.
- 4 Locate the **Plot Settings** section.
- 5 Select the **y-axis label** checkbox. In the associated text field, type **Sensitivity (dB rel. 1 V/Pa)**.
- 6 Locate the **Legend** section. From the **Position** list, choose **Lower left**.

Octave Band 1

- 1 In the **Sensitivity and Phase** toolbar, click  **More Plots** and choose **Octave Band**.
- 2 In the **Settings** window for **Octave Band**, locate the **Selection** section.
- 3 From the **Geometric entity level** list, choose **Global**.
- 4 Locate the **y-Axis Data** section. In the **Expression** text field, type **es.V0_1**.

- 5 In the **Amplitude reference** text field, type $\text{pin}/\text{sqrt}(2)$.
Notice that the amplitude reference is an RMS value.
- 6 Locate the **Plot** section. From the **Quantity** list, choose **Continuous power spectral density**.
- 7 Click to expand the **Legends** section. Select the **Show legends** checkbox.
- 8 From the **Legends** list, choose **Manual**.
- 9 In the table, enter the following settings:

Legends
Sensitivity

Graph Marker 1

- 1 Right-click **Octave Band 1** and choose **Graph Marker**.
- 2 In the **Settings** window for **Graph Marker**, locate the **Display** section.
- 3 From the **Display mode** list, choose **Line intersection**.
- 4 In the **x-coordinates** text field, type 1000, 10000.
- 5 Select the **Show lines** checkbox.
- 6 Locate the **Text Format** section. In the **Precision** text field, type 3.
- 7 Select the **Include unit** checkbox.

Sensitivity and Phase

In the **Sensitivity and Phase** toolbar, click  **Global**.

Global 1

- 1 In the **Settings** window for **Global**, locate the **y-Axis Data** section.
- 2 In the table, enter the following settings:

Expression	Unit	Description
$\text{arg}(\text{es.V0}_1)+\text{pi}$	rad	Phase

- 3 Select the **Unwrap phase** checkbox.
- 4 Locate the **x-Axis Data** section. From the **Unit** list, choose **Hz**.

Sensitivity and Phase

- 1 In the **Model Builder** window, click **Sensitivity and Phase**.
- 2 In the **Settings** window for **ID Plot Group**, locate the **Plot Settings** section.
- 3 Select the **Two y-axes** checkbox.

4 In the table, select the **Plot on secondary y-axis** checkbox for **Global 1**.

5 In the **Sensitivity and Phase** toolbar, click  **Plot**.

The microphone sensitivity and the phase curves should look like [Figure 2](#).

Now, plot the membrane deformation in a 1D plot, both the static and the harmonic components, as function of the radial coordinate.

Membrane Deformation

1 In the **Results** toolbar, click  **ID Plot Group**.

2 In the **Settings** window for **ID Plot Group**, type Membrane Deformation in the **Label** text field.

3 Locate the **Title** section. From the **Title type** list, choose **Label**.

Line Graph 1

1 Right-click **Membrane Deformation** and choose **Line Graph**.

2 In the **Settings** window for **Line Graph**, locate the **Selection** section.

3 From the **Selection** list, choose **Membrane**.

4 Locate the **y-Axis Data** section. In the **Expression** text field, type w_m .

5 Locate the **x-Axis Data** section. From the **Parameter** list, choose **Expression**.

6 In the **Expression** text field, type r .

7 In the **Membrane Deformation** toolbar, click  **Plot**.

The plot should look like this.

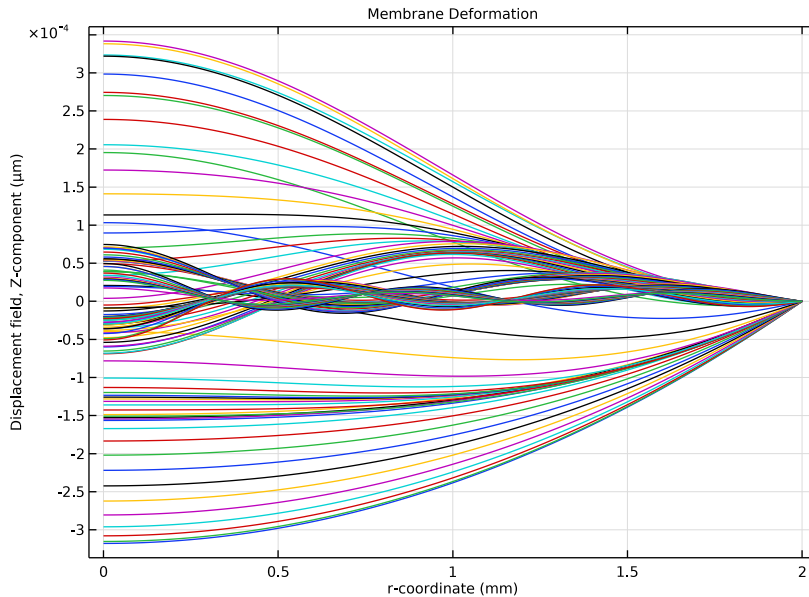

Static Membrane Deformation

- 1 In the **Model Builder** window, right-click **Membrane Deformation** and choose **Duplicate**.
- 2 In the **Settings** window for **ID Plot Group**, type **Static Membrane Deformation** in the **Label** text field.
- 3 Locate the **Data** section. From the **Parameter selection (freq)** list, choose **Last**.

Line Graph 1

- 1 In the **Model Builder** window, expand the **Static Membrane Deformation** node, then click **Line Graph 1**.
- 2 In the **Settings** window for **Line Graph**, locate the **y-Axis Data** section.
- 3 From the **Expression evaluated for** list, choose **Static solution**.

4 In the **Static Membrane Deformation** toolbar, click  **Plot**.

The plot should look like this.

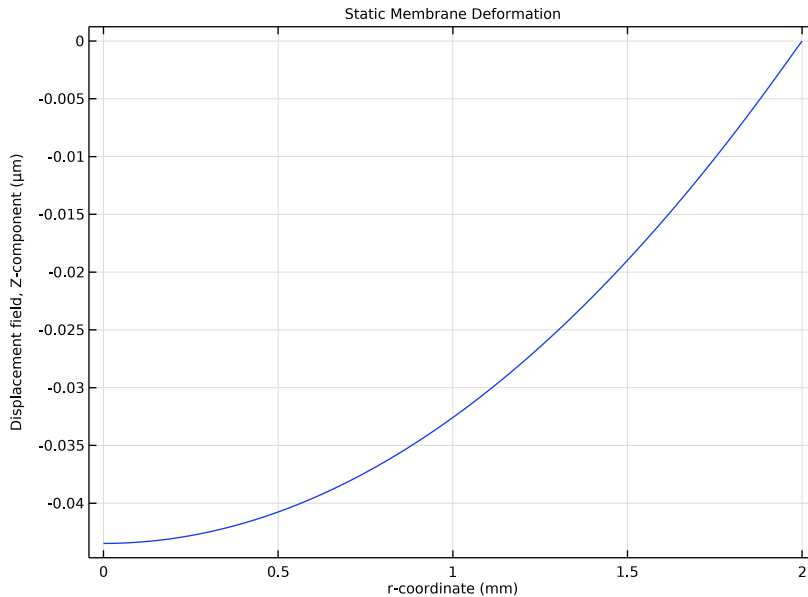

Average Membrane Velocity

1 In the **Results** toolbar, click  **ID Plot Group**.

2 In the **Settings** window for **ID Plot Group**, type Average Membrane Velocity in the **Label** text field.

3 Locate the **Title** section. From the **Title type** list, choose **Label**.

4 Locate the **Plot Settings** section.

5 Select the **y-axis label** checkbox. In the associated text field, type $|\mu\text{m}/\text{s}|$ (mm/s).

6 Locate the **Legend** section. From the **Position** list, choose **Upper left**.

Global 1

1 Right-click **Average Membrane Velocity** and choose **Global**.

2 In the **Settings** window for **Global**, locate the **y-Axis Data** section.

3 In the table, enter the following settings:

Expression	Unit	Description
abs(um_av)	mm/s	Model
abs(uth_av)	mm/s	Analytical approximation

4 In the **Average Membrane Velocity** toolbar, click  **Plot**.

5 Click the  **x-Axis Log Scale** button in the **Graphics** toolbar.

6 Click the  **y-Axis Log Scale** button in the **Graphics** toolbar.

The plot should look like this.

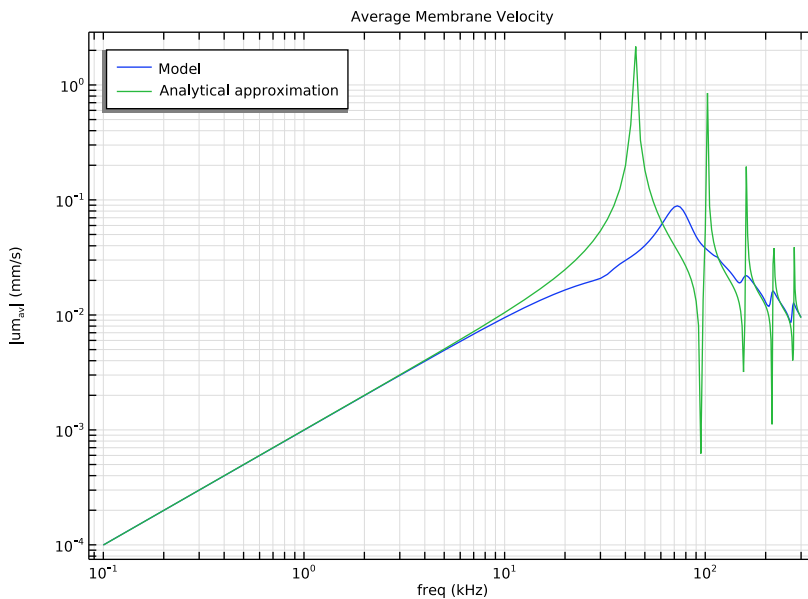

Average Membrane Deformation

1 In the **Results** toolbar, click  **ID Plot Group**.

2 In the **Settings** window for **ID Plot Group**, type Average Membrane Deformation in the **Label** text field.

3 Locate the **Title** section. From the **Title type** list, choose **Label**.

4 Locate the **Plot Settings** section.



5 Select the **y-axis label** checkbox. In the associated text field, type $|U_{av}|$ (μm).

- 6 Locate the **Legend** section. From the **Position** list, choose **Upper left**.

Global 1

- 1 Right-click **Average Membrane Deformation** and choose **Global**.
- 2 In the **Settings** window for **Global**, locate the **y-Axis Data** section.
- 3 In the table, enter the following settings:

Expression	Unit	Description
abs(U_av)	μm	Model
abs(Uth_av)	μm	Analytical approximation

- 4 In the **Average Membrane Deformation** toolbar, click  **Plot**.
- 5 Click the  **x-Axis Log Scale** button in the **Graphics** toolbar.
- 6 Click the  **y-Axis Log Scale** button in the **Graphics** toolbar.

The microphone sensitivity curve should look like [Figure 3](#).

Finally, plot the membrane deformation and pressure distribution using a 3D revolved geometry using a 2D revolution dataset, to reproduce [Figure 4](#).

Revolution 2D 1

- 1 In the **Results** toolbar, click  **More Datasets** and choose **Revolution 2D**.
- 2 In the **Settings** window for **Revolution 2D**, click to expand the **Revolution Layers** section.
- 3 In the **Start angle** text field, type -90.
- 4 In the **Revolution angle** text field, type 290.

Selection

In the **Results** toolbar, click  **Attributes** and choose **Selection**.

Membrane Deformation and Pressure

- 1 In the **Results** toolbar, click  **3D Plot Group**.
- 2 In the **Settings** window for **3D Plot Group**, type Membrane Deformation and Pressure in the **Label** text field.
- 3 Click to expand the **Title** section. From the **Title type** list, choose **Label**.
- 4 Locate the **Color Legend** section. Select the **Show units** checkbox.

Surface 1

- 1 Right-click **Membrane Deformation and Pressure** and choose **Surface**.

- 2 In the **Settings** window for **Surface**, click **Replace Expression** in the upper-right corner of the **Expression** section. From the menu, choose **Component 1 (comp1) > Membrane > Displacement > mbrn.disp - Displacement magnitude - m**.
- 3 Locate the **Coloring and Style** section. From the **Color table** list, choose **SpectrumLight**.

Deformation 1

- 1 Right-click **Surface 1** and choose **Deformation**.
- 2 In the **Settings** window for **Deformation**, click **Replace Expression** in the upper-right corner of the **Expression** section. From the menu, choose **Component 1 (comp1) > Membrane > Displacement > um,vm,wm - Displacement field**.

Transformation 1

- 1 In the **Model Builder** window, right-click **Surface 1** and choose **Transformation**.
- 2 In the **Settings** window for **Transformation**, locate the **Transformation** section.
- 3 In the **z** text field, type 0.1 [mm].
- 4 Clear the **Apply to dataset edges** checkbox.

Surface 2

- 1 In the **Model Builder** window, right-click **Membrane Deformation and Pressure** and choose **Surface**.
- 2 In the **Settings** window for **Surface**, locate the **Expression** section.
- 3 In the **Expression** text field, type $ta.p_t$.
- 4 Locate the **Coloring and Style** section. From the **Color table** list, choose **Wave**.
- 5 From the **Scale** list, choose **Linear symmetric**.
- 6 In the **Membrane Deformation and Pressure** toolbar, click  **Plot**.

The 3D plot should look like [Figure 4](#).

As a final analysis set up a study for computing the capacitance of the microphone.

ADD STUDY

- 1 In the **Home** toolbar, click  **Add Study** to open the **Add Study** window.
- 2 Go to the **Add Study** window.
- 3 Find the **Physics interfaces in study** subsection. In the table, clear the **Solve** checkbox for **Thermoviscous Acoustics, Frequency Domain (ta)**.
- 4 Find the **Multiphysics couplings in study** subsection. In the table, clear the **Solve** checkbox for **Thermoviscous Acoustic–Structure Boundary 1 (tsb1)**.
- 5 Find the **Studies** subsection. In the **Select Study** tree, select **General Studies > Stationary**.

- 6 Click the **Add Study** button in the window toolbar.
- 7 In the **Home** toolbar, click  **Add Study** to close the **Add Study** window.



STUDY 2 - CAPACITANCE

- 1 In the **Settings** window for **Study**, type Study 2 - Capacitance in the **Label** text field.
- 2 Locate the **Study Settings** section. Clear the **Generate default plots** checkbox.

Step 1: Stationary

- 1 In the **Model Builder** window, under **Study 2 - Capacitance** click **Step 1: Stationary**.
- 2 In the **Settings** window for **Stationary**, locate the **Physics and Variables Selection** section.
- 3 Select the **Modify model configuration for study step** checkbox.
- 4 In the tree, select **Component 1 (comp1) > Electrical Circuit (cir) > Resistor 2 (R2)** and **Component 1 (comp1) > Electrical Circuit (cir) > Voltage Source 2 - AC: linper(1) (V2)**.
- 5 Click  **Disable**.

Step 2: Frequency-Domain Perturbation

- 1 In the **Study** toolbar, click  **More Study Steps** and choose **Frequency Domain > Frequency-Domain Perturbation**.
- 2 In the **Settings** window for **Frequency-Domain Perturbation**, locate the **Study Settings** section.
- 3 From the **Frequency unit** list, choose **kHz**.
- 4 In the **Frequencies** text field, type $\{0.1 \text{ range}(2.5, 2.5, 300)\}$.
Disable the incident pressure load on the membrane. For the capacitance analysis the membrane is driven by a voltage source.
- 5 Locate the **Physics and Variables Selection** section. Select the **Modify model configuration for study step** checkbox.
- 6 In the tree, select **Component 1 (comp1) > Membrane (mbrn), Controls spatial frame > Face Load 1 - Incident Pressure**.
- 7 Click  **Disable**.
- 8 In the **Study** toolbar, click  **Compute**.

RESULTS

Microphone Capacitance

- 1 In the **Results** toolbar, click  **ID Plot Group**.

- 2 In the **Settings** window for **ID Plot Group**, type **Microphone Capacitance** in the **Label** text field.
- 3 Locate the **Title** section. From the **Title type** list, choose **Label**.
- 4 Locate the **Plot Settings** section.
- 5 Select the **y-axis label** checkbox. In the associated text field, type **Capacitance (pF)**.
- 6 Locate the **Axis** section. Select the **x-axis log scale** checkbox.

Global 1

- 1 Right-click **Microphone Capacitance** and choose **Global**.
- 2 In the **Settings** window for **Global**, locate the **Data** section.
- 3 From the **Dataset** list, choose **Study 2 - Capacitance/Solution 3 (sol3)**.
- 4 Locate the **y-Axis Data** section. In the table, enter the following settings:

Expression	Unit	Description
<code>abs(es.Q0_1/es.V0_1)</code>	pF	Frequency
<code>withsol('sol14',abs(es.Q0_1/es.V0_1))</code>	pF	Stationary

- 5 In the **Microphone Capacitance** toolbar, click  **Plot**.

