



Model created in COMSOL Multiphysics 6.4

# Acoustic Cloaking

## Introduction

---

Recent studies (see [Ref. 1](#)) have shown the feasibility of manufacturing “invisibility cloaks” using layered metamaterials. Draping an object in a cloak makes it transparent, or nearly transparent, to electromagnetic waves.

The same principle can be used in acoustics to hide an object from acoustic radiation. This example looks at sound scattering from a plane wave incident on a hard-walled cylinder. Results with the cylinder clad in a homogenized cloak and a layered cloak (described in [Ref. 2](#)) are compared to a solution without the cloak.

## Model Definition

---

A cylinder with a 1 m radius is surrounded by a metamaterial cloak consisting of a fluid with anisotropic density and scalar bulk modulus. Such a fluid can be modeled with the built-in **Anisotropic Acoustics** material model.

A way to set up an approximation to such a model is to use layers of two alternating fluids. In this tutorial, we use a 50 layer model with a layer thickness of 2 cm and a 20 layer model with a layer thickness of 5 cm. The material properties are similar to those in [Ref. 2](#) and defined as follows:

$$\begin{aligned}\rho_1 &= \frac{r + \sqrt{2rR_1 - R_1^2}}{r - R_1} \rho_b \\ c_1 &= \frac{R_2 - R_1}{R_2} \frac{r}{r - R_1} c_b \\ \rho_2 &= \rho_b^2 / \rho_1 \\ c_2 &= c_1\end{aligned}$$

In this formula:

- $\rho_1$ ,  $\rho_2$ ,  $c_1$ , and  $c_2$  are the density and speed of sound of materials 1 and 2;
- $\rho_b = 1.25 \text{ kg/m}^3$  and  $c_b = 343 \text{ m/s}$ , are the density and speed of sound in the outside medium, which is air;
- $R_1$  and  $R_2$  are the inner and outer radius of the cloak; and
- $r$  is the distance to the cylinder axis.

The material data for the corresponding anisotropic material can be calculated in the homogenization limit: for the effective bulk modulus and the effective density in the

tangential direction (along the layers) as the volume average of their reciprocals; and for the effective density in the normal direction (perpendicular to the layers) as the volume average.

$$K = \frac{2K_1K_2}{K_1 + K_2}$$

$$\rho_t = \frac{2\rho_1\rho_2}{\rho_1 + \rho_2}$$

$$\rho_n = \frac{\rho_1 + \rho_2}{2}$$

The model considers a frequency of  $f = 300$  Hz and solves the Helmholtz equation for the total acoustic pressure:

$$\nabla \cdot (-\rho^{-1} \nabla p_t) - \frac{\omega^2 p_t}{K} = 0$$

Here,  $\rho^{-1}$  is a tensor for the anisotropic material, the bulk modulus  $K = \rho c^2$  for the isotropic material, and  $p_t$  is the total acoustic pressure. To describe an incident plane wave traveling in the  $x$  direction, a background field  $p_b$  is defined as  $e^{-ik_b x}$ , where  $k_b = 2\pi f/c_b$  is the propagation constant in the background medium. The equation is solved for the scattered field  $p_s$ , using the definition

$$p_t \equiv p_b + p_s$$

The geometric mirror symmetry of the problem is used to reduce the modeling domain to half of the full geometry (see [Figure 1](#)). The background medium is truncated with a cylindrical radiation condition (see the *Acoustics Module User's Guide* for details about the theory) on its outer boundaries.

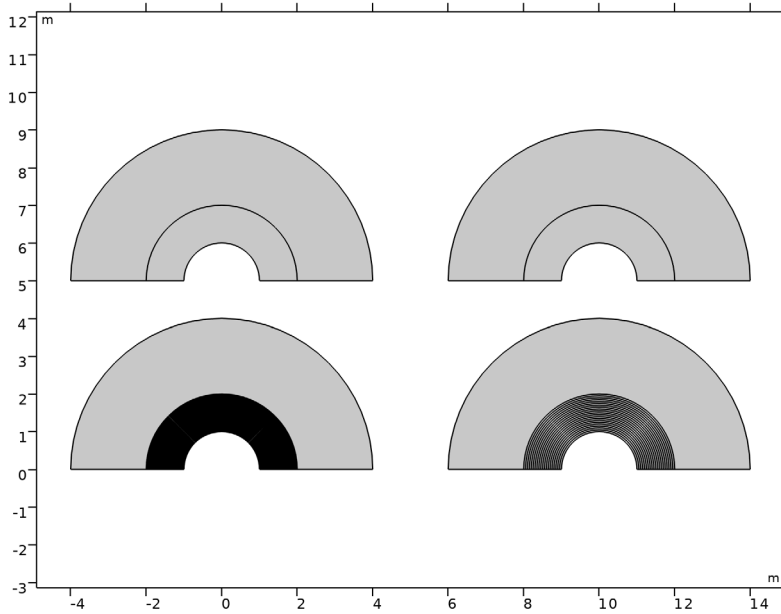

*Figure 1: The geometries used in the tutorial: homogenized cloak (upper left), no cloak (upper right), 50 layer cloak (lower left), and 20 layer cloak (lower right). The center cylinder cut out from the geometry is covered by the cloak and outside the cloak the background material is truncated at a 4 m distance from the center. The layers in the 50 layer cloak geometry are too thin to see clearly in this image.*

### *Results and Discussion*

The total acoustic pressure for the four different cases can be seen in [Figure 2](#). The top right figure shows the pressure field without the cloak, when the cylinder is surrounded only by air. The incident pressure wave is scattered in all directions and is significantly influenced by the cylinder. In the upper-left figure, we see the homogenized cloak in use. The incident wave is undisturbed outside the cloak and it is not possible to determine that there is a cylinder present at all. The two bottom figures show how the cloak gets better when the number of layers is increased and the model is more similar to the homogenized cloak.

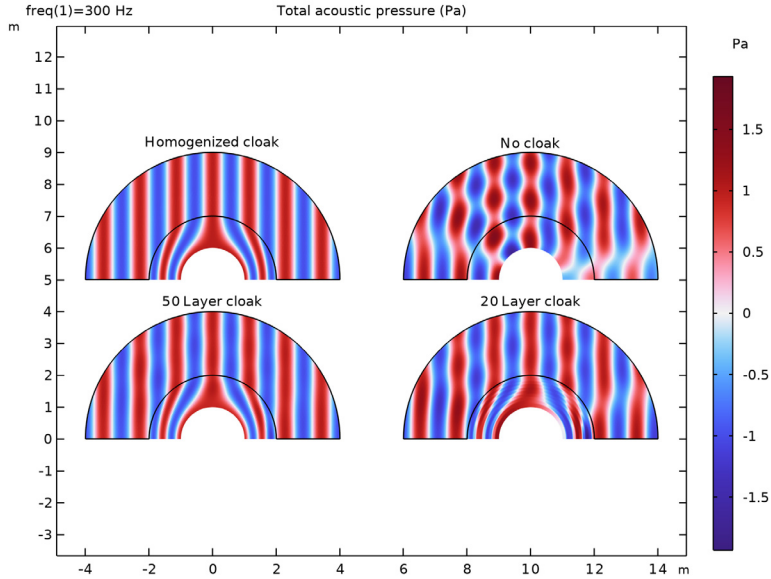
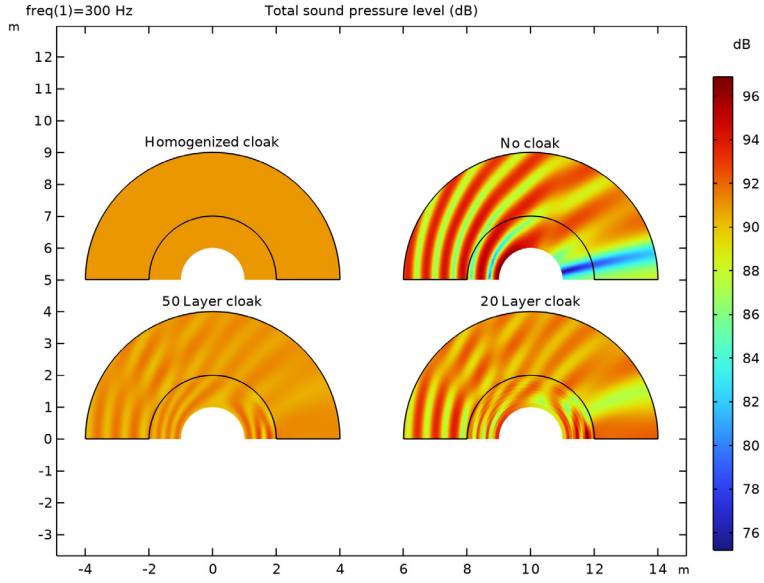

Figure 2: Total acoustic pressure for the four studied cases: homogenized cloak (upper left), no cloak (upper right), 50 layer cloak (lower left), and 20 layer cloak (lower right).

Figure 3 shows the total sound pressure level for the same cases. When no cloak is used, the shadow zone behind the cylinder is easily visible as well as the pressure peaks on the side where the wave is incident. With the homogenized cloak, the pressure variations are not visible.



*Figure 3: Total sound pressure level for the four studied cases: homogenized cloak (upper left), no cloak (upper right), 50 layer cloak (lower left), and 20 layer cloak (lower right).*

Looking only at the scattered sound pressure level (Figure 4) we can see a significant difference in the scattered field for the four cases. The scattered sound pressure level decreases as the cloak tends toward the homogenized cloak.

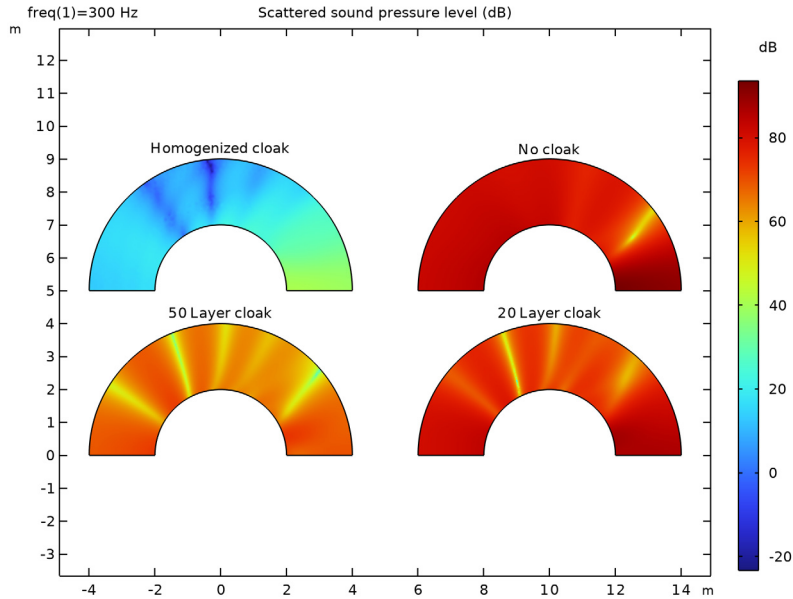

Figure 4: Scattered sound pressure level for the four studied cases: homogenized cloak (upper left), no cloak (upper right), 50 layer cloak (lower left), and 20 layer cloak (lower right).

Another way to illustrate the effect of the cloak is to look at the total acoustic pressure along the cloak boundary. This is shown in Figure 5, where we can see that the background pressure field curve coincides with the curve for the homogenized cloak as expected for an effective cloak.

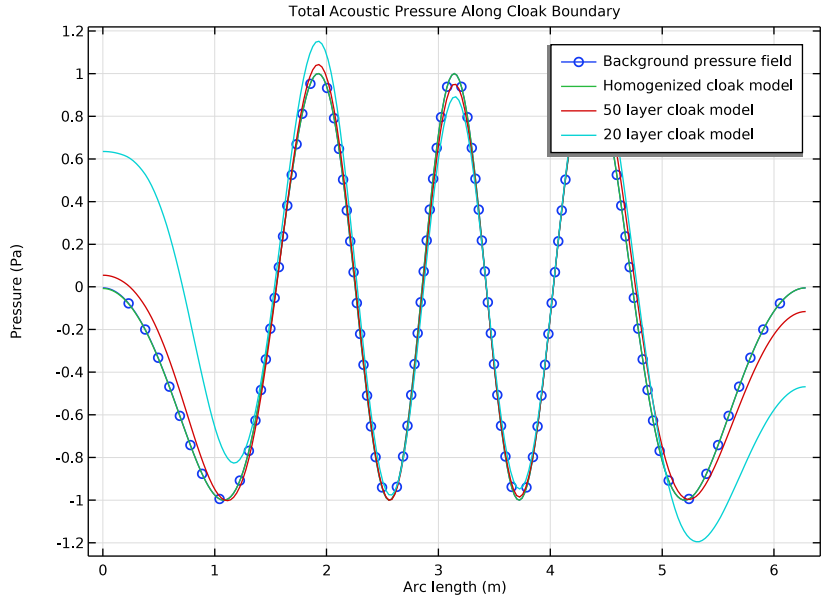

Figure 5: Pressure at the acoustic cloak boundary.

Finally, in Figure 6, the speed of sound in the principal directions of the homogenized anisotropic material is shown.

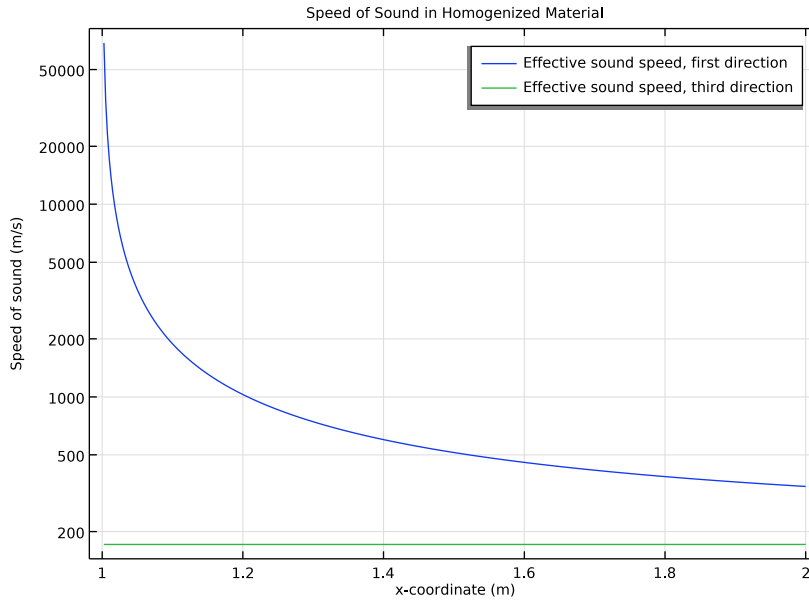

Figure 6: Speed of sound across the acoustic cloak.

The instructions and results that follow, deal only with a frequency of 300 Hz, but you can modify the model and use a different frequency, or sweep over a range of frequencies, to see how this affects the cloaking.

## References

1. Several COMSOL Conference papers:

[www.comsol.com/paper/analyzing-the-performance-of-lined-and-unlined-simplified-cylindrical-cloaks-5478](http://www.comsol.com/paper/analyzing-the-performance-of-lined-and-unlined-simplified-cylindrical-cloaks-5478)

[www.comsol.com/paper/designing-silver-nanowires-invisible-cloak-based-on-effective-medium-approach-9831](http://www.comsol.com/paper/designing-silver-nanowires-invisible-cloak-based-on-effective-medium-approach-9831)

[www.comsol.com/paper/electromagnetic-analysis-of-cloaking-metamaterial-structures-5463](http://www.comsol.com/paper/electromagnetic-analysis-of-cloaking-metamaterial-structures-5463)

2. D. Torrent and J. Sánchez-Dehesa, “Acoustic Cloaking in Two Dimensions: a Feasible Approach,” *New J. Phys.*, vol. 10, 063015, 2008.

---

**Application Library path:** Acoustics\_Module/Tutorials,\_Pressure\_Acoustics/  
acoustic\_cloaking

---

### *Modeling Instructions*



---

From the **File** menu, choose **New**.

#### **NEW**



In the **New** window, click  **Model Wizard**.

#### **MODEL WIZARD**

- 1 In the **Model Wizard** window, click  **2D**.
- 2 In the **Select Physics** tree, select **Acoustics** > **Pressure Acoustics** > **Pressure Acoustics, Frequency Domain (acpr)**.
- 3 Click **Add**.
- 4 Click  **Study**.
- 5 In the **Select Study** tree, select **General Studies** > **Frequency Domain**.
- 6 Click  **Done**.

#### **GEOMETRY I**

The geometry of this model is simple but a bit repetitive to create, due to the large number of circles involved. You will therefore import a geometry sequence from a file. The instructions for building the geometry can be found in the appendix at the end of this document.

- 1 In the **Geometry** toolbar, click **Insert Sequence** and choose **Insert Sequence**.
- 2 Browse to the model's Application Libraries folder and double-click the file `acoustic_cloaking_geom_sequence.mph`.
- 3 In the **Geometry** toolbar, click  **Build All**.
- 4 Click the  **Zoom Extents** button in the **Graphics** toolbar.

The geometry should look like that in [Figure 1](#).

The file you have just imported contains a few parameters that are used to generate the geometry. Now proceed to add some additional parameters that will be used in the analysis.

## GLOBAL DEFINITIONS

### Parameters 1

- 1 In the **Model Builder** window, under **Global Definitions** click **Parameters 1**.
- 2 In the **Settings** window for **Parameters**, locate the **Parameters** section.
- 3 In the table, enter the following settings:

Name	Expression	Value	Description
rhob	1.25[kg/m^3]	1.25 kg/m <sup>3</sup>	Density, background material
cb	343[m/s]	343 m/s	Speed of sound, background material
f0	300[Hz]	300 Hz	Frequency of the analysis
lam0	cb/f0	1.1433 m	Wavelength

The material properties in the cloaking involve dependencies on the inner and outer radius, the local distance from the center, and the properties of the surrounding background fluid. It is convenient to define these expressions as variables.

## DEFINITIONS

### Cylindrical System 2 (sys2)

- 1 In the **Definitions** toolbar, click  **Coordinate Systems** and choose **Cylindrical System**.
- 2 In the **Settings** window for **Cylindrical System**, locate the **Settings** section.
- 3 Find the **Origin** subsection. In the table, enter the following settings:

x (m)	y (m)
x1	y1

### Radial Coordinate: Homogenized Cloak

- 1 In the **Model Builder** window, right-click **Definitions** and choose **Variables**.
- 2 In the **Settings** window for **Variables**, type Radial Coordinate: Homogenized Cloak in the **Label** text field.
- 3 Locate the **Geometric Entity Selection** section. From the **Geometric entity level** list, choose **Domain**.
- 4 From the **Selection** list, choose **Selection: Homogenized Cloak**.

5 Locate the **Variables** section. In the table, enter the following settings:

Name	Expression	Unit	Description
r	sys2.r	m	Radial coordinate

*Radial Coordinate: 50 Layer Cloak*

- 1 Right-click **Definitions** and choose **Variables**.
- 2 In the **Settings** window for **Variables**, type Radial Coordinate: 50 Layer Cloak in the **Label** text field.
- 3 Locate the **Geometric Entity Selection** section. From the **Geometric entity level** list, choose **Domain**.
- 4 From the **Selection** list, choose **Selection: 50 Layer Cloak**.
- 5 Locate the **Variables** section. In the table, enter the following settings:

Name	Expression	Unit	Description
r	$\sqrt{(x-x3)^2+(y-y3)^2}$	m	Radial coordinate

*Radial Coordinate: 20 Layer Cloak*

- 1 Right-click **Definitions** and choose **Variables**.
- 2 In the **Settings** window for **Variables**, type Radial Coordinate: 20 Layer Cloak in the **Label** text field.
- 3 Locate the **Geometric Entity Selection** section. From the **Geometric entity level** list, choose **Domain**.
- 4 From the **Selection** list, choose **Selection: 20 Layer Cloak**.
- 5 Locate the **Variables** section. In the table, enter the following settings:

Name	Expression	Unit	Description
r	$\sqrt{(x-x4)^2+(y-y4)^2}$	m	Radial coordinate

*Variables: Acoustic Cloak Data*

- 1 In the **Definitions** toolbar, click **a= Local Variables**.
- 2 In the **Settings** window for **Variables**, type Variables: Acoustic Cloak Data in the **Label** text field.
- 3 Locate the **Geometric Entity Selection** section. From the **Geometric entity level** list, choose **Domain**.
- 4 From the **Selection** list, choose **Selection: Acoustic Cloak**.

5 Locate the **Variables** section. In the table, enter the following settings:

Name	Expression	Unit	Description
rho1	$\text{rhob} * (\text{r} + \sqrt{2 * \text{r} * \text{R1} - \text{R1}^2}) / (\text{r} - \text{R1})$	kg/m <sup>3</sup>	Density, Material 1
c1	$\text{cb} * (\text{R2} - \text{R1}) / \text{R2} * \text{r} / (\text{r} - \text{R1})$	m/s	Speed of sound, Material 1
rho2	$\text{rhob}^2 / \text{rho1}$	kg/m <sup>3</sup>	Density, Material 2
c2	c1	m/s	Speed of sound, Material 2
K1	$\text{rho1} * \text{c1}^2$	Pa	Bulk modulus, Material 1
K2	$\text{rho2} * \text{c2}^2$	Pa	Bulk modulus, Material 2
K	$2 * \text{K1} * \text{K2} / (\text{K1} + \text{K2})$	Pa	Effective bulk modulus
rho_tangential	$2 * \text{rho1} * \text{rho2} / (\text{rho1} + \text{rho2})$	kg/m <sup>3</sup>	Density along layers
rho_normal	$(\text{rho1} + \text{rho2}) / 2$	kg/m <sup>3</sup>	Density perpendicular to the layers

Now, proceed to add the materials. Material 1 and Material 2 are the two materials with varying properties that will be used in the layers to create an acoustic cloak. The homogenized material is an anisotropic material which properties also vary with thickness and are equivalent to a model with a large number of layers.

## MATERIALS

*Air*

- 1 In the **Model Builder** window, under **Component 1 (comp1)** right-click **Materials** and choose **Blank Material**.
- 2 In the **Settings** window for **Material**, type Air in the **Label** text field.
- 3 Locate the **Material Contents** section. In the table, enter the following settings:

Property	Variable	Value	Unit	Property group
Density	rho	rhob	kg/m <sup>3</sup>	Basic
Speed of sound	c	cb	m/s	Basic

*Material 1*

- 1 Right-click **Materials** and choose **Blank Material**.

- 2 In the **Settings** window for **Material**, type Material 1 in the **Label** text field.
- 3 Locate the **Geometric Entity Selection** section. From the **Selection** list, choose **Selection: Material 1**.
- 4 Locate the **Material Contents** section. In the table, enter the following settings:

Property	Variable	Value	Unit	Property group
Density	rho	rho1	kg/m <sup>3</sup>	Basic
Speed of sound	c	c1	m/s	Basic

#### *Material 2*

- 1 Right-click **Materials** and choose **Blank Material**.
- 2 In the **Settings** window for **Material**, type Material 2 in the **Label** text field.
- 3 Locate the **Geometric Entity Selection** section. From the **Selection** list, choose **Selection: Material 2**.
- 4 Locate the **Material Contents** section. In the table, enter the following settings:

Property	Variable	Value	Unit	Property group
Density	rho	rho2	kg/m <sup>3</sup>	Basic
Speed of sound	c	c2	m/s	Basic

#### *Homogenized Material*

- 1 Right-click **Materials** and choose **Blank Material**.
- 2 In the **Settings** window for **Material**, type Homogenized Material in the **Label** text field.
- 3 Locate the **Geometric Entity Selection** section. From the **Selection** list, choose **Selection: Homogenized Cloak**.
- 4 Click to expand the **Material Properties** section. In the **Material properties** tree, select **Acoustics > Anisotropic Acoustics Model > Effective bulk modulus (K\_eff)**.
- 5 Click **+ Add to Material**.
- 6 In the **Material properties** tree, select **Acoustics > Anisotropic Acoustics Model > Effective density (rho\_eff)**.

7 Locate the **Material Contents** section. In the table, enter the following settings:

Property	Variable	Value	Unit	Property group
Effective density	{rho_eff11, rho_eff22, rho_eff33}; rho_effij = 0	{rho_normal, rho_tangential, rho_tangential}	kg/m <sup>3</sup>	Anisotropic acoustics model
Effective bulk modulus	K_eff	K	Pa	Anisotropic acoustics model
Density	rho		kg/m <sup>3</sup>	Basic
Speed of sound	c		m/s	Basic

The homogenized material has a diagonal density matrix with terms that change value with the radius. The bulk modulus also varies with the radius.

## PRESSURE ACOUSTICS, FREQUENCY DOMAIN (ACPR)

### *Homogenized Model*

- 1 In the **Model Builder** window, under **Component 1 (comp1)** right-click **Pressure Acoustics, Frequency Domain (acpr)** and choose **Node Group**.
- 2 In the **Settings** window for **Group**, type Homogenized Model in the **Label** text field.

The outer boundaries need a radiation condition to make sure that no waves are reflected at this interface.

### *Cylindrical Wave Radiation 1*

- 1 In the **Physics** toolbar, click  **Boundaries** and choose **Cylindrical Wave Radiation**.
- 2 Select Boundary 154 only.
- 3 In the **Settings** window for **Cylindrical Wave Radiation**, locate the **Cylindrical Wave Radiation** section.
- 4 Specify the  $\mathbf{r}_0$  vector as

x1	x
y1	y

### *Homogenized Model*

Now, proceed to add a **Background Pressure Field** for each of the geometries. The field is a plane wave propagating in the **x** direction. The phase of this field is updated on each of the domains to make sure that the incident acoustic field is the same in all the domains.

#### *Background Pressure Field 1*

- 1 In the **Physics** toolbar, click  **Domains** and choose **Background Pressure Field**.
- 2 In the **Settings** window for **Background Pressure Field**, locate the **Domain Selection** section.
- 3 From the **Selection** list, choose **Selection: Homogenized Cloak Domain**.
- 4 Locate the **Background Pressure Field** section. In the  $p_0$  text field, type 1.
- 5 From the  $c$  list, choose **From material**.
- 6 From the **Material** list, choose **Air (mat1)**.
- 7 In the  $\phi$  text field, type `acpr.bp1.k*x1`.

#### *Symmetry 1*

- 1 In the **Physics** toolbar, click  **Boundaries** and choose **Symmetry**.
- 2 In the **Settings** window for **Symmetry**, locate the **Boundary Selection** section.
- 3 From the **Selection** list, choose **Selection: Symmetry Boundaries, Homogenized Cloak**.

#### *Anisotropic Acoustics 1*

- 1 In the **Physics** toolbar, click  **Domains** and choose **Anisotropic Acoustics**.
- 2 Select Domain 4 only.
- 3 In the **Settings** window for **Anisotropic Acoustics**, locate the **Coordinate System Selection** section.
- 4 From the **Coordinate system** list, choose **Cylindrical System 2 (sys2)**.

#### *No Cloak Model*

- 1 In the **Model Builder** window, right-click **Pressure Acoustics, Frequency Domain (acpr)** and choose **Node Group**.
- 2 In the **Settings** window for **Group**, type `No Cloak Model` in the **Label** text field.

#### *Cylindrical Wave Radiation 2*

- 1 In the **Physics** toolbar, click  **Boundaries** and choose **Cylindrical Wave Radiation**.
- 2 Select Boundary 209 only.
- 3 In the **Settings** window for **Cylindrical Wave Radiation**, locate the **Cylindrical Wave Radiation** section.

4 Specify the  $\mathbf{r}_0$  vector as

x2	x
y2	y

#### *Background Pressure Field 2*

- 1 In the **Physics** toolbar, click  **Domains** and choose **Background Pressure Field**.
- 2 In the **Settings** window for **Background Pressure Field**, locate the **Domain Selection** section.
- 3 From the **Selection** list, choose **Selection: No Cloak Domain**.
- 4 Locate the **Background Pressure Field** section. In the  $p_0$  text field, type 1.
- 5 From the  $c$  list, choose **From material**.
- 6 In the  $\phi$  text field, type `acpr.bp2.k*x2`.

#### *Symmetry 2*

- 1 In the **Physics** toolbar, click  **Boundaries** and choose **Symmetry**.
- 2 In the **Settings** window for **Symmetry**, locate the **Boundary Selection** section.
- 3 From the **Selection** list, choose **Selection: Symmetry Boundaries, No Cloak**.

#### *50 Layer Cloak Model*

- 1 Right-click **Pressure Acoustics, Frequency Domain (acpr)** and choose **Node Group**.
- 2 In the **Settings** window for **Group**, type 50 Layer Cloak Model in the **Label** text field.

#### *Cylindrical Wave Radiation 3*

- 1 In the **Physics** toolbar, click  **Boundaries** and choose **Cylindrical Wave Radiation**.
- 2 Select Boundary 153 only.
- 3 In the **Settings** window for **Cylindrical Wave Radiation**, locate the **Cylindrical Wave Radiation** section.
- 4 Specify the  $\mathbf{r}_0$  vector as

x3	x
y3	y

#### *Background Pressure Field 3*

- 1 In the **Physics** toolbar, click  **Domains** and choose **Background Pressure Field**.
- 2 In the **Settings** window for **Background Pressure Field**, locate the **Domain Selection** section.

- 3 From the **Selection** list, choose **Selection: 50 Layer Cloak Domain**.
- 4 Locate the **Background Pressure Field** section. In the  $p_0$  text field, type 1.
- 5 From the  $c$  list, choose **From material**.
- 6 In the  $\phi$  text field, type `acpr.bp3.k*x3`.

#### *Symmetry 3*

- 1 In the **Physics** toolbar, click  **Boundaries** and choose **Symmetry**.
- 2 In the **Settings** window for **Symmetry**, locate the **Boundary Selection** section.
- 3 From the **Selection** list, choose **Selection: Symmetry Boundaries, 50 Layer Cloak**.

#### *20 Layer Cloak Model*

- 1 Right-click **Pressure Acoustics, Frequency Domain (acpr)** and choose **Node Group**.
- 2 In the **Settings** window for **Group**, type 20 Layer Cloak Model in the **Label** text field.

#### *Cylindrical Wave Radiation 4*

- 1 In the **Physics** toolbar, click  **Boundaries** and choose **Cylindrical Wave Radiation**.
- 2 Select Boundary 208 only.
- 3 In the **Settings** window for **Cylindrical Wave Radiation**, locate the **Cylindrical Wave Radiation** section.
- 4 Specify the  $\mathbf{r}_0$  vector as

x4	x
y4	y

#### *Background Pressure Field 4*

- 1 In the **Physics** toolbar, click  **Domains** and choose **Background Pressure Field**.
- 2 In the **Settings** window for **Background Pressure Field**, locate the **Domain Selection** section.
- 3 From the **Selection** list, choose **Selection: 20 Layer Cloak Domain**.
- 4 Locate the **Background Pressure Field** section. In the  $p_0$  text field, type 1.
- 5 From the  $c$  list, choose **From material**.
- 6 In the  $\phi$  text field, type `acpr.bp4.k*x4`.

#### *Symmetry 4*

- 1 In the **Physics** toolbar, click  **Boundaries** and choose **Symmetry**.
- 2 In the **Settings** window for **Symmetry**, locate the **Boundary Selection** section.
- 3 From the **Selection** list, choose **Selection: Symmetry Boundaries, 20 Layer Cloak**.

## MESH 1

In this model, the mesh is set up manually. Proceed by directly adding the desired mesh component.

### *Free Triangular 1*

In the **Mesh** toolbar, click  **Free Triangular**.

### *Size*

- 1 In the **Model Builder** window, click **Size**.
- 2 In the **Settings** window for **Size**, locate the **Element Size** section.
- 3 Click the **Custom** button.
- 4 Locate the **Element Size Parameters** section. In the **Maximum element size** text field, type  $1\text{m}0/6$ .

In general, five to six second-order elements per wavelength are needed to resolve the waves. For more details, see *Meshing (Resolving the Waves)* in the *Acoustics Module User's Guide*. This model uses six elements per wavelength.

- 5 Click  **Build Selected**.

Add a mapped mesh in the acoustic cloak domains. As the domains have properties that change with the radius, it is a good idea to keep a structured mesh with elements along the varying direction.

### *Mapped 1*

- 1 In the **Mesh** toolbar, click  **Mapped**.
- 2 In the **Settings** window for **Mapped**, locate the **Domain Selection** section.
- 3 From the **Geometric entity level** list, choose **Domain**.
- 4 From the **Selection** list, choose **Selection: Acoustic Cloak**.

Since the variation of properties is more pronounced toward the inner center of the acoustic cloak, add a skewed distribution to make sure that the mesh is sufficiently fine throughout the domain.

### *Distribution 1*

- 1 Right-click **Mapped 1** and choose **Distribution**.
- 2 Select Boundary 4 only.
- 3 In the **Settings** window for **Distribution**, locate the **Distribution** section.
- 4 From the **Distribution type** list, choose **Predefined**.
- 5 In the **Number of elements** text field, type 20.

**6** In the **Element ratio** text field, type 4.

The same distribution should be applied to the other edge of the domain, but with the reverse direction.

#### *Distribution 2*

**1** In the **Model Builder** window, right-click **Mapped 1** and choose **Distribution**.

**2** Select Boundary 55 only.

**3** In the **Settings** window for **Distribution**, locate the **Distribution** section.

**4** From the **Distribution type** list, choose **Predefined**.

**5** In the **Number of elements** text field, type 20.

**6** In the **Element ratio** text field, type 4.

**7** Select the **Reverse direction** checkbox.

#### *Distribution 3*

**1** Right-click **Mapped 1** and choose **Distribution**.

**2** Select Boundary 156 only.

**3** In the **Settings** window for **Distribution**, locate the **Distribution** section.

**4** In the **Number of elements** text field, type 40.

- 5 In the **Model Builder** window, right-click **Mesh 1** and choose **Build All**.

The mesh should look like this.

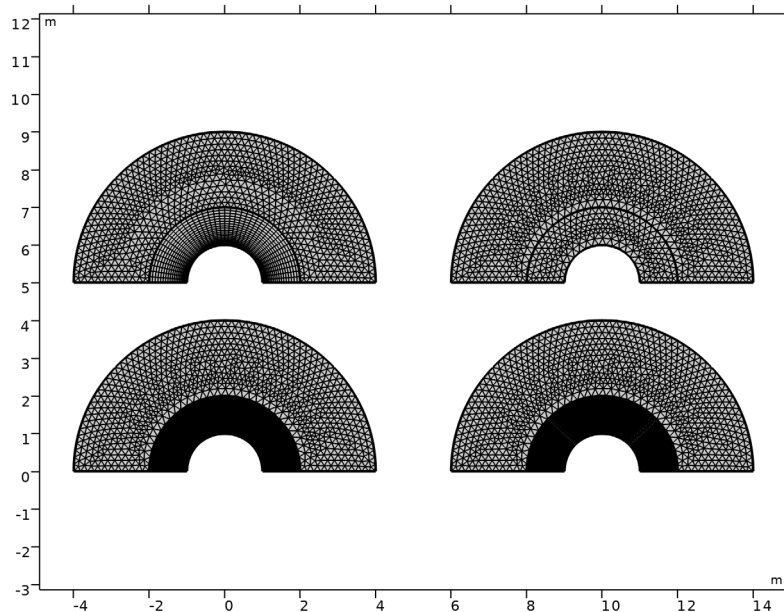

## STUDY 1

*Step 1: Frequency Domain*

- 1 In the **Model Builder** window, under **Study 1** click **Step 1: Frequency Domain**.
- 2 In the **Settings** window for **Frequency Domain**, locate the **Study Settings** section.
- 3 In the **Frequencies** text field, type  $f_0$ .
- 4 In the **Study** toolbar, click **Compute**.

The following steps will update the default plots to include a cleaner view of the model with annotations of the different cloaks.

## RESULTS

*Total Acoustic Pressure (acpr)*

- 1 In the **Settings** window for **2D Plot Group**, type Total Acoustic Pressure (acpr) in the **Label** text field.
- 2 Locate the **Plot Settings** section. Clear the **Plot dataset edges** checkbox.

### Line 1

- 1 Right-click **Total Acoustic Pressure (acpr)** and choose **Line**.
- 2 In the **Settings** window for **Line**, locate the **Expression** section.
- 3 In the **Expression** text field, type 0.
- 4 Click to expand the **Title** section. From the **Title type** list, choose **None**.
- 5 Locate the **Coloring and Style** section. From the **Coloring** list, choose **Uniform**.
- 6 From the **Color** list, choose **Black**.

### Selection 1

- 1 Right-click **Line 1** and choose **Selection**.
- 2 Select Boundaries 1, 2, 105–108, 151–156, and 208–211 only.
- 3 In the **Total Acoustic Pressure (acpr)** toolbar, click  **Plot**.



### Total Acoustic Pressure (acpr)

In the **Model Builder** window, under **Results** click **Total Acoustic Pressure (acpr)**.

### Table Annotation 1

- 1 In the **Total Acoustic Pressure (acpr)** toolbar, click  **More Plots** and choose **Table Annotation**.
- 2 In the **Settings** window for **Table Annotation**, locate the **Data** section.
- 3 From the **Source** list, choose **Local table**.
- 4 In the table, enter the following settings:

x-coordinate	y-coordinate	Annotation
x1	y1+4.3[m]	Homogenized cloak
x2	y2+4.3[m]	No cloak
x3	y3+4.3[m]	50 Layer cloak
x4	y4+4.3[m]	20 Layer cloak

- 5 Locate the **Coloring and Style** section. Clear the **Show point** checkbox.
- 6 From the **Anchor point** list, choose **Center**.
- 7 In the **Total Acoustic Pressure (acpr)** toolbar, click  **Plot**.
- 8 Click the  **Zoom Extents** button in the **Graphics** toolbar.

### Total Acoustic Pressure (acpr)

- 1 In the **Model Builder** window, click **Total Acoustic Pressure (acpr)**.

- 2 In the **Total Acoustic Pressure (acpr)** toolbar, click  **Plot**.

The plot should look like that in [Figure 2](#).

#### *Sound Pressure Level (acpr)*

- 1 In the **Model Builder** window, right-click **Sound Pressure Level (acpr)** and choose **Delete**.  
Remove the default Sound Pressure Level plot and duplicate the Total Acoustic Pressure plot created previously. Doing this, you make sure that the annotations will be carried over to the new plots.

#### *Total Sound Pressure Level (acpr)*

- 1 In the **Model Builder** window, right-click **Total Acoustic Pressure (acpr)** and choose **Duplicate**.
- 2 In the **Settings** window for **2D Plot Group**, type Total Sound Pressure Level (acpr) in the **Label** text field.

#### *Surface 1*

- 1 In the **Model Builder** window, expand the **Total Sound Pressure Level (acpr)** node, then click **Surface 1**.
- 2 In the **Settings** window for **Surface**, locate the **Expression** section.
- 3 In the **Expression** text field, type `acpr.Lp_t`.
- 4 Locate the **Coloring and Style** section. From the **Color table** list, choose **Rainbow**.
- 5 From the **Scale** list, choose **Linear**.
- 6 In the **Total Sound Pressure Level (acpr)** toolbar, click  **Plot**.  
The plot should look like that in [Figure 3](#).

#### *Scattered Sound Pressure Level (acpr)*

- 1 In the **Model Builder** window, right-click **Total Sound Pressure Level (acpr)** and choose **Duplicate**.
- 2 In the **Settings** window for **2D Plot Group**, type Scattered Sound Pressure Level (acpr) in the **Label** text field.

#### *Surface 1*



- 1 In the **Model Builder** window, expand the **Scattered Sound Pressure Level (acpr)** node, then click **Surface 1**.
- 2 In the **Settings** window for **Surface**, locate the **Expression** section.
- 3 In the **Expression** text field, type `acpr.Lp_s`.

### *Selection 1*

- 1 Right-click **Surface 1** and choose **Selection**.
- 2 Select Domains 1, 2, 54, and 55 only.
- 3 In the **Scattered Sound Pressure Level (acpr)** toolbar, click  **Plot**.

The plot should look like that in [Figure 4](#).

### *Effective Speed of Sound in Principal Directions*

- 1 In the **Results** toolbar, click  **2D Plot Group**.
- 2 In the **Settings** window for **2D Plot Group**, type **Effective Speed of Sound in Principal Directions** in the **Label** text field.
- 3 Click to expand the **Selection** section. From the **Geometric entity level** list, choose **Domain**.
- 4 Select Domain 4 only.
- 5 Locate the **Plot Settings** section. From the **View** list, choose **New view** to create a dedicated view for this plot.
- 6 Locate the **Selection** section. Select the **Apply to dataset edges** checkbox.
- 7 Click the  **Zoom Extents** button in the **Graphics** toolbar.
- 8 In the **Effective Speed of Sound in Principal Directions** toolbar, click  **Plot**.
- 9 Click to expand the **Title** section. From the **Title type** list, choose **Label**.

### *Principal Stress Surface 1*

- 1 In the **Effective Speed of Sound in Principal Directions** toolbar, click  **More Plots** and choose **Principal Stress Surface**.
- 2 In the **Settings** window for **Principal Stress Surface**, locate the **Principal Components** section.
- 3 Find the **Principal values** subsection. In row **Value**, set **Second** to 0.
- 4 In row **Value**, set **Third** to 0.5.
- 5 Find the **Principal directions** subsection. In row **X**, set **First** to `acpr.c_eff1x+acpr.c_eff2x`.
- 6 In row **Y**, set **First** to `acpr.c_eff1y+acpr.c_eff2y`.
- 7 In row **Y**, set **Second** to 0.
- 8 In row **X**, set **Third** to `acpr.c_eff3x`.
- 9 In row **Y**, set **Third** to `acpr.c_eff3y`.

**10** In row **Z**, set **Third** to 0.

The first and second effective speeds of sound are identical in magnitude, but one of them is perpendicular to the plane. Both terms are added to the first direction so that the arrows are consistent.

**11** In the **Effective Speed of Sound in Principal Directions** toolbar, click  **Plot**.

The plot should look like this.

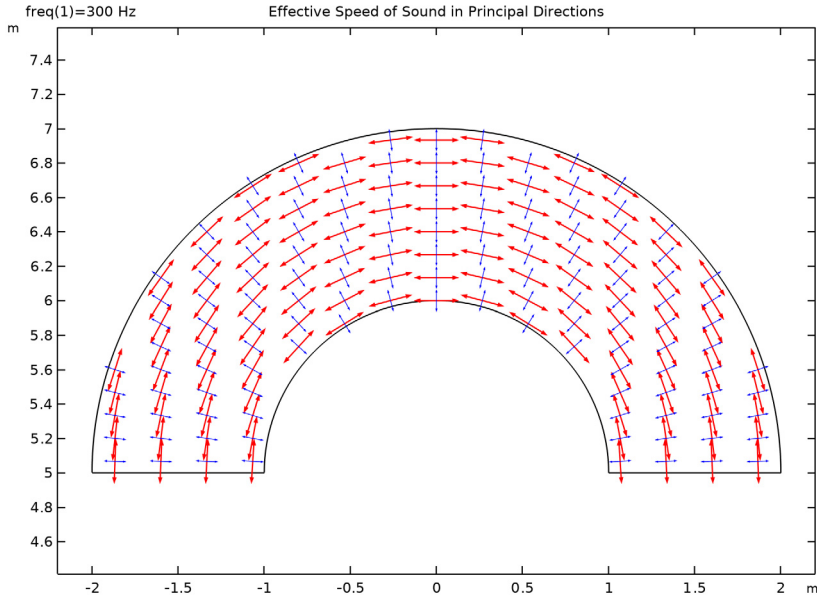

#### *Total Acoustic Pressure Along Cloak Boundary*

- 1** In the **Home** toolbar, click  **Add Plot Group** and choose **ID Plot Group**.
- 2** In the **Settings** window for **ID Plot Group**, type Total Acoustic Pressure Along Cloak Boundary in the **Label** text field.
- 3** Click to expand the **Title** section. From the **Title type** list, choose **Label**.
- 4** Locate the **Plot Settings** section.
- 5** Select the **y-axis label** checkbox. In the associated text field, type Pressure (Pa).

#### *Line Graph 1*

- 1** Right-click **Total Acoustic Pressure Along Cloak Boundary** and choose **Line Graph**.
- 2** Select Boundary 156 only.
- 3** In the **Settings** window for **Line Graph**, locate the **y-Axis Data** section.

- 4 In the **Expression** text field, type `acpr.p_b`.
- 5 Click to expand the **Title** section. From the **Title type** list, choose **None**.
- 6 Click to expand the **Legends** section. Select the **Show legends** checkbox.
- 7 From the **Legends** list, choose **Manual**.
- 8 In the table, enter the following settings:

---

**Legends**

---

Background pressure field

---

- 9 Click to expand the **Coloring and Style** section. Find the **Line markers** subsection. From the **Marker** list, choose **Circle**.
- 10 From the **Positioning** list, choose **Interpolated**.
- 11 In the **Number** text field, type 100.
- 12 In the **Total Acoustic Pressure Along Cloak Boundary** toolbar, click  **Plot**.

#### *Line Graph 2*

- 1 Right-click **Line Graph 1** and choose **Duplicate**.
- 2 In the **Settings** window for **Line Graph**, locate the **y-Axis Data** section.
- 3 In the **Expression** text field, type `acpr.p_t`.
- 4 Locate the **Coloring and Style** section. Find the **Line markers** subsection. From the **Marker** list, choose **None**.
- 5 Locate the **Legends** section. In the table, enter the following settings:

---

**Legends**

---

Homogenized cloak model

---

#### *Line Graph 3*

- 1 Right-click **Line Graph 2** and choose **Duplicate**.
- 2 In the **Settings** window for **Line Graph**, locate the **Selection** section.
- 3 Click  **Clear Selection**.
- 4 Select Boundary 155 only.
- 5 Locate the **Legends** section. In the table, enter the following settings:

---

**Legends**

---

50 layer cloak model

---

#### Line Graph 4

- 1 Right-click **Line Graph 3** and choose **Duplicate**.
- 2 In the **Settings** window for **Line Graph**, locate the **Selection** section.
- 3 Click  **Clear Selection**.
- 4 Select Boundary 210 only.
- 5 Locate the **Legends** section. In the table, enter the following settings:

---

<b>Legends</b>
20 layer cloak model

---

- 6 In the **Total Acoustic Pressure Along Cloak Boundary** toolbar, click  **Plot**.  
The plot should look like that in [Figure 5](#).

#### Speed of Sound in Homogenized Material



- 1 In the **Results** toolbar, click  **ID Plot Group**.
- 2 In the **Settings** window for **ID Plot Group**, type Speed of Sound in Homogenized Material in the **Label** text field.
- 3 Locate the **Title** section. From the **Title type** list, choose **Label**.
- 4 Locate the **Plot Settings** section.
- 5 Select the **y-axis label** checkbox. In the associated text field, type Speed of sound (m/s).

#### Line Graph 1

- 1 Right-click **Speed of Sound in Homogenized Material** and choose **Line Graph**.
- 2 Select Boundary 55 only.
- 3 In the **Settings** window for **Line Graph**, locate the **y-Axis Data** section.
- 4 In the **Expression** text field, type `acpr.c_eff1`.
- 5 Locate the **x-Axis Data** section. From the **Parameter** list, choose **Expression**.
- 6 In the **Expression** text field, type `x`.
- 7 Locate the **Legends** section. Select the **Show legends** checkbox.
- 8 Find the **Include** subsection. Clear the **Solution** checkbox.
- 9 Select the **Description** checkbox.

#### Line Graph 2

- 1 Right-click **Line Graph 1** and choose **Duplicate**.
- 2 In the **Settings** window for **Line Graph**, locate the **y-Axis Data** section.

- 3 In the **Expression** text field, type `acpr.c_eff3`.
- 4 Click the  **y-Axis Log Scale** button in the **Graphics** toolbar.
- 5 In the **Speed of Sound in Homogenized Material** toolbar, click  **Plot**.  
The plot should look like that in [Figure 6](#).

## *Appendix: Geometry Sequence Instructions*

---

### **ADD COMPONENT**

In the **Home** toolbar, click  **Add Component** and choose **2D**.

### **GLOBAL DEFINITIONS**

#### *Parameters 1*

- 1 In the **Model Builder** window, under **Global Definitions** click **Parameters 1**.
- 2 In the **Settings** window for **Parameters**, locate the **Parameters** section.
- 3 Click  **Load from File**.
- 4 Browse to the model's Application Libraries folder and double-click the file `acoustic_cloaking_geom_sequence_parameters.txt`.

### **GEOMETRY 1**

#### *Circle 1 (c1)*

- 1 In the **Geometry** toolbar, click  **Circle**.
- 2 In the **Settings** window for **Circle**, locate the **Size and Shape** section.
- 3 In the **Radius** text field, type 4.
- 4 In the **Sector angle** text field, type 180.
- 5 Locate the **Position** section. In the **x** text field, type `x1`.
- 6 In the **y** text field, type `y1`.
- 7 Click to expand the **Layers** section. In the table, enter the following settings:

<b>Layer name</b>	<b>Thickness (m)</b>
Layer 1	R2
Layer 2	R1

#### *Circle 2 (c2)*

- 1 In the **Geometry** toolbar, click  **Circle**.

- 2 In the **Settings** window for **Circle**, locate the **Size and Shape** section.
- 3 In the **Radius** text field, type  $2 \cdot R2$ .
- 4 In the **Sector angle** text field, type 180.
- 5 Locate the **Position** section. In the **x** text field, type  $x2$ .
- 6 In the **y** text field, type  $y2$ .
- 7 Locate the **Layers** section. In the table, enter the following settings:

Layer name	Thickness (m)
Layer 1	R2
Layer 2	R1

*Circle 3 (c3)*

- 1 In the **Geometry** toolbar, click  **Circle**.
- 2 In the **Settings** window for **Circle**, locate the **Size and Shape** section.
- 3 In the **Radius** text field, type  $2 \cdot R2$ .
- 4 In the **Sector angle** text field, type 180.
- 5 Locate the **Position** section. In the **x** text field, type  $x3$ .
- 6 In the **y** text field, type  $y3$ .
- 7 Locate the **Layers** section. In the table, enter the following settings:

Layer name	Thickness (m)
Layer 1	R2
Layer 2	$(R2 - R1) / 50$
Layer 3	$(R2 - R1) / 50$
Layer 4	$(R2 - R1) / 50$
Layer 5	$(R2 - R1) / 50$
Layer 6	$(R2 - R1) / 50$
Layer 7	$(R2 - R1) / 50$
Layer 8	$(R2 - R1) / 50$
Layer 9	$(R2 - R1) / 50$
Layer 10	$(R2 - R1) / 50$
Layer 11	$(R2 - R1) / 50$
Layer 12	$(R2 - R1) / 50$
Layer 13	$(R2 - R1) / 50$
Layer 14	$(R2 - R1) / 50$

<b>Layer name</b>	<b>Thickness (m)</b>
Layer 15	$(R2 - R1) / 50$
Layer 16	$(R2 - R1) / 50$
Layer 17	$(R2 - R1) / 50$
Layer 18	$(R2 - R1) / 50$
Layer 19	$(R2 - R1) / 50$
Layer 20	$(R2 - R1) / 50$
Layer 21	$(R2 - R1) / 50$
Layer 22	$(R2 - R1) / 50$
Layer 23	$(R2 - R1) / 50$
Layer 24	$(R2 - R1) / 50$
Layer 25	$(R2 - R1) / 50$
Layer 26	$(R2 - R1) / 50$
Layer 27	$(R2 - R1) / 50$
Layer 28	$(R2 - R1) / 50$
Layer 29	$(R2 - R1) / 50$
Layer 30	$(R2 - R1) / 50$
Layer 31	$(R2 - R1) / 50$
Layer 32	$(R2 - R1) / 50$
Layer 33	$(R2 - R1) / 50$
Layer 34	$(R2 - R1) / 50$
Layer 35	$(R2 - R1) / 50$
Layer 36	$(R2 - R1) / 50$
Layer 37	$(R2 - R1) / 50$
Layer 38	$(R2 - R1) / 50$
Layer 39	$(R2 - R1) / 50$
Layer 40	$(R2 - R1) / 50$
Layer 41	$(R2 - R1) / 50$
Layer 42	$(R2 - R1) / 50$
Layer 43	$(R2 - R1) / 50$
Layer 44	$(R2 - R1) / 50$
Layer 45	$(R2 - R1) / 50$
Layer 46	$(R2 - R1) / 50$
Layer 47	$(R2 - R1) / 50$
Layer 48	$(R2 - R1) / 50$

Layer name	Thickness (m)
Layer 49	$(R2 - R1) / 50$
Layer 50	$(R2 - R1) / 50$
Layer 51	$(R2 - R1) / 50$

*Circle 4 (c4)*

- 1 In the **Geometry** toolbar, click  **Circle**.
- 2 In the **Settings** window for **Circle**, locate the **Size and Shape** section.
- 3 In the **Radius** text field, type  $2 * R2$ .
- 4 In the **Sector angle** text field, type 180.
- 5 Locate the **Position** section. In the **x** text field, type  $x4$ .
- 6 In the **y** text field, type  $y4$ .
- 7 Locate the **Layers** section. In the table, enter the following settings:

Layer name	Thickness (m)
Layer 1	R2
Layer 2	$(R2 - R1) / 20$
Layer 3	$(R2 - R1) / 20$
Layer 4	$(R2 - R1) / 20$
Layer 5	$(R2 - R1) / 20$
Layer 6	$(R2 - R1) / 20$
Layer 7	$(R2 - R1) / 20$
Layer 8	$(R2 - R1) / 20$
Layer 9	$(R2 - R1) / 20$
Layer 10	$(R2 - R1) / 20$
Layer 11	$(R2 - R1) / 20$
Layer 12	$(R2 - R1) / 20$
Layer 13	$(R2 - R1) / 20$
Layer 14	$(R2 - R1) / 20$
Layer 15	$(R2 - R1) / 20$
Layer 16	$(R2 - R1) / 20$
Layer 17	$(R2 - R1) / 20$
Layer 18	$(R2 - R1) / 20$
Layer 19	$(R2 - R1) / 20$
Layer 20	$(R2 - R1) / 20$
Layer 21	$(R2 - R1) / 20$

8 Click  **Build All Objects**.

9 Click the  **Zoom Extents** button in the **Graphics** toolbar.

#### *Delete Entities 1 (del1)*

1 In the **Model Builder** window, right-click **Geometry 1** and choose **Delete Entities**.

2 In the **Settings** window for **Delete Entities**, locate the **Entities or Objects to Delete** section.

3 From the **Geometric entity level** list, choose **Domain**.

4 On the object **c1**, select Domain 3 only.

5 On the object **c2**, select Domain 3 only.

6 On the object **c3**, select Domain 52 only.

7 On the object **c4**, select Domain 22 only.

8 Click  **Build Selected**.

The geometry should look like this.

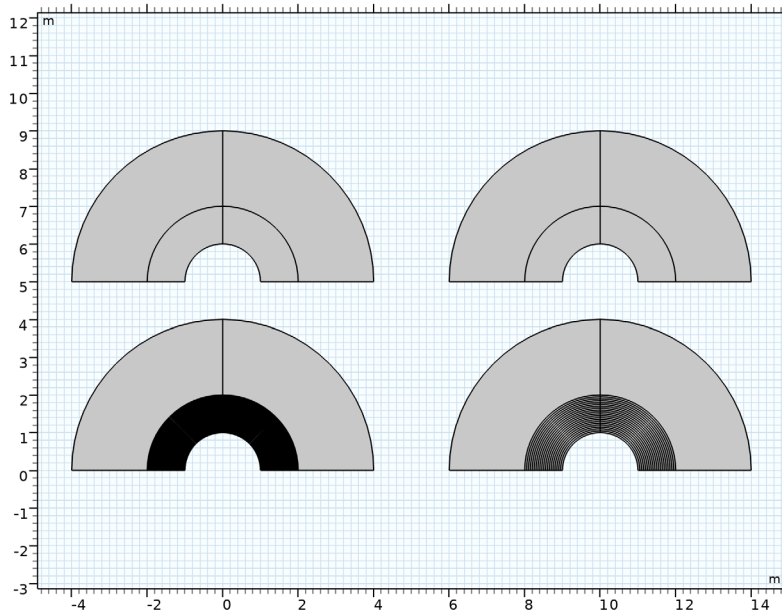

Now that the geometry has been generated, you can proceed to simplify some of its features.

#### *Ignore Edges 1 (ige1)*

1 In the **Geometry** toolbar, click  **Virtual Operations** and choose **Ignore Edges**.

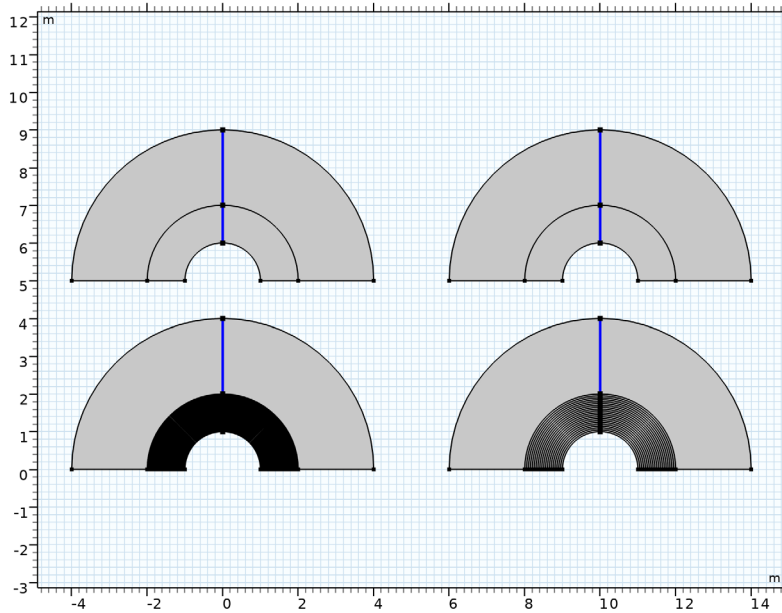

- 2 In the **Settings** window for **Ignore Edges**, locate the **Input** section.
- 3 Clear the **Ignore adjacent vertices** checkbox.
- 4 Click the  **Paste Selection** button for **Edges to ignore**.
- 5 In the **Paste Selection** dialog, type 54-106 183-205 in the **Selection** text field.
- 6 Click **OK**.

The selection should look like this.



- 7 In the **Settings** window for **Ignore Edges**, click  **Build Selected**.

*Ignore Vertices I (igvI)*

- 1 In the **Geometry** toolbar, click  **Virtual Operations** and choose **Ignore Vertices**.
- 2 In the **Settings** window for **Ignore Vertices**, locate the **Input** section.
- 3 Click the  **Paste Selection** button for **Vertices to ignore**.
- 4 In the **Paste Selection** dialog, type 56-110 191-215 in the **Selection** text field.

5 Click **OK**.

The selection should look like this.

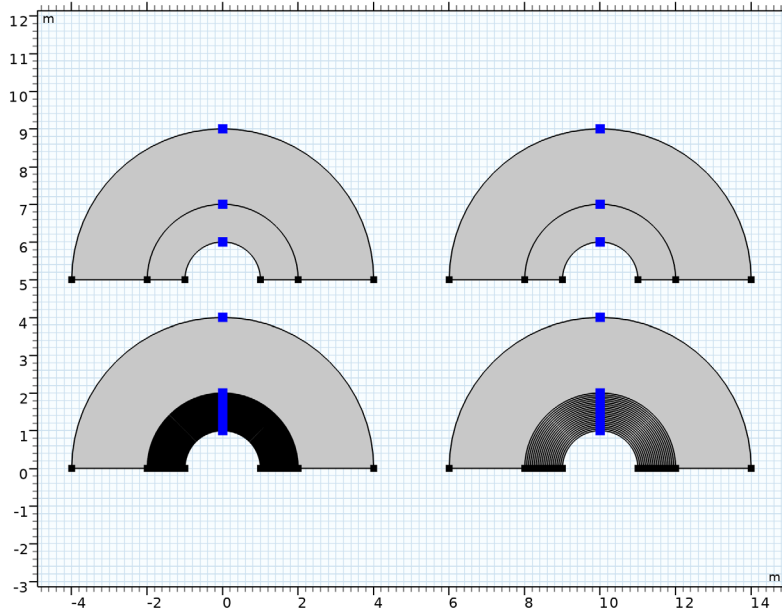



6 In the **Settings** window for **Ignore Vertices**, click  **Build Selected**.

With this clean geometry, you can proceed to generate a few selections that will be used in the model.

## GEOMETRY I

*Selection: Material 1*



- 1 In the **Geometry** toolbar, click  **Selections** and choose **Explicit Selection**.
- 2 In the **Settings** window for **Explicit Selection**, type Selection: Material 1 in the **Label** text field.
- 3 Locate the **Entities to Select** section. Click the  **Paste Selection** button for **Entities to select**.
- 4 In the **Paste Selection** dialog, type igv1: 5, 7, 9, 11, 13, 15, 17, 19, 21, 23, 25, 27, 29, 31, 33, 35, 37, 39, 41, 43, 45, 47, 49, 51, 53, 58, 60, 62, 64, 66, 68, 70, 72, 74, 76 in the **Selection** text field.

5 Click **OK**.

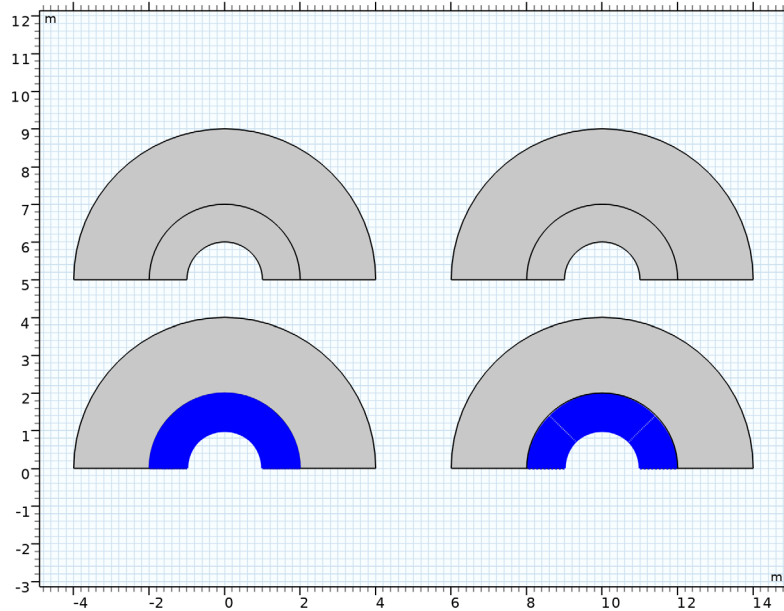
The selection should look like this.



*Selection: Material 2*



- 1 In the **Geometry** toolbar, click  **Selections** and choose **Explicit Selection**.
- 2 In the **Settings** window for **Explicit Selection**, type Selection: Material 2 in the **Label** text field.
- 3 Locate the **Entities to Select** section. Click the  **Paste Selection** button for **Entities to select**.
- 4 In the **Paste Selection** dialog, type igv1: 3, 6, 8, 10, 12, 14, 16, 18, 20, 22, 24, 26, 28, 30, 32, 34, 36, 38, 40, 42, 44, 46, 48, 50, 52, 56, 59, 61, 63, 65, 67, 69, 71, 73, 75 in the **Selection** text field.

5 Click **OK**.

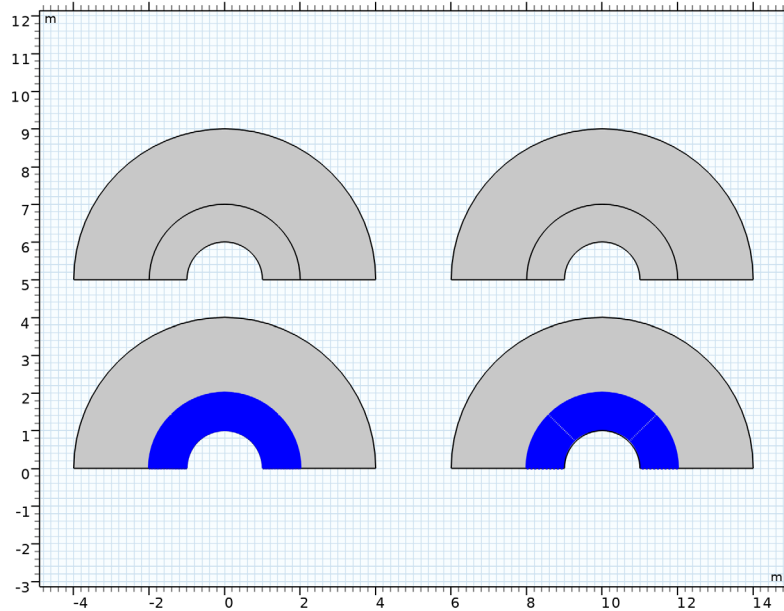
The selection should look like this.





*Selection: Homogenized Cloak*

- 1 In the **Geometry** toolbar, click  **Selections** and choose **Explicit Selection**.
- 2 In the **Settings** window for **Explicit Selection**, type Selection: Homogenized Cloak in the **Label** text field.
- 3 Locate the **Entities to Select** section. Click the  **Paste Selection** button for **Entities to select**.
- 4 In the **Paste Selection** dialog, type igv1: 4 in the **Selection** text field.
- 5 Click **OK**.
- 6 In the **Geometry** toolbar, click  **Build All**.



It is also possible to select entities based on their spatial position. Through the next steps you will add a few selections based on the position.

*Selection: 50 Layer Cloak*



- 1 In the **Geometry** toolbar, click  **Selections** and choose **Box Selection**.
- 2 In the **Settings** window for **Box Selection**, type Selection: 50 Layer Cloak in the **Label** text field.

- 3 Locate the **Box Limits** section. In the **x minimum** text field, type  $-2.5+x3$ .
- 4 In the **x maximum** text field, type  $2.5+x3$ .
- 5 In the **y minimum** text field, type  $0+y3$ .
- 6 In the **y maximum** text field, type  $2.5+y3$ .
- 7 Locate the **Output Entities** section. From the **Include entity if** list, choose **Entity inside box**.
- 8 Click  **Build Selected**.

*Selection: 20 Layer Cloak*

- 1 In the **Geometry** toolbar, click  **Selections** and choose **Box Selection**.
- 2 In the **Settings** window for **Box Selection**, type Selection: 20 Layer Cloak in the **Label** text field.
- 3 Locate the **Box Limits** section. In the **x minimum** text field, type  $-2.5+x4$ .
- 4 In the **x maximum** text field, type  $2.5+x4$ .
- 5 In the **y minimum** text field, type  $0+y4$ .
- 6 In the **y maximum** text field, type  $2.5+y4$ .
- 7 Locate the **Output Entities** section. From the **Include entity if** list, choose **Entity inside box**.
- 8 Click  **Build Selected**.

*Selection: Acoustic Cloak*

- 1 In the **Geometry** toolbar, click  **Selections** and choose **Union Selection**.
- 2 In the **Settings** window for **Union Selection**, type Selection: Acoustic Cloak in the **Label** text field.
- 3 Locate the **Input Entities** section. Click  **Add**.
- 4 In the **Add** dialog, in the **Selections to add** list, choose **Selection: Homogenized Cloak**, **Selection: 50 Layer Cloak**, and **Selection: 20 Layer Cloak**.
- 5 Click **OK**.

*Selection: Symmetry Boundaries, Homogenized Cloak*

- 1 In the **Geometry** toolbar, click  **Selections** and choose **Box Selection**.
- 2 In the **Settings** window for **Box Selection**, type Selection: Symmetry Boundaries, Homogenized Cloak in the **Label** text field.
- 3 Locate the **Geometric Entity Level** section. From the **Level** list, choose **Boundary**.
- 4 Locate the **Box Limits** section. In the **x minimum** text field, type  $-5+x1$ .

- 5 In the **x maximum** text field, type  $5+x1$ .
- 6 In the **y minimum** text field, type  $-0.5+y1$ .
- 7 In the **y maximum** text field, type  $0.5+y1$ .
- 8 Locate the **Output Entities** section. From the **Include entity if** list, choose **Entity inside box**.

*Selection: Symmetry Boundaries, No Cloak*

- 1 In the **Geometry** toolbar, click  **Selections** and choose **Box Selection**.
- 2 In the **Settings** window for **Box Selection**, type Selection: Symmetry Boundaries, No Cloak in the **Label** text field.
- 3 Locate the **Geometric Entity Level** section. From the **Level** list, choose **Boundary**.
- 4 Locate the **Box Limits** section. In the **x minimum** text field, type  $-5+x2$ .
- 5 In the **x maximum** text field, type  $5+x2$ .
- 6 In the **y minimum** text field, type  $-0.5+y2$ .
- 7 In the **y maximum** text field, type  $0.5+y2$ .
- 8 Locate the **Output Entities** section. From the **Include entity if** list, choose **Entity inside box**.

*Selection: Symmetry Boundaries, 50 Layer Cloak*

- 1 In the **Geometry** toolbar, click  **Selections** and choose **Box Selection**.
- 2 In the **Settings** window for **Box Selection**, type Selection: Symmetry Boundaries, 50 Layer Cloak in the **Label** text field.
- 3 Locate the **Geometric Entity Level** section. From the **Level** list, choose **Boundary**.
- 4 Locate the **Box Limits** section. In the **x minimum** text field, type  $-5+x3$ .
- 5 In the **x maximum** text field, type  $5+x3$ .
- 6 In the **y minimum** text field, type  $-0.5+y3$ .
- 7 In the **y maximum** text field, type  $0.5+y3$ .
- 8 Locate the **Output Entities** section. From the **Include entity if** list, choose **Entity inside box**.

*Selection: Symmetry Boundaries, 20 Layer Cloak*

- 1 In the **Geometry** toolbar, click  **Selections** and choose **Box Selection**.
- 2 In the **Settings** window for **Box Selection**, type Selection: Symmetry Boundaries, 20 Layer Cloak in the **Label** text field.
- 3 Locate the **Geometric Entity Level** section. From the **Level** list, choose **Boundary**.

- 4 Locate the **Box Limits** section. In the **x minimum** text field, type  $-5+x4$ .
- 5 In the **x maximum** text field, type  $5+x4$ .
- 6 In the **y minimum** text field, type  $-0.5+y4$ .
- 7 In the **y maximum** text field, type  $0.5+y4$ .
- 8 Locate the **Output Entities** section. From the **Include entity if** list, choose **Entity inside box**.

*Selection: Homogenized Cloak Domain*

- 1 In the **Geometry** toolbar, click  **Selections** and choose **Box Selection**.
- 2 In the **Settings** window for **Box Selection**, type Selection: Homogenized Cloak Domain in the **Label** text field.
- 3 Locate the **Box Limits** section. In the **x minimum** text field, type  $-5+x1$ .
- 4 In the **x maximum** text field, type  $5+x1$ .
- 5 In the **y minimum** text field, type  $-0.5+y1$ .
- 6 In the **y maximum** text field, type  $0.5+y1$ .

*Selection: No Cloak Domain*

- 1 In the **Geometry** toolbar, click  **Selections** and choose **Box Selection**.
- 2 In the **Settings** window for **Box Selection**, type Selection: No Cloak Domain in the **Label** text field.
- 3 Locate the **Box Limits** section. In the **x minimum** text field, type  $-5+x2$ .
- 4 In the **x maximum** text field, type  $5+x2$ .
- 5 In the **y minimum** text field, type  $-0.5+y2$ .
- 6 In the **y maximum** text field, type  $0.5+y2$ .

*Selection: 50 Layer Cloak Domain*

- 1 In the **Geometry** toolbar, click  **Selections** and choose **Box Selection**.
- 2 In the **Settings** window for **Box Selection**, type Selection: 50 Layer Cloak Domain in the **Label** text field.
- 3 Locate the **Box Limits** section. In the **x minimum** text field, type  $-5+x3$ .
- 4 In the **x maximum** text field, type  $5+x3$ .
- 5 In the **y minimum** text field, type  $-0.5+y3$ .
- 6 In the **y maximum** text field, type  $0.5+y3$ .

*Selection: 20 Layer Cloak Domain*

- 1 In the **Geometry** toolbar, click  **Selections** and choose **Box Selection**.

- 2 In the **Settings** window for **Box Selection**, type Selection: 20 Layer Cloak Domain in the **Label** text field.
- 3 Locate the **Box Limits** section. In the **x minimum** text field, type  $-5+x4$ .
- 4 In the **x maximum** text field, type  $5+x4$ .
- 5 In the **y minimum** text field, type  $-0.5+y4$ .
- 6 In the **y maximum** text field, type  $0.5+y4$ .
- 7 In the **Geometry** toolbar, click  **Build All**.