



Model created in COMSOL Multiphysics 6.4

Thin Low Permittivity Gap Comparison

Introduction

The thin low permittivity gap boundary condition is meant to approximate a thin layer of material with low relative permittivity compared to its surroundings, and is available for electrostatic field modeling. This example compares the thin low permittivity gap boundary condition to a full-fidelity model and discusses the range of applicability of this boundary condition.

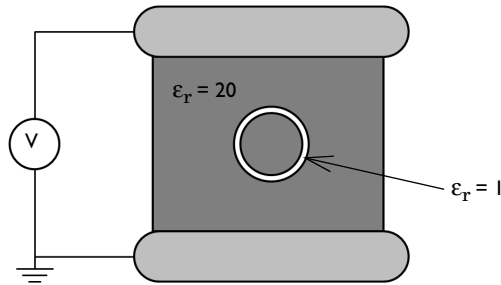

Figure 1: A two-dimensional parallel plate capacitor with a high dielectric between the plates. A thin circular gap in the high dielectric distorts the electric field.

Model Definition

The situation being modeled is shown in [Figure 1](#). Two parallel plates have a high dielectric material (relative permittivity $\epsilon_r = 20$) in between them, and have a voltage difference applied to them, forming a capacitor. Inside of this dielectric material, there is a 1 mm circular gap with lower permittivity ($\epsilon_r = 1$) and an outer diameter of 1 cm.

The thin gap is modeled in two different ways: first by using a full fidelity model that includes the thickness of the wall, and then by using the thin low permittivity gap boundary condition. The two models are separate, but are modeled simultaneously for comparison.

The location of the thin low permittivity gap condition is at the centerline, midway between the inner and outer radii of the gap in the full fidelity model. Note that when using the thin low permittivity gap condition, the total volume of the surrounding material is slightly larger, since the thickness of the wall is not being explicitly modeled.

Results and Discussion

The electric field and isolines of the voltage are plotted in Figure 2. The field lines can be observed to deform around the inclusion. The solution for the model using the thin low permittivity gap condition agrees well with the one in the full fidelity model.

The thin low permittivity gap boundary condition can be used in cases where the thickness of the boundary being approximated is much smaller than the characteristic size of the model domain, and when the relative permittivity of the gap region is lower than the surrounding medium. When this boundary condition is used, the number of mesh elements is much smaller, saving solution time and memory.

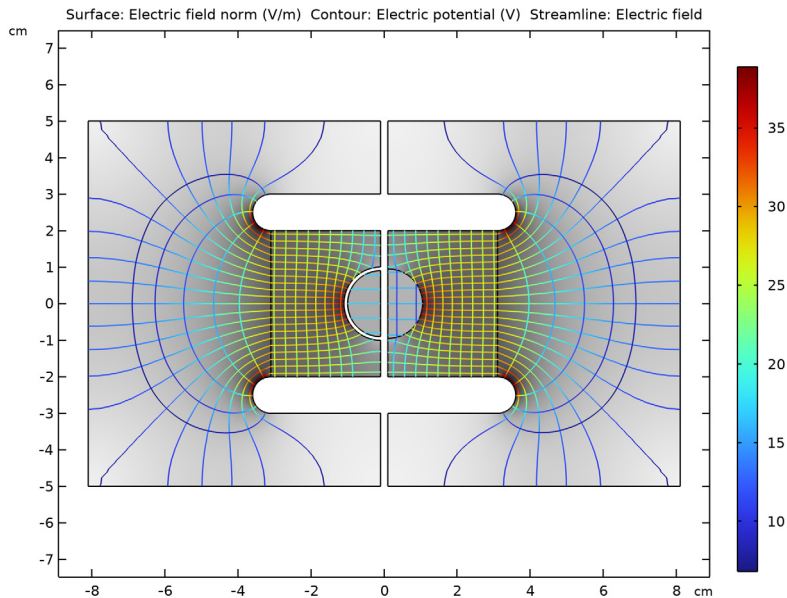



Figure 2: Isolines of the voltage field and streamlines of the electric field are plotted. The lines are colored according to the strength of the electric field, and the background grayscale plot is of the electric field norm. The full fidelity (left) and thin low permittivity gap (right) solutions are almost identical.

Application Library path: ACDC_Module/Introductory_Electrostatics/
thin_low_permittivity_gap_comparison



Modeling Instructions

From the **File** menu, choose **New**.

NEW

In the **New** window, click  **Model Wizard**.

MODEL WIZARD

- 1 In the **Model Wizard** window, click  **2D**.
- 2 In the **Select Physics** tree, select **AC/DC** > **Electric Fields and Currents** > **Electrostatics (es)**.
- 3 Click **Add**.
- 4 Click  **Study**.
- 5 In the **Select Study** tree, select **General Studies** > **Stationary**.
- 6 Click  **Done**.

GEOMETRY I

- 1 In the **Model Builder** window, under **Component 1 (comp1)** click **Geometry 1**.
- 2 In the **Settings** window for **Geometry**, locate the **Units** section.
- 3 From the **Length unit** list, choose **cm**.

GLOBAL DEFINITIONS

Parameters 1

- 1 In the **Model Builder** window, under **Global Definitions** click **Parameters 1**.
- 2 In the **Settings** window for **Parameters**, locate the **Parameters** section.
- 3 In the table, enter the following settings:

Name	Expression	Value	Description
er_a	1	1	Relative permittivity, free space and gap
er_b	20	20	Relative permittivity, dielectric
V0	1[V]	1 V	Applied voltage

GEOMETRY I

Rectangle 1 (r1)

- 1 In the **Geometry** toolbar, click  **Rectangle**.
- 2 In the **Settings** window for **Rectangle**, locate the **Size and Shape** section.

- 3 In the **Width** text field, type 8.
- 4 In the **Height** text field, type 10.
- 5 Locate the **Position** section. In the **x** text field, type 0.1.
- 6 In the **y** text field, type -5.

Rectangle 2 (r2)

- 1 In the **Geometry** toolbar, click  **Rectangle**.
- 2 In the **Settings** window for **Rectangle**, locate the **Size and Shape** section.
- 3 In the **Width** text field, type 3.5.
- 4 Locate the **Position** section. In the **x** text field, type 0.1.
- 5 In the **y** text field, type 2.

Fillet 1 (fil1)

- 1 In the **Geometry** toolbar, click  **Fillet**.
- 2 On the object **r2**, select Points 2 and 3 only.

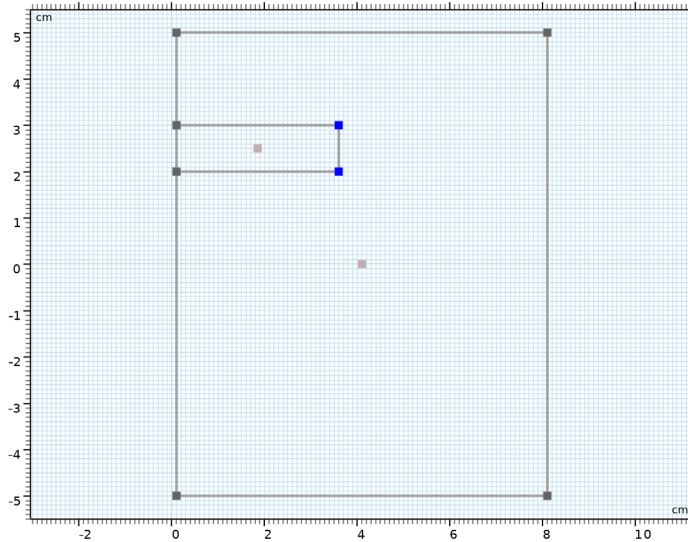

- 3 In the **Settings** window for **Fillet**, locate the **Radius** section.
- 4 In the **Radius** text field, type 0.5.

Copy 1 (copy1)



- 1 In the **Geometry** toolbar, click  **Transforms** and choose **Copy**.
- 2 Select the object **fil1** only.

- 3 In the **Settings** window for **Copy**, locate the **Displacement** section.
- 4 In the **y** text field, type -5.

Rectangle 3 (r3)

- 1 In the **Geometry** toolbar, click  **Rectangle**.
- 2 In the **Settings** window for **Rectangle**, locate the **Size and Shape** section.
- 3 In the **Width** text field, type 3.
- 4 In the **Height** text field, type 4.
- 5 Locate the **Position** section. In the **x** text field, type 0.1.
- 6 In the **y** text field, type -2.

Mirror 1 (mir1)

- 1 In the **Geometry** toolbar, click  **Transforms** and choose **Mirror**.
- 2 Click in the **Graphics** window and then press Ctrl+A to select all objects.
- 3 In the **Settings** window for **Mirror**, locate the **Input** section.
- 4 Select the **Keep input objects** checkbox.
- 5 Click  **Build Selected**.
- 6 Click the  **Zoom Extents** button in the **Graphics** toolbar.

Circle 1 (c1)

- 1 In the **Geometry** toolbar, click  **Circle**.
- 2 In the **Settings** window for **Circle**, locate the **Size and Shape** section.
- 3 In the **Radius** text field, type 0.95.
- 4 In the **Sector angle** text field, type 180.
- 5 Locate the **Position** section. In the **x** text field, type 0.1.
- 6 Locate the **Rotation Angle** section. In the **Rotation** text field, type -90.

Circle 2 (c2)

- 1 In the **Geometry** toolbar, click  **Circle**.
- 2 In the **Settings** window for **Circle**, locate the **Size and Shape** section.
- 3 In the **Sector angle** text field, type 180.
- 4 Locate the **Position** section. In the **x** text field, type -0.1.
- 5 Locate the **Rotation Angle** section. In the **Rotation** text field, type 90.

6 Click to expand the **Layers** section. In the table, enter the following settings:

Layer name	Thickness (cm)
Layer 1	1 [mm]

7 Click  **Build All Objects**.

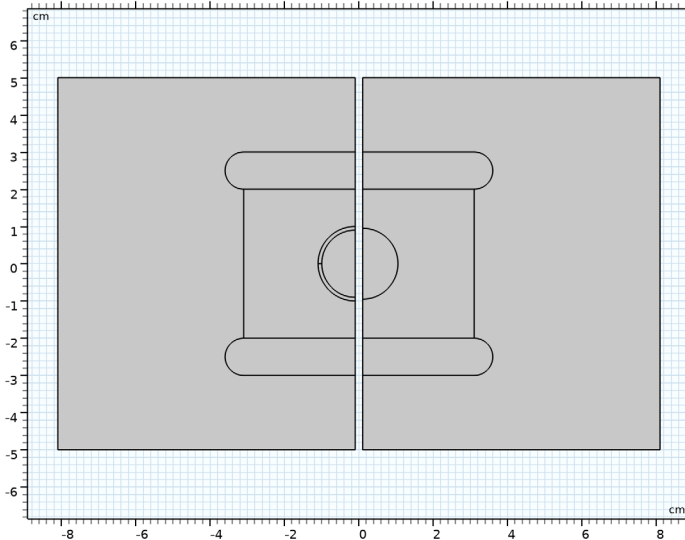

The geometry on the left side describes the full fidelity model. The geometry on the right side replaces the thin layer with a boundary in order to use the **Thin Low Permittivity Gap** feature.

DEFINITIONS

Create a set of selections before setting up the physics. First, create a selection for the high dielectric material domain between two parallel plates.

High dielectric

1 In the **Definitions** toolbar, click  **Explicit**.

2 Select Domains 3, 7, 10, and 11 only.

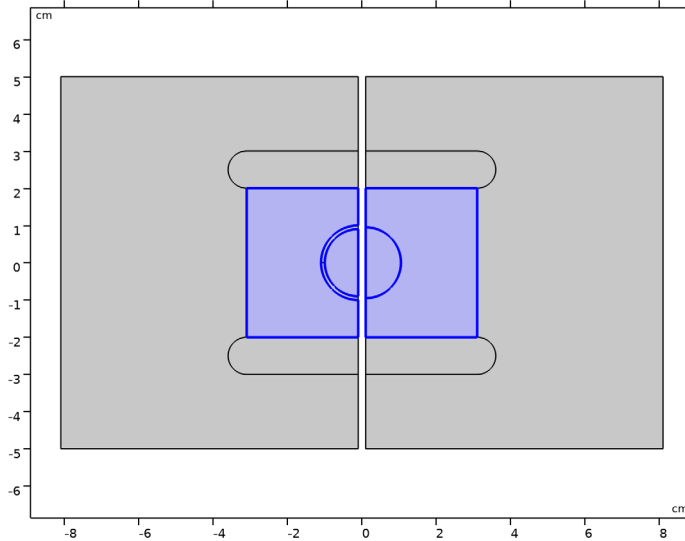

3 In the **Settings** window for **Explicit**, type High dielectric in the **Label** text field. Add a selection for the thin low permittivity gap boundaries.

Thin low permittivity gap

- 1 In the **Definitions** toolbar, click  **Explicit**.
- 2 In the **Settings** window for **Explicit**, locate the **Input Entities** section.
- 3 From the **Geometric entity level** list, choose **Boundary**.

4 Select Boundaries 44 and 45 only.

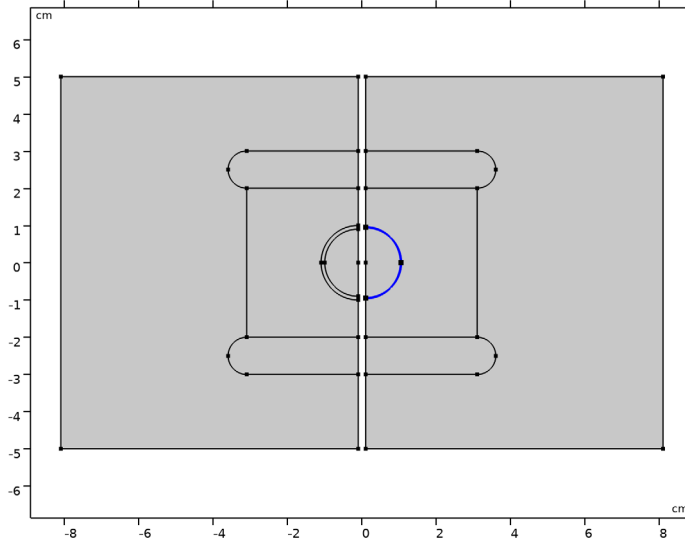

5 In the **Label** text field, type Thin low permittivity gap.

Add a selection for the model domain.

Model domain

1 In the **Definitions** toolbar, click  **Explicit**.

2 Select Domains 1, 3, 5–8, 10, and 11 only.

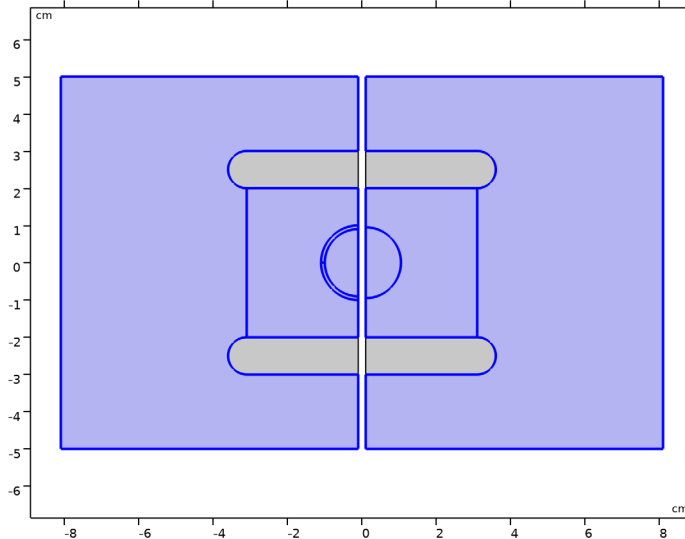

3 In the **Settings** window for **Explicit**, type Model domain in the **Label** text field. Now, add the physics features needed for the two sides of the model.

ELECTROSTATICS (ES)

Charge Conservation in Solids I

- 1 In the **Physics** toolbar, click  **Domains** and choose **Charge Conservation in Solids**.
- 2 Select Domains 3, 7, 10, and 11 only.
- 3 In the **Model Builder** window, click **Electrostatics (es)**.
- 4 In the **Settings** window for **Electrostatics**, locate the **Domain Selection** section.
- 5 From the **Selection** list, choose **Model domain**.

Ground I

- 1 In the **Physics** toolbar, click  **Boundaries** and choose **Ground**.

2 Select Boundaries 23, 25, 46, and 47 only.

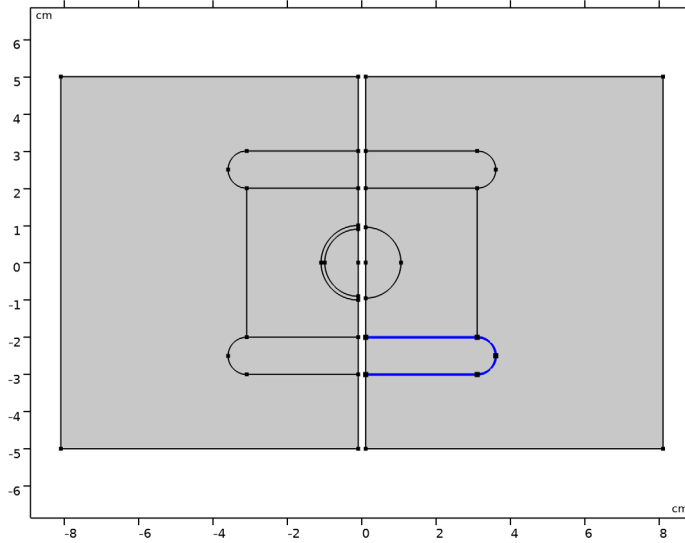

Ground 2

1 In the **Physics** toolbar, click  **Boundaries** and choose **Ground**.

2 Select Boundaries 4, 6, 36, and 37 only.

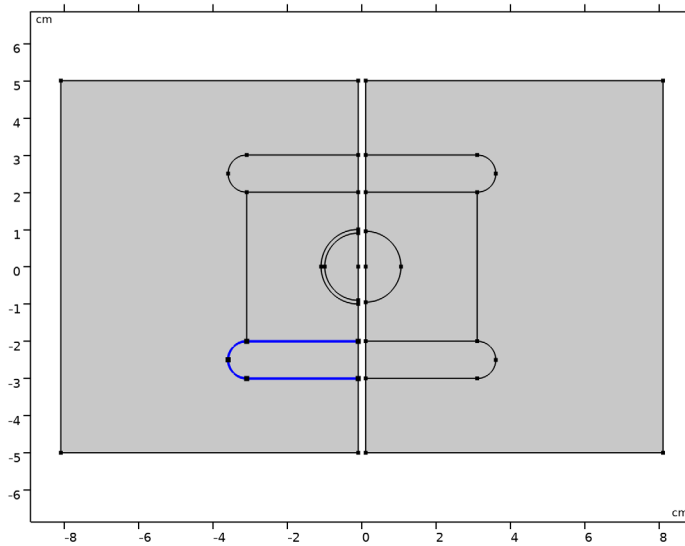

Boundary Terminal 1

- 1 In the **Physics** toolbar, click  **Boundaries** and choose **Boundary Terminal**.
- 2 Select Boundaries 30, 32, 48, and 49 only.

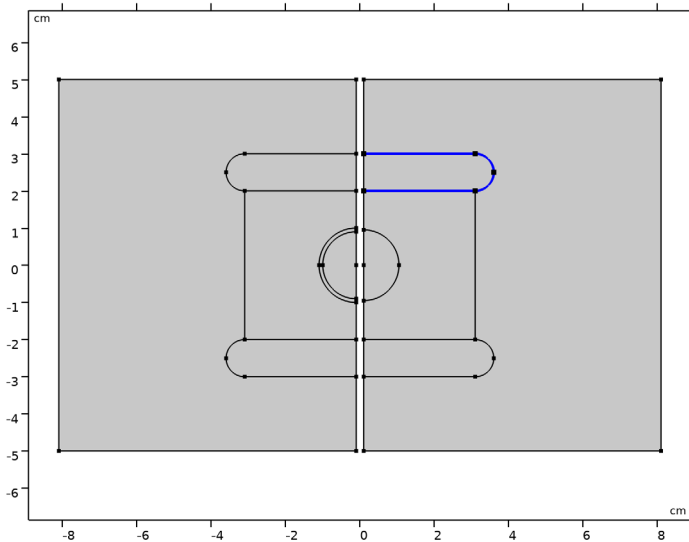

- 3 In the **Settings** window for **Boundary Terminal**, locate the **Terminal** section.
- 4 From the **Terminal type** list, choose **Voltage**.
- 5 In the V_0 text field, type V_0 .

Boundary Terminal 2

- 1 In the **Physics** toolbar, click  **Boundaries** and choose **Boundary Terminal**.

2 Select Boundaries 7, 8, 38, and 39 only.

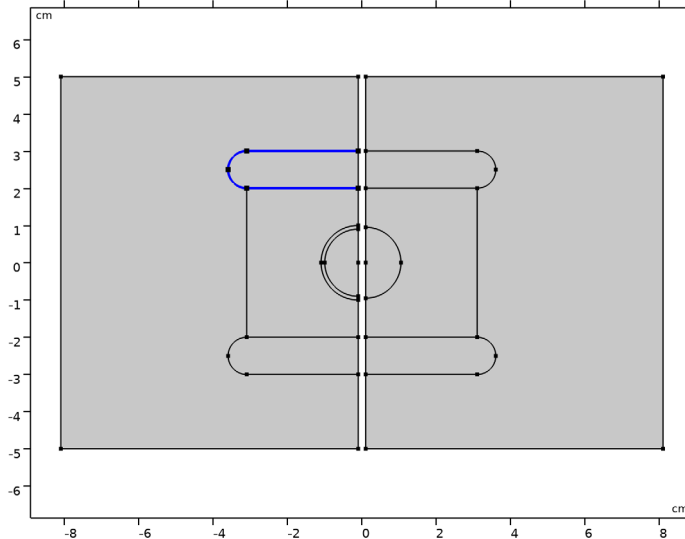

3 In the **Settings** window for **Boundary Terminal**, locate the **Terminal** section.

4 From the **Terminal type** list, choose **Voltage**.

5 In the V_0 text field, type V_0 .

Thin Low Permittivity Gap 1

1 In the **Physics** toolbar, click  **Boundaries** and choose **Thin Low Permittivity Gap**.

2 In the **Settings** window for **Thin Low Permittivity Gap**, locate the **Boundary Selection** section.

3 From the **Selection** list, choose **Thin low permittivity gap**.

4 Locate the **Thin Low Permittivity Gap** section. In the d_s text field, type 1 [mm].

MATERIALS

Material 1 (mat1)

1 In the **Model Builder** window, under **Component 1 (comp1)** right-click **Materials** and choose **Blank Material**.

2 In the **Settings** window for **Material**, locate the **Geometric Entity Selection** section.

3 From the **Selection** list, choose **High dielectric**.

4 Locate the **Material Contents** section. In the table, enter the following settings:

Property	Variable	Value	Unit	Property group
Relative permittivity	epsilon _{r_ii} ; epsilon _{r_ii} = epsilon _{r_ii} ; epsilon _{r_ii} = 0	er_b		Basic

Material 2 (mat2)

1 Right-click **Materials** and choose **Blank Material**.

2 In the **Settings** window for **Material**, locate the **Geometric Entity Selection** section.

3 From the **Geometric entity level** list, choose **Boundary**.

4 From the **Selection** list, choose **Thin low permittivity gap**.

5 Locate the **Material Contents** section. In the table, enter the following settings:

Property	Variable	Value	Unit	Property group
Relative permittivity	epsilon _{r_ii} ; epsilon _{r_ii} = epsilon _{r_ii} ; epsilon _{r_ii} = 0	er_a		Basic

MESH I

In the **Model Builder** window, under **Component 1 (comp1)** right-click **Mesh 1** and choose **Build All**.

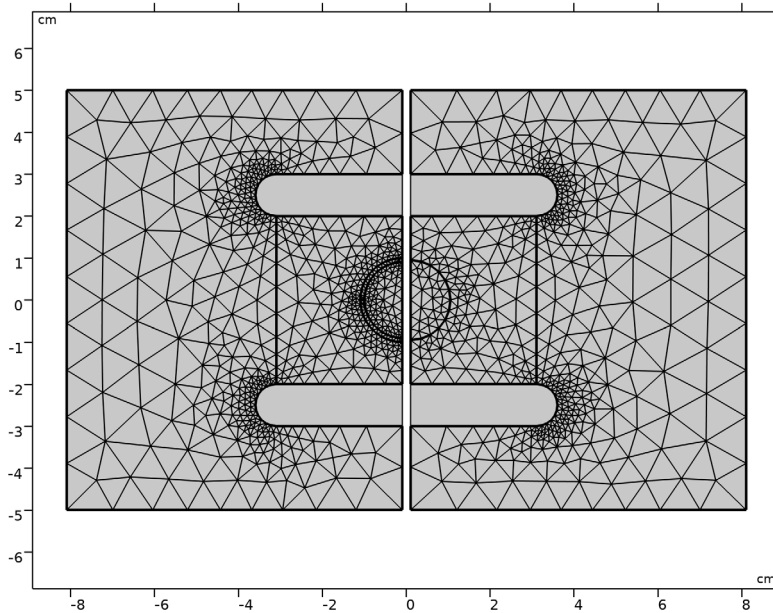

STUDY I

- 1 In the **Model Builder** window, click **Study 1**.
- 2 In the **Settings** window for **Study**, locate the **Study Settings** section.
- 3 Clear the **Generate default plots** checkbox.
- 4 In the **Study** toolbar, click **Compute**.

Begin the result analysis by suppressing the domain of the wall of the inclusion, which is not of interest.

RESULTS

In the **Model Builder** window, expand the **Results** node.

Study 1/Solution 1 (sol1)

In the **Model Builder** window, expand the **Results > Datasets** node, then click **Study 1/Solution 1 (sol1)**.

Selection

- 1 In the **Results** toolbar, click  **Attributes** and choose **Selection**.
- 2 In the **Settings** window for **Selection**, locate the **Geometric Entity Selection** section.
- 3 From the **Geometric entity level** list, choose **Domain**.
- 4 Select Domains 1, 3, 7, 8, 10, and 11 only.

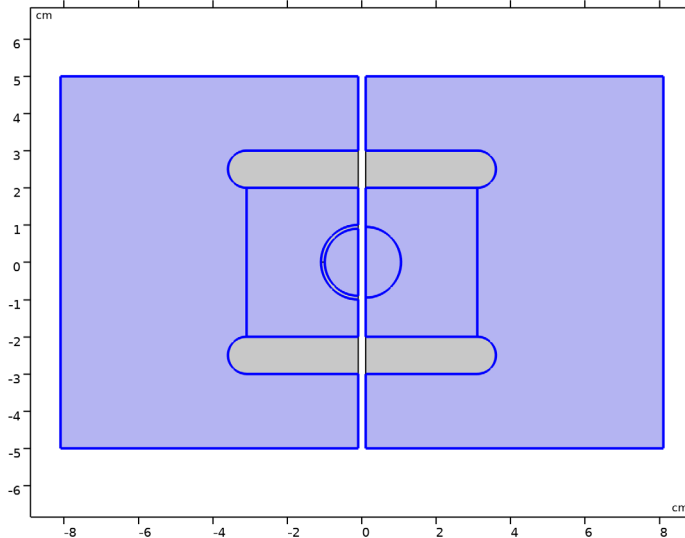

Create a custom plot to show the direction and norm of the electric field.

Electric Field (es)

- 1 In the **Results** toolbar, click  **2D Plot Group**.
- 2 In the **Settings** window for **2D Plot Group**, type **Electric Field (es)** in the **Label** text field.

Surface 1

- 1 Right-click **Electric Field (es)** and choose **Surface**.
- 2 In the **Settings** window for **Surface**, click **Replace Expression** in the upper-right corner of the **Expression** section. From the menu, choose **Component 1 (comp1) > Electrostatics > Electric > es.normE - Electric field norm - V/m**.
- 3 Locate the **Coloring and Style** section. From the **Color table** list, choose **GrayPrint**.
- 4 Clear the **Color legend** checkbox.
- 5 From the **Color table transformation** list, choose **Reverse**.

Electric Field (es)

Next, add a contour plot showing the electric potential.

Contour 1

- 1 In the **Model Builder** window, right-click **Electric Field (es)** and choose **Contour**.
- 2 In the **Settings** window for **Contour**, locate the **Levels** section.
- 3 In the **Total levels** text field, type 21.

Color Expression 1

- 1 Right-click **Contour 1** and choose **Color Expression**.
- 2 In the **Settings** window for **Color Expression**, click **Replace Expression** in the upper-right corner of the **Expression** section. From the menu, choose **Component 1 (comp1) > Electrostatics > Electric > es.normE - Electric field norm - V/m**.
- 3 Locate the **Coloring and Style** section. Clear the **Color legend** checkbox.

Electric Field (es)

Then, add a streamline plot of the electric field.

Streamline 1

- 1 In the **Model Builder** window, right-click **Electric Field (es)** and choose **Streamline**.
- 2 Select Boundaries 7, 30, 38, 39, 48, and 49 only.

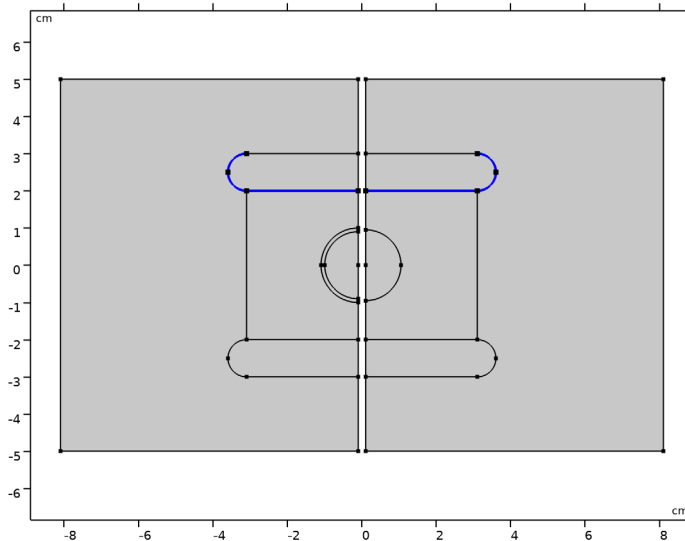

- 3 In the **Settings** window for **Streamline**, locate the **Streamline Positioning** section.

4 In the **Number** text field, type 30.

Color Expression 1

- 1 Right-click **Streamline 1** and choose **Color Expression**.
- 2 In the **Settings** window for **Color Expression**, click **Replace Expression** in the upper-right corner of the **Expression** section. From the menu, choose **Component 1 (comp1) > Electrostatics > Electric > es.normE - Electric field norm - V/m**.
- 3 Click the  **Zoom Extents** button in the **Graphics** toolbar.
Compare the plot with [Figure 2](#).

Finish the result analysis by evaluating the capacitance of the system.

Global Evaluation 1

- 1 In the **Results** toolbar, click  **Global Evaluation**.
- 2 In the **Settings** window for **Global Evaluation**, locate the **Expressions** section.
- 3 In the table, enter the following settings:

Expression	Unit	Description
es.Q0_1/V0	F	

- 4 Click  **Evaluate**.

Global Evaluation 2

- 1 In the **Results** toolbar, click  **Global Evaluation**.
- 2 In the **Settings** window for **Global Evaluation**, locate the **Expressions** section.
- 3 In the table, enter the following settings:

Expression	Unit	Description
es.Q0_2/V0	F	

- 4 Click  next to  **Evaluate**, then choose **Table 1 - Global Evaluation 1**.

The capacitance should be about 120 pF in both cases.