



Model created in COMSOL Multiphysics 6.4

Submarine Cable 4 – Inductive Effects

Introduction

Results from the *Capacitive Effects* and *Bonding Capacitive* tutorials (the previous tutorials in this series) show there is only a weak coupling between the inductive and capacitive phenomena in the cable. In addition to this, research [1, 2] suggests 2D and 2.5D inductive models are able to provide a good approximation of the cable's lumped quantities, and at only a fraction of the computational cost (as compared to long 3D twist models).

This justifies a 2D/2.5D inductive model that includes out-of-plane currents only. The model demonstrates methods suitable to approximate the armor twist, as well as certain *milliken conductor* designs. It serves as a basis and a reference for the *Thermal Effects* and the *Inductive Effects 3D* tutorials (chapters 6 and 8). Verification is included; the results are compared to the cable's official specifications.

Model Definition

The geometry is the same as the one used in the *Capacitive Effects* tutorial; see [Figure 1](#). It describes a detailed cross section (as built in the *Introduction* tutorial). A large number of material properties is included for the metals, the polymers, and the sea bed.

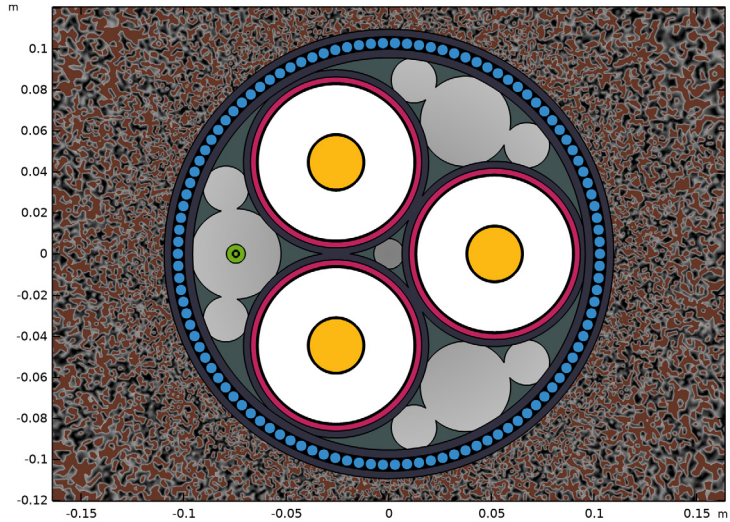

Figure 1: The cable's cross section, including the three phases (yellow), screens (red), the XLPE (white), the armor (blue), and the fiber (green).

THEORETICAL BASIS

The model solves Maxwell–Ampère’s law in the frequency domain, and in 2D, using the out-of-plane magnetic vector potential \mathbf{A} as a dependent variable. The underlying theory is discussed using the differential form, together with the SI unit system.

When solving, all four Maxwell’s equations are either directly or indirectly involved, together with two field definitions (\mathbf{E} and \mathbf{B} in terms of \mathbf{A}) and three *constitutive relations* — the ones containing the material properties ϵ , σ , and μ :

Gauss’s Law:	$\nabla \cdot \mathbf{D} = \rho$	Faraday’s Law:	$\nabla \times \mathbf{E} = -j\omega\mathbf{B}$
Magnetic Gauss’s Law:	$\nabla \cdot \mathbf{B} = 0$	Maxwell–Ampère’s Law:	$\nabla \times \mathbf{H} = \mathbf{J} + j\omega\mathbf{D}$
Electric Field:	$\mathbf{E} = -j\omega\mathbf{A}$	Dielectric Properties:	$\mathbf{D} = \epsilon_0\epsilon_r\mathbf{E} = \epsilon\mathbf{E}$
		Conductive Properties:	$\mathbf{J} = \sigma\mathbf{E}$
Magnetic Flux Density:	$\mathbf{B} = \nabla \times \mathbf{A}$	Magnetic Properties:	$\mathbf{B} = \mu_0\mu_r\mathbf{H} = \mu\mathbf{H}$

Conservation of Current

Let us start with the notion that when current is not conserved, you get a build-up of charge. This is given by $\nabla \cdot \mathbf{J} = \partial\rho/\partial t$ in the time domain, and $\nabla \cdot \mathbf{J} = -j\omega\rho$ in the frequency domain. You can combine this with Gauss’s law; $\nabla \cdot \mathbf{D} = \rho$, to get a modified current conservation law:

$$\nabla \cdot (\mathbf{J} + j\omega\mathbf{D}) = 0. \quad (1)$$

For the time domain, this would be $\nabla \cdot (\mathbf{J} + \partial\mathbf{D}/\partial t) = 0$, or, when using the electric field:

$$\nabla \cdot (\mathbf{J} + \epsilon\partial\mathbf{E}/\partial t) = 0, \quad (2)$$

where the first constitutive relation; $\mathbf{D} = \epsilon_0\epsilon_r\mathbf{E} = \epsilon\mathbf{E}$ is used.

What this result shows is that a time-varying electric (displacement) field is just another kind of current density, the *displacement current density*. This seems reasonable. After all, if you picture a charging capacitor, you will see currents flowing from the terminals to the capacitor plates but not from one plate to the other (due to the insulating dielectric). If you stick to the conviction that current is conserved at all times, and in all places, the increasing electric field between the plates must therefore be some other kind of current.

You might have noticed this in the *Capacitive Effects* tutorial, where both the displacement and the conduction current density are plotted: In the insulators, the displacement current density is prominent; in the conductors, the conduction current density is prominent; and the sum of both is conserved at all times. This is why some textbooks include the displacement current in the definition of the current density:

$$\mathbf{J}' = \mathbf{J} + j\omega\mathbf{D} = \sigma\mathbf{E} + j\omega\epsilon\mathbf{E} = (\sigma + j\omega\epsilon)\mathbf{E}, \quad (3)$$

where the second constitutive relation; $\mathbf{J} = \sigma\mathbf{E}$ is used. This relation suggests $\omega\epsilon$ is some sort of imaginary “conductivity” — one that does not involve losses (in the time domain, this is less obvious). It also explains why some people tend to use a complex permittivity in order to model resistive effects in the frequency domain.

Maxwell–Ampère’s Law

The second part of our derivation starts with Maxwell–Ampère’s law; $\nabla \times \mathbf{H} = \mathbf{J}'$, which basically states there is a direct relation between the magnetic field \mathbf{H} that encircles a conductor and the current density \mathbf{J}' that runs through it¹ — in fact, the very definition of the Ampère is based on this. If you take the *divergence* of that, it results in something very convenient:

$$\nabla \cdot (\nabla \times \mathbf{H}) = \nabla \cdot \mathbf{J}' = \nabla \cdot (\mathbf{J} + j\omega\mathbf{D}) = 0. \quad (4)$$

This is true by definition: From basic vector calculus follows that the divergence of the curl of *any* vector field must always be zero. In other words, if you define the current density to be equal to the curl of \mathbf{H} , you get a current conservation law for free — there is no additional equation required to enforce this.

Gauss’s law and Maxwell–Ampère’s law have now been applied. If you add the third constitutive relation²; $\mathbf{B} = \mu_0\mu_r\mathbf{H} = \mu\mathbf{H}$, you end up with the following:

$$\nabla \times \mathbf{H} = \nabla \times (\mu^{-1}\mathbf{B}) = \mathbf{J}' = (\sigma + j\omega\epsilon)\mathbf{E}. \quad (5)$$

1. Notice that initially, James Clerk Maxwell did not include the displacement currents, leading to a law that is valid under stationary conditions only (known as Ampère’s circuital law). He added the displacement currents a couple of years later — at equation (112) in his 1861 paper “On Physical Lines of Force” — resulting in what is now referred to as “Maxwell–Ampère’s law” (or, less formally; “Ampère’s law”).

2. Since this model runs in the frequency domain, you are restricted to linear material properties. It is possible to approximate the effect of a nonlinear material though; using effective nonlinear magnetic curves. For more on this, check the *AC/DC Module User’s Guide*.

The Magnetic Vector Potential

Now consider a vector field \mathbf{A} , the *magnetic vector potential* in Vs/m (or Wb/m), whose curl is chosen to be equal to the magnetic flux density \mathbf{B} . That is; $\nabla \times \mathbf{A} = \mathbf{B}$. The magnetic vector potential is not a directly measurable field or anything, nor is it unique. Without any additional constraints there are many different fields \mathbf{A} that fulfill the requirement³ $\nabla \times \mathbf{A} = \mathbf{B}$.

A similar thing happens for the electric scalar potential V . Even for electrostatic conditions, there is no such thing as an absolute (unique) electric potential: The potential is always measured with respect to some arbitrary reference (ground). What matters is the potential *difference*, or the potential *gradient*. The same goes for the magnetic vector potential. Using this relation between \mathbf{A} and \mathbf{B} , and taking the divergence once again, you get:

$$\nabla \cdot (\nabla \times \mathbf{A}) = \nabla \cdot \mathbf{B} = 0. \quad (6)$$

So if you define \mathbf{B} in terms of \mathbf{A} ; $\mathbf{B} = \nabla \times \mathbf{A}$, you get magnetic flux conservation (Gauss's law for magnetism) for free. This is for the exact same reason that you got current conservation for free.

Faraday's Law and the Final Partial Differential Equation

If you now substitute this definition of \mathbf{B} in Maxwell-Faraday's equation of electromagnetic induction; $\nabla \times \mathbf{E} = -j\omega\mathbf{B}$, you get:

$$\nabla \times \mathbf{E} = -j\omega(\nabla \times \mathbf{A}) = \nabla \times (-j\omega\mathbf{A}). \quad (7)$$

This gives you the last piece of the puzzle⁴: $\mathbf{E} = -j\omega\mathbf{A}$. Now, both \mathbf{B} and \mathbf{E} can be expressed in terms of \mathbf{A} . If you substitute this result in [Equation 5](#), you will find:

$$\nabla \times (\mu^{-1}\nabla \times \mathbf{A}) = (\sigma + j\omega\epsilon)(-j\omega\mathbf{A}). \quad (8)$$

Finally, if you swap about some terms and put everything on the left-hand side, you get the following *2D partial differential equation* for the dependent variable \mathbf{A} :

$$-\omega^2\epsilon\mathbf{A} + j\omega\sigma\mathbf{A} + \nabla \times (\mu^{-1}\nabla \times \mathbf{A}) = 0. \quad (9)$$

Due to the double curl, this is known as a curl-curl-type equation. The Magnetic Fields interface uses this equation in the domains to determine the value of \mathbf{A} , and consequently, the value of all the fields derived from it: \mathbf{E} , \mathbf{D} , \mathbf{J} , \mathbf{B} , and \mathbf{H} .

3. This phenomenon leads to *gauge freedom*. For more info, see the *AC/DC Module User's Guide*.

4. Notice that, with the electric field being defined solely in terms of the magnetic vector potential, we have been excluding the electric scalar potential, that is; $V = 0$. This choice is known as the *Weyl* or *Hamiltonian* gauge. For more information about different gauges and *gauge fixing*, see the *AC/DC Module User's Guide*.

Notice that the direction of \mathbf{A} is the same as the direction of \mathbf{E} (and \mathbf{J} , assuming isotropic material properties). If only the out-of-plane component of the magnetic vector potential is included (setting the other components equal to zero), in-plane currents and electric fields are neglected — considering the results seen in this tutorial series so far, this seems justified. Consequently, the 2D model treated here only produces in-plane magnetic fields. Omitting the in-plane components of \mathbf{A} significantly simplifies and stabilizes the problem.

For the outer boundaries the default condition $\mathbf{n} \times \mathbf{A} = 0$ is used, that constrains \mathbf{A} in the direction of the surface normal. Therefore, \mathbf{B} will be perpendicular to the surface normal; the magnetic flux lines will flow along the surface. This is known as a *magnetic insulation* condition (in analogy to electric or thermal insulation). Since the surface normal of a boundary in a 2D model is in-plane, and since the magnetic vector potential is chosen to be out-of-plane only, in effect the value of \mathbf{A} is zero on all outer boundaries. This gives you a complete set of equations and therefore a unique solution.

In order to excite the system, either an external electric field \mathbf{E}_{ext} or an external current density \mathbf{J}_{ext} is applied in the cable's main conductors. This field comes from an outside source not included in the model, presumably a power plant or a wind farm.

MODELING APPROACH

The tutorial starts with the basics; by exciting a current in the phases (using a **Coil** feature). As a result, strong eddy currents start to flow in both the screens and the armor. This configuration is effectively the same as *solid bonding*⁵.

In an attempt to mimic the effects caused by the armor twist, the armor wires are electrically connected in series by means of a **Coil group**. In a third step, the coil features used to excite the phase currents, are set to **Homogenized multiturn**. This allows for investigating the case where the current in the central conductors is evenly distributed — due to the use of twisted, insulated strands (or *milliken conductors*).

The inductance per phase in mH/km is compared to the cable's official specifications. For the AC resistance per phase, in mΩ/km, the DC resistance is used as a frame of reference:

$$R_{\text{dc}} = \frac{1}{\sigma_{\text{cu}} A}, \quad (10)$$

where σ_{cu} and A refer to the copper conductivity and the total effective cross-sectional surface area of a phase respectively. The DC resistance serves as a lower bound for the AC resistance, that is; $R_{\text{ac}} = \eta R_{\text{dc}}$ with $\eta \geq 1$. It represents a condition where all losses due to parasitic inductive effects have been successfully eliminated.

5. For more information on bonding types, see the *Bonding Capacitive* and *Bonding Inductive* tutorials.

ON ARMOR TWIST AND 2.5D

The 2D model represents a plain extrusion. In practice the armor is twisted however, with a different pitch than the central conductors have (see the *Inductive Effects 3D* tutorial).

As a result, every armor wire will sense every side of the cable at some point along its length (cyclic even). The first armor wire shown in the cross section (Figure 1) will be the second one a bit farther down the cable; *they are indistinguishable*. Therefore, all wires will have to carry the same total longitudinal current. The effect can be mimicked by putting the armor wires in series, giving you what is known as a *2.5D model* [1, 2].

Note that the length of the cable cannot be used as an argument to expect variations in current here, as the cable is much shorter than the relevant wavelength:

$$\lambda = \frac{2\pi}{\omega\sqrt{LC}}, \quad (11)$$

where L and C refer to the cable's inductance and capacitance per unit length. This wavelength is about $2.5 \cdot 10^3$ km, while the cable is assumed to be 10 km.

ON COIL DOMAINS

The **Coil** feature plays a central role in this model. It is one of the most important features included in the **Magnetic Fields** interface (or the AC/DC Module for that matter). The feature can be used as an active or passive element; it allows you to excite the system and to determine lumped parameters like inductance or resistance. Furthermore, it allows you to connect active or passive elements in your model to one another, to an external circuit, or to other models⁶. The feature supports two common conductor models:

Single conductor and **Homogenized multiturn**.

Single Conductor Model

In case of the single conductor model, the domain behaves like a single (solid) conductor; currents are free to flow as dictated by Maxwell–Ampère's law. Excitation is done by means of an external electric field \mathbf{E}_{ext} . This external electric field is then combined with the induced electric field $\mathbf{E}_{\text{emf}} = -j\omega\mathbf{A}$ to form a total electric field, and the total electric field is used to drive the currents. When the conductor is large enough with respect to the skin depth, skin- and proximity effects will occur. This is natural behavior.

The skin- and proximity effects will redistribute the cross-sectional current density; the current accumulates at the surface. This current accumulation leads to an increase in losses — after all, part of the conductor is not optimally used. This is why, in practice, most coils use insulated wires (turns) that are *electrically thin* (thin with respect to the skin depth).

6. This is demonstrated in the *Bonding Inductive* tutorial.

To be able to carry enough current, the amount of turns is increased (as opposed to increasing the thickness of the turns). This leads to the term *multiturn*. Moreover, the turns are placed in series⁷, so each turn will carry the same amount of current. With the turns being too thin to be *electrically visible*, a seemingly homogeneous current density distribution is achieved in a predefined direction (the direction of the wire bundle).

Homogenized Multiturn Model

With the homogenized multiturn setting, the coil domain models a bundle of turns (multiturn coil) or strands (litz wire), as an *effective material* with strongly anisotropic electrical properties and a homogenized current density distribution: No current will flow unless the coil is connected to something, or short circuited. The obvious advantage of this approach, is that the individual wires do not have to be resolved by the geometry or the mesh. In both cases (single conductor and homogenized multiturn), lumped parameters are determined by integrating current densities and electric fields in the proper directions. The resulting currents and voltages are compared to derive properties like impedance, inductance, resistance, and more.

Coil Groups

The **Coil group** option is specifically for 2D. When enabled, the coil feature considers every connected cluster of domains in the feature selection a different instance of the same entity crossing the 2D plane multiple times. Say that you have two separate circles in your 2D model. If you add both to the selection of your coil domain with the coil group setting enabled, what you are modeling is the same coil that passes your 2D plane twice. A typical example is a 2D axisymmetric model with a number of circles representing different turns of the same helix as it revolves around its axis a number of times.

From an electrical viewpoint, this means the selected domains are connected in series. More advanced functionality is available in order to create combinations of parallel and series connections, and to reverse the current in certain domains (for more details, check the AC/DC module users guide).

7. Note that litz wires form an exception. In case of a litz wire, the different strands (or turns) are placed in parallel instead of series. A similar current for each strand is achieved by twisting the strands in such a fashion that each individual strand occupies every part of the total cross section at some point along the wire.

Results and Discussion

Initially, the cable is modeled as a plain extrusion (a plain 2D model). The currents in the armor are oscillating way above and below the zero point, with a magnitude that differs between armor wires; see [Figure 2](#). The armor losses are rather high: 7.6 kW/km.

The screen currents are not restricted either (due to the use of solid bonding⁸). The resulting loss is 13 kW/km for the three screens combined. The phase losses settle at 47 kW/km, and the AC resistance is 53 mΩ/km.

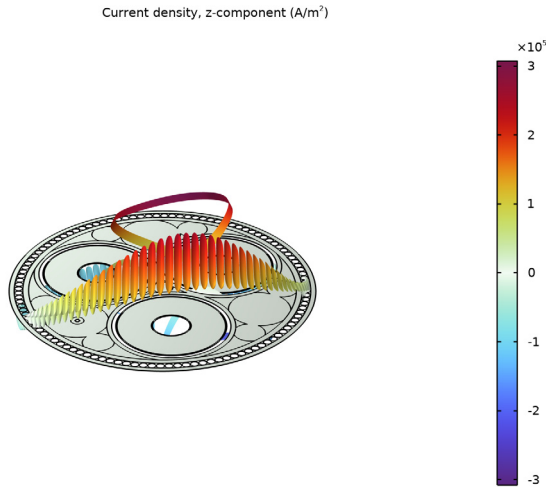

Figure 2: The real part of the out-of-plane current density distribution for the plain 2D configuration at phase $\varphi = 0^\circ$. The animated version is available as reference [4].

When the armor twist is applied (in the 2.5D model), the armor currents are suppressed; see [Figure 3](#). The armor losses go down (significantly; to 360 W/km), but at the same time, the inductance goes up; see [Table 1](#). The reasoning behind this is as follows: For the plain 2D model, the parasitic armor currents were able to produce their own magnetic fields, opposing the ones coming from the phases (as dictated by Lenz's law). Now that this effect is suppressed, the reluctance of the magnetic circuit has decreased. In effect, the ring of highly permeable armor wires starts to be have more like a *magnetic core*.

8. For more information on bonding types, see the *Bonding Capacitive* and *Bonding Inductive* tutorials.

This “magnetic core” causes the overall magnetic energy in the system to go up (and along with it; the inductance). Due to this waterbed effect the phase and screen losses go up, by about 170 W and 2.1 kW per kilometer respectively. The total losses go down however, by about 7%. This is reflected by a reduced AC resistance of 49 mΩ/km.

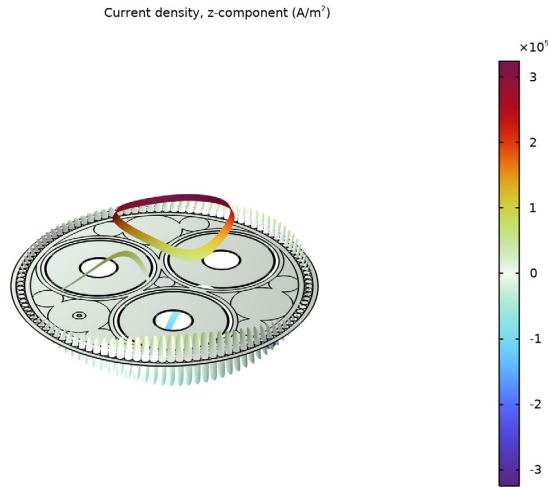

Figure 3: The real part of the out-of-plane current density distribution for the 2.5D configuration at phase $\varphi = 0^\circ$. The animated version is available as reference [6].

When compared to 3D twist models, it turns out neither the 2D nor the 2.5D model gives a perfect description. The 2D configuration is more accurate when it comes to the total losses and the resistance, while the 2.5D model is more accurate when it comes to the inductive properties — see the *Inductive Effects 3D* tutorial (and reference [1]).

TABLE 1: RESULTS FROM THE DIFFERENT TWIST CONFIGURATIONS COMPARED.

	Plain 2D Model	2.5D Model	2.5D + Milliken
Phase Losses (kW/km)	47	47	43
Screen Losses (kW/km)	13	15	16
Armor Losses (kW/km)	7.6	0.36	0.37
Phase AC Resistance (mΩ/km)	53	49	46
Rac/Rdc Ratio (-)	1.57	1.45	1.37
Phase Inductance (mH/km)	0.42	0.44	0.44

As a proof of concept, a means to model milliken conductors is explored. As long as the coil domains representing the phases are set to **Single conductor**, there is a skin effect and a proximity effect with a stronger current density near the cable's center; see [Figure 4](#).

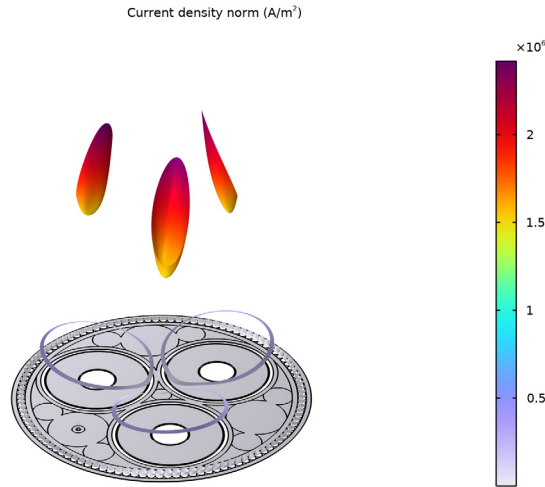

Figure 4: The current density norm (phase independent), with Single conductor setting used in the phases.

When the phases are set to **Homogenized multiturn**, however, their current density distribution is homogenized (see section [On Coil Domains](#)). As a result, the phase losses go down significantly, to 43 kW/km. With the parasitic currents removed from the main conductors, the overall magnetic energy in the system rises again and the screens and armor are subjected to stronger fields. The screen and armor losses go up, and settle at 16 kW/km and 370 W/km, respectively.

The 2.5D+milliken configuration gives a value of 46 mΩ/km for the AC resistance. The DC resistance (as given by [Equation 10](#)) evaluates to 34 mΩ/km. Note that the DC resistance serves as a lower bound; all attempts to suppress parasitic effects (to get the losses down), resulted in the AC resistance approaching the DC one. This is reflected by the AC/DC resistance ratio⁹ η , going down from 1.57, to 1.45, to 1.37.

Finally, when comparing the model to the 3D twist model from the *Inductive Effects 3D* tutorial (and the cable's specifications), the inductance gives a good match: 0.44 mH/km.

⁹. Together with the analytically determined DC resistance, this ratio is used in the *Thermal Effects* tutorial to provide an approximate value for the AC resistance.

ON ACCURACY

These results look very promising. Do not forget, however, that the 2D twist variants treated here, are all approximations. To start with, losses due to in-plane eddies have been neglected altogether. In a perfectly straight cable these would be zero, but real cables are twisted. To complicate matters further, the double twist allows the magnetic armor to provide an additional low-reluctance path for the field lines — one that 2D models cannot capture. For more on this, see the *Inductive Effects 3D* tutorial (chapter 8).

Secondly, the homogenized current distribution in the milliken conductor should be taken with a grain of salt. Putting insulation between the strands makes them thinner, twisting them makes them longer: inductive losses may go down, but the DC resistance will go up. The used material will typically be somewhere in-between a solid conductor and a perfectly stranded, twisted one. In practice you can assume the phases to behave like solid conductors, unless you have a good reason to believe otherwise (also considering the manufacturing costs). Lastly, in this tutorial thermal effects have not yet been considered. This topic will be treated in the *Thermal Effects* tutorial.

References

1. J.C. del-Pino-López, M. Hatlo, and P. Cruz-Romero, “On Simplified 3D Finite Element Simulations of Three-Core Armored Power Cables,” *Energies* 2018, 11, 3081.
2. J.J. Bremnes, G. Evenset, R. Stølan, “Power Loss and Inductance of Steel Armoured Multi-Core Cables: Comparison of IEC Values with 2.5D FEA Results and Measurements,” (Cigré 2010).
3. Video file submarine_cable_z_animation_04_plain_2d_model, available for download at www.comsol.com/model/cable-tutorial-series-43431.
4. Video file submarine_cable_z_animation_05_plain_2d_model_b, available for download at www.comsol.com/model/cable-tutorial-series-43431.
5. Video file submarine_cable_z_animation_06_2.5d_model, available for download at www.comsol.com/model/cable-tutorial-series-43431.
6. Video file submarine_cable_z_animation_07_2.5d_model_b, available for download at www.comsol.com/model/cable-tutorial-series-43431.

Application Library path: ACDC_Module/Tutorials,_Cables/
submarine_cable_04_inductive_effects

Modeling Instructions

This tutorial will focus on inductive effects. The instructions on the following pages will help you to build, configure, solve and analyze the model. If anything seems out of order, please retrace your steps. The finalized model — available in the model's Application Libraries folder — can help you out. You can compare it directly to your current model by means of the **Compare** option in the **Developer** toolbar.

ROOT

The geometry, materials, and mesh have been prepared in the *Introduction* tutorial (chapter 1). They have been saved in the file `submarine_cable_01_introduction.mph`. You can start by opening this file and saving it under a new name.



Hint: if you are new to COMSOL Multiphysics, it is worthwhile to check out the Introduction tutorial first.

- 1 From the **File** menu, choose **Open**.
- 2 Browse to the model's Application Libraries folder and double-click the file `submarine_cable_01_introduction.mph`.
- 3 From the **File** menu, choose **Save As**.
- 4 Browse to a suitable folder and type the filename `submarine_cable_04_inductive_effects.mph`.

GLOBAL DEFINITIONS

Some parameters have been prepared for running the model, and verifying results afterward. You can load them from a file.

Electromagnetic Parameters

- 1 In the **Home** toolbar, click  **Parameters** and choose **Add > Parameters**.
- 2 In the **Settings** window for **Parameters**, type *Electromagnetic Parameters* in the **Label** text field.
- 3 Locate the **Parameters** section. Click  **Load from File**.
- 4 Browse to the model's Application Libraries folder and double-click the file `submarine_cable_c_elec_parameters.txt`.



The added parameters are the same as the ones used in the *Capacitive Effects* tutorial. f_0 , w_0 , V_0 and I_0 are pretty straightforward, where $1/\sqrt{3}$ and $\sqrt{2}$ convert from phase-to-phase to phase-to-ground, and from root mean square (RMS) to peak value respectively. $Scup$ to $Dsarm$ are some material properties and the skin depths derived from

those, and R_{con} , R_{pbs} are analytically determined DC resistances per phase. They are given by [Equation 10](#), and its screen equivalent.

The AC resistance will have to be determined by solving the model. Due to eddy currents, the AC resistance will be higher than the DC one (the DC resistance serves as a lower bound). Consequently, the ratio between the two, η , shows how successful losses due to parasitic inductive effects have been eliminated.

The last three; Ex_{lpe} , C_{pha} , and I_{cpha} , are related to capacitive effects. They have been investigated and discussed by the previous tutorials in this series. Now that the parameters are in place, proceed by adding some physics and a frequency domain study.

ADD PHYSICS

- 1 In the **Home** toolbar, click  **Add Physics** to open the **Add Physics** window.
- 2 Go to the **Add Physics** window.
- 3 In the tree, select **AC/DC** > **Electromagnetic Fields** > **Magnetic Fields (mf)**.
- 4 Click the **Add to Component 1** button in the window toolbar.
- 5 In the **Home** toolbar, click  **Add Physics** to close the **Add Physics** window.

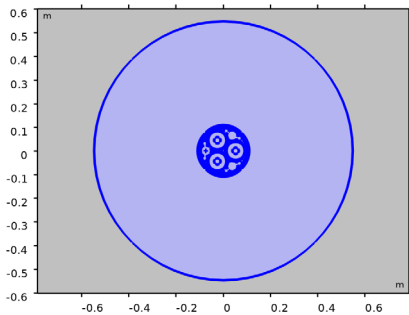

MAGNETIC FIELDS (MF)

- 1 In the **Settings** window for **Magnetic Fields**, locate the **Domain Selection** section.
- 2 From the **Selection** list, choose **Electromagnetic Domains**.
- 3 Click the  **Zoom to Selection** button in the **Graphics** toolbar.



For the electromagnetic analysis, the default domain condition is **Free Space**; it models air, or vacuum. You can consider it the empty canvas to draw on. In order to model solid domains, add an **Ampère's Law in Solids** feature. To get a better view, zoom in a couple of times.

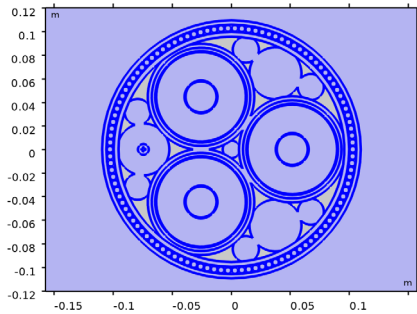

Ampère's Law in Solids I

- 1 In the **Physics** toolbar, click  **Domains** and choose **Ampère's Law in Solids**.
- 2 In the **Settings** window for **Ampère's Law in Solids**, locate the **Domain Selection** section.
- 3 From the **Selection** list, choose **Solid Domains**.
- 4 Click the  **Zoom In** button in the **Graphics** toolbar, twice.



Next, add a study.

ADD STUDY

- 1 In the **Home** toolbar, click  **Add Study** to open the **Add Study** window.
- 2 Go to the **Add Study** window.
- 3 Find the **Studies** subsection. In the **Select Study** tree, select **General Studies** > **Frequency Domain**.
- 4 Right-click and choose **Add Study**.
- 5 In the **Home** toolbar, click  **Add Study** to close the **Add Study** window.

STUDY 1

Step 1: Frequency Domain

- 1 In the **Settings** window for **Frequency Domain**, locate the **Study Settings** section.
- 2 In the **Frequencies** text field, type f_0 .

A minor modification to the solver configuration is done, so that the results are more compatible with those from the *Thermal Effects* tutorial — it will allow for comparing figures in the same table side-by-side.

Solution 1 (sol1)

- 1 In the **Study** toolbar, click  **Show Default Solver**.

- 2 In the **Model Builder** window, expand the **Study 1 > Solver Configurations > Solution 1 (sol1) > Stationary Solver 1** node.
- 3 Right-click **Study 1 > Solver Configurations > Solution 1 (sol1) > Stationary Solver 1 > Parametric 1** and choose **Delete**.

With the **Parametric** node included, the study will perform a frequency sweep containing one frequency only; f_0 . Without it, the study will just compute a single solution, without sweep. The difference is subtle but will affect the way results are stored in postprocessing.

MATERIALS

Now, you will see that COMSOL starts detecting missing material properties. The properties that should be added are listed in the following table. Please check all of them for the correct value, even the ones that are already filled in. *A quick option is to copy-paste the values directly from this *.pdf file to COMSOL.*

- 1 In the **Model Builder** window, under **Component 1 (comp1) > Materials**, check the following properties:

	Label	mur	sigma [S/m]	epsilon
mat6	Cross-linked polyethylene (XLPE)	1	1e-18[S/m]	Exlpe
mat11	Copper	Mcup	Ncon*Scup	1
mat12	Lead	Mpbs	Spbs	1
mat13	Galvanized steel	Marm	Sarm	1

Note that in the end, many material properties will be either ignored, overridden or proven to be insignificant. This is similar to what happens in the *Capacitive Effects* tutorial — although here, it is the conductors that will prevail (not the insulators).

Furthermore, for the copper in the central conductors the parameter N_{con} is used (the conductor packing density). N_{con} is the ratio between the conductor's true cross sectional surface area A_{con} , and the cross section used in the geometry; $\pi * (D_{con}/2)^2$. This ratio is below unity since these conductors are not actually solid but consist of a group of compacted strands, with some insulation or gaps in-between.

Instead of modeling the strands individually, we choose to have an *effective material* to represent both the copper and the gaps, having a conductivity of “ N_{con} times the conductivity of copper”. Note that this reasoning does not apply to coil domains using the **Homogenized multiturn** setting, as those have their own settings for the conductivity and the cross-sectional surface area. We will get back to that later.

MAGNETIC FIELDS (MF)

Now that the materials have been set and double-checked, let us have a look at the physics. With the default settings applied (out-of-plane vector potential only) the Magnetic Fields interface assumes zero in-plane currents (see section [Theoretical Basis](#)). When considering the charging currents, this assumption is justified (as seen in the *Capacitive Effects* tutorial). In-plane eddy currents are larger however — as seen in the *Inductive Effects 3D* tutorial — but still small enough to make this model a good approximation.

Start by applying currents to the three phases using a coil feature and compute your first solution (for more information on coil features, see the section [On Coil Domains](#)).

Phase 1

- 1 In the **Physics** toolbar, click  **Domains** and choose **Domain Coil**.
- 2 In the **Settings** window for **Domain Coil**, type Phase 1 in the **Label** text field.
- 3 Locate the **Domain Selection** section. From the **Selection** list, choose **Phase I**.

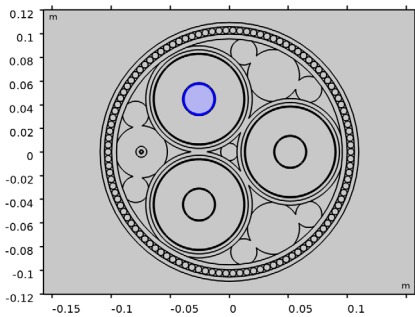

The settings window for the coil feature contains a lot of sections. For many of these, the default settings are sufficient. Collapse them to have a closer look at the important part; the **Coil** section.

- 4 Click to collapse the **Material Type** section, the **Coordinate System Selection** section, and the **Constitutive Relation** sections.

Next, proceed by setting the currents.

- 5 Locate the **Coil** section. In the I_{coil} text field, type I0.

Phase 2

- 1 In the **Physics** toolbar, click  **Domains** and choose **Domain Coil**.
- 2 In the **Settings** window for **Domain Coil**, type Phase 2 in the **Label** text field.

3 Locate the **Domain Selection** section. From the **Selection** list, choose **Phase 2**.

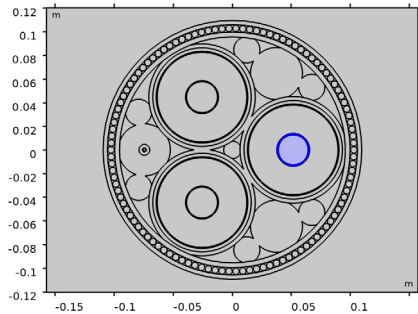

4 Locate the **Coil** section. In the I_{coil} text field, type $I_0 \cdot \exp(-120[\text{deg}] \cdot j)$.

Phase 3

1 In the **Physics** toolbar, click  **Domains** and choose **Domain Coil**.

2 In the **Settings** window for **Domain Coil**, type Phase 3 in the **Label** text field.

3 Locate the **Domain Selection** section. From the **Selection** list, choose **Phase 3**.

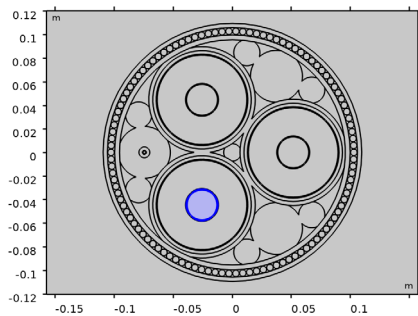

4 Locate the **Coil** section. In the I_{coil} text field, type $I_0 \cdot \exp(+120[\text{deg}] \cdot j)$.

Note that, since we are in the frequency domain, expressions like $\exp(-120[\text{deg}] \cdot j)$ or $\exp(-j \cdot 2 \cdot \pi / 3)$ may be used to set a 120° phase shift between the AC currents on the three main conductors.

So now you have added an Ampère's law feature with out-of-plane vector potential (the default), some material properties and a form of excitation. Together with the frequency domain study — *with the frequency set* — you should be free to go. Disable the default plots and click compute.

STUDY 1

1 In the **Model Builder** window, click **Study 1**.

- 2 In the **Settings** window for **Study**, locate the **Study Settings** section.
- 3 Clear the **Generate default plots** checkbox.
- 4 In the **Home** toolbar, click  **Compute**.

RESULTS

Magnetic Flux Density Norm (mf)

- 1 In the **Results** toolbar, click  **2D Plot Group**.
- 2 In the **Settings** window for **2D Plot Group**, type Magnetic Flux Density Norm (mf) in the **Label** text field.

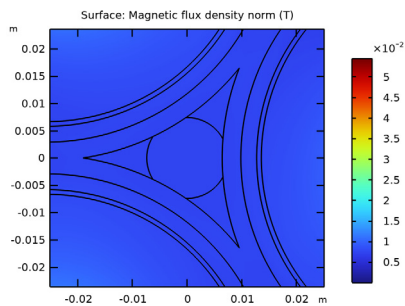

Surface 1

- 1 Right-click **Magnetic Flux Density Norm (mf)** and choose **Surface**.
- 2 In the **Magnetic Flux Density Norm (mf)** toolbar, click  **Plot**.
- 3 In the **Model Builder** window, click **Surface 1**.



The first thing to notice is that the **Magnetic Flux Density Norm** plot is zoomed-in quite a bit. This is because it is still locked to the camera settings used in the geometry and the mesh. Let us give it a separate view. Furthermore, you can fine-tune the surface plot settings to get a better picture of the field. The nonlinear color table transformation will allow you to get a higher resolution in the nonmagnetic domains.

Magnetic Flux Density Norm (mf)

- 1 In the **Model Builder** window, click **Magnetic Flux Density Norm (mf)**.
- 2 In the **Settings** window for **2D Plot Group**, locate the **Plot Settings** section.
- 3 From the **View** list, choose **New view**.
- 4 In the **Magnetic Flux Density Norm (mf)** toolbar, click  **Plot**.
- 5 Click the  **Zoom Extents** button in the **Graphics** toolbar.
- 6 Click the  **Zoom In** button in the **Graphics** toolbar, twice.

Surface 1

- 1 In the **Model Builder** window, click **Surface 1**.
- 2 In the **Settings** window for **Surface**, locate the **Coloring and Style** section.
- 3 From the **Color table** list, choose **Prism**.
- 4 From the **Color table transformation** list, choose **Nonlinear**.
- 5 Set the **Color calibration parameter** value to **-1.5**.
- 6 Click to expand the **Quality** section. From the **Evaluation settings** list, choose **Manual**.
- 7 From the **Resolution** list, choose **Fine**.
- 8 In the **Magnetic Flux Density Norm (mf)** toolbar, click  **Plot**.

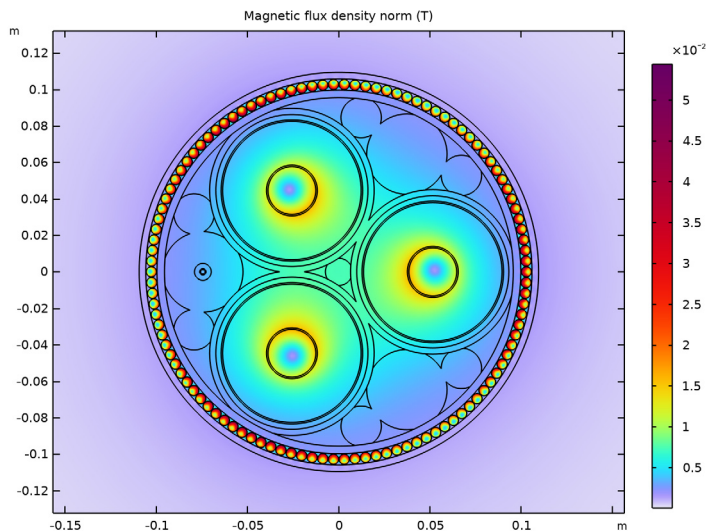

This plot shows the norm of the magnetic flux density. Since we are in the frequency domain, the magnetic flux density is a complex vector field. The corresponding norm is defined as $\|\mathbf{B}\| = \sqrt{(\mathbf{B} \cdot \mathbf{B}^*)} = (|B_x|^2 + |B_y|^2)^{1/2}$. Consequently, the plot looks three-fold symmetric and is phase independent.

Now, let us have a look at the current density norm.



Out of Plane Current Density (mf)

- 1 In the **Model Builder** window, right-click **Magnetic Flux Density Norm (mf)** and choose **Duplicate**.
- 2 In the **Settings** window for **2D Plot Group**, type Out of Plane Current Density (mf) in the **Label** text field.

- 3 Locate the **Plot Settings** section. From the **View** list, choose **New view**.

This new view is needed, as we want to decouple the camera settings of this plot from the previous one (we will get back to this).

Surface 1

- 1 In the **Model Builder** window, expand the **Out of Plane Current Density (mf)** node, then click **Surface 1**.
- 2 In the **Settings** window for **Surface**, click **Replace Expression** in the upper-right corner of the **Expression** section. From the menu, choose **Component 1 (comp1) > Magnetic Fields > Currents and charge > mf.normJ - Current density norm - A/m²**, (or just type `mf.normJ` in the **Expression** field).
- 3 Locate the **Coloring and Style** section. From the **Color table transformation** list, choose **None**.
- 4 In the **Out of Plane Current Density (mf)** toolbar, click  **Plot**.
- 5 Click the  **Zoom Extents** button in the **Graphics** toolbar.
- 6 Click the  **Zoom In** button in the **Graphics** toolbar, twice.

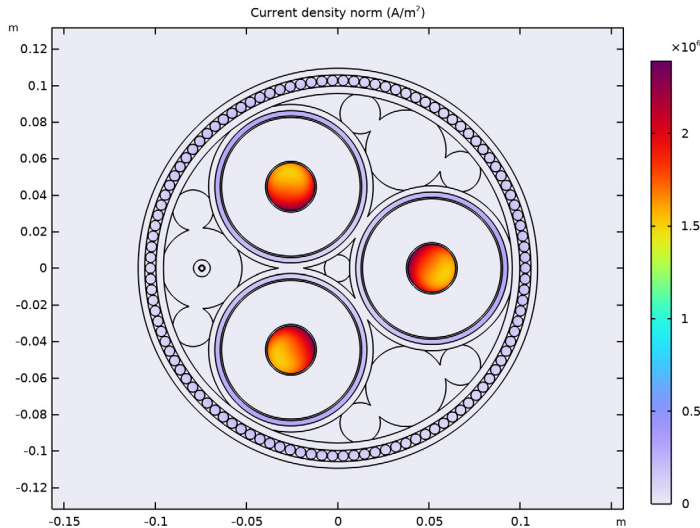



Here, you have switched from the variable `mf.normB`, to `mf.normJ`. For many quantities, predefined variables are available. You can find them using the buttons in the top-right corner of the **Expression** section, just above the text input field for the expression. There is some autocompletion functionality too (try pressing **Ctrl+Space** with the text input field in focus).

The current in the main conductors dominates. This current is desired (apart from the skin- and proximity effect). The parasitic currents in the screens and armor however, are not desired. Let us have a closer look at them by excluding the main conductors from the plot.

Study 1/Solution 1 (2) (sol1)

- 1 In the **Model Builder** window, expand the **Results > Datasets** node.
- 2 Right-click **Results > Datasets > Study 1/Solution 1 (sol1)** and choose **Duplicate**.

Selection

- 1 In the **Results** toolbar, click  **Attributes** and choose **Selection**.
- 2 In the **Settings** window for **Selection**, locate the **Geometric Entity Selection** section.
- 3 From the **Geometric entity level** list, choose **Domain**.
- 4 From the **Selection** list, choose **Cable Domains**.
- 5 Clear the selection for **Phase 1**, **Phase 2**, and **Phase 3** in the **Graphics** window.
- 6 Click the  **Zoom to Selection** button in the **Graphics** toolbar.

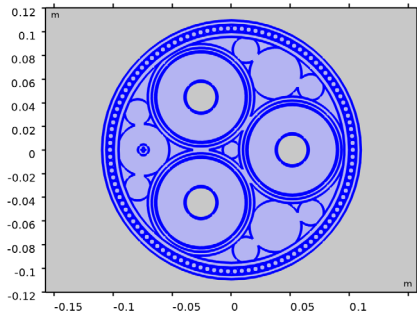

Out of Plane Current Density (mf)

- 1 In the **Model Builder** window, under **Results** click **Out of Plane Current Density (mf)**.
- 2 In the **Settings** window for **2D Plot Group**, locate the **Data** section.
- 3 From the **Dataset** list, choose **Study 1/Solution 1 (2) (sol1)**.
- 4 In the **Out of Plane Current Density (mf)** toolbar, click  **Plot**.

5 Click the  **Zoom Extents** button in the **Graphics** toolbar.

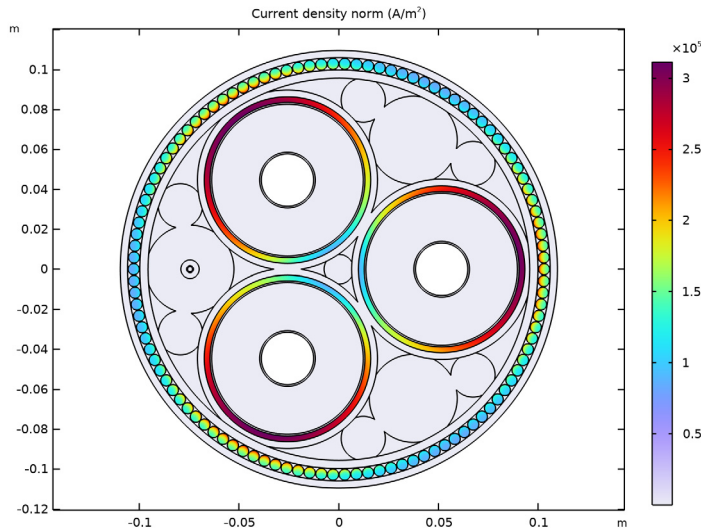

These are the screen and armor currents. The corresponding losses are of the resistive type (as opposed to magnetic or dielectric hysteresis losses). This kind of loss, also known as *Ohmic heating* or *Joule heating*, follows from Ohm's law. In the frequency domain, it is given by $|I|^2 R/2$, or, in differential form: $|\mathbf{J}|^2/(2\sigma)$, where σ is assumed to be a scalar quantity.

Notice that, as the sea bed surrounding the cable has been excluded from the solution, the size of the plotted cross section has become smaller. Consequently, this plot has a zoom setting that differs from the first one. It is for this reason, that we preferred to have separate camera settings for this plot. Proceed by investigating the corresponding losses.

Volumetric Loss Density (mf)

- 1 Right-click **Out of Plane Current Density (mf)** and choose **Duplicate**.
- 2 In the **Settings** window for **2D Plot Group**, type Volumetric Loss Density (mf) in the **Label** text field.

Surface I

- 1 In the **Model Builder** window, expand the **Volumetric Loss Density (mf)** node, then click **Surface I**.
- 2 In the **Settings** window for **Surface**, locate the **Expression** section.
- 3 In the **Expression** text field, type $mf.Qrh$.
- 4 Locate the **Coloring and Style** section. From the **Color table** list, choose **GrayBody**.

5 In the **Volumetric Loss Density (mf)** toolbar, click  **Plot**.

6 Click the  **Zoom Extents** button in the **Graphics** toolbar.

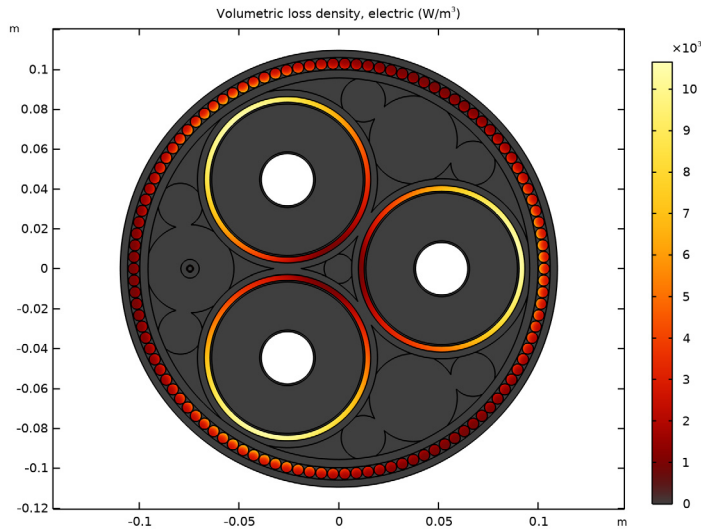

The plain 2D model gives a fair approximation of the cable’s resistive losses. Note that because of its complex permeability, the armor generates *magnetic hysteresis losses* too; those can be evaluated using the expression “mf.Qm1”. The total losses are given by $\text{mf} \cdot \text{Qh}$, which is the sum of both.

The magnitude and distribution of the losses will be off though, since the model does not include the cable’s twist. Several techniques are available to mimic a twist in 2D. Before implementing some of these however, let us investigate the phase dependency of the fields and currents by creating some nice animations.

Magnetic Flux Density Norm (mf)

For this, we make the **Magnetic Flux Density Norm** plot phase dependent using the norm of the instantaneous vector $\|\text{Re}(\mathbf{B})\| = (\text{Re}(B_x)^2 + \text{Re}(B_y)^2)^{1/2}$. As opposed to the norm used previously, this one is phase dependent: As B_x and B_y rotate in the complex plane, $\text{Re}(B_x)$ and $\text{Re}(B_y)$ will oscillate. A contour plot of A_z is added for the corresponding field lines.

Surface 1

1 In the **Model Builder** window, under **Results > Magnetic Flux Density Norm (mf)** click **Surface 1**.

2 In the **Settings** window for **Surface**, locate the **Expression** section.

3 In the **Expression** text field, type $\text{sqrt}(\text{real}(\text{mf} \cdot B_x)^2 + \text{real}(\text{mf} \cdot B_y)^2)$.

- 4 Select the **Description** checkbox. In the associated text field, type Magnetic flux density norm (instantaneous).

Contour 1

- 1 In the **Model Builder** window, right-click **Magnetic Flux Density Norm (mf)** and choose **Contour**.
- 2 In the **Settings** window for **Contour**, locate the **Expression** section.
- 3 In the **Expression** text field, type Az .
- 4 Click to expand the **Title** section. From the **Title type** list, choose **None**.
- 5 Locate the **Coloring and Style** section. From the **Coloring** list, choose **Uniform**.
- 6 From the **Color** list, choose **Black**.
- 7 Clear the **Color legend** checkbox.
- 8 Click to expand the **Quality** section. From the **Evaluation settings** list, choose **Manual**.
- 9 From the **Resolution** list, choose **Fine**.
- 10 In the **Magnetic Flux Density Norm (mf)** toolbar, click  **Plot**.

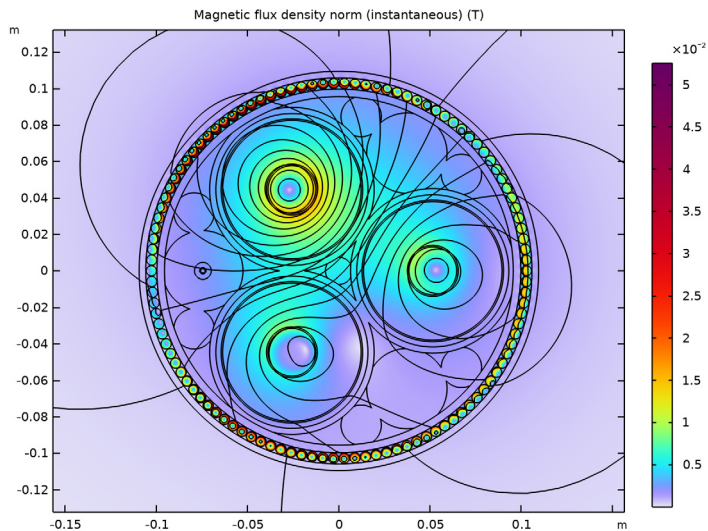

Animation 1

- 1 In the **Results** toolbar, click  **Animation** and choose **Player**.
- 2 In the **Settings** window for **Animation**, locate the **Animation Editing** section.
- 3 From the **Sequence type** list, choose **Dynamic data extension**.

4 Locate the **Frames** section. In the **Number of frames** text field, type 60.

5 Locate the **Playing** section. From the **Repeat** list, choose **Forever**.

6 Click the  **Play** button in the **Graphics** toolbar (see the animation from ref. [3]).

Hint: if you feel generating the animation takes too long on your machine, change the quality/resolution setting of the corresponding surface and contour plot from fine, to coarse.

Creating field lines by means of a contour plot of A_z is valid in this case, because of the relation $\mathbf{B} = \nabla \times \mathbf{A}$, combined with the fact that \mathbf{A} is strictly out of plane here. As opposed to the standard general-purpose streamline plots — the ones used for heat flux or fluid flow, for example — this contour plot gives you a physically accurate depiction of the magnetic flux lines. That is; the plot shows perfectly closed loops and the contour density is directly proportional to the instantaneous magnetic flux density. In case of streamlines it is only the *direction* that has meaning; the *density* should be taken with a grain of salt.

Furthermore, note that the act of plotting itself, takes the real part of A_z only. This is because plotting an actual complex 2D scalar field would require a 3D plot. In a way, that is what the animation does; it uses time as a third dimension to show the phase information contained in the solution.

7 Click the **Stop** button in the **Graphics** toolbar.

Out of Plane Current Density (mf)

As for the shape of the field lines, you might have noticed they bend when crossing the screen and the armor. This is an additional hint that the parasitic currents are significant. Let us see how the currents behave as a function of phase.

Surface I

1 In the **Model Builder** window, under **Results > Out of Plane Current Density (mf)** click **Surface I**.

2 In the **Settings** window for **Surface**, locate the **Expression** section.

3 In the **Expression** text field, type $\text{mf} \cdot J_z$.

(As opposed to $\text{mf} \cdot \text{norm}J$, this one is phase dependent).

4 Locate the **Coloring and Style** section. From the **Color table** list, choose **Dipole**.

5 From the **Scale** list, choose **Linear symmetric**.

Height Expression I



1 Right-click **Surface I** and choose **Height Expression**.

2 In the **Out of Plane Current Density (mf)** toolbar, click  **Plot**.

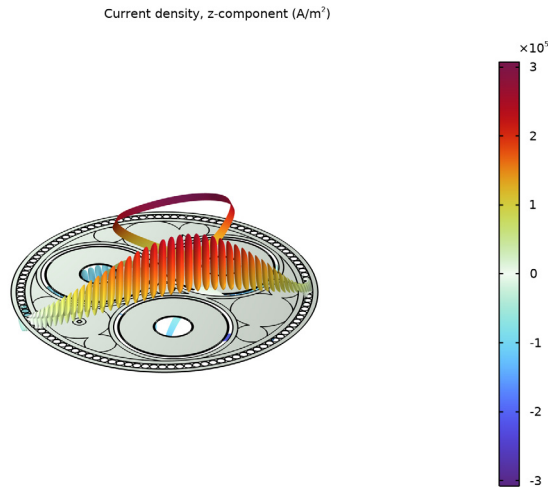
- 3 Click the  **Go to Default View** button in the **Graphics** toolbar.
- 4 In the **Model Builder** window, click **Height Expression 1**.



Animation 2

- 1 In the **Results** toolbar, click  **Animation** and choose **Player**.
- 2 In the **Settings** window for **Animation**, locate the **Scene** section.
- 3 From the **Subject** list, choose **Out of Plane Current Density (mf)**.
- 4 Locate the **Animation Editing** section. From the **Sequence type** list, choose **Dynamic data extension**.
- 5 Locate the **Frames** section. In the **Number of frames** text field, type 60.
- 6 Locate the **Playing** section. From the **Repeat** list, choose **Forever**.
- 7 Click the  **Play** button in the **Graphics** toolbar (see the animation from ref. [4]).

So the currents in the armor are oscillating way above and below the zero point, with a magnitude that differs between armor wires. In practice the armor is twisted however, with a different pitch than the central conductors have. As a result all wires will carry the same total longitudinal current. The effect can be mimicked by putting the armor wires in series (giving you a *2.5D model*, see section [On Armor Twist and 2.5D](#)).

Note that by using cross bonding (or single-point bonding), a similar effect can be achieved for the screens. This will be further investigated in the *Bonding Inductive*

tutorial. In the next part we will limit ourselves to the armor twist however, as cross bonding and single-point bonding are rarely used for submarine applications.

But first, let us quantify the total losses so we can make a good comparison later on.

- 8 Click the **Stop** button in the **Graphics** toolbar.

Phase Losses

- 1 In the **Results** toolbar, click 8.85×10^{-12} **More Derived Values** and choose **Integration > Surface Integration**.
- 2 In the **Settings** window for **Surface Integration**, type Phase Losses in the **Label** text field.
- 3 Locate the **Selection** section. From the **Selection** list, choose **Phases**.

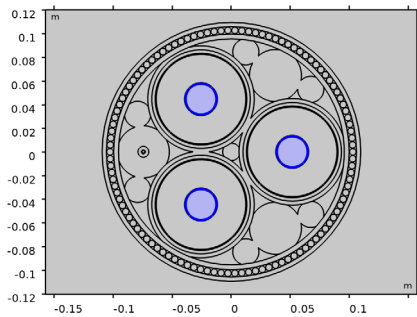

- 4 Locate the **Expressions** section. In the table, enter the following settings:

Expression	Unit	Description
mf.Qh	W/km	Phase losses (plain 2D model)

- 5 Click **= Evaluate**.

Screen Losses

- 1 In the **Results** toolbar, click 8.85×10^{-12} **More Derived Values** and choose **Integration > Surface Integration**.
- 2 In the **Settings** window for **Surface Integration**, type Screen Losses in the **Label** text field.

3 Locate the **Selection** section. From the **Selection** list, choose **Screens**.

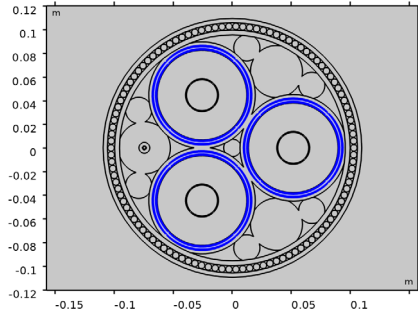

4 Locate the **Expressions** section. In the table, enter the following settings:

Expression	Unit	Description
mf.Qh	W/km	Screen losses (plain 2D model)

5 Click **Evaluate**.

Armor Losses

1 In the **Results** toolbar, click 8.85×10^{-12} **More Derived Values** and choose **Integration** > **Surface Integration**.

2 In the **Settings** window for **Surface Integration**, type **Armor Losses** in the **Label** text field.

3 Locate the **Selection** section. From the **Selection** list, choose **Cable Armor**.

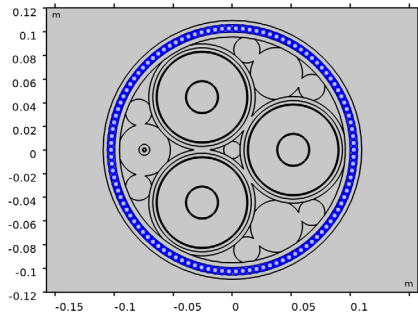

4 Locate the **Expressions** section. In the table, enter the following settings:

Expression	Unit	Description
mf.Qh	W/km	Armor losses (plain 2D model)

5 Click **Evaluate**.

TABLE 3

1 Go to the **Table 3** window.

The total losses per kilometer (both resistive and magnetic) should be about 47 kW, 13 kW, and 7.6 kW for the phases, screens, and armor respectively.

Furthermore, let us have a look at the lumped parameters. This is particularly useful when comparing these results with the ones from the *Thermal Effects* or the *Inductive Effects 3D* tutorial — or the cable’s official specifications and IEC 60287, for that matter.

RESULTS

Phase AC Resistance

1 In the **Results** toolbar, click  **Global Evaluation**.

2 In the **Settings** window for **Global Evaluation**, type Phase AC Resistance in the **Label** text field.

3 Locate the **Expressions** section. In the table, enter the following settings:

Expression	Unit	Description
$(mf.RCoil_1/1[m]+mf.RCoil_2/1[m]+mf.RCoil_3/1[m])/3$	mohm/km	Phase AC resistance (plain 2D model)

4 Click  **Evaluate**.

Phase Inductance

1 In the **Results** toolbar, click  **Global Evaluation**.

2 In the **Settings** window for **Global Evaluation**, type Phase Inductance in the **Label** text field.

3 Locate the **Expressions** section. In the table, enter the following settings:

Expression	Unit	Description
$(mf.LCoil_1/1[m]+mf.LCoil_2/1[m]+mf.LCoil_3/1[m])/3$	mH/km	Phase inductance (plain 2D model)

4 Click  **Evaluate**.

TABLE 5

1 Go to the **Table 5** window.

The phase AC resistance per kilometer for the plain 2D model should be about 53 mΩ. The inductance per kilometer should be about 0.42 mH. These figures will be affected when switching to a 2.5D model. Some of them will become “more accurate” when

compared to a full 3D twist model (or an actual measurement), some of them will be less accurate.

Neither the 2D nor the 2.5D model gives a perfect description. The 2D model should be more accurate when it comes to the total loss and the resistance, while the 2.5D model should be more accurate when it comes to the inductive properties — see the *Inductive Effects 3D* tutorial (and reference [1]).

Modeling Instructions — Armor Twist (2.5D Model)

MAGNETIC FIELDS (MF)

Proceed by applying a coil group to model the effect of the armor twist.

Cable Armor

- 1** In the **Physics** toolbar, click  **Domains** and choose **Domain Coil**.
- 2** In the **Settings** window for **Domain Coil**, type **Cable Armor** in the **Label** text field.
- 3** Locate the **Domain Selection** section. From the **Selection list**, choose **Cable Armor**.

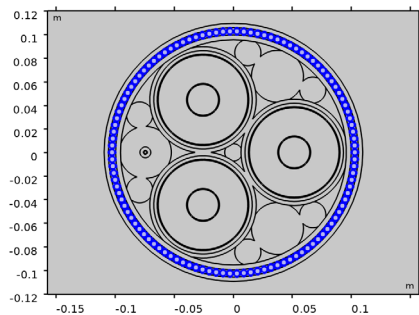

- 4** Locate the **Coil** section. Select the **Coil group** checkbox.
- 5** From the **Coil excitation** list, choose **Voltage**.
- 6** In the V_{coil} text field, type **0[V]**.

With the **Coil group** setting enabled, COMSOL considers the selected domains different instances of the same entity crossing the 2D plane multiple times. As a consequence, it puts the domains electrically in series (see section [On Coil Domains](#)). Additionally, you have set the excitation voltage to **0[V]**, effectively cross-circuiting the coil group. Now, the currents may flow freely as long as the total current is the same in all selected domains.

Hint: you can investigate the resulting behavior further by de-balancing the cable.

Let us compute.

STUDY 1

In the **Study** toolbar, click  **Compute**.

RESULTS

Magnetic Flux Density Norm (mf)

1 In the **Magnetic Flux Density Norm (mf)** toolbar, click  **Plot**.

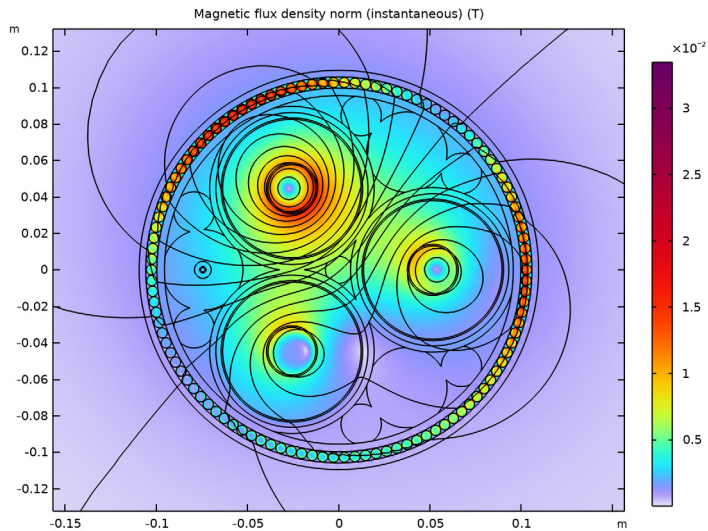

Notice how the field lines pass the armor more easily this time, and how the magnetic flux density distribution in the armor is more homogeneous now (for the corresponding animation, see reference [5]).

Out of Plane Current Density (mf)

1 In the **Model Builder** window, click **Out of Plane Current Density (mf)**.

2 In the **Out of Plane Current Density (mf)** toolbar, click  **Plot**.

- 3 Click the  **Go to Default View** button in the **Graphics** toolbar.

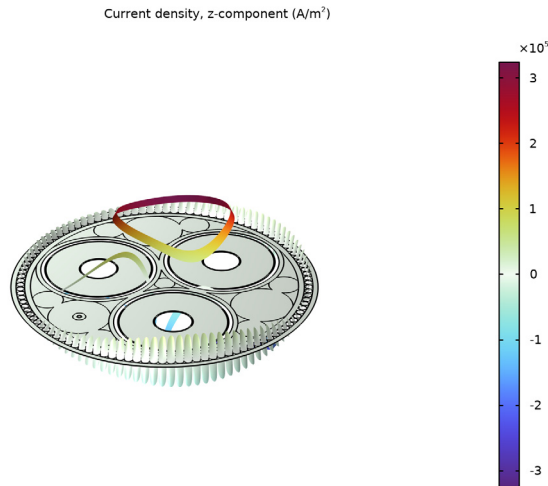

Animation 2

- 1 Click the  **Play** button in the **Graphics** toolbar (see the animation from ref. [6]).

The currents in the armor have been reduced significantly. Although they still oscillate locally inside the wire, the total net longitudinal current per armor wire is now zero (since this is a well-balanced cable). For those interested in different bonding types; *feel free to investigate what happens when you add an additional coil group to the screens.*

Since the coil group puts the domains in series (as opposed to forcing the total net current per domain to zero directly), the armor will show natural behavior in the sense that the losses will increase when the cable becomes de-balanced, *feel free to check this.*

Now, let us see how the armor twist affects the losses, the resistance, and the inductance.

- 2 In the **Model Builder** window, under **Results** > **Export** click **Animation 2**.
- 3 Click the **Stop** button in the **Graphics** toolbar.

Phase Losses

- 1 In the **Model Builder** window, under **Results** > **Derived Values** click **Phase Losses**.
- 2 In the **Settings** window for **Surface Integration**, locate the **Expressions** section.
- 3 In the table, update the description. Type Phase losses (2.5D model), that is; replace “plain 2D” with “2.5D”.
- 4 In the **Settings** window for **Surface Integration**, click **Evaluate**.

Screen Losses, Armor Losses, Phase AC Resistance, and Phase Inductance
Repeat these steps for **Screen Losses**, **Armor Losses**, **Phase AC Resistance**, and **Phase Inductance**.

TABLE

1 Go to the **Table** window.

The losses per kilometer should be about 47 kW, 15 kW, and 360 W for the phases, screens, and armor. As a response to the large reduction in losses for the armor, the phase- and screen losses went up (by about 170 W and 2.1 kW respectively). This waterbed effect is related to a redistribution of the magnetic energy.

The total loss in the cross section has been reduced by about 7%. This is reflected by a reduced AC resistance: 49 mΩ. The inductance increases slightly, to 0.44 mH, and by doing so, moves closer to the value given by the 3D model.

So the 2.5D model suggests the armor twist leads to an overall reduction in loss — although this should be taken with a grain of salt as some phenomena are not properly accounted for (as seen in the *Inductive Effects 3D* tutorial). In essence, the armor is forced to behave like some kind of *Litz wire*. Going further down this road, we can still gain another 3.5 kW per kilometer by modifying the main conductors.

Selection

1 In the **Model Builder** window, under **Results** > **Datasets** > **Study 1/Solution 1 (2) (sol1)** click **Selection**.



2 In the **Settings** window for **Selection**, locate the **Geometric Entity Selection** section.

3 From the **Selection** list, choose **Cable Domains**.

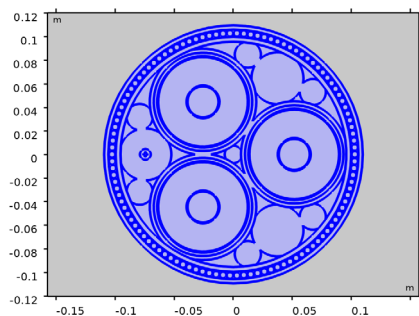
4 Click the  **Zoom to Selection** button in the **Graphics** toolbar.



Surface 1

- 1 In the **Model Builder** window, under **Results** > **Out of Plane Current Density (mf)** click **Surface 1**.
- 2 In the **Settings** window for **Surface**, locate the **Expression** section.
- 3 In the **Expression** text field, type `mf . normJ`.
- 4 Locate the **Coloring and Style** section. From the **Color table** list, choose **Prism**.
- 5 From the **Scale** list, choose **Linear**.
- 6 In the **Out of Plane Current Density (mf)** toolbar, click  **Plot**.
- 7 Click the  **Go to Default View** button in the **Graphics** toolbar.

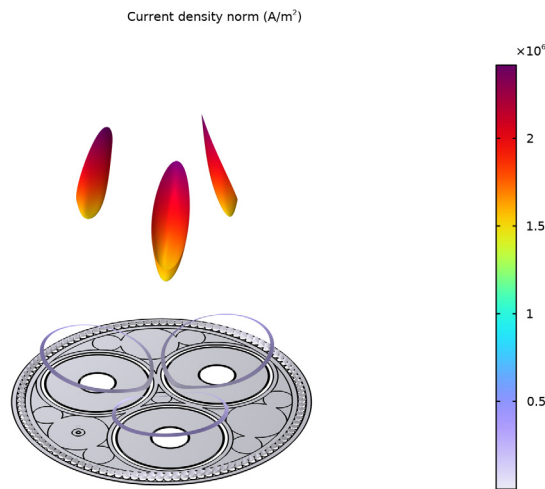

As you can see, the current in the main conductors is not homogeneous. There is a skin- and proximity effect, with a stronger current density near the cable's center. We have modeled solid conductors here (apart from the correction term; `Ncon`).

In practice however, the main conductors consist of twisted strands. Depending on the kind of insulation (if any) between the strands, the current density may be partially homogenized. For the sake of argument, let us assume this twisting technique works perfectly — *admittedly, not a realistic assumption for this particular kind of cable, but a useful exercise nonetheless.*

MAGNETIC FIELDS (MF)

Phase 1

- 1** In the **Model Builder** window, under **Component 1 (comp1) > Magnetic Fields (mf)** click **Phase 1**.
- 2** In the **Settings** window for **Domain Coil**, locate the **Coil** section.
- 3** From the **Conductor model** list, choose **Homogenized multiturn**.
- 4** Locate the **Homogenized Conductor** section. In the N text field, type 1.
- 5** In the σ text field, type Scup.
- 6** From the **Coil wire cross-section area** list, choose **User defined**.
- 7** In the a text field, type Acon.
- 8** Find the **High-frequency effective loss** subsection. Clear the **Include harmonic loss** checkbox.

Phase 2, Phase 3

Repeat these steps for **Phase 2**, and **Phase 3**.

You have used the **Homogenized multiturn** setting here. This is ideal for coils with multiple thin turns — or Litz wires with strands much thinner than the skin depth (this includes certain Milliken conductor designs). With this setting enabled, the turn or strand bundle will behave like a strongly anisotropic continuum with a homogenized cross-sectional current density distribution (see section [On Coil Domains](#)).

Since the strands are electrically connected in parallel, we set the number of turns to 1, and the wire cross section to Acon (the sum of all strands). Proceed by computing the final result.

STUDY 1

In the **Study** toolbar, click  **Compute**.

RESULTS

Out of Plane Current Density (mf)

- 1** In the **Model Builder** window, under **Results** click **Out of Plane Current Density (mf)**.
- 2** In the **Out of Plane Current Density (mf)** toolbar, click  **Plot**.

- 3 Click the  **Go to Default View** button in the **Graphics** toolbar.

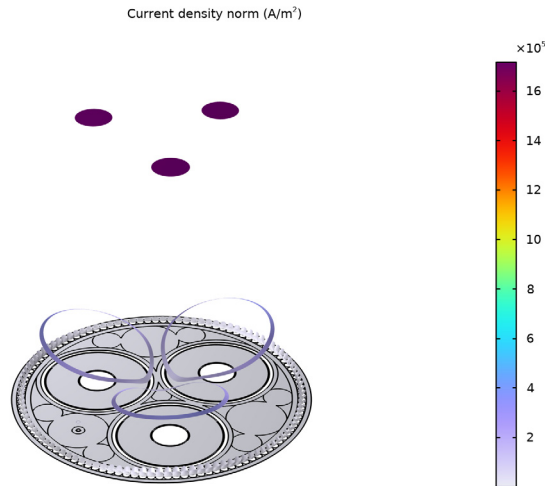

The current distribution is homogeneous now, with the total net current going through the main conductors still the same (I0 for each phase).

Phase Losses

- 1 In the **Model Builder** window, under **Results > Derived Values** click **Phase Losses**.
- 2 In the **Settings** window for **Surface Integration**, locate the **Expressions** section.
- 3 In the table, update the description. Type Phase losses (2.5D+Milliken), that is; replace “2.5D model” with “2.5D+Milliken”.
- 4 In the **Settings** window for **Surface Integration**, click **Evaluate**.

Screen Losses, Armor Losses

Repeat these steps for **Screen Losses** and **Armor Losses**.

TABLE

- 1 Go to the **Table** window.

The losses per kilometer should be about 43 kW, 16 kW, and 370 W for the phases, screens, and armor respectively.

Phase AC Resistance

- 1 In the **Model Builder** window, click **Phase AC Resistance**.
- 2 In the **Settings** window for **Global Evaluation**, locate the **Expressions** section.

3 In the table, enter the following settings:

Expression	Unit	Description
$(mf.RCoil_1/1[m]+mf.RCoil_2/1[m]+mf.RCoil_3/1[m])/3$	mohm/km	Phase AC resistance (2.5D+Milliken)
Rcon	mohm/km	Main conductor DC resistance per phase, at 20°C (analytic)

4 Click  **Evaluate**.

TABLE 4

1 Go to the **Table 4** window.

The phase resistance per kilometer should be about 46 mΩ and 34 mΩ for the AC- and DC resistance respectively. Notice that the AC resistance has moved fairly close to the DC one. As mentioned when introducing the parameters at the beginning of this tutorial, the DC resistance serves as a lower bound; all attempts done to get the losses down, resulted in the AC resistance approaching the DC one, *feel free to verify this*.

RESULTS

Phase Inductance

1 In the **Model Builder** window, under **Results > Derived Values** click **Phase Inductance**.

2 In the **Settings** window for **Global Evaluation**, locate the **Expressions** section.

3 In the table, update the description. Type Phase inductance (2.5D+Milliken), that is; replace “2.5D model” with “2.5D+Milliken”.

4 In the **Settings** window for **Global Evaluation**, click  **Evaluate**.

TABLE 5

1 Go to the **Table 5** window.

The inductance per kilometer should be about 0.44 mH. This is close to the official specifications and the 3D models, so this configuration seems to give a pretty accurate insight in the cable’s inductive performance.

Although these results look very promising, there are a couple of loose ends, still. The homogenized current in the central conductors is one of many possible approximations, and so is the solid conductor with conductivity $N_{con} * Scup$ (see section [On Accuracy](#)). Some might point out the current in the fiber’s armor should be put to zero, although the corresponding losses are negligible. Furthermore, we have the charging currents flowing

through the screens, resulting in some additional losses (about 0.38 kW per phase, as determined in the *Bonding Capacitive* tutorial).

More significant however, is the effect of *heat*. Thermal effects give rise to an increased resistivity and consequently, increased losses. The cable you have modeled here is 20°C, whereas any real cable would operate at a temperature of about 80 to 90°C. The sixth tutorial in this series will include a detailed thermal analysis.

You have now completed this tutorial, subsequent tutorials will refer to the resulting file as `submarine_cable_04_inductive_effects.mph`. The next tutorial in this series will investigate bonding types from an inductive viewpoint.

From the **File** menu, choose **Save**.