



Model created in COMSOL Multiphysics 6.4

# Static Field Modeling of a Halbach Rotor

## Introduction

---

This example presents the static-field modeling of a flux-focusing magnetic rotor using permanent magnets, a magnetic rotor also known as a Halbach rotor. The use of permanent magnets in rotatory devices such as motors, generators, and magnetic gears is increasing due to their no-contact, frictionless operation. This model illustrates how to calculate and change the magnetic field of a Halbach rotor in 3D by changing the number of permanent magnet segments and the number of pole-pairs.

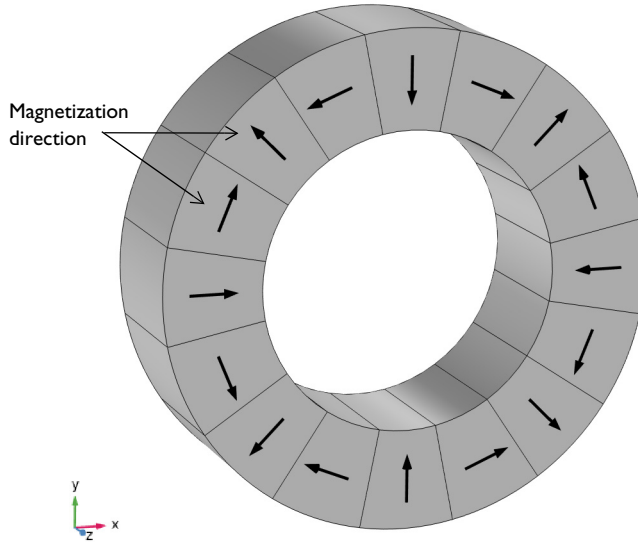

Figure 1: Illustration of a 16-segments, 4-pole pair Halbach rotor.

## Model Definition

---

Set up the problem in a 3D modeling space. The model consists of a parameterized number of permanent magnet pieces arranged with a varying number of pole pairs. [Figure 1](#) shows a 3D view of a 16-segments, 4-pole pair rotor with the magnetization direction of the magnets indicated. The black arrows show the radial and axial magnetization directions of the permanent magnets in the rotor. In this example, the permanent magnets are arranged in such a way that the magnetic flux density is minimized inside the rotor and maximized outside the rotor. The inner and outer rotor radii are 30 mm and 50 mm, respectively. The axial length of the rotor is 30 mm.

## Results and Discussion

A steady-state study analysis is performed to calculate the magnetic field of a 16-segments Halbach rotor. This is done in a parametric sweep over the additional angle for each permanent magnet's magnetization direction. The magnetic flux density for an 8-pole pair rotor is shown in Figure 2.

Figure 3 and Figure 4 illustrate the variations of the radial and azimuthal magnetic flux density as functions of rotor angle for the same rotor. The magnetic flux density is evaluated at a distance of 5 mm outside the rotor's outer radius and 5 mm inside the rotor's inside radius. Figure 5 shows the polar plot of the magnetic flux density norm at the same distances.

Another parametric sweep, this time over the number of segments, is then performed for an 8-pole pair rotor. The polar plot of the magnetic flux density norm for the 32-segments rotor is shown in Figure 6.

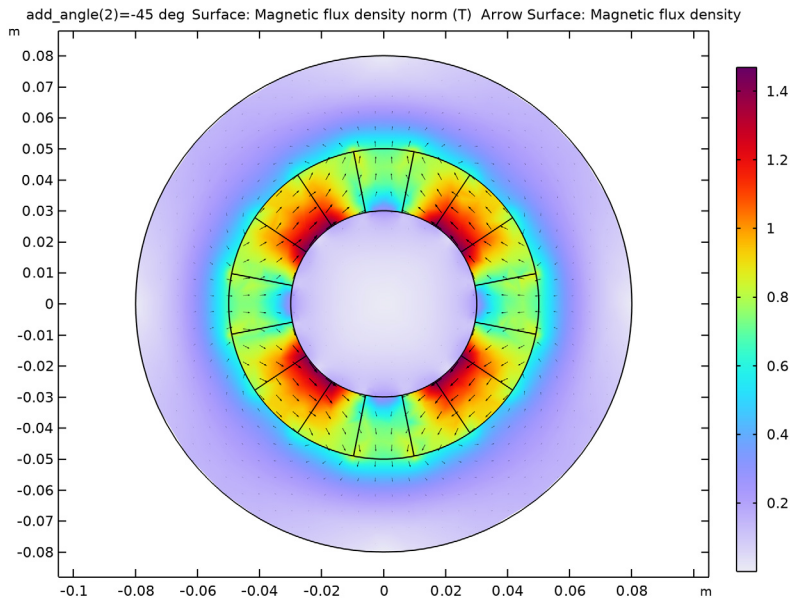

Figure 2: Magnetic flux density norm at the cross section of an 8-pole pair Halbach rotor (at  $z = 0$  mm).

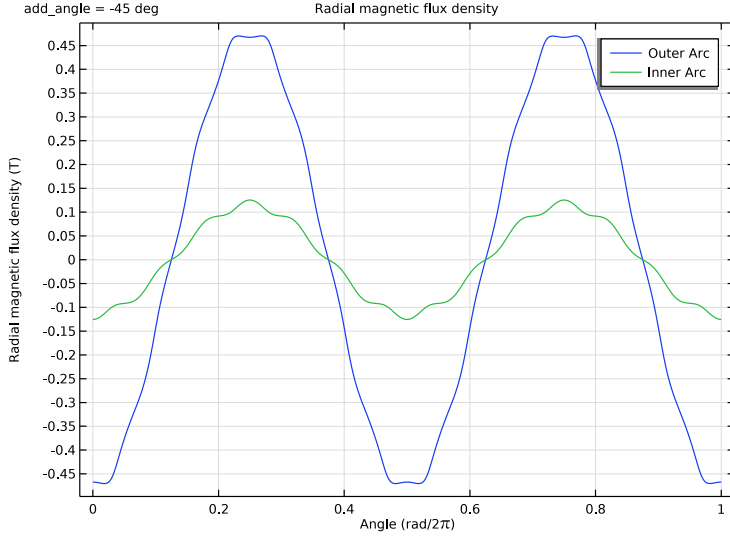

Figure 3: The radial magnetic flux density as a function of rotor angle measured at a distance of 5 mm inside and outside the rotor.

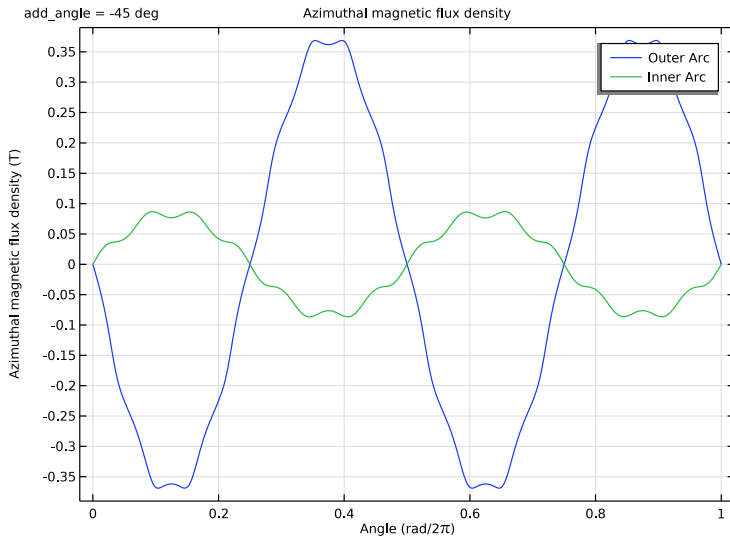

Figure 4: The azimuthal magnetic flux density as a function of rotor angle measured at a distance of 5 mm inside and outside the rotor.

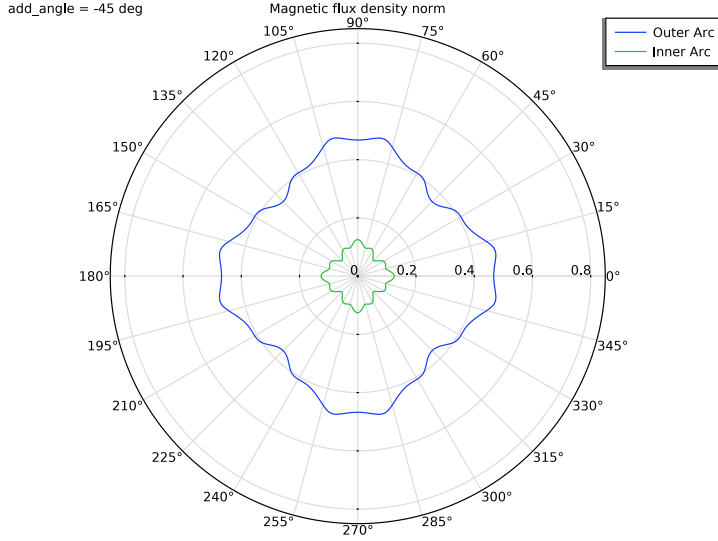

Figure 5: Polar plot of the magnetic flux density norm measured at a distance of 5 mm inside and outside a 16-segments rotor.

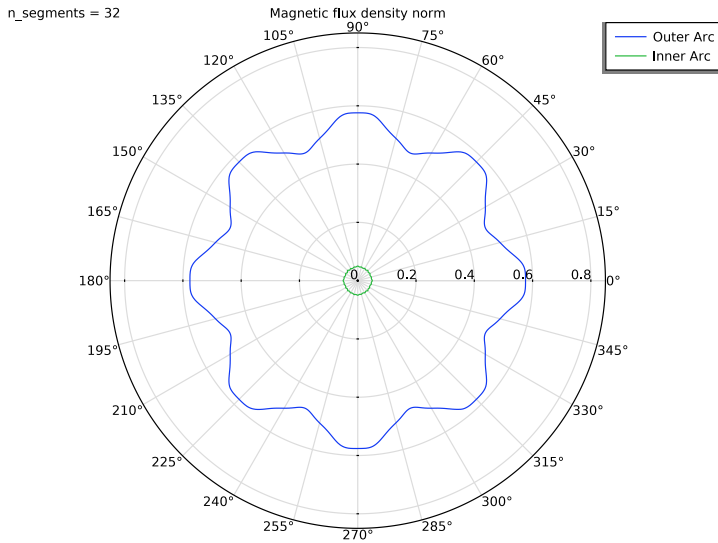

Figure 6: Polar plot of the magnetic flux density norm measured at a distance of 5 mm inside and outside a 32-segments rotor.

---

**Application Library path:** ACDC\_Module/Introductory\_Magnetostatics/  
static\_field\_halbach\_rotor\_3d

---

### *Modeling Instructions*



---

From the **File** menu, choose **New**.

#### **NEW**

In the **New** window, click  **Model Wizard**.

#### **MODEL WIZARD**

- 1 In the **Model Wizard** window, click  **3D**.
- 2 In the **Select Physics** tree, select **AC/DC > Magnetic Fields, No Currents > Magnetic Fields, No Currents (mfnc)**.
- 3 Click **Add**.
- 4 Click  **Study**.
- 5 In the **Select Study** tree, select **General Studies > Stationary**.
- 6 Click  **Done**.

#### **GLOBAL DEFINITIONS**

##### *Parameters I*

Load the model parameters from the  
static\_field\_halbach\_rotor\_3d\_parameters.txt file.

- 1 In the **Model Builder** window, under **Global Definitions** click **Parameters I**.
- 2 In the **Settings** window for **Parameters**, locate the **Parameters** section.
- 3 Click  **Load from File**.
- 4 Browse to the model's Application Libraries folder and double-click the file  
static\_field\_halbach\_rotor\_3d\_parameters.txt.

Most of these parameters govern the geometry of the rotor, `outer_analysis` and `inner_analysis` determine the radius of two circular arcs where the magnetic flux density will later be analyzed. The parameter `add_angle` is related to the physics and requires some more explanation. This parameter changes the relative magnetization

direction from one magnet segment in the rotor to the next. [Figure 1](#) shows the magnetization directions for `add_angle=-90[deg]`.

## GEOMETRY I

### *Work Plane 1 (wp1)*

- 1 In the **Model Builder** window, expand the **Component 1 (comp1)** > **Geometry 1** node.
- 2 Right-click **Geometry 1** and choose **Work Plane**.
- 3 In the **Settings** window for **Work Plane**, locate the **Plane Definition** section.
- 4 In the **z-coordinate** text field, type `-height/2`.

### *Work Plane 1 (wp1) > Plane Geometry*

In the **Model Builder** window, click **Plane Geometry**.



### *Work Plane 1 (wp1) > Circle 1 (c1)*

- 1 In the **Work Plane** toolbar, click  **Circle**.
- 2 In the **Settings** window for **Circle**, locate the **Size and Shape** section.
- 3 In the **Radius** text field, type `R0`.
- 4 In the **Sector angle** text field, type `alpha`.
- 5 Locate the **Rotation Angle** section. In the **Rotation** text field, type `-alpha/2`.

### *Work Plane 1 (wp1) > Circle 2 (c2)*



- 1 Right-click **Component 1 (comp1)** > **Geometry 1** > **Work Plane 1 (wp1)** > **Plane Geometry** > **Circle 1 (c1)** and choose **Duplicate**.
- 2 In the **Settings** window for **Circle**, locate the **Size and Shape** section.
- 3 In the **Radius** text field, type `Ri`.
- 4 Click  **Build Selected**.

### *Work Plane 1 (wp1) > Difference 1 (dif1)*

- 1 In the **Work Plane** toolbar, click  **Booleans and Partitions** and choose **Difference**.
- 2 Select the object **c1** only.
- 3 In the **Settings** window for **Difference**, locate the **Difference** section.
- 4 Click to select the  **Activate Selection** toggle button for **Objects to subtract**.
- 5 Select the object **c2** only.
- 6 Click  **Build Selected**.

### *Work Plane 1 (wp1) > Rotate 1 (rot1)*



- 1 In the **Work Plane** toolbar, click  **Transforms** and choose **Rotate**.

- 2 Select the object **dif1** only.
- 3 In the **Settings** window for **Rotate**, locate the **Rotation** section.
- 4 In the **Angle** text field, type range (alpha, alpha, 360).
- 5 Click  **Build Selected**.
- 6 Click the  **Zoom Extents** button in the **Graphics** toolbar.

### *Magnets*

- 1 In the **Model Builder** window, right-click **Geometry 1** and choose **Extrude**.
- 2 In the **Settings** window for **Extrude**, type **Magnets** in the **Label** text field.
- 3 Locate the **Distances** section. In the table, enter the following settings:

<b>Distances (m)</b>
height

- 4 Locate the **Selections of Resulting Entities** section. Select the **Resulting objects selection** checkbox.
- 5 Click  **Build Selected**.
- 6 Click the  **Zoom Extents** button in the **Graphics** toolbar.

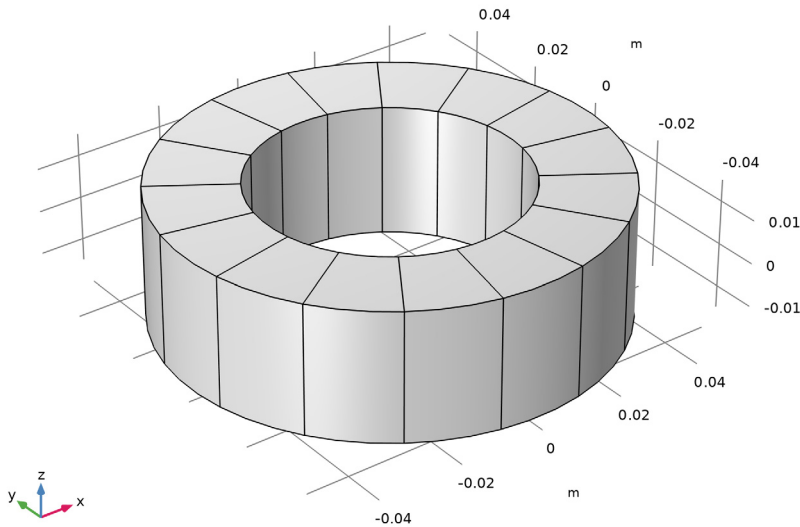

### *Cylinder 1 (cyl1)*

- 1 In the **Geometry** toolbar, click  **Cylinder**.
- 2 In the **Settings** window for **Cylinder**, locate the **Size and Shape** section.
- 3 In the **Radius** text field, type `r_system`.
- 4 In the **Height** text field, type `height_system`.
- 5 Locate the **Position** section. In the **z** text field, type `-height_system/2`.

### *Arcs*

- 1 In the **Geometry** toolbar, click  **Work Plane**.
- 2 In the **Settings** window for **Work Plane**, type **Arcs** in the **Label** text field.
- 3 Locate the **Selections of Resulting Entities** section. Select the **Resulting objects selection** checkbox.
- 4 From the **Show in physics** list, choose **Edge selection**.
- 5 Find the **Selections from plane geometry** subsection. Select the **Show in physics** checkbox.

### *Arcs (wp2) > Plane Geometry*

In the **Model Builder** window, click **Plane Geometry**.



### *Inner Arc*

- 1 In the **Work Plane** toolbar, click  **Circle**.
- 2 In the **Settings** window for **Circle**, type **Inner Arc** in the **Label** text field.
- 3 Locate the **Object Type** section. From the **Type** list, choose **Curve**.
- 4 Locate the **Size and Shape** section. In the **Radius** text field, type `inner_analysis`.
- 5 Locate the **Selections of Resulting Entities** section. Select the **Resulting objects selection** checkbox.
- 6 From the **Show in 3D** list, choose **Boundary selection**.

### *Outer Arc*

- 1 Right-click **Inner Arc** and choose **Duplicate**.
- 2 In the **Settings** window for **Circle**, type **Outer Arc** in the **Label** text field.
- 3 Locate the **Size and Shape** section. In the **Radius** text field, type `outer_analysis`.

### *Form Union (fin)*

- 1 In the **Geometry** toolbar, click  **Build All**.
- 2 Click the  **Zoom Extents** button in the **Graphics** toolbar.
- 3 Click the  **Wireframe Rendering** button in the **Graphics** toolbar.

- 4 In the **Model Builder** window, under **Component 1 (comp1) > Geometry 1** click **Form Union (fin)**.

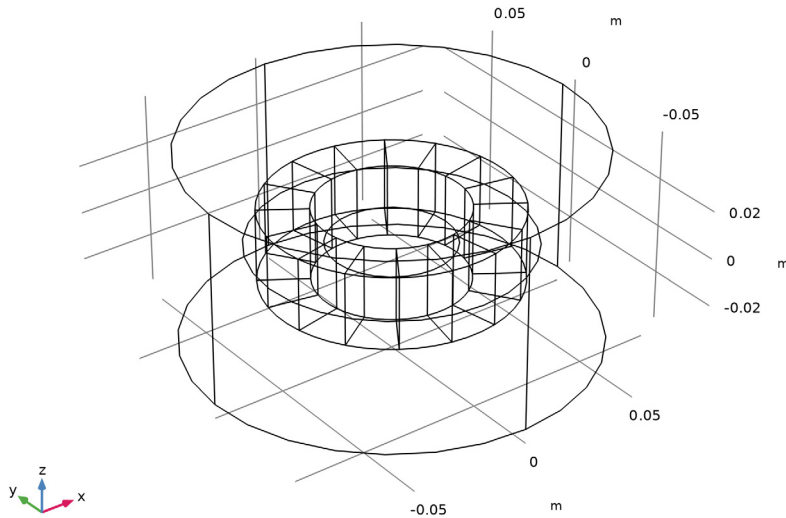

Create selections for the north and south boundaries of one magnet segment. This will later, by extension, help define all magnets' magnetization direction.

## DEFINITIONS

### *North Boundary*



- 1 In the **Definitions** toolbar, click  **Cylinder**.
- 2 In the **Settings** window for **Cylinder**, type North Boundary in the **Label** text field.
- 3 Locate the **Geometric Entity Level** section. From the **Level** list, choose **Boundary**.
- 4 Locate the **Size and Shape** section. In the **Outer radius** text field, type  $R_i$ .
- 5 In the **Inner radius** text field, type  $R_i$ .
- 6 In the **Start angle** text field, type  $-\alpha/2$ .
- 7 In the **End angle** text field, type  $\alpha/2$ .
- 8 Locate the **Output Entities** section. From the **Include entity if** list, choose **All vertices inside cylinder**.

### *South Boundary*

- 1 Right-click **North Boundary** and choose **Duplicate**.
- 2 In the **Settings** window for **Cylinder**, type South Boundary in the **Label** text field.
- 3 Locate the **Size and Shape** section. In the **Outer radius** text field, type  $R_o$ .
- 4 In the **Inner radius** text field, type  $R_o$ .

Next, create a cylindrical coordinate system and a **Vector Transform** feature to define variables for the radial and azimuthal magnetic flux densities.

### *Cylindrical System 2 (sys2)*

- 1 In the **Definitions** toolbar, click  **Coordinate Systems** and choose **Cylindrical System**.
- 2 Click the  **Show More Options** button in the **Model Builder** toolbar.
- 3 In the **Show More Options** dialog, select **General > Variable Utilities** in the tree.
- 4 In the tree, select the checkbox for the node **General > Variable Utilities**.
- 5 Click **OK**.

### *Vector Transform 1 (vectr1)*

- 1 In the **Definitions** toolbar, click  **Variable Utilities** and choose **Vector Transform**.
- 2 In the **Settings** window for **Vector Transform**, type  $B_{cy1}$  in the **Name** text field.
- 3 Locate the **Geometric Entity Selection** section. From the **Selection** list, choose **All domains**.
- 4 Click **Replace Expression** in the upper-right corner of the **Input** section. From the menu, choose **Component 1 (comp1) > Magnetic Fields, No Currents > Magnetic > Magnetic flux density > mfnc.B - Magnetic flux density - T**.
- 5 Locate the **Output** section. From the **Coordinate system** list, choose **Cylindrical System 2 (sys2)**.
- 6 Locate the **Transform Settings** section. From the **Transform as** list, choose **Flux vector**.

### *View 1*

Hide a few boundaries to view the results only in the inner part of the model domain.

### *Hide for Physics 1*

- 1 In the **Model Builder** window, right-click **View 1** and choose **Hide for Physics**.
- 2 In the **Settings** window for **Hide for Physics**, locate the **Geometric Entity Selection** section.
- 3 From the **Geometric entity level** list, choose **Boundary**.
- 4 Select Boundaries 1, 2, 4, and 49 only.

5 Click the  **Transparency** button in the **Graphics** toolbar.

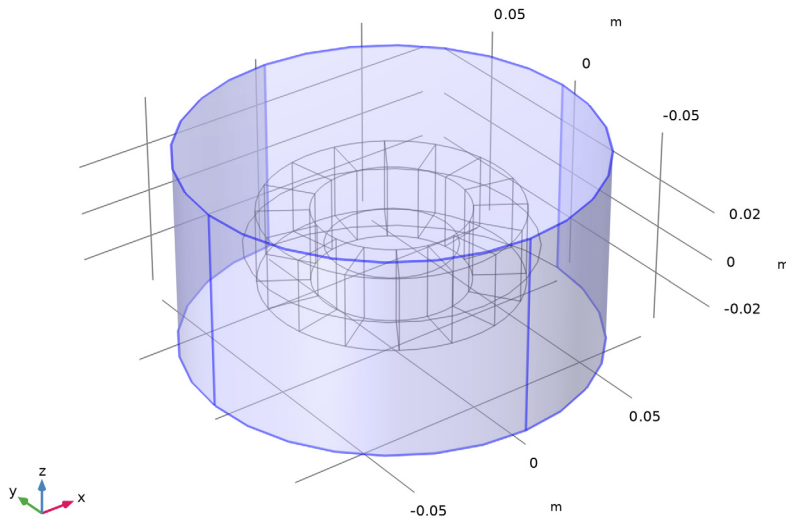

### **MAGNETIC FIELDS, NO CURRENTS (MFNC)**

Now, set up the physics interface

#### *Magnet 1*

- 1 In the **Physics** toolbar, click  **Domains** and choose **Magnet**.
- 2 In the **Settings** window for **Magnet**, locate the **Domain Selection** section.
- 3 From the **Selection** list, choose **Magnets**.
- 4 Locate the **Magnet** section. From the **Pattern type** list, choose **Circular pattern**.
- 5 From the **Type of periodicity** list, choose **User defined**.
- 6 In the  $\alpha$  text field, type `add_angle`.

#### *North 1*

- 1 In the **Model Builder** window, click **North 1**.
- 2 In the **Settings** window for **North**, locate the **Boundary Selection** section.
- 3 From the **Selection** list, choose **North Boundary**.

#### *South 1*

- 1 In the **Model Builder** window, click **South 1**.

- 2 In the **Settings** window for **South**, locate the **Boundary Selection** section.
- 3 From the **Selection** list, choose **South Boundary**.



The final addition to the physics interface is a point constraint for the magnetic scalar potential. Without this addition, there will be no unique solution which can cause problems in the solver.

#### *Zero Magnetic Scalar Potential I*

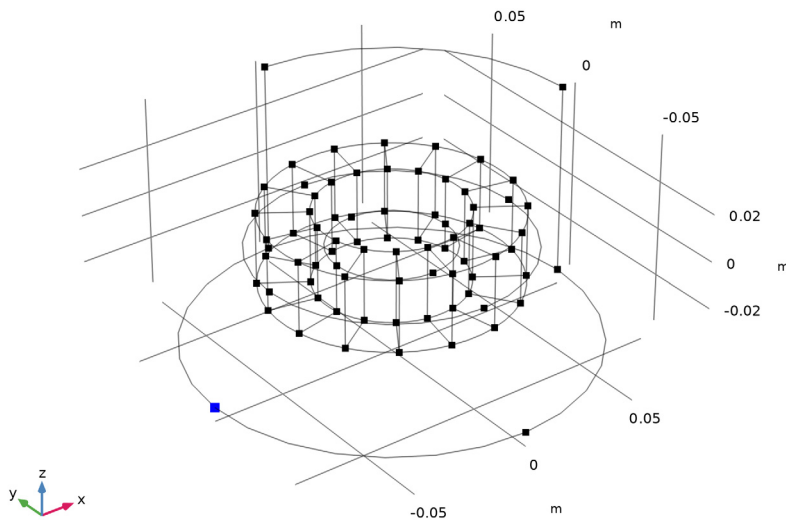
- 1 In the **Physics** toolbar, click  **Points** and choose **Zero Magnetic Scalar Potential**.
- 2 Select Point 1 only.



#### **ADD MATERIAL**

- 1 In the **Materials** toolbar, click  **Add Material** to open the **Add Material** window.
- 2 Go to the **Add Material** window.
- 3 In the tree, select **Built-in** > **Air**.
- 4 Click the **Add to Component** button in the window toolbar.
- 5 In the tree, select **AC/DC** > **Hard Magnetic Materials** > **Sintered NdFeB Grades (Chinese Standard)** > **N50 (Sintered NdFeB)**.
- 6 Click the **Add to Component** button in the window toolbar.
- 7 In the **Materials** toolbar, click  **Add Material** to close the **Add Material** window.

## MATERIALS

*N50 (Sintered NdFeB) (mat2)*

- 1 In the **Settings** window for **Material**, locate the **Geometric Entity Selection** section.
- 2 From the **Selection** list, choose **Magnets**.

## MESH 1

Next, the mesh will be constructed. Now it becomes clear why the inner and outer arcs were included in the geometry. These will be given very fine meshes to allow a highly resolved analysis of the magnetic field. First, however, specify the mesh size of the magnets.

*Size 1*

- 1 In the **Model Builder** window, under **Component 1 (comp1)** right-click **Mesh 1** and choose **Size**.
- 2 In the **Settings** window for **Size**, locate the **Geometric Entity Selection** section.
- 3 From the **Geometric entity level** list, choose **Domain**.
- 4 From the **Selection** list, choose **Magnets**.
- 5 Locate the **Element Size** section. From the **Predefined** list, choose **Finer**.

Specify a customized fine mesh on the curves where the magnetic flux density is to be evaluated. This helps to obtain a smooth curve for the magnetic flux density.

*Size 2*

- 1 In the **Model Builder** window, right-click **Mesh 1** and choose **Size**.
- 2 In the **Settings** window for **Size**, locate the **Geometric Entity Selection** section.
- 3 From the **Geometric entity level** list, choose **Edge**.
- 4 From the **Selection** list, choose **Arcs**.
- 5 Locate the **Element Size** section. Click the **Custom** button.
- 6 Locate the **Element Size Parameters** section.
- 7 Select the **Maximum element size** checkbox. In the associated text field, type 0.5[mm].

*Free Tetrahedral 1*

- 1 In the **Mesh** toolbar, click  **Free Tetrahedral**.

- 2 In the **Settings** window for **Free Tetrahedral**, click  **Build All**.  
Compare the mesh with the figure shown below.

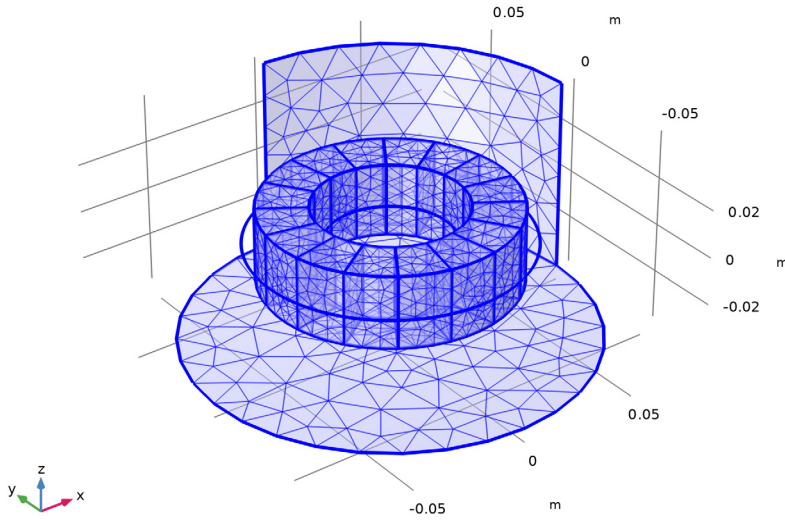



### STUDY 1 - ADDITIONAL ANGLE SWEEP

Now, create a **Parametric Sweep** for the stationary study. This will sweep over different values for the additional angle parameter to look at the resulting magnetic fields.

- 1 In the **Model Builder** window, click **Study 1**.
- 2 In the **Settings** window for **Study**, type Study 1 - Additional Angle Sweep in the **Label** text field.
- 3 Locate the **Study Settings** section. Clear the **Generate default plots** checkbox.

#### *Parametric Sweep*

- 1 In the **Study** toolbar, click  **Parametric Sweep**.
- 2 In the **Settings** window for **Parametric Sweep**, locate the **Study Settings** section.
- 3 Click  **Add**.

4 In the table, enter the following settings:

Parameter name	Parameter value list	Parameter unit
add_angle (Additional angle for magnetization pattern)	range (-90,45,90)	deg

5 In the **Study** toolbar, click  **Compute**.

## RESULTS

In the **Model Builder** window, expand the **Results** node.

Create a cut plane to analyze the magnetic field.

### *Cut Plane - Additional Angle Sweep*

- 1 In the **Model Builder** window, expand the **Results > Datasets** node.
- 2 Right-click **Results > Datasets** and choose **Cut Plane**.
- 3 In the **Settings** window for **Cut Plane**, type Cut Plane - Additional Angle Sweep in the **Label** text field.
- 4 Locate the **Data** section. From the **Dataset** list, choose **Study 1 - Additional Angle Sweep/ Parametric Solutions 1 (sol2)**.
- 5 Locate the **Plane Data** section. From the **Plane** list, choose **xy-planes**.

### *Magnetic Flux Density, Additional Angle Sweep*

- 1 In the **Results** toolbar, click  **2D Plot Group**.
- 2 In the **Settings** window for **2D Plot Group**, type Magnetic Flux Density, Additional Angle Sweep in the **Label** text field.

### *Surface 1*

- 1 In the **Magnetic Flux Density, Additional Angle Sweep** toolbar, click  **Surface**.
- 2 In the **Settings** window for **Surface**, locate the **Expression** section.
- 3 In the **Expression** text field, type `mfnc.normB`.
- 4 Locate the **Coloring and Style** section. From the **Color table** list, choose **Prism**.

### *Magnetic Flux Density, Additional Angle Sweep*

In the **Magnetic Flux Density, Additional Angle Sweep** toolbar, click  **Arrow Surface**.

### *Arrow Surface 1*

- 1 In the **Settings** window for **Arrow Surface**, locate the **Arrow Positioning** section.
- 2 Find the **x grid points** subsection. In the **Points** text field, type 30.
- 3 Find the **y grid points** subsection. In the **Points** text field, type 30.

4 Locate the **Coloring and Style** section. From the **Color** list, choose **Black**.

5 In the **Magnetic Flux Density, Additional Angle Sweep** toolbar, click  **Plot**.

Compare the plots corresponding to the different parameter values by clicking **Plot Previous** or **Plot Next**. Note how the magnetic flux density changes from being predominantly inside the rotor for positive values of `add_angle` to predominantly outside for negative values. Recreate the figure below for `add_angle=-45[deg]`.

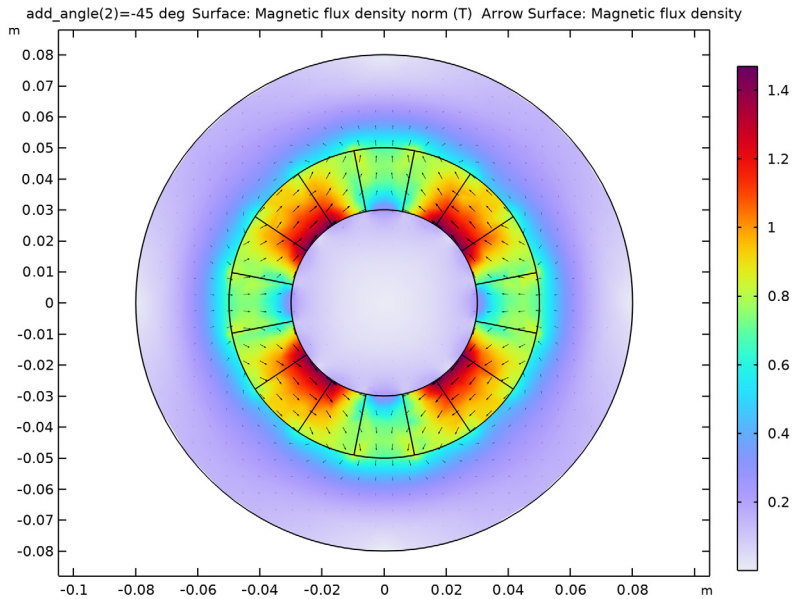

### Radial Magnetic Flux Density

1 In the **Results** toolbar, click  **ID Plot Group**.

2 In the **Settings** window for **ID Plot Group**, type Radial Magnetic Flux Density in the **Label** text field.

3 Locate the **Data** section. From the **Dataset** list, choose **Study 1 - Additional Angle Sweep/ Parametric Solutions 1 (sol2)**.

4 From the **Parameter selection (add\_angle)** list, choose **From list**.

5 In the **Parameter values (add\_angle (deg))** list box, select **-90**.

6 Click to expand the **Title** section. From the **Title type** list, choose **Manual**.

7 In the **Title** text area, type Radial magnetic flux density.

8 In the **Parameter indicator** text field, type `add_angle = eval(add_angle*180/pi) deg`.

- 9 Locate the **Plot Settings** section.
- 10 Select the **x-axis label** checkbox. In the associated text field, type  $\text{Angle (rad/2\pi)}$ .
- 11 Select the **y-axis label** checkbox. In the associated text field, type **Radial magnetic flux density (T)**.

#### *Outer Arc*

- 1 In the **Radial Magnetic Flux Density** toolbar, click  **Line Graph**.
- 2 In the **Settings** window for **Line Graph**, type **Outer Arc** in the **Label** text field.
- 3 Locate the **Selection** section. From the **Selection** list, choose **Outer Arc (Arcs)**.
- 4 Locate the **y-Axis Data** section. In the **Expression** text field, type  $B_{\text{cyl.vr}}$ .
- 5 Locate the **x-Axis Data** section. Select the **Normalize** checkbox.
- 6 Click to expand the **Legends** section. Select the **Show legends** checkbox.
- 7 Find the **Include** subsection. Select the **Label** checkbox.
- 8 Clear the **Solution** checkbox.

#### *Inner Arc*

- 1 Right-click **Outer Arc** and choose **Duplicate**.
- 2 In the **Settings** window for **Line Graph**, type **Inner Arc** in the **Label** text field.
- 3 Locate the **Selection** section. From the **Selection** list, choose **Inner Arc (Arcs)**.

4 In the **Radial Magnetic Flux Density** toolbar, click  **Plot**.

Note how the radial magnetic flux density changes on the two arcs for all parameter values by clicking **Plot Next** or **Plot Previous**. Compare the plot for `add_angle=-45[deg]` with the figure below.

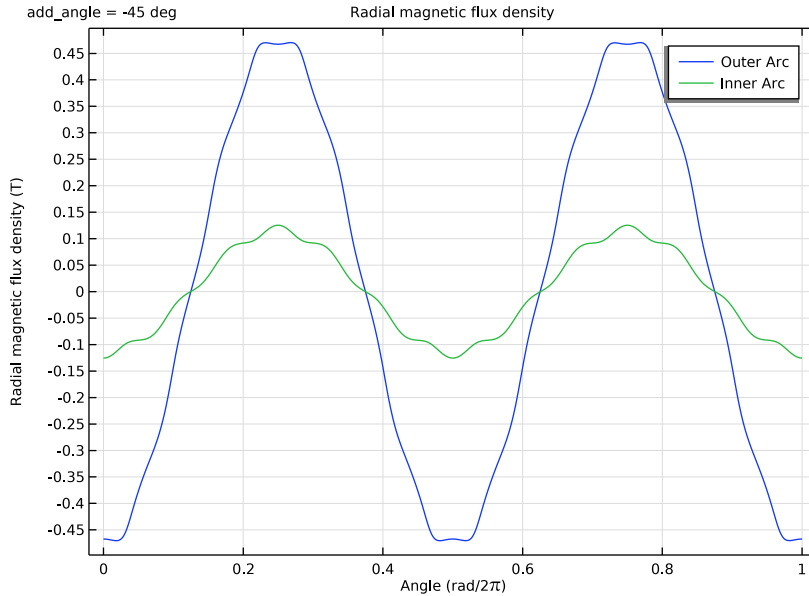

#### *Azimuthal Magnetic Flux Density*

- 1 In the **Results** toolbar, click  **ID Plot Group**.
- 2 In the **Settings** window for **ID Plot Group**, type Azimuthal Magnetic Flux Density in the **Label** text field.
- 3 Locate the **Data** section. From the **Dataset** list, choose **Study 1 - Additional Angle Sweep/ Parametric Solutions 1 (sol2)**.
- 4 From the **Parameter selection (add\_angle)** list, choose **From list**.
- 5 In the **Parameter values (add\_angle (deg))** list box, select **-90**.
- 6 Locate the **Title** section. From the **Title type** list, choose **Manual**.
- 7 In the **Title** text area, type Azimuthal magnetic flux density.
- 8 In the **Parameter indicator** text field, type `add_angle = eval(add_angle*180/pi)` deg.
- 9 Locate the **Plot Settings** section.

- 10 Select the **x-axis label** checkbox. In the associated text field, type  $\text{Angle (rad/2\pi)}$ .
- 11 Select the **y-axis label** checkbox. In the associated text field, type Azimuthal magnetic flux density (T).

#### *Outer Arc*

- 1 In the **Azimuthal Magnetic Flux Density** toolbar, click  **Line Graph**.
- 2 In the **Settings** window for **Line Graph**, type Outer Arc in the **Label** text field.
- 3 Locate the **Selection** section. From the **Selection** list, choose **Outer Arc (Arcs)**.
- 4 Locate the **y-Axis Data** section. In the **Expression** text field, type  $B_{\text{cyl.vphi}}$ .
- 5 Locate the **x-Axis Data** section. Select the **Normalize** checkbox.
- 6 Locate the **Legends** section. Select the **Show legends** checkbox.
- 7 Find the **Include** subsection. Select the **Label** checkbox.
- 8 Clear the **Solution** checkbox.

#### *Inner Arc*

- 1 Right-click **Outer Arc** and choose **Duplicate**.
- 2 In the **Settings** window for **Line Graph**, type Inner Arc in the **Label** text field.
- 3 Locate the **Selection** section. From the **Selection** list, choose **Inner Arc (Arcs)**.

4 In the **Azimuthal Magnetic Flux Density** toolbar, click  **Plot**.

Once again, compare the plots corresponding to the different parameter values by Clicking **Plot Next** or **Plot Previous**. Make sure the plot for `add_angle=-45[deg]` looks like the figure below.

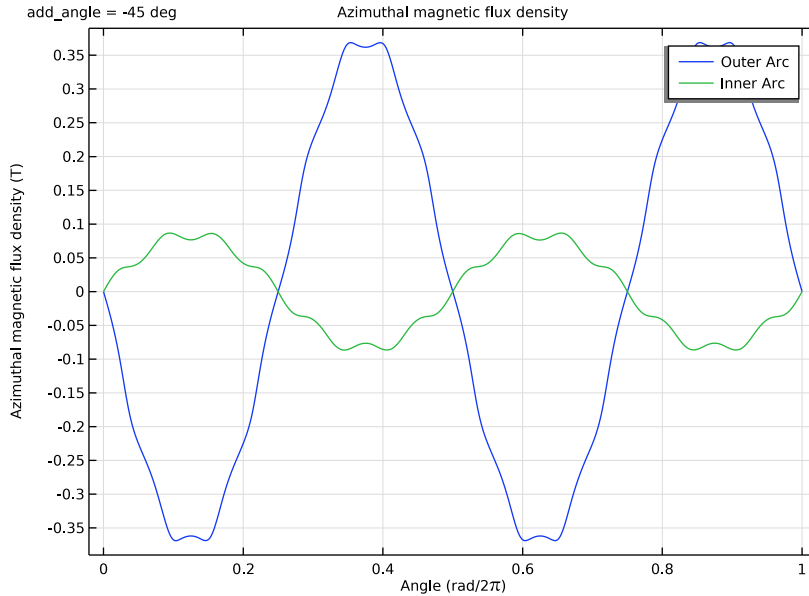

### Magnetic Flux Density Norm

- 1 In the **Results** toolbar, click  **Polar Plot Group**.
- 2 In the **Settings** window for **Polar Plot Group**, type Magnetic Flux Density Norm in the **Label** text field.
- 3 Locate the **Data** section. From the **Dataset** list, choose **Study 1 - Additional Angle Sweep/ Parametric Solutions 1 (sol2)**.
- 4 From the **Parameter selection (add\_angle)** list, choose **From list**.
- 5 In the **Parameter values (add\_angle (deg))** list box, select **-90**.
- 6 Click to expand the **Title** section. From the **Title type** list, choose **Manual**.
- 7 In the **Title** text area, type Magnetic flux density norm.
- 8 In the **Parameter indicator** text field, type `add_angle = eval(add_angle*180/pi)` deg.
- 9 Locate the **Axis** section. Select the **Manual axis limits** checkbox.

10 In the **r maximum** text field, type 0.85.

#### *Outer Arc*

- 1 In the **Magnetic Flux Density Norm** toolbar, click  **Line Graph**.
- 2 In the **Settings** window for **Line Graph**, type Outer Arc in the **Label** text field.
- 3 Locate the **Selection** section. From the **Selection** list, choose **Outer Arc (Arcs)**.
- 4 Locate the **r-Axis Data** section. In the **Expression** text field, type  $\text{mfnc.normB}$ .
- 5 Locate the  **$\theta$  Angle Data** section. From the **Parameter** list, choose **Expression**.
- 6 In the **Expression** text field, type  $\text{sys2.phi}$ .
- 7 Click to expand the **Legends** section. Select the **Show legends** checkbox.
- 8 Find the **Include** subsection. Select the **Label** checkbox.
- 9 Clear the **Solution** checkbox.

#### *Inner Arc*

- 1 Right-click **Outer Arc** and choose **Duplicate**.
- 2 In the **Settings** window for **Line Graph**, type Inner Arc in the **Label** text field.
- 3 Locate the **Selection** section. From the **Selection** list, choose **Inner Arc (Arcs)**.
- 4 In the **Magnetic Flux Density Norm** toolbar, click  **Plot**.

5 Click → **Plot Next**.

Compare the plot for `add_angle=-45[deg]` with the figure below.

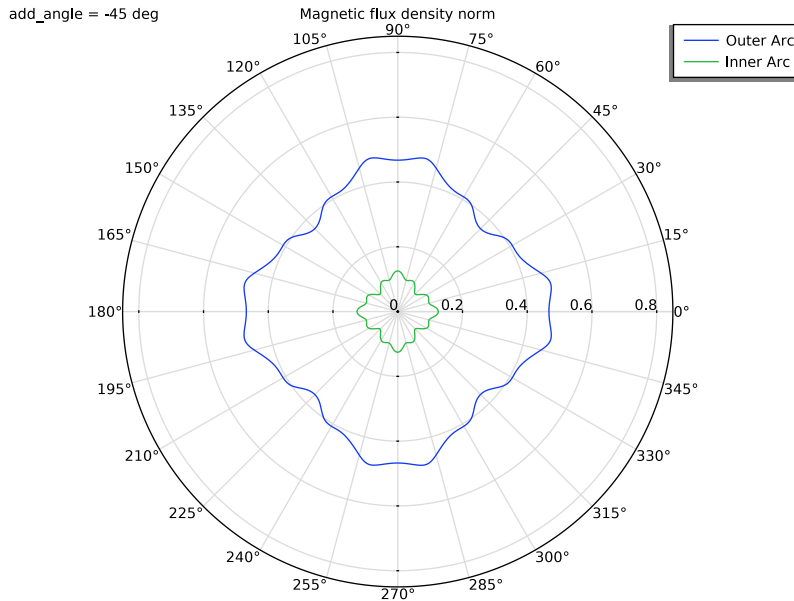

### 3D Magnetic Flux Density

- 1 In the **Results** toolbar, click  **3D Plot Group**.
- 2 In the **Settings** window for **3D Plot Group**, type 3D Magnetic Flux Density in the **Label** text field.
- 3 Locate the **Data** section. From the **Dataset** list, choose **Study 1 - Additional Angle Sweep/ Parametric Solutions 1 (sol2)**.
- 4 From the **Parameter value (add\_angle (deg))** list, choose **-45**.
- 5 Locate the **Plot Settings** section. Clear the **Plot dataset edges** checkbox.
- 6 Click to expand the **Title** section. From the **Title type** list, choose **Label**.
- 7 Click to collapse the **Title** section. Locate the **Color Legend** section. Select the **Show maximum and minimum values** checkbox.

### Volume 1

- 1 In the **3D Magnetic Flux Density** toolbar, click  **Volume**.
- 2 In the **Settings** window for **Volume**, locate the **Expression** section.
- 3 In the **Expression** text field, type `mfnc.normB`.

- 4 Locate the **Coloring and Style** section. From the **Color table** list, choose **Prism**.

#### *Selection 1*

- 1 Right-click **Volume 1** and choose **Selection**.
- 2 In the **Settings** window for **Selection**, locate the **Selection** section.
- 3 From the **Selection** list, choose **Magnets**.

#### *Filter 1*

- 1 In the **Model Builder** window, right-click **Volume 1** and choose **Filter**.
- 2 In the **Settings** window for **Filter**, locate the **Element Selection** section.
- 3 In the **Logical expression for inclusion** text field, type  $z < -1$  [mm].

#### *3D Magnetic Flux Density*

In the **3D Magnetic Flux Density** toolbar, click  **More Plots** and choose **Streamline Surface**.

#### *Streamline Surface 1*

- 1 In the **Settings** window for **Streamline Surface**, locate the **Data** section.
- 2 From the **Dataset** list, choose **Cut Plane - Additional Angle Sweep**.
- 3 From the **Solution parameters** list, choose **From parent**.
- 4 Locate the **Streamline Positioning** section. From the **Positioning** list, choose **Magnitude controlled**.
- 5 In the **Minimum density level** text field, type 2.
- 6 In the **Maximum density level** text field, type 11.

#### *Color Expression 1*

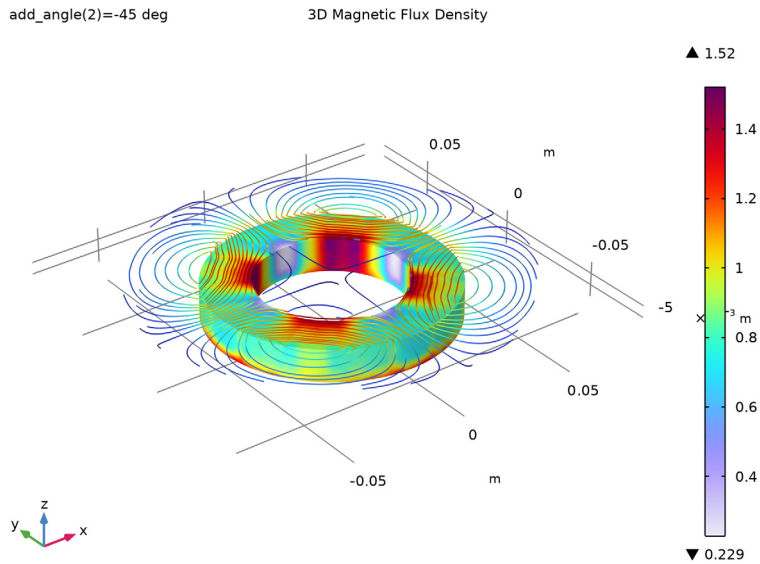

- 1 Right-click **Streamline Surface 1** and choose **Color Expression**.
- 2 In the **Settings** window for **Color Expression**, locate the **Expression** section.
- 3 In the **Expression** text field, type  $mfnc.nor mB$ .
- 4 Locate the **Coloring and Style** section. Clear the **Color legend** checkbox.
- 5 From the **Color table transformation** list, choose **Nonlinear**.
- 6 In the **Color calibration parameter** text field, type -0.8.
- 7 In the **3D Magnetic Flux Density** toolbar, click  **Plot**.

- Click the  **Transparency** button in the **Graphics** toolbar.  
Compare the 3D magnetic flux density plot with the figure below.



Create a new stationary study with its own parametric sweep over the parameter `n_segments`. This allows for a comparison of how the number of segments changes the magnetic field.



#### ADD STUDY

- In the **Home** toolbar, click  **Add Study** to open the **Add Study** window.
- Go to the **Add Study** window.
- Find the **Studies** subsection. In the **Select Study** tree, select **General Studies > Stationary**.
- Click the **Add Study** button in the window toolbar.
- In the **Home** toolbar, click  **Add Study** to close the **Add Study** window.

#### STUDY 2 - NUMBER OF SEGMENTS SWEEP

- In the **Settings** window for **Study**, type Study 2 - Number of Segments Sweep in the **Label** text field.
- Locate the **Study Settings** section. Clear the **Generate default plots** checkbox.

### Parametric Sweep

- 1 In the **Study** toolbar, click  **Parametric Sweep**.
- 2 In the **Settings** window for **Parametric Sweep**, locate the **Study Settings** section.
- 3 Click  **Add**.
- 4 In the table, enter the following settings:

Parameter name	Parameter value list	Parameter unit
n_segments (Number of magnet segments)	8 16 24 32	

Keep in mind that the number of segments is constrained such that  $n\_segments * add\_angle$  is an integer multiple of 360 degrees. This is to make sure a full rotation around the rotor results in the magnetization vector returning to its original orientation.

- 5 In the **Study** toolbar, click  **Compute**.

## RESULTS

Create a new cut plane for the new parametric sweep.

### Cut Plane - Number of Segments Sweep

- 1 In the **Results** toolbar, click  **Cut Plane**.
- 2 In the **Settings** window for **Cut Plane**, type Cut Plane - Number of Segments Sweep in the **Label** text field.
- 3 Locate the **Data** section. From the **Dataset** list, choose **Study 2 - Number of Segments Sweep/Parametric Solutions 2 (sol9)**.
- 4 Locate the **Plane Data** section. From the **Plane** list, choose **xy-planes**.

### Magnetic Flux Density, Number of Segments Sweep

- 1 In the **Model Builder** window, right-click **Magnetic Flux Density, Additional Angle Sweep** and choose **Duplicate**.
- 2 In the **Settings** window for **2D Plot Group**, type Magnetic Flux Density, Number of Segments Sweep in the **Label** text field.
- 3 Locate the **Data** section. From the **Dataset** list, choose **Cut Plane - Number of Segments Sweep**.
- 4 In the **Magnetic Flux Density, Number of Segments Sweep** toolbar, click  **Plot**.

Compare the magnetic flux densities corresponding to the different parameter values by clicking **Plot Previous** or **Plot Next**. Recreate the one-dimensional plot groups and the polar plot group for the new study.

#### *Radial Magnetic Flux Density - Number of Segments Sweep*

- 1 In the **Model Builder** window, right-click **Radial Magnetic Flux Density** and choose **Duplicate**.
- 2 In the **Settings** window for **ID Plot Group**, type Radial Magnetic Flux Density - Number of Segments Sweep in the **Label** text field.
- 3 Locate the **Data** section. From the **Dataset** list, choose **Study 2 - Number of Segments Sweep/Parametric Solutions 2 (sol9)**.
- 4 Locate the **Title** section. In the **Parameter indicator** text field, type `n_segments = eval(n_segments)`.
- 5 In the **Radial Magnetic Flux Density - Number of Segments Sweep** toolbar, click  **Plot**.

Compare the radial magnetic flux densities corresponding to the different parameter values by clicking **Plot Previous** or **Plot Next**.

#### *Azimuthal Magnetic Flux Density - Number of Segments Sweep*

- 1 In the **Model Builder** window, right-click **Azimuthal Magnetic Flux Density** and choose **Duplicate**.
- 2 In the **Settings** window for **ID Plot Group**, type Azimuthal Magnetic Flux Density - Number of Segments Sweep in the **Label** text field.
- 3 Locate the **Data** section. From the **Dataset** list, choose **Study 2 - Number of Segments Sweep/Parametric Solutions 2 (sol9)**.
- 4 Locate the **Title** section. In the **Parameter indicator** text field, type `n_segments = eval(n_segments)`.
- 5 In the **Azimuthal Magnetic Flux Density - Number of Segments Sweep** toolbar, click  **Plot**.

Compare the azimuthal magnetic flux densities corresponding to the different parameter values by clicking **Plot Previous** or **Plot Next**.

#### *Magnetic Flux Density Norm - Number of Segments Sweep*

- 1 In the **Model Builder** window, right-click **Magnetic Flux Density Norm** and choose **Duplicate**.
- 2 In the **Settings** window for **Polar Plot Group**, type Magnetic Flux Density Norm - Number of Segments Sweep in the **Label** text field.

- 3 Locate the **Data** section. From the **Dataset** list, choose **Study 2 - Number of Segments Sweep/Parametric Solutions 2 (sol9)**.
- 4 Locate the **Title** section. In the **Parameter indicator** text field, type `n_segments = eval(n_segments)`.
- 5 In the **Magnetic Flux Density Norm - Number of Segments Sweep** toolbar, click  **Plot**.  
Look through the magnetic flux density norms for the different parameters and note how the difference between the inner and outer arcs changes. Compare the polar plot for `n_segments=32` with the figure below.

