



Model created in COMSOL Multiphysics 6.4

Rotating Machinery 3D Tutorial

Introduction

This application serves as a general introduction to the Rotating Machinery, Magnetic interface in 3D. The circular motion of a cylindrical copper rotor near a stationary permanent magnet generates induced eddy currents in the rotor. The rotor has an axial cut representing an optional lamination. [Figure 1](#) shows the geometry with the rotor and stator.

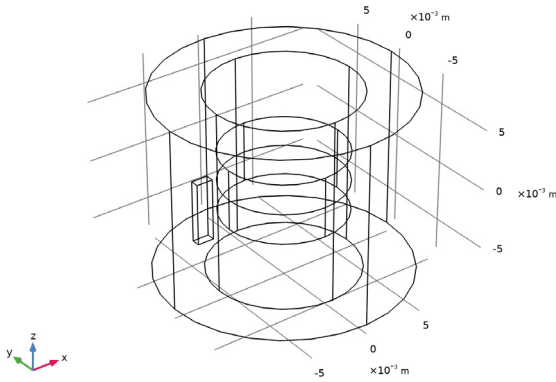

Figure 1: Drawing showing how the rotor and stator with the permanent magnet are defined.

Model Definition

This COMSOL Multiphysics application is a time-dependent 3D problem. It is a true time-dependent model where the motion of the rotor is accounted for in the boundary condition between the stator and rotor geometries. For the solid (nonlaminated) rotor the conducting part is modeled using Ampère's law:

$$\sigma \frac{\partial \mathbf{A}}{\partial t} + \nabla \times \left(\frac{1}{\mu} \nabla \times \mathbf{A} \right) = 0$$

In order to represent a laminated rotor where the electrically insulating material is truncated to a boundary, it is necessary to include the electric potential and set an insulating boundary condition. This model demonstrates how to manually couple the magnetic vector field formulation (\mathbf{A}) with the electric potential (V), as well as how to utilize the Passive Conductor feature which performs this coupling automatically. In either case, the result is the following formulation:

$$\sigma \frac{\partial \mathbf{A}}{\partial t} + \nabla \times (\mu^{-1} \nabla \times \mathbf{A}) + \sigma \nabla V = 0$$

$$-\nabla \cdot \left(\sigma \frac{\partial \mathbf{A}}{\partial t} + \sigma \nabla V \right) = \nabla \cdot \mathbf{J} = 0$$

In principle, there is also a displacement current density contribution but that is numerically negligible and is excluded in these equations.

The nonconducting parts of both the rotor and stator are modeled using a magnetic flux conservation equation for the scalar magnetic potential:

$$-\nabla \cdot (\mu \nabla V_m - \mathbf{B}_r) = 0$$

Rotation is modeled using a ready-made physics interface for rotating machinery. The central part of the geometry, containing the rotor and part of the air-gap, is modeled as rotating relative to the coordinate system of the stator. The rotor and the stator are created as two separate geometry objects, so it is possible to use an assembly (see the Geometry chapter in the *COMSOL Multiphysics Reference Manual* for details).

This has several advantages: the coupling between the rotor and the stator is done automatically, the parts can be meshed independently, and it allows for a controlled discontinuity in the scalar magnetic potential at the interface between the two geometry objects. The rotor problem is solved in a rotating coordinate system where the rotor is fixed (the rotor frame), whereas the stator problem is solved in a coordinate system that is fixed with respect to the stator (the stator frame). Using COMSOL terminology, they are both solved in the material frame. An identity pair connecting the rotating rotor frame with the fixed stator frame is created between the rotor and the stator. The identity pair enforces continuity for the magnetic scalar potential in the global fixed coordinate system (the stator frame relative to which the rotor rotates).

However, this means that in the frame on which continuity in the scalar magnetic potential is enforced, the meshes on either side of the rotor-stator interface cannot be made identical except for the case without any rotation so some interpolation between nonconforming meshes is involved. The resulting interpolation errors have little numerical impact if the assembly is created such that the resulting identity boundary pair only involves the scalar magnetic potential. In Ampère's law for the magnetic vector potential, current conservation is an implicit requirement that is violated if the identity boundary pair would involve interpolation of the magnetic vector potential. The resulting interpolation errors unconditionally make such a model numerically unstable. Thus, special care has to be exercised when setting up the geometry using assemblies in an application like this.

Note: An additional intricacy when using a mixed potential formulation involving both scalar and vector magnetic potentials is that the domains using the scalar magnetic potential must be simply connected. A domain is simply connected if any closed line integration path does not link an external domain. An example of a domain that is not simply connected is a torus (as a closed loop may link the central hole). This is a requirement imposed by the integral form of Ampère’s law as, for example, the hole in the torus may carry a current linking the torus. In the scalar magnetic potential formulation, closed loop line integrals of the H field must evaluate to zero.

Results and Discussion

The eddy current loss in the rotor is shown for the laminated and nonlaminated cases. The constant rotation speed is 3000 rpm.

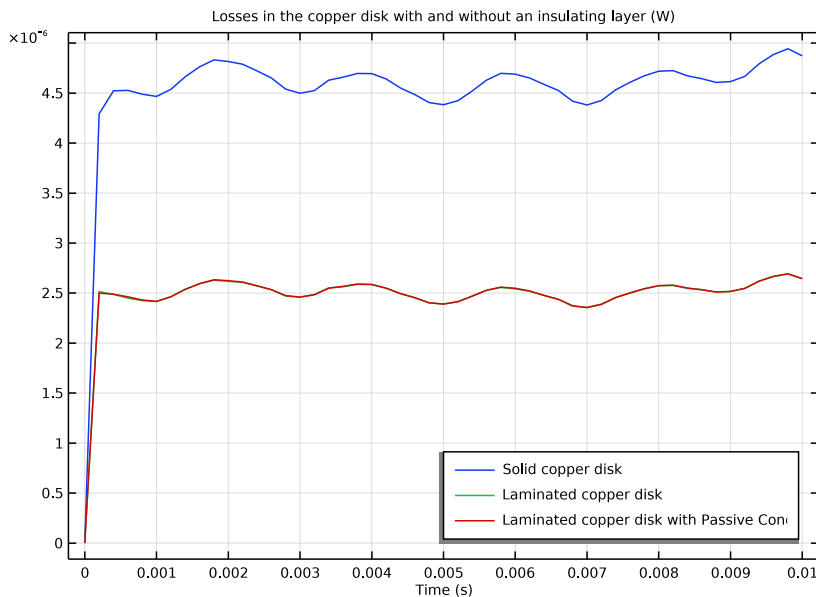



Figure 2: Eddy current loss comparison.

Application Library path: ACDC_Module/Devices,_Motors_and_Generators/
rotating_machinery_3d_tutorial



Modeling Instructions

From the **File** menu, choose **New**.

NEW

In the **New** window, click  **Model Wizard**.

MODEL WIZARD

- 1 In the **Model Wizard** window, click  **3D**.
- 2 In the **Select Physics** tree, select **AC/DC > Electromagnetics and Mechanics > Rotating Machinery, Magnetic (rmm)**.
- 3 Click **Add**.
- 4 Click  **Study**.



Add a stationary study to compute initial conditions. The time-dependent study will be added later before solving.

- 5 In the **Select Study** tree, select **General Studies > Stationary**.

- 6 Click  **Done**.

GEOMETRY I

The geometry must be segmented in at least two parts, the stator and the rotor, to allow relative rotation. The geometry sequence for this tutorial can be imported from a separate mph file.

- 1 In the **Geometry** toolbar, click **Insert Sequence** and choose **Insert Sequence**.
- 2 Browse to the model's Application Libraries folder and double-click the file `rotating_machinery_3d_tutorial_geom_sequence.mph`.
- 3 In the **Geometry** toolbar, click  **Build All**.
- 4 Click the  **Go to Default View** button in the **Graphics** toolbar.
- 5 Click the  **Wireframe Rendering** button in the **Graphics** toolbar.

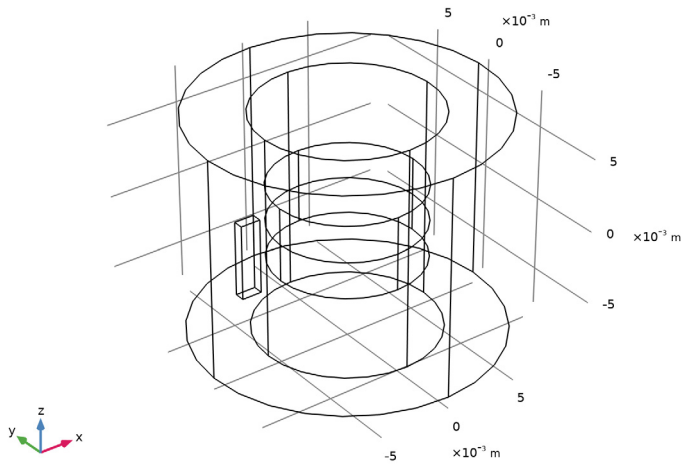

6 In the **Model Builder** window, under **Component 1 (comp1)** click **Geometry 1**.



A boundary pair is automatically created between rotor and stator.
Next, add explicit selections for the source and destination sides of the boundary pair.

DEFINITIONS

Identity Boundary Pair 1 (ap1)

- 1 In the **Model Builder** window, expand the **Component 1 (comp1)** > **Definitions** node, then click **Identity Boundary Pair 1 (ap1)**.
- 2 In the **Settings** window for **Pair**, locate the **Source Boundaries** section.
- 3 Click  **Create Selection**.
- 4 In the **Create Selection** dialog, type src in the **Selection name** text field.
- 5 Click **OK**.
- 6 In the **Settings** window for **Pair**, locate the **Destination Boundaries** section.
- 7 Click  **Create Selection**.
- 8 In the **Create Selection** dialog, type dst in the **Selection name** text field.
- 9 Click **OK**.



GLOBAL DEFINITIONS

Parameters 1

- 1 In the **Model Builder** window, under **Global Definitions** click **Parameters 1**.
- 2 In the **Settings** window for **Parameters**, locate the **Parameters** section.
- 3 In the table, enter the following settings:

Name	Expression	Value	Description
omega	3000[rpm]	50 1/s	Rotational velocity

ADD MATERIAL

- 1 In the **Materials** toolbar, click  **Add Material** to open the **Add Material** window.
- 2 Go to the **Add Material** window.
- 3 In the tree, select **Built-in** > **Air**.
- 4 Click the **Add to Component** button in the window toolbar.
- 5 In the tree, select **AC/DC** > **Copper**.
- 6 Right-click and choose **Add to Component 1 (comp1)**.
- 7 In the tree, select **AC/DC** > **Hard Magnetic Materials** > **Sintered NdFeB Grades (Chinese Standard)** > **N35 (Sintered NdFeB)**.
- 8 Right-click and choose **Add to Component 1 (comp1)**.
- 9 In the **Materials** toolbar, click  **Add Material** to close the **Add Material** window.

MATERIALS

Copper (mat2)

- 1 Select Domains 4 and 5 only.
- 2 In the **Settings** window for **Material**, locate the **Geometric Entity Selection** section.
- 3 Click  **Create Selection**.
- 4 In the **Create Selection** dialog, type Rotating disk in the **Selection name** text field.
- 5 Click **OK**.

N35 (Sintered NdFeB) (mat3)

- 1 In the **Model Builder** window, click **N35 (Sintered NdFeB) (mat3)**.
- 2 Select Domain 2 only.

ROTATING MACHINERY, MAGNETIC (RMM)

Use **Magnetic Flux Conservation** in the nonconducting domains and **Ampère's Law** in the conducting domains. Set up the permanent magnet with **Nonconducting Magnet** feature to disregard any induced currents in the magnet itself and save computational resources.

Air, Formulation for Nonconducting Domain

- 1 In the **Physics** toolbar, click  **Domains** and choose **Magnetic Flux Conservation**.
- 2 In the **Settings** window for **Magnetic Flux Conservation**, type **Air, Formulation for Nonconducting Domain** in the **Label** text field.
- 3 Select Domains 1 and 3 only.

Nonconducting Magnet 1

- 1 In the **Physics** toolbar, click  **Domains** and choose **Nonconducting Magnet**.
- 2 Select Domain 2 only.

North 1



- 1 In the **Model Builder** window, click **North 1**.
- 2 Select Boundary 10 only.

South 1

- 1 In the **Model Builder** window, click **South 1**.
- 2 Select Boundary 5 only.

Rotating machinery in 3D needs explicit gauge fixing of the vector potential.

Gauge Fixing for A-Field 1

- 1 In the **Physics** toolbar, click  **Domains** and choose **Gauge Fixing for A-Field**.
- 2 In the **Settings** window for **Gauge Fixing for A-Field**, locate the **Domain Selection** section.
- 3 From the **Selection** list, choose **Rotating disk**.
The gauge fixing needs to be constrained in at least one point. Explicitly enforce a constraint on the value.
- 4 Click the  **Show More Options** button in the **Model Builder** toolbar.
- 5 In the **Show More Options** dialog, in the tree, select the checkbox for the node **Physics > Advanced Physics Options**.
- 6 Click **OK**.
- 7 In the **Settings** window for **Gauge Fixing for A-Field**, click to expand the **Advanced Settings** section.
- 8 Select the **Ensure constraint on value** checkbox.

Specify the rotation of the rotor domain.

COMPONENT 1 (COMPI)

Rotating Domain 1

- 1 In the **Physics** toolbar, click  **Moving Mesh** and choose **Rotating Domain**.
- 2 Select Domains 3–5 only.
- 3 In the **Settings** window for **Rotating Domain**, locate the **Rotation** section.
- 4 From the **Rotation type** list, choose **Specified rotational velocity**.
- 5 In the ω text field, type omega.

ROTATING MACHINERY, MAGNETIC (RMM)

The scalar and vector potentials are connected via a special boundary condition, which is applied by default at the interface between the two formulations.

A continuity feature has to be added to specify the coupling across the pair. Note that pair features can be applied only if the same formulation is active on both sides of the pair. Pairs with moving (nonconforming) mesh are allowed only between **Magnetic Flux Conservation** domains.

Magnetic Continuity 1a

- 1 In the **Physics** toolbar, click  **Pairs** and choose **Magnetic Continuity**.
- 2 In the **Settings** window for **Magnetic Continuity**, locate the **Pair Selection** section.
- 3 Click **+ Add**.
- 4 In the **Add** dialog, select **Identity Boundary Pair 1 (ap1)** in the **Pairs** list.
- 5 Click **OK**.

The scalar potential also needs a point constraint, which is readily available as a standard point feature.

Zero Magnetic Scalar Potential 1

- 1 In the **Physics** toolbar, click  **Points** and choose **Zero Magnetic Scalar Potential**.
- 2 Select Point 1 only.

MESH 1

Some extra care is needed for the meshing of source and destination boundaries for the pair; the destination side needs a finer mesh than the source side. To get full control, mesh these surfaces separately. Use a boundary layer mesh for the copper domain to better resolve the expected velocity skin effect.

Free Triangular 1

- 1 In the **Mesh** toolbar, click  **More Generators** and choose **Free Triangular**.
- 2 In the **Settings** window for **Free Triangular**, locate the **Boundary Selection** section.
- 3 From the **Selection** list, choose **src**.

Size 1

- 1 Right-click **Free Triangular 1** and choose **Size**.
- 2 In the **Settings** window for **Size**, locate the **Element Size** section.
- 3 Click the **Custom** button.
- 4 Locate the **Element Size Parameters** section.
- 5 Select the **Maximum element size** checkbox. In the associated text field, type $2e-3$.

Free Triangular 2

- 1 In the **Mesh** toolbar, click  **More Generators** and choose **Free Triangular**.
- 2 In the **Settings** window for **Free Triangular**, locate the **Boundary Selection** section.
- 3 From the **Selection** list, choose **dst**.

Size 1

- 1 Right-click **Free Triangular 2** and choose **Size**.
- 2 In the **Settings** window for **Size**, locate the **Element Size** section.
- 3 Click the **Custom** button.
- 4 Locate the **Element Size Parameters** section.
- 5 Select the **Maximum element size** checkbox. In the associated text field, type $7e-4$.

Free Tetrahedral 1

In the **Mesh** toolbar, click  **Free Tetrahedral**.

Size 1

- 1 Right-click **Free Tetrahedral 1** and choose **Size**.
- 2 In the **Settings** window for **Size**, locate the **Geometric Entity Selection** section.
- 3 From the **Geometric entity level** list, choose **Boundary**.
- 4 Select Boundaries 5–10, 21–27, and 29–32 only.
- 5 Locate the **Element Size** section. Click the **Custom** button.
- 6 Locate the **Element Size Parameters** section.
- 7 Select the **Maximum element size** checkbox. In the associated text field, type $7e-4$.

Free Tetrahedral 1

- 1 In the **Model Builder** window, click **Free Tetrahedral 1**.
- 2 In the **Settings** window for **Free Tetrahedral**, locate the **Domain Selection** section.
- 3 From the **Geometric entity level** list, choose **Domain**.
- 4 Select Domains 1, 2, 4, and 5 only.

Boundary Layers 1

- 1 In the **Mesh** toolbar, click  **Boundary Layers**.
- 2 In the **Settings** window for **Boundary Layers**, locate the **Geometric Entity Selection** section.
- 3 From the **Geometric entity level** list, choose **Domain**.
- 4 From the **Selection** list, choose **Rotating disk**.

Boundary Layer Properties

- 1 In the **Model Builder** window, click **Boundary Layer Properties**.
- 2 Select Boundaries 21–27 and 29–32 only.
- 3 In the **Settings** window for **Boundary Layer Properties**, locate the **Layers** section.
- 4 From the **Thickness specification** list, choose **First layer**.
- 5 In the **Thickness** text field, type 1.0E-4.
- 6 In the **Number of layers** text field, type 2.
- 7 In the **Thickness** text field, type 7.0E-5.
- 8 In the **Stretching factor** text field, type 1.3.

Free Tetrahedral 2

- 1 In the **Mesh** toolbar, click  **Free Tetrahedral**.

2 In the **Settings** window for **Free Tetrahedral**, click  **Build All**.

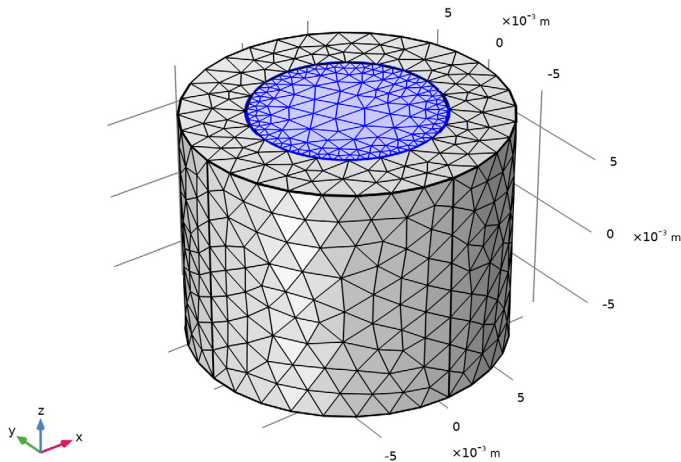



Configure the first study to simulate half a revolution with a sufficient number of time steps to resolve losses from induced currents.

SOLID COPPER DISK

- 1 In the **Model Builder** window, click **Study 1**.
- 2 In the **Settings** window for **Study**, type Solid Copper Disk in the **Label** text field.

Step 2: Time Dependent

- 1 In the **Study** toolbar, click  **Time Dependent**.
- 2 In the **Settings** window for **Time Dependent**, locate the **Study Settings** section.
- 3 In the **Output times** text field, type range(0, 1/100, 1/2)/omega.
- 4 In the **Study** toolbar, click  **Compute**.

RESULTS

Magnetic Flux Density (rmm)

In the **Magnetic Flux Density (rmm)** toolbar, click  **Plot**.

Now plot the induced eddy currents in the copper disk.

Currents and Solid Domain Boundaries Representation

1 In the **Results** toolbar, click  **3D Plot Group**.

- 2 In the **Settings** window for **3D Plot Group**, locate the **Plot Settings** section.
- 3 Clear the **Plot dataset edges** checkbox.
- 4 In the **Label** text field, type **Currents and Solid Domain Boundaries Representation**.
- 5 Locate the **Plot Settings** section. Click  **Go to Source**.

DEFINITIONS

View 1

- 1 In the **Model Builder** window, under **Component 1 (comp1) > Definitions** click **View 1**.
- 2 In the **Settings** window for **View**, locate the **View** section.
- 3 Clear the **Show grid** checkbox.

RESULTS

Surface 1

- 1 In the **Model Builder** window, right-click **Currents and Solid Domain Boundaries Representation** and choose **Surface**.
- 2 In the **Settings** window for **Surface**, locate the **Expression** section.
- 3 In the **Expression** text field, type 1.
- 4 Locate the **Coloring and Style** section. From the **Coloring** list, choose **Uniform**.
- 5 From the **Color** list, choose **Gray**.

Selection 1

- 1 Right-click **Surface 1** and choose **Selection**.
- 2 Select Boundaries 5–10, 23, and 29–32 only.

Arrow Volume 1



- 1 In the **Model Builder** window, right-click **Currents and Solid Domain Boundaries Representation** and choose **Arrow Volume**.
- 2 In the **Settings** window for **Arrow Volume**, click **Replace Expression** in the upper-right corner of the **Expression** section. From the menu, choose **Component 1 (comp1) > Rotating Machinery, Magnetic > Currents and charge > rmm.Jx,...,rmm.Jz - Current density (spatial frame)**.
- 3 Locate the **Arrow Positioning** section. Find the **x grid points** subsection. In the **Points** text field, type 10.
- 4 Find the **y grid points** subsection. In the **Points** text field, type 10.

- 5 Find the **z grid points** subsection. In the **Points** text field, type 10.
- 6 Locate the **Coloring and Style** section. From the **Arrow length** list, choose **Logarithmic**.
- 7 In the **Range quotient** text field, type 10.

Selection 1

- 1 Right-click **Arrow Volume 1** and choose **Selection**.
- 2 In the **Settings** window for **Selection**, locate the **Selection** section.
- 3 From the **Selection** list, choose **Rotating disk**.

Color Expression 1

- 1 In the **Model Builder** window, right-click **Arrow Volume 1** and choose **Color Expression**.
- 2 In the **Settings** window for **Color Expression**, locate the **Expression** section.
- 3 In the **Expression** text field, type `rmm.normJ`.
- 4 In the **Currents and Solid Domain Boundaries Representation** toolbar, click  **Plot**.
- 5 Click the  **Zoom Extents** button in the **Graphics** toolbar.

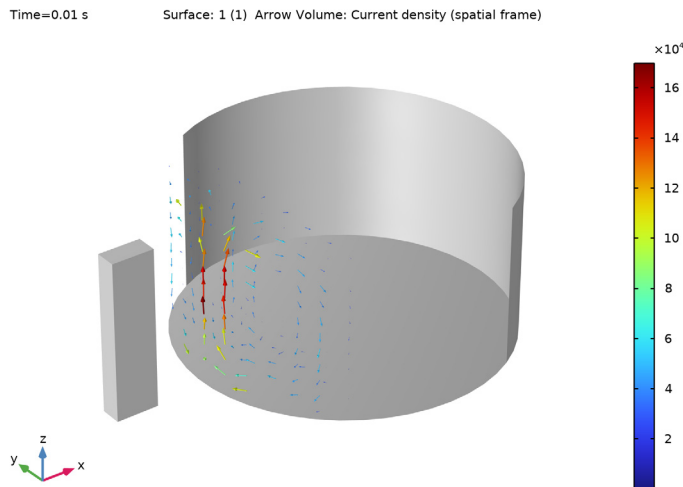

Compute the dissipated power in the copper disk.

Volume Integration 1

- 1 In the **Results** toolbar, click  **More Derived Values** and choose **Integration > Volume Integration**.
- 2 In the **Settings** window for **Volume Integration**, locate the **Selection** section.

- 3 From the **Selection** list, choose **Rotating disk**.
- 4 Locate the **Expressions** section. In the table, enter the following settings:

Expression	Unit	Description
rmm.Qh	W	Volumetric loss density, electromagnetic

- 5 Click  next to  **Evaluate**, then choose **New Table**.



TABLE 1

- 1 Go to the **Table 1** window.
Plot the tabulated dissipated power for the bulk copper disc.
- 2 Click the **Table Graph** button in the window toolbar.

Adding an Internal Insulating Layer as a Boundary Condition

In an electromagnetic formulation using the vector potential **A** only, the interior electric insulation boundary condition is not available. This limitation is overcome by introducing the scalar electric potential **V** by adding a properly coupled **Electric Currents** physics interface which has a built-in electric insulation boundary condition.

ADD PHYSICS

- 1 In the **Home** toolbar, click  **Add Physics** to open the **Add Physics** window.
- 2 Go to the **Add Physics** window.
- 3 In the tree, select **AC/DC** > **Electric Fields and Currents** > **Electric Currents (ec)**.
- 4 Click the **Add to Component 1** button in the window toolbar.
- 5 In the **Home** toolbar, click  **Add Physics** to close the **Add Physics** window.

ELECTRIC CURRENTS (EC)

- 1 In the **Settings** window for **Electric Currents**, locate the **Domain Selection** section.
- 2 From the **Selection** list, choose **Rotating disk**.
- 3 Click to expand the **Discretization** section. From the **Electric potential** list, choose **Linear**.

External Current Density I

- 1 In the **Physics** toolbar, click  **Domains** and choose **External Current Density**.
- 2 In the **Settings** window for **External Current Density**, locate the **Domain Selection** section.
- 3 From the **Selection** list, choose **Rotating disk**.

4 Locate the **External Current Density** section. Specify the \mathbf{J}_e vector as

rmm.Jix	x
rmm.Jiy	y
rmm.Jiz	z

Electric Insulation 2

- 1 In the **Physics** toolbar, click  **Boundaries** and choose **Electric Insulation**.
- 2 Select Boundary 26 only.

In the absence of external boundary conditions on the electric potential, its level has to be fixed by point conditions on both sides of the internal electrically insulating boundary.

Electric Potential 1

- 1 In the **Physics** toolbar, click  **Points** and choose **Electric Potential**.
- 2 Select Points 27 and 29 only.

ROTATING MACHINERY, MAGNETIC (RMM)



External Current Density 1

- 1 In the **Physics** toolbar, click  **Domains** and choose **External Current Density**.
- 2 In the **Settings** window for **External Current Density**, locate the **Domain Selection** section.
- 3 From the **Selection** list, choose **Rotating disk**.
- 4 Locate the **External Current Density** section. Specify the \mathbf{J}_e vector as

ec.Jx-rmm.Jix	x
ec.Jy-rmm.Jiy	y
ec.Jz-rmm.Jiz	z

Set up a second study for the solution with the insulating layer in the copper disk.

ADD STUDY

- 1 In the **Home** toolbar, click  **Add Study** to open the **Add Study** window.
- 2 Go to the **Add Study** window.
- 3 Find the **Studies** subsection. In the **Select Study** tree, select **General Studies > Stationary**.
- 4 Click the **Add Study** button in the window toolbar.
- 5 In the **Home** toolbar, click  **Add Study** to close the **Add Study** window.

SOLID COPPER DISK

Step 2: Time Dependent

In the **Model Builder** window, under **Solid Copper Disk** right-click **Step 2: Time Dependent** and choose **Copy**.

LAMINATED COPPER DISK

- 1 In the **Model Builder** window, click **Study 2**.
- 2 In the **Settings** window for **Study**, type Laminated Copper Disk in the **Label** text field.
- 3 Right-click **Laminated Copper Disk** and choose **Paste Time Dependent**.

SOLID COPPER DISK

Disable the newly added physics in the first study so that it reproduces the same results when run.

Step 1: Stationary

- 1 In the **Model Builder** window, under **Solid Copper Disk** click **Step 1: Stationary**.
- 2 In the **Settings** window for **Stationary**, locate the **Physics and Variables Selection** section.
- 3 Select the **Modify model configuration for study step** checkbox.
- 4 In the tree, select **Component 1 (comp1) > Rotating Machinery, Magnetic (rmm), Controls spatial frame > External Current Density 1**.
- 5 Right-click and choose **Disable**.
- 6 In the tree, select **Component 1 (comp1) > Electric Currents (ec)**.
- 7 Right-click and choose **Disable in Model**.

Step 2: Time Dependent

- 1 In the **Model Builder** window, click **Step 2: Time Dependent**.
- 2 In the **Settings** window for **Time Dependent**, locate the **Physics and Variables Selection** section.
- 3 Select the **Modify model configuration for study step** checkbox.
- 4 In the tree, select **Component 1 (comp1) > Rotating Machinery, Magnetic (rmm), Controls spatial frame > External Current Density 1**.
- 5 Right-click and choose **Disable**.
- 6 In the tree, select **Component 1 (comp1) > Electric Currents (ec)**.
- 7 Right-click and choose **Disable in Model**.

LAMINATED COPPER DISK

In the **Study** toolbar, click  **Compute**.

RESULTS

Magnetic Flux Density (rmm) I

In the **Magnetic Flux Density (rmm) I** toolbar, click  **Plot**.

Add a plot representing the z-component of the current which is zero on the insulating gap. It should reproduce figure below.

Current Perpendicular to the Insulating Plane

- 1 In the **Results** toolbar, click  **3D Plot Group**.
- 2 In the **Settings** window for **3D Plot Group**, type Current Perpendicular to the Insulating Plane in the **Label** text field.
- 3 Locate the **Data** section. From the **Dataset** list, choose **Laminated Copper Disk/ Solution 3 (sol3)**.
- 4 From the **Time (s)** list, choose **0.01**.

Volume I

- 1 Right-click **Current Perpendicular to the Insulating Plane** and choose **Volume**.
- 2 In the **Settings** window for **Volume**, locate the **Expression** section.
- 3 In the **Expression** text field, type $rmm \cdot Jz$.
- 4 In the **Unit** field, type A/mm^2 .
- 5 Locate the **Coloring and Style** section. From the **Color table** list, choose **WaveLight**.
- 6 From the **Scale** list, choose **Linear symmetric**.

7 In the **Current Perpendicular to the Insulating Plane** toolbar, click  **Plot**.

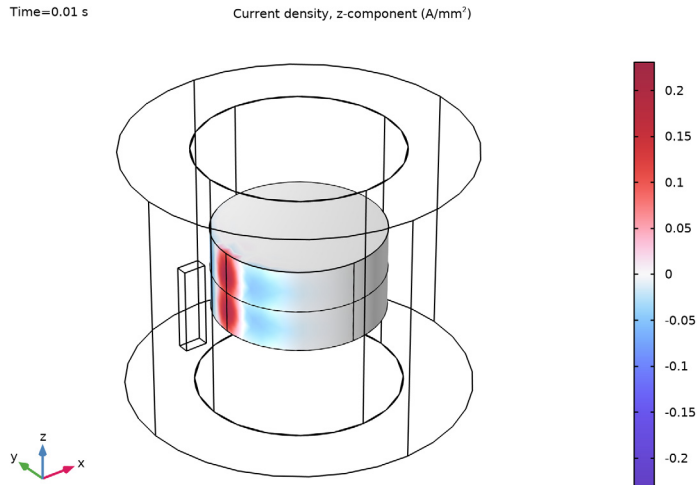

8 Click  **Plot**.

Verify that for the nonlaminated case, the z-component of the current is high on the midplane as shown in the plot below.

Current Perpendicular to the Insulating Plane

- 1 In the **Model Builder** window, click **Current Perpendicular to the Insulating Plane**.
- 2 In the **Settings** window for **3D Plot Group**, locate the **Data** section.
- 3 From the **Dataset** list, choose **Solid Copper Disk/Solution 1 (sol1)**.

4 In the **Current Perpendicular to the Insulating Plane** toolbar, click  **Plot**.

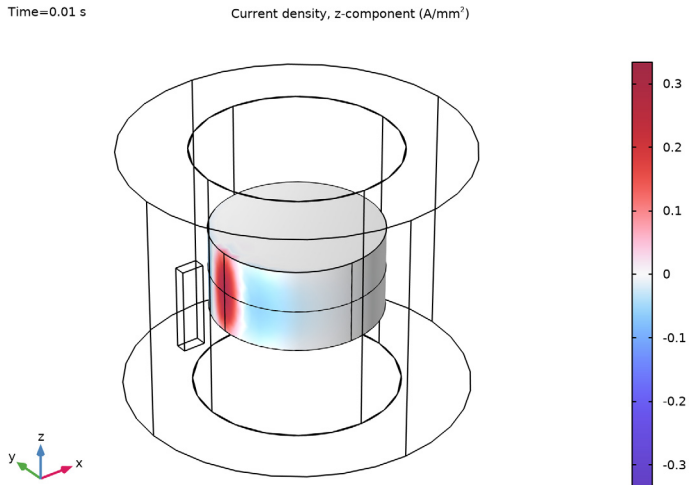

Add a new column to the previously generated table and update the corresponding plot with the losses for the laminated disk. The latter case, features decreased losses as expected.

Volume Integration 2



- 1 In the **Model Builder** window, under **Results > Derived Values** right-click **Volume Integration 1** and choose **Duplicate**.
- 2 In the **Settings** window for **Volume Integration**, locate the **Data** section.
- 3 From the **Dataset** list, choose **Laminated Copper Disk/Solution 3 (sol3)**.
- 4 Click  next to  **Evaluate**, then choose **Table 1 - Volume Integration 1**.

Table Graph 1

- 1 In the **Model Builder** window, under **Results > ID Plot Group 3** click **Table Graph 1**.
- 2 In the **Settings** window for **Table Graph**, click to expand the **Legends** section.
- 3 Select the **Show legends** checkbox.
- 4 From the **Legends** list, choose **Manual**.
- 5 In the table, enter the following settings:

Legends

Solid copper disk

Laminated copper disk

Losses in the Copper Disk

- 1 In the **Model Builder** window, click **ID Plot Group 3**.
- 2 In the **Settings** window for **ID Plot Group**, click to expand the **Title** section.
- 3 In the **Label** text field, type **Losses in the Copper Disk**.
- 4 Locate the **Title** section. From the **Title type** list, choose **Manual**.
- 5 In the **Title** text area, type **Losses in the copper disk with and without an insulating layer (W)**.
- 6 Locate the **Legend** section. From the **Position** list, choose **Lower right**.
- 7 In the **Losses in the Copper Disk** toolbar, click  **Plot**.

For the final analysis, add a **Passive Conductor** feature in order to compare with manual A+V coupling. The default setting for constraining of induced currents, **Within each domain**, imposes an electrically insulating boundary on all internal as well as external boundaries of the selected domains.

ROTATING MACHINERY, MAGNETIC (RMM)

Passive Conductor I

- 1 In the **Physics** toolbar, click  **Domains** and choose **Passive Conductor**.
- 2 In the **Settings** window for **Passive Conductor**, locate the **Domain Selection** section.
- 3 From the **Selection** list, choose **Rotating disk**.

The following steps ensure that the already added studies do not include the **Passive Conductor** feature if re-solved.

SOLID COPPER DISK

Step 1: Stationary

- 1 In the **Model Builder** window, under **Solid Copper Disk** click **Step 1: Stationary**.
- 2 In the **Settings** window for **Stationary**, locate the **Physics and Variables Selection** section.
- 3 In the tree, select **Component 1 (comp1) > Rotating Machinery, Magnetic (rmm), Controls spatial frame > Passive Conductor 1**.
- 4 Click  **Disable**.

Step 2: Time Dependent

- 1 In the **Model Builder** window, click **Step 2: Time Dependent**.
- 2 In the **Settings** window for **Time Dependent**, locate the **Physics and Variables Selection** section.

3 In the tree, select **Component 1 (comp1) > Rotating Machinery, Magnetic (rmm), Controls spatial frame > Passive Conductor 1**.

4 Click  **Disable**.

LAMINATED COPPER DISK

Step 1: Stationary

1 In the **Model Builder** window, under **Laminated Copper Disk** click **Step 1: Stationary**.

2 In the **Settings** window for **Stationary**, locate the **Physics and Variables Selection** section.

3 Select the **Modify model configuration for study step** checkbox.

4 In the tree, select **Component 1 (comp1) > Rotating Machinery, Magnetic (rmm), Controls spatial frame > Passive Conductor 1**.

5 Click  **Disable**.

Step 2: Time Dependent

1 In the **Model Builder** window, click **Step 2: Time Dependent**.

2 In the **Settings** window for **Time Dependent**, locate the **Physics and Variables Selection** section.

3 Select the **Modify model configuration for study step** checkbox.

4 In the tree, select **Component 1 (comp1) > Rotating Machinery, Magnetic (rmm), Controls spatial frame > Passive Conductor 1**.

5 Click  **Disable**.

Add a study for analysis with Passive Conductor feature and configure according to previous studies.

ADD STUDY

1 In the **Home** toolbar, click  **Add Study** to open the **Add Study** window.

2 Go to the **Add Study** window.

3 Find the **Studies** subsection. In the **Select Study** tree, select **General Studies > Stationary**.

4 Click the **Add Study** button in the window toolbar.

5 In the **Home** toolbar, click  **Add Study** to close the **Add Study** window.



STUDY 3

Step 1: Stationary

1 In the **Settings** window for **Stationary**, locate the **Physics and Variables Selection** section.

- 2 In the **Solve for** column of the table, under **Component 1 (comp1)**, clear the checkbox for **Electric Currents (ec)**.
- 3 Select the **Modify model configuration for study step** checkbox.
- 4 In the tree, select **Component 1 (comp1) > Rotating Machinery, Magnetic (rmm), Controls spatial frame > External Current Density 1**.
- 5 Click  **Disable**.

Step 2: Time Dependent

- 1 In the **Study** toolbar, click  **Time Dependent**.
- 2 In the **Settings** window for **Time Dependent**, locate the **Study Settings** section.
- 3 In the **Output times** text field, type range $(0, 1/100, 1/2) / \omega$.
- 4 Locate the **Physics and Variables Selection** section. In the **Solve for** column of the table, under **Component 1 (comp1)**, clear the checkbox for **Electric Currents (ec)**.
- 5 Select the **Modify model configuration for study step** checkbox.
- 6 In the tree, select **Component 1 (comp1) > Rotating Machinery, Magnetic (rmm), Controls spatial frame > External Current Density 1**.
- 7 Click  **Disable**.
- 8 In the **Model Builder** window, click **Study 3**.
- 9 In the **Settings** window for **Study**, type Laminated Copper Disk with Passive Conductor in the **Label** text field.
- 10 In the **Study** toolbar, click  **Compute**.

Finalize the addition of the plot and verify that it is similar to the one below.

RESULTS

Volume Integration 3

- 1 In the **Model Builder** window, under **Results > Derived Values** right-click **Volume Integration 2** and choose **Duplicate**.
- 2 In the **Settings** window for **Volume Integration**, locate the **Data** section.
- 3 From the **Dataset** list, choose **Laminated Copper Disk with Passive Conductor/ Solution 5 (sol5)**.
- 4 Click  **Evaluate**.

Table Graph 1

- 1 In the **Model Builder** window, under **Results > Losses in the Copper Disk** click **Table Graph 1**.

- 2 In the **Settings** window for **Table Graph**, locate the **Legends** section.
- 3 In the table, enter the following settings:

Legends

Solid copper disk

Laminated copper disk

Laminated copper disk with Passive Conductor

- 4 In the **Losses in the Copper Disk** toolbar, click  **Plot**.

