



Model created in COMSOL Multiphysics 6.4

# An RFID System

## *Introduction*

---

This example illustrates the modeling of a reader-transponder pair for radio-frequency identification (RFID) applications.

An RFID system consists of two main parts:

- A tag or transponder with a printed circuit-board (PCB) antenna
- A reader unit with a larger RF antenna

The reader antenna generates an electromagnetic field that energizes a chip (IC-circuit) inside the tag. The electromagnetic field is modulated by the tag's circuit and the modulated signal is recovered by the reader antenna.

The transponder antenna is typically a conductor pattern on a substrate:

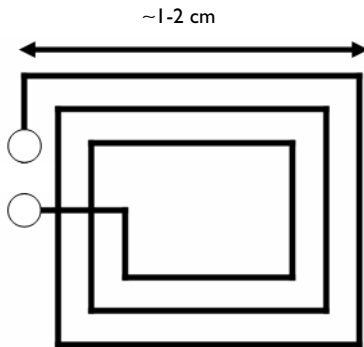

and a common type of reader antenna is a larger dual coil:

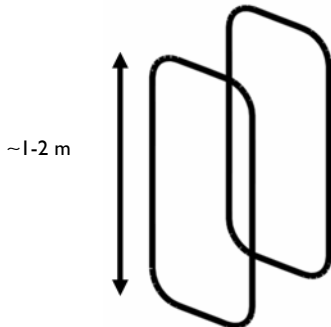

## INDUCTIVE COUPLING

The coupling of the antennas is mainly inductive and is characterized by the mutual inductance, denoted  $L_{12}$ . The mutual inductance is defined as the total magnetic flux intercepted by one antenna for a unit current flowing in the other antenna

$$L_{12} = \frac{\iint \mathbf{B} \cdot \mathbf{n} dS}{I_1} \quad (1)$$

where  $S_2$  is the area of coil number 2,  $\mathbf{B}$  is the flux intercepted by coil 2,  $I_1$  is the current running in coil number 1,  $\mathbf{n} = (n_x, n_y, n_z)$  is the unit surface normal vector, and  $dS$  is an infinitesimal area element.

It is possible to transform the surface integral in Equation 1 into a simpler line integral by using the magnetic vector potential

$$\mathbf{B} = \nabla \times \mathbf{A}$$

together with Stokes' theorem, which states that a surface integral of the curl of a field equals the closed line integral over the rim of the surface:

$$L_{12} = \frac{\iint (\nabla \times \mathbf{A}) \cdot \mathbf{n} dS}{I_1} = \frac{\oint \mathbf{A} \cdot \mathbf{t} dl}{I_1}$$

Here  $\mathbf{t} = (t_x, t_y, t_z)$  is the unit tangent vector of the curve  $\Gamma_S$  and  $dl$  is an infinitesimal line element.

Because the coupling is dominated by near-field inductive effects, it is sufficient to compute the mutual inductance for the static case (frequency equals zero) and neglect capacitive effects along with wave propagation phenomena. The appropriate physics to use is called Magnetic Fields and is available in the AC/DC Module. It has the magnetic vector potential  $\mathbf{A} = (A_x, A_y, A_z)$  as its unknown field quantity.

## EDGE COMPUTATIONS

This example approximates coils and wires as edges (1D entities) embedded in 3D space and the variables and techniques used are somewhat different than for a regular magnetostatics boundary value problem. The magnetic vector potential components are available at edges as the variables  $tAx$ ,  $tAy$ , and  $tAz$ , which form the projection of the vector potential on edges. On the other hand, the bulk components are denoted  $Ax$ ,  $Ay$ , and  $Az$ .

## Results

The computed value for the mutual inductance  $L_{12}$  is 0.99 nH. Figure 1 shows magnetic flux lines projected on the xy-plane and the magnetic flux density as colors.

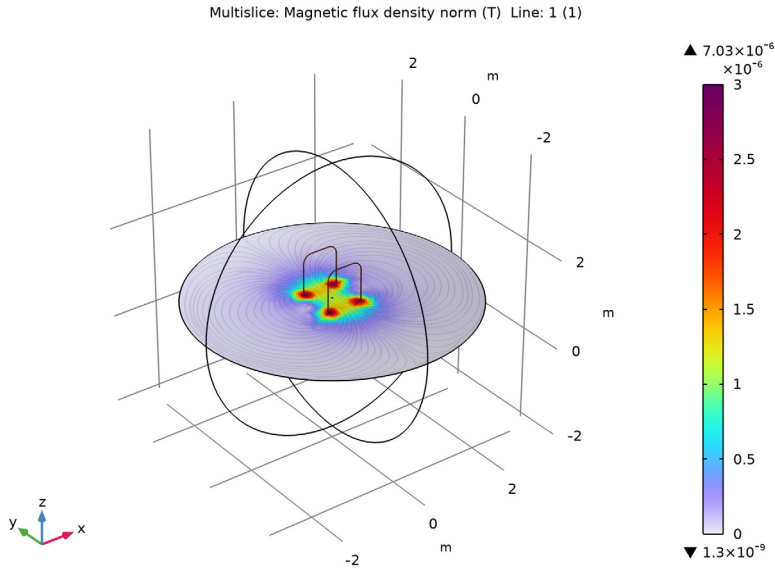

Figure 1: Magnetic flux density and flux line projections on the xy-plane. The contours of the reader antenna are visible in the center of the plot.

---

**Application Library path:** ACDC\_Module/Introductory\_Magnetostatics/rfid

---

## Modeling Instructions

From the **File** menu, choose **New**.



### NEW

In the **New** window, click  **Model Wizard**.

### MODEL WIZARD



1 In the **Model Wizard** window, click  **3D**.

2 In the **Select Physics** tree, select **AC/DC** > **Electromagnetic Fields** > **Magnetic Fields (mf)**.

- 3 Click **Add**.
- 4 Click  **Study**.
- 5 In the **Select Study** tree, select **General Studies > Stationary**.
- 6 Click  **Done**.

### GEOMETRY I

Insert the geometry sequence from the `rfid_geom_sequence.mph` file.

- 1 In the **Geometry** toolbar, click **Insert Sequence** and choose **Insert Sequence**.
- 2 Browse to the model's Application Libraries folder and double-click the file `rfid_geom_sequence.mph`.
- 3 In the **Geometry** toolbar, click  **Build All**.
- 4 Click the  **Wireframe Rendering** button in the **Graphics** toolbar.
- 5 Click the  **Zoom Extents** button in the **Graphics** toolbar.
- 6 In the **Model Builder** window, under **Component 1 (comp1)** click **Geometry I**.

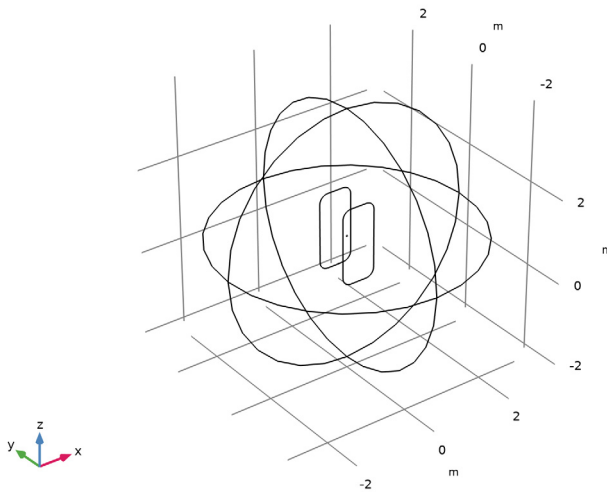

Disable the analysis of the geometry as the remaining small geometric details are needed.

- 7 In the **Model Builder** window, click **Geometry I**.
- 8 In the **Settings** window for **Geometry**, locate the **Cleanup** section.
- 9 Clear the **Automatic detection of small details** checkbox.

## DEFINITIONS

Define a number of edge selections to be used when setting up the physics and in postprocessing.

### Transponder

- 1 In the **Definitions** toolbar, click  **Explicit**.
- 2 In the **Settings** window for **Explicit**, type Transponder in the **Label** text field.
- 3 Locate the **Input Entities** section. From the **Geometric entity level** list, choose **Edge**.
- 4 Zoom in a few times so that you can clearly see the transponder antenna.
- 5 Use the **Select Box** tool to select the transponder antenna. Verify that the selected edges are 15-23, 29-34, and 38-40.

### Reader 1

- 1 In the **Definitions** toolbar, click  **Explicit**.
- 2 In the **Settings** window for **Explicit**, type Reader 1 in the **Label** text field.
- 3 Locate the **Input Entities** section. From the **Geometric entity level** list, choose **Edge**.
- 4 Select all the edges of the reader coil *behind* the transponder. Verify that you have selected edges 8-10, 13, 14, 43, 44, and 46 only.



### Reader 2

- 1 In the **Definitions** toolbar, click  **Explicit**.
- 2 In the **Settings** window for **Explicit**, type Reader 2 in the **Label** text field.
- 3 Locate the **Input Entities** section. From the **Geometric entity level** list, choose **Edge**.
- 4 Select all the edges of the reader *in front of* the transponder. Verify that you have selected edges 5-7, 11, 12, 41, 42, and 45.

## MATERIALS

Add Air as the material for the domain. The coils and the transponder are modeled as ideal edges so no material properties are needed.

## ADD MATERIAL

- 1 In the **Materials** toolbar, click  **Add Material** to open the **Add Material** window.
- 2 Go to the **Add Material** window.
- 3 In the tree, select **Built-in > Air**.
- 4 Click the **Add to Component** button in the window toolbar.
- 5 In the **Materials** toolbar, click  **Add Material** to close the **Add Material** window.

## MATERIALS

*Air (mat1)*

. The material is applied automatically to all domains.

## MAGNETIC FIELDS (MF)

Add two Edge Current features to model the coils as ideal line currents. When applying the features on edges, the reference direction for the current flow is indicated by arrows on the edge selection in the **Graphics** window. A negative value means that the edge current will flow in the direction opposite to the arrow.

*Edge Current 1*

- 1 In the **Physics** toolbar, click  **Edges** and choose **Edge Current**.
- 2 In the **Settings** window for **Edge Current**, locate the **Edge Selection** section.
- 3 From the **Selection** list, choose **Reader 1**.
- 4 Locate the **Edge Current** section. In the  $I_0$  text field, type 1.

*Edge Current 2*

- 1 In the **Physics** toolbar, click  **Edges** and choose **Edge Current**.
- 2 In the **Settings** window for **Edge Current**, locate the **Edge Selection** section.
- 3 From the **Selection** list, choose **Reader 2**.
- 4 Locate the **Edge Current** section. In the  $I_0$  text field, type -1.

The default boundary condition for the faces that constitute the sphere is **Magnetic Insulation**. This allows for surface currents to run across the sphere in such a way as to make the tangential component of the magnetic vector potential equal to zero. This is a good approximation in place of an infinite domain. It approximates that the tangential component of the vector potential approaches zero as the distance from the coils approaches infinity. Thus there is no need to change the boundary settings.

## MESH 1

- 1 In the **Model Builder** window, under **Component 1 (comp1)** click **Mesh 1**.
- 2 In the **Settings** window for **Mesh**, locate the **Physics-Controlled Mesh** section.
- 3 From the **Element size** list, choose **Coarser**.
- 4 Right-click **Component 1 (comp1)** > **Mesh 1** and choose **Edit Physics-Induced Sequence**.

*Size*

- 1 In the **Model Builder** window, under **Component 1 (comp1)** > **Mesh 1** click **Size**.
- 2 In the **Settings** window for **Size**, locate the **Element Size Parameters** section.

3 In the **Minimum element size** text field, type 0.0025.

4 Click  **Build All**.

## STUDY I

In the **Study** toolbar, click  **Compute**.

## RESULTS

### *Magnetic Flux Density (mf)*

In the **Magnetic Flux Density (mf)** toolbar, click  **Plot**.

### *Streamline Multislice I*

The default plot shows the magnetic flux density norm in three cross sections. Follow the instructions to get a more informative plot of the fields in the air domain surrounding the coils.

1 In the **Model Builder** window, expand the **Magnetic Flux Density (mf)** node, then click **Streamline Multislice I**.

2 In the **Settings** window for **Streamline Multislice**, locate the **Multiplane Data** section.

3 Find the **x-planes** subsection. From the **Entry method** list, choose **Number of planes**.

4 In the **Planes** text field, type 0.

5 Find the **y-planes** subsection. From the **Entry method** list, choose **Number of planes**.

6 In the **Planes** text field, type 0.

### *Multislice I*

1 In the **Model Builder** window, click **Multislice I**.

2 In the **Settings** window for **Multislice**, locate the **Multiplane Data** section.

3 Find the **x-planes** subsection. From the **Entry method** list, choose **Number of planes**.

4 In the **Planes** text field, type 0.

5 Find the **y-planes** subsection. From the **Entry method** list, choose **Number of planes**.

6 In the **Planes** text field, type 0.

7 In the **Magnetic Flux Density (mf)** toolbar, click  **Plot**.

The plot is dominated by the singular flux density where the reader antennas intersect the slice. One way to suppress the singularities in the plot, is by modifying the color range.

8 Click to expand the **Range** section. Select the **Manual color range** checkbox.

9 In the **Minimum** text field, type 0.

10 In the **Maximum** text field, type 3E-6.

11 In the **Magnetic Flux Density (mf)** toolbar, click  **Plot**.

Next, add a line plot to reproduce [Figure 1](#).

#### *Line 1*

1 In the **Model Builder** window, right-click **Magnetic Flux Density (mf)** and choose **Line**.

2 In the **Settings** window for **Line**, locate the **Expression** section.

3 In the **Expression** text field, type 1.

4 Locate the **Coloring and Style** section. From the **Line type** list, choose **Tube**.

5 In the **Tube radius expression** text field, type 1[cm].

6 Select the **Radius scale factor** checkbox.

#### *Selection 1*

1 Right-click **Line 1** and choose **Selection**.

2 In the **Settings** window for **Selection**, locate the **Selection** section.

3 Click  **Paste Selection**.

4 In the **Paste Selection** dialog, type 5 6 7 8 9 10 11 12 13 14 41 42 43 44 45 46 in the **Selection** text field.

5 Click **OK**.

#### *Material Appearance 1*

1 In the **Model Builder** window, right-click **Line 1** and choose **Material Appearance**.

2 In the **Settings** window for **Material Appearance**, locate the **Appearance** section.

3 From the **Appearance** list, choose **Custom**.

4 From the **Material type** list, choose **Copper**.

5 In the **Magnetic Flux Density (mf)** toolbar, click  **Plot**.

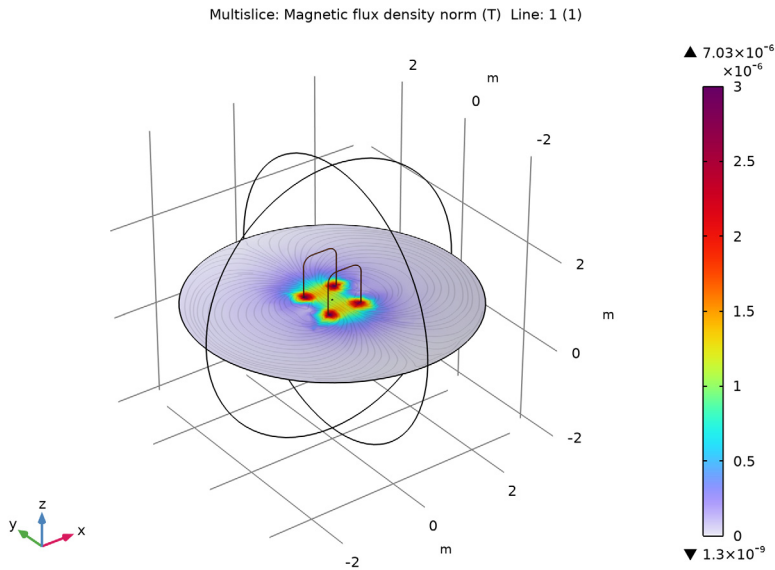

As a final step, evaluate the mutual inductance by integrating the magnetic vector potential along the transponder coil; first, analyze the verification of the intended transponder coil direction, then perform the integral.

#### Transponder Currents Direction



- 1 In the **Results** toolbar, click  **3D Plot Group**.
- 2 In the **Settings** window for **3D Plot Group**, locate the **Plot Settings** section.
- 3 Clear the **Plot dataset edges** checkbox.
- 4 In the **Label** text field, type Transponder Currents Direction.

#### Arrow Line 1

- 1 Right-click **Transponder Currents Direction** and choose **Arrow Line**.
- 2 In the **Settings** window for **Arrow Line**, locate the **Expression** section.
- 3 In the **x-component** text field, type  $t1x$ .
- 4 In the **y-component** text field, type  $t1y$ .
- 5 In the **z-component** text field, type  $t1z$ .

#### Selection 1

- 1 Right-click **Arrow Line 1** and choose **Selection**.

- 2 In the **Settings** window for **Selection**, locate the **Selection** section.
- 3 From the **Selection** list, choose **Transponder**.
- 4 In the **Transponder Currents Direction** toolbar, click  **Plot**.
- 5 Click the  **Zoom Extents** button in the **Graphics** toolbar.
- 6 Click the  **Show Grid** button in the **Graphics** toolbar.

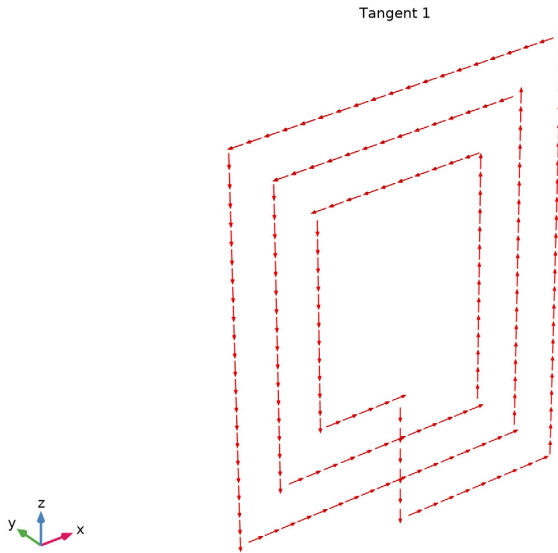

### *Line Integration 1*

- 1 In the **Results** toolbar, click  $8.85 \times 10^{-12}$  **More Derived Values** and choose **Integration > Line Integration**.
- 2 In the **Settings** window for **Line Integration**, locate the **Selection** section.
- 3 From the **Selection** list, choose **Transponder**.
- 4 Locate the **Expressions** section. In the table, enter the following settings:

| Expression                       | Unit | Description       |
|----------------------------------|------|-------------------|
| $(tAx*t1x+tAy*t1y+tAz*t1z)/1[A]$ | nH   | Mutual inductance |

- 5 Click  **Evaluate**.

**TABLE I**

I Go to the **Table I** window.

The result should be close to 0.99 nH.