



Model created in COMSOL Multiphysics 6.4

Permanent Magnet Motor with Campbell Diagram

Introduction

In this modeling example, noise emitted from an electrical motor due to electromagnetic forces is studied. A simplified motor structure is first analyzed to find its natural frequencies and eigenmodes. Following this a time periodic electromagnetic simulation is performed to establish the magnitude and frequency of electromagnetic forces occurring in the motor. Finally the electromagnetic force harmonics are applied as load to determine the resulting structural vibration and surrounding acoustical emission of the motor. From this a Campbell diagram can be generated that provides insight into which harmonics of the electromagnetic forces are causing the most prominent noise.

Model Definition

The focus of this example is on demonstrating the most straightforward way of coupling electromagnetic forces with an acoustic-structural model and postprocessing relevant results. As such a very simple 2D geometry is used for all physics to minimize the level of complexity not directly related to the multiphysics coupling.

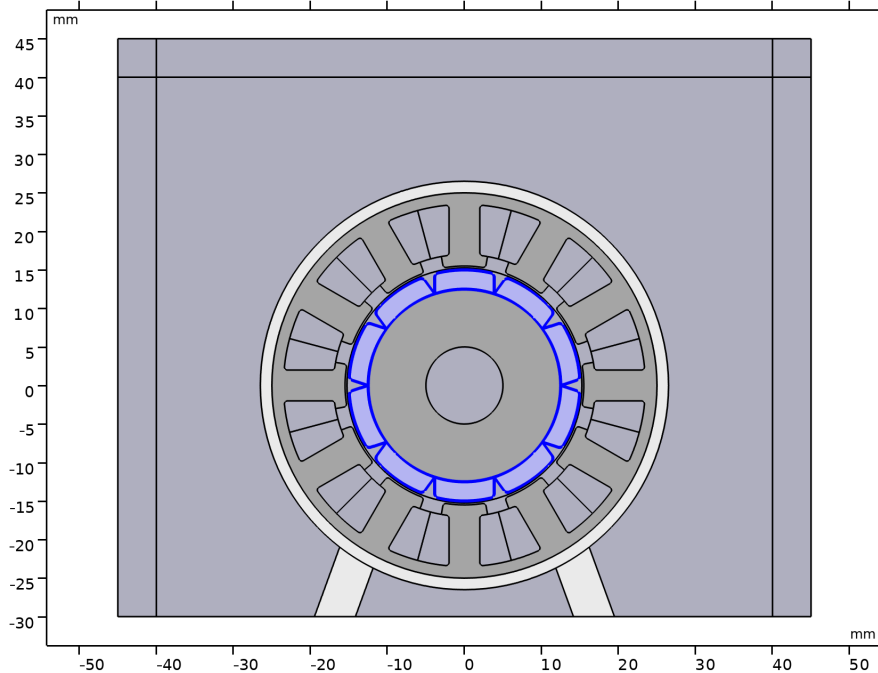

Figure 1: A simple geometry of an electrical motor structure and near surrounding space.

For a more practical case it is normally necessary to model the motor structure and acoustical environment in 3D while electromagnetically a 2D representation can still cover many cases. In such a configuration the main difference from this example would be that the electromagnetic forces are extruded into 3D space with an extrusion coupling operator.

STRUCTURAL CONSIDERATIONS

The Solid Mechanics interface is applied to the stator core, motor housing and foot mounts only.

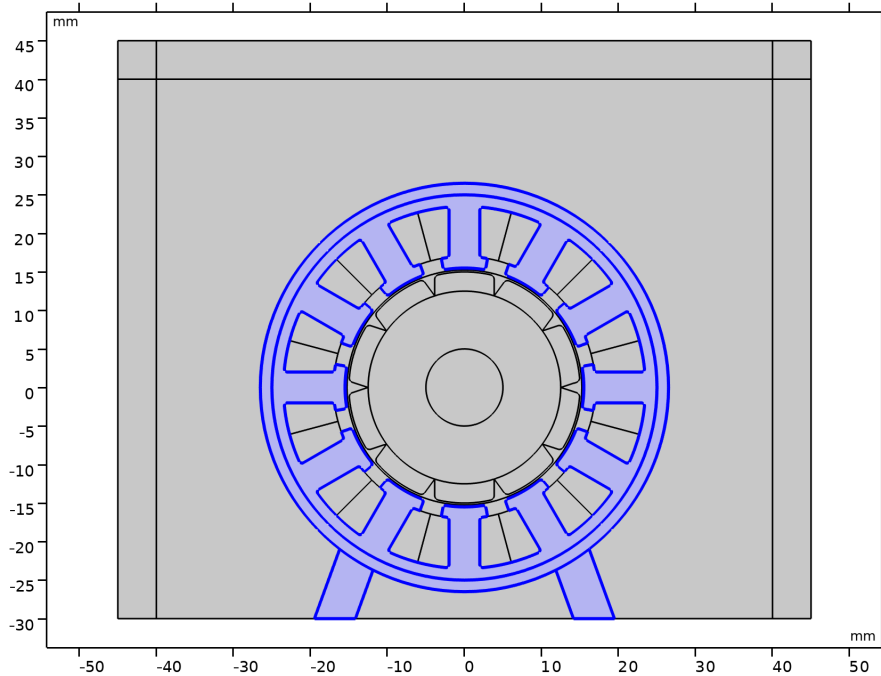

Figure 2: Solid Mechanics domains.

The lower horizontal boundaries of foot mounts are constrained with zero displacement. Electromagnetic forces are applied to all interior boundaries of the stator core.

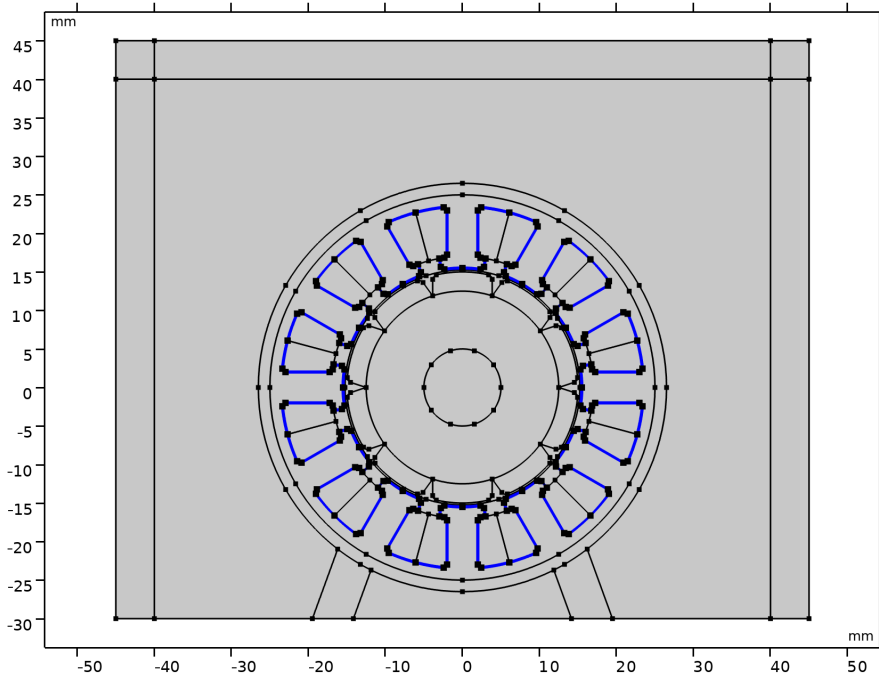

Figure 3: Boundaries at which the electromagnetic forces are applied.

The harmonics of a distributed magnetic force output by the Magnetic Machinery Time Periodic interface can be accessed by calling the Fourier component of the Maxwell surface stress tensor in its operator form. As an example, the x -component can be specified as **mmtp.nTX_I_fft(freq/f_el)**, where **freq** is the swept variable of the frequency domain study and **f_el** is the fundamental electrical frequency. When **freq** is swept over **n** values, all being a multiple of **f_el**, the ratio **freq/f_el** refers to 1st, 2nd, 3rd, ..., **n**th Fourier component of the Maxwell surface stress tensor.

When not doing a sweep over several frequencies, or for other reasons, a specific Fourier component of magnetic force can be accessed directly by using the same variable in its standard form; **mmtp.nTX_I_fft0**, **mmtp.nTX_I_fft1**, **mmtp.nTX_I_fft2**, ..., **mmtp.nTX_I_fftn**, where **n** would be one less half the number of time frames solved for.

ACOUSTICAL CONSIDERATIONS

The acoustical domain in this example is everything outside the motor housing. Perfectly Matched Layer feature is used on outer domains to absorb outgoing wave energy and thus

simulating the emission of acoustic noise in an open space without reflections. On boundaries between the Perfectly Matched Layer and the air surrounding the motor housing, an Exterior Field Calculation is applied in order to calculate the sound pressure level at any distance outside the geometry.

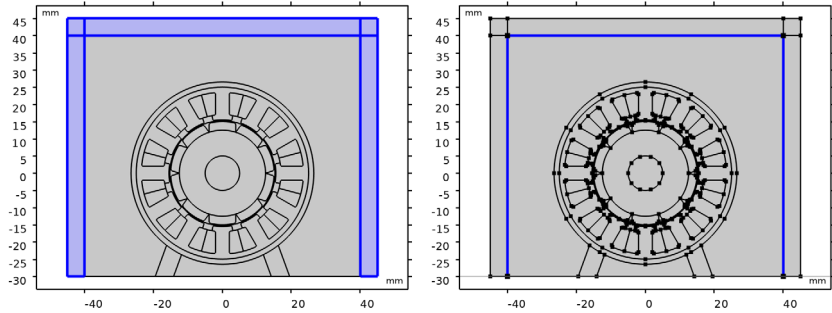

Figure 4: Domains defined by Perfectly Matched Layer and boundaries where Exterior Field Calculation is applied.

The Acoustic-Structure Boundary Multiphysics feature automatically couples the Pressure Acoustics with Solid Mechanics at their common boundaries.

ELECTROMAGNETIC CONSIDERATIONS

Apart from the normal steps of configuring the motor model detailed in step-by-step instructions below, two aspects are highlighted here.

Firstly, in order to generate the computation of Maxwell surface stress tensors a Force Calculation feature must be defined on the domains representing the solid for which boundary forces are required.

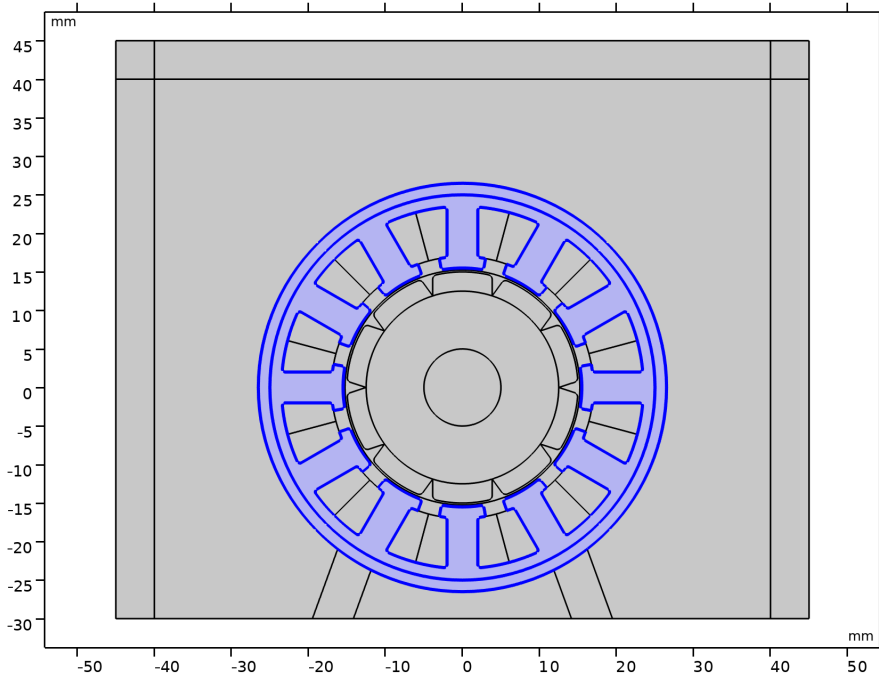

Figure 5: Force Calculation applied to stator core.

The solid components should all be surrounded by air or its equivalent, and not be adjacent to any soft or hard magnetic material. In this case the coils are adjacent stator core but these pose no issue as magnetically they are equivalent to air. A boundary layer mesh is applied to the tips of stator teeth to improve the accuracy of Maxwell surface stress tensor calculation in this area where the magnetic forces are concentrated.

The second matter of extra consideration is the temporal resolution of the electromagnetic simulation. The cogging torque or torque due to reluctance variations as the rotor magnets are passing by stator teeth, will occur on the 12th harmonic of the fundamental electrical frequency.

$$n_{\text{cog}} = \frac{N_s}{\text{gcd}(N_s, N_p)} \cdot 2 \quad (1)$$

Here N_s and N_p are the number of slots and poles, and $\text{gcd}()$ determines the greatest common divisor of these two integers.

In this example it is assumed for the sake of simplicity and moderate solution time that the impact of induced currents is negligible and the electromagnetic part is solved at the nominal current and shaft speed over one electrical period. Resolving the highest frequency of interest, for example the cogging torque, with six time frames ensures sufficient temporal resolution.

In cases where the impact of induced currents is expected to be significant, it would be necessary to ensure that both excitation and induced currents are periodic over the time period solved for. Furthermore, the electromagnetic problem would need to be solved for at all speeds to be investigated.

Results and Discussion

Figure 6 shows the eigenmode of the second natural frequency of the motor structure.

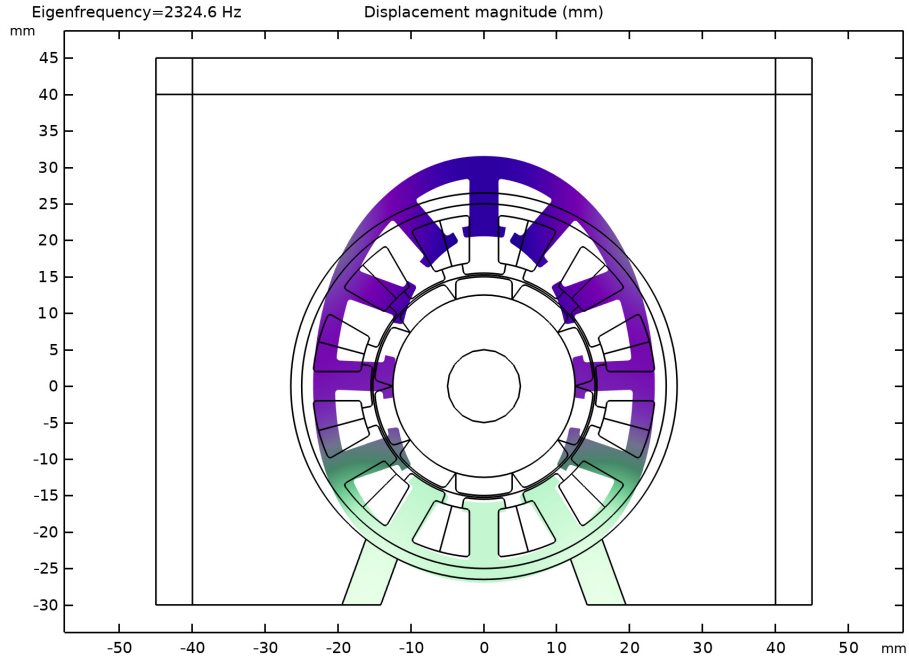

Figure 6: Eigenmode of second natural frequency.

In [Figure 7](#), the 12 first force harmonics are plotted with same scale providing a qualitative comparison. It can be seen the second, fourth and sixth harmonics are the most prominent.

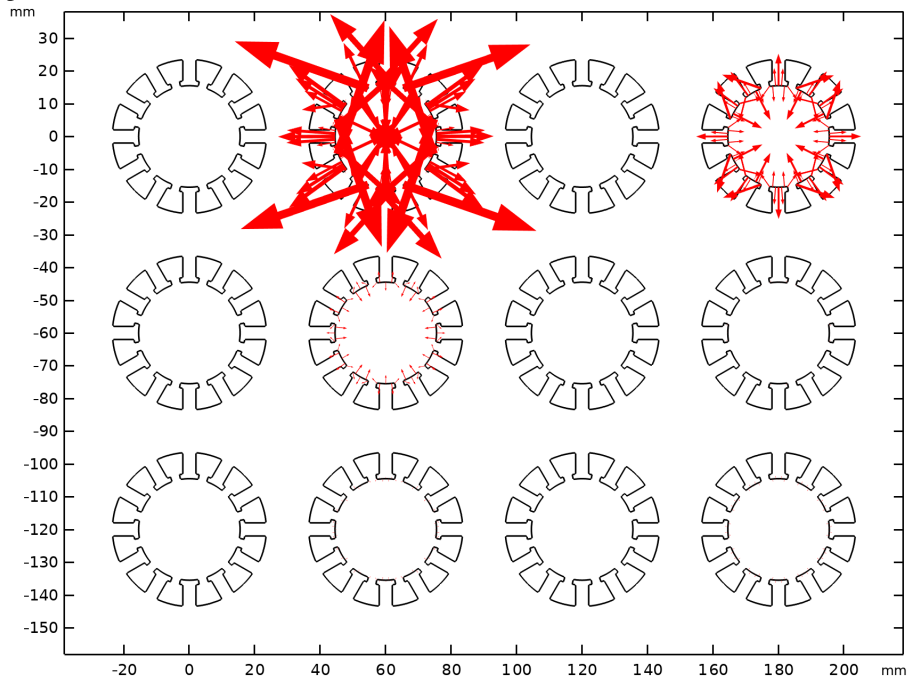

Figure 7: Qualitative evaluation of magnetic force harmonics with the first at top left and 12'th bottom right.

[Figure 8](#) shows the Campbell diagram resulting from the final study. The horizontal lines represent the natural frequencies found in first study. Each of the diagonal lines represent a force harmonic as function of the rotor speed, with the first harmonic to the bottom right. Force harmonics at frequencies below a set limit are not solved for to conserve solution time. The coloring of the diagonal lines represent the sound pressure level measured at point $x = y = 1$ m.

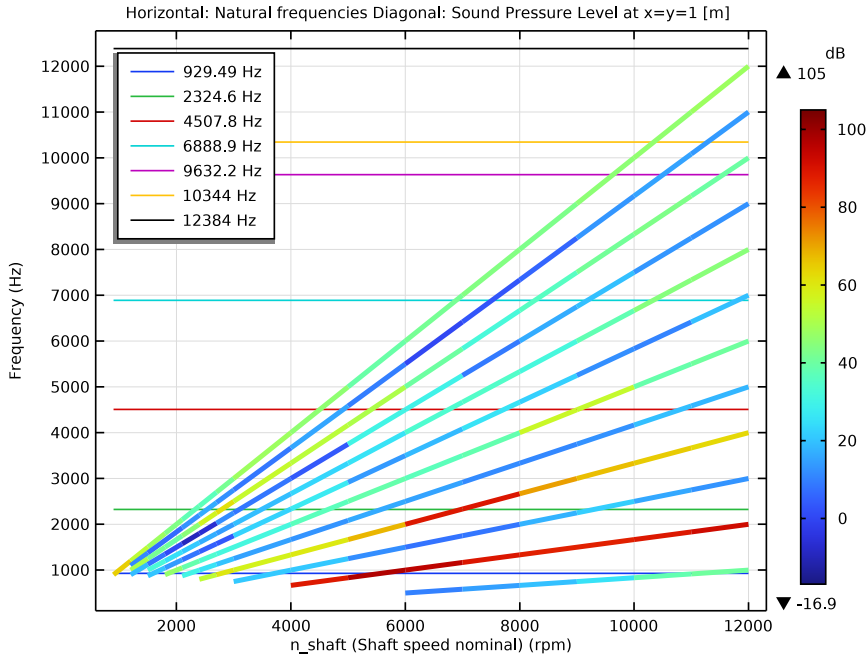

Figure 8: Campbell diagram.

It is clear that the second and fourth are the force harmonics causing the most noise emission. Interestingly the fourth harmonic does not excite the first natural frequency as much as the second, and likewise the sixth harmonic does not excite the second natural frequency as much as the fourth harmonic.

Magnetic forces will have twice the frequency of the magnetic fields that produce them. As such the presence of second and sixth force harmonics are expected being produced by the fundamental electrical frequency and three phase excitation of the stator winding correspondingly. With this understanding the prominence of the fourth harmonic might come as a surprise as it suggests there is a component of the magnetic field varying with twice the fundamental electrical frequency. Although not immediately obvious, one can see this variation on the outer stator core when playing back the animation which is generated at the end of the step-by-step instructions below.

Application Library path: ACDC_Module/Devices,_Motors_and_Generators/
pm_motor_2d_campbell_diagram



Modeling Instructions

From the **File** menu, choose **New**.

NEW

In the **New** window, click  **Model Wizard**.

MODEL WIZARD

- 1 In the **Model Wizard** window, click  **2D**.
- 2 In the **Select Physics** tree, select **Structural Mechanics > Solid Mechanics (solid)**.
- 3 Click **Add**.
- 4 In the **Select Physics** tree, select **Acoustics > Pressure Acoustics > Pressure Acoustics, Frequency Domain (acpr)**.
- 5 Click **Add**.
- 6 In the **Select Physics** tree, select **AC/DC > Electromagnetics and Mechanics > Magnetic Machinery, Rotating, Time Periodic (mmtpr)**.
- 7 Click **Add**.
- 8 Click  **Done**.

GEOMETRY I

- 1 In the **Model Builder** window, under **Component 1 (comp1)** click **Geometry 1**.
- 2 In the **Settings** window for **Geometry**, locate the **Units** section.
- 3 From the **Length unit** list, choose **mm**.
- 4 In the **Geometry** toolbar, click **Insert Sequence** and choose **Insert Sequence**.
- 5 Browse to the model's Application Libraries folder and double-click the file `pm_motor_2d_campbell_diagram_geom_sequence.mph`.
- 6 In the **Geometry** toolbar, click  **Build All**.
- 7 In the **Model Builder** window, collapse the **Geometry 1** node.

GLOBAL DEFINITIONS

Parameters 1

- 1 In the **Model Builder** window, under **Global Definitions** click **Parameters 1**.
- 2 In the **Settings** window for **Parameters**, locate the **Parameters** section.
- 3 In the table, enter the following settings:

Name	Expression	Value	Description
n_shaft	12000[rpm]	200 1/s	Shaft speed nominal
n_cog	$Ns/gcd(Np, Ns) * 2$	12	First cogging harmonic
Nframes	n_cog*6	72	Number of time frames
Ipk	1[A]	1 A	Phase current
init_ang	3.45[rad]	3.45 rad	Initial current angle for peak torque
f_e1	n_shaft*Np/2	1000 1/s	Electrical frequency as function of shaft speed sweep
L	50[mm]	0.05 m	Axial length

DEFINITIONS

Perfectly Matched Layer 1 (pml1)

- 1 In the **Definitions** toolbar, click  **Perfectly Matched Layer**.
- 2 Select Domains 1, 2, 4, 34, and 35 only.
- 3 In the **Settings** window for **Perfectly Matched Layer**, locate the **Scaling** section.
- 4 From the **Physics** list, choose **Pressure Acoustics, Frequency Domain (acpr)**.



Disk 1

- 1 In the **Model Builder** window, under **Component 1 (comp1)** right-click **Definitions** and choose **Selections > Disk**.

Next steps will create a few selections handy for configuring physics and mesh later on.

- 2 In the **Settings** window for **Disk**, locate the **Geometric Entity Level** section.
- 3 From the **Level** list, choose **Boundary**.
- 4 Locate the **Size and Shape** section. In the **Outer radius** text field, type 16.3.
- 5 In the **Inner radius** text field, type 15.1.

Adjacent 1

- 1 In the **Definitions** toolbar, click  **Adjacent**.
- 2 In the **Settings** window for **Adjacent**, locate the **Input Entities** section.
- 3 Under **Input selections**, click  **Add**.
- 4 In the **Add** dialog, select **Stator iron (External Stator – Slotted 1)** in the **Input selections** list.
- 5 Click **OK**.

Disk 2

- 1 In the **Model Builder** window, right-click **Selections** and choose **Disk**.
- 2 In the **Settings** window for **Disk**, locate the **Geometric Entity Level** section.
- 3 From the **Level** list, choose **Boundary**.
- 4 Locate the **Input Entities** section. From the **Entities** list, choose **From selections**.
- 5 Under **Selections**, click  **Add**.
- 6 In the **Add** dialog, select **Adjacent 1** in the **Selections** list.
- 7 Click **OK**.
- 8 In the **Settings** window for **Disk**, locate the **Size and Shape** section.
- 9 In the **Outer radius** text field, type 24.

DEFINITIONS

In the **Model Builder** window, collapse the **Component 1 (comp1) > Definitions** node.

ADD MATERIAL

- 1 In the **Materials** toolbar, click  **Add Material** to open the **Add Material** window.
- 2 Go to the **Add Material** window.
- 3 In the tree, select **Built-in > Air**.
- 4 Click the **Add to Component** button in the window toolbar.
- 5 In the tree, select **Built-in > Steel AISI 4340**.
- 6 Click the **Add to Component** button in the window toolbar.
- 7 In the tree, select **AC/DC > Soft Iron (Without Losses)**.
- 8 Click the **Add to Component** button in the window toolbar.
- 9 In the tree, select **AC/DC > Hard Magnetic Materials > Sintered NdFeB Grades (Chinese Standard) > N42 (Sintered NdFeB)**.
- 10 Click the **Add to Component** button in the window toolbar.

11 In the **Materials** toolbar, click  **Add Material** to close the **Add Material** window.

MATERIALS

Steel AISI 4340 (mat2)

- 1 In the **Settings** window for **Material**, locate the **Geometric Entity Selection** section.
- 2 Click  **Paste Selection**.
- 3 In the **Paste Selection** dialog, type 10, 27, 36 in the **Selection** text field.
- 4 Click **OK**.

Soft Iron (Without Losses) (mat3)

- 1 In the **Model Builder** window, click **Soft Iron (Without Losses) (mat3)**.
- 2 Select Domains 6 and 48 only.
- 3 In the **Settings** window for **Material**, locate the **Material Contents** section.
- 4 In the table, enter the following settings:



Property	Variable	Value	Unit	Property group
Young's modulus	E	185 [GPa]	Pa	Young's modulus and Poisson's ratio
Poisson's ratio	nu	0.3	l	Young's modulus and Poisson's ratio
Density	rho	7500	kg/m ³	Basic

N42 (Sintered NdFeB) (mat4)

The electric conductivity of magnets is zeroed out to exclude any effects of induced currents.

- 1 In the **Model Builder** window, click **N42 (Sintered NdFeB) (mat4)**.
- 2 In the **Settings** window for **Material**, locate the **Geometric Entity Selection** section.
- 3 From the **Selection** list, choose **Rotor Magnets (Internal Rotor – Surface Mounted Magnets 1)**.
- 4 Locate the **Material Contents** section. In the table, enter the following settings:

Property	Variable	Value	Unit	Property group
Electric conductivity	sigma_iso ; sigma_ii = sigma_iso, sigma_ij = 0	0*1 / 1.4 [uohm *m]	S/m	Basic

- 5 Click the  **Colors** button in the **Graphics** toolbar.
- 6 In the **Graphics** window toolbar, click  next to  **Colors**, then choose **Show Material Color and Texture**.

SOLID MECHANICS (SOLID)

- 1 In the **Model Builder** window, under **Component 1 (comp1)** click **Solid Mechanics (solid)**.
- 2 In the **Settings** window for **Solid Mechanics**, locate the **Domain Selection** section.
- 3 From the **Selection** list, choose **Structural domains**.
- 4 Locate the **Thickness** section. In the d text field, type L.

Fixed Constraint 1

- 1 In the **Physics** toolbar, click  **Boundaries** and choose **Fixed Constraint**.
- 2 Select Boundaries 18 and 66 only.

PRESSURE ACOUSTICS, FREQUENCY DOMAIN (ACPR)

- 1 In the **Model Builder** window, under **Component 1 (comp1)** click **Pressure Acoustics, Frequency Domain (acpr)**.
- 2 In the **Settings** window for **Pressure Acoustics, Frequency Domain**, locate the **Domain Selection** section.
- 3 From the **Selection** list, choose **Acoustic domains**.

Exterior Field Calculation 1

- 1 In the **Physics** toolbar, click  **Boundaries** and choose **Exterior Field Calculation**.
- 2 Select Boundaries 6, 9, and 79 only.
- 3 In the **Settings** window for **Exterior Field Calculation**, locate the **Exterior Field Calculation** section.
- 4 From the **Condition in the $y = y_0$ plane** list, choose **Symmetric/Infinite sound hard boundary**.
- 5 In the y_0 text field, type -30[mm].

MAGNETIC MACHINERY, ROTATING, TIME PERIODIC (MMTP)

- 1 In the **Model Builder** window, under **Component 1 (comp1)** click **Magnetic Machinery, Rotating, Time Periodic (mmtpr)**.
- 2 In the **Settings** window for **Magnetic Machinery, Rotating, Time Periodic**, locate the **Domain Selection** section.
- 3 From the **Selection** list, choose **Electromagnetic domains**.

- 4 Locate the **Thickness** section. In the d text field, type L.
- 5 Locate the **Time Periodic Settings** section. In the f_{TP} text field, type f_e .
- 6 In the n_{TP} text field, type N_f frames.
- 7 Locate the **Motion Settings** section. In the n_{poles} text field, type N_p .

Rotational Magnetic Continuity I

In the **Physics** toolbar, click  **Pairs** and choose **Rotational Magnetic Continuity**.

Rotating Domain I

The Rotating Domain feature will by default select all domains on one side of the Rotational Continuity Pair, which in this case are the rotor domains as wanted. Further the default Time periodic rotation will ensure rotation through an angle corresponding to a pole pair or one period of the fundamental electrical frequency.

In the **Physics** toolbar, click  **Domains** and choose **Rotating Domain**.

Passive Conductor I

- 1 In the **Physics** toolbar, click  **Domains** and choose **Passive Conductor**.
- 2 Select Domain 36 only.

Laminated Core I

- 1 In the **Physics** toolbar, click  **Domains** and choose **Laminated Core**.
- 2 Select Domains 6 and 48 only.

Magnet I

- 1 In the **Physics** toolbar, click  **Domains** and choose **Magnet**.
- 2 In the **Settings** window for **Magnet**, locate the **Domain Selection** section.
- 3 From the **Selection** list, choose **Rotor Magnets (Internal Rotor – Surface Mounted Magnets I)**.
- 4 Locate the **Magnet** section. From the **Pattern type** list, choose **Circular pattern**.
- 5 From the **Type of periodicity** list, choose **Alternating**.

North I

- 1 In the **Model Builder** window, expand the **Magnet I** node, then click **North I**.
- 2 Select Boundary 345 only.

South I

- 1 In the **Model Builder** window, click **South I**.
- 2 Select Boundary 342 only.

Multiphase Winding 1

- 1 In the **Physics** toolbar, click  **Domains** and choose **Multiphase Winding**.
- 2 In the **Settings** window for **Multiphase Winding**, locate the **Domain Selection** section.
- 3 From the **Selection** list, choose **Stator slots (External Stator – Slotted 1)**.
- 4 Locate the **Multiphase Winding** section. In the I_{pk} text field, type I_{pk} .
- 5 In the α_1 text field, type `init_ang`.



The default Winding electrical frequency corresponds with the frequency of the Magnetic Machinery Time Periodic interface which is what is intended in this example. If solving for a longer period however, the Winding electrical frequency can be set explicitly here.

- 6 From the **Winding layout configuration** list, choose **Automatic three phase**.
- 7 In the n_{slots} text field, type N_s .
- 8 Click **Add Phases**.

Force Calculation 1

- 1 In the **Physics** toolbar, click  **Domains** and choose **Force Calculation**.
- 2 Select Domains 6 and 36 only.

ADD MULTIPHYSICS

- 1 In the **Home** toolbar, click  **Add Multiphysics** to open the **Add Multiphysics** window.
- 2 Go to the **Add Multiphysics** window.
- 3 In the tree, select **No Predefined Multiphysics Available for the Selected Physics Interfaces**.
- 4 Find the **Select the physics interfaces you want to couple** subsection. In the table, clear the **Couple** checkbox for **Magnetic Machinery, Rotating, Time Periodic (mmtp)**.
- 5 In the tree, select **Acoustics > Acoustic–Structure Interaction > Acoustic–Solid Interaction, Frequency Domain**.
- 6 Click the **Add to Component** button in the window toolbar.
- 7 In the **Home** toolbar, click  **Add Multiphysics** to close the **Add Multiphysics** window.

MESH 1

- 1 In the **Settings** window for **Mesh**, locate the **Physics-Controlled Mesh** section.
- 2 In the table, clear the **Use** checkbox for **Pressure Acoustics, Frequency Domain (acpr)**.
- 3 Right-click **Component 1 (comp1) > Mesh 1** and choose **Edit Physics-Induced Sequence**.

Size



- 1 In the **Model Builder** window, under **Component 1 (comp1) > Mesh 1** click **Size**.

- 2 In the **Settings** window for **Size**, locate the **Element Size** section.
- 3 Click the **Custom** button.
- 4 Locate the **Element Size Parameters** section. In the **Maximum element size** text field, type 2.5.
- 5 In the **Curvature factor** text field, type 0.5.
- 6 In the **Resolution of narrow regions** text field, type 0.3.

Size 1

- 1 In the **Model Builder** window, right-click **Mesh 1** and choose **Size**.
- 2 Drag and drop **Size 1** below **Size**.
- 3 In the **Settings** window for **Size**, locate the **Geometric Entity Selection** section.
- 4 From the **Geometric entity level** list, choose **Domain**.
- 5 Select Domain 6 only.
- 6 Locate the **Element Size** section. Click the **Custom** button.
- 7 Locate the **Element Size Parameters** section.
- 8 Select the **Maximum element size** checkbox. In the associated text field, type 0.7.

Free Triangular 1

- 1 In the **Model Builder** window, click **Free Triangular 1**.
- 2 In the **Settings** window for **Free Triangular**, locate the **Domain Selection** section.
- 3 Click  **Paste Selection**.
- 4 In the **Paste Selection** dialog, type 3,5-15,17-33,36-49 in the **Selection** text field.
- 5 Click **OK**.
- 6 In the **Settings** window for **Free Triangular**, click  **Build All**.

Boundary Layers 1

- 1 In the **Mesh** toolbar, click  **Boundary Layers**.
- 2 In the **Settings** window for **Boundary Layers**, locate the **Domain Selection** section.
- 3 From the **Geometric entity level** list, choose **Domain**.
- 4 Select Domains 3, 13, and 37 only.
- 5 Click to expand the **Transition** section. Clear the **Smooth transition to interior mesh** checkbox.

Boundary Layer Properties

- 1 In the **Model Builder** window, click **Boundary Layer Properties**.

- 2 In the **Settings** window for **Boundary Layer Properties**, locate the **Boundary Selection** section.
- 3 From the **Selection** list, choose **Disk I**.
- 4 Locate the **Layers** section. In the **Number of layers** text field, type 1.
- 5 In the **Thickness adjustment factor** text field, type 5.

Boundary Layer Properties I

- 1 In the **Mesh** toolbar, click  **More Attributes** and choose **Boundary Layer Properties**.
- 2 Select Boundaries 6, 9, and 79 only.
- 3 In the **Settings** window for **Boundary Layer Properties**, locate the **Layers** section.
- 4 In the **Number of layers** text field, type 1.
- 5 In the **Thickness adjustment factor** text field, type 5.

Mapped I

- 1 In the **Mesh** toolbar, click  **Mapped**.
- 2 In the **Settings** window for **Mapped**, locate the **Domain Selection** section.
- 3 From the **Geometric entity level** list, choose **Domain**.
- 4 Select Domains 1, 2, 4, 34, and 35 only.

Distribution I

- 1 Right-click **Mapped I** and choose **Distribution**.
- 2 Select Boundaries 4, 8, and 82 only.
- 3 In the **Settings** window for **Distribution**, locate the **Distribution** section.
- 4 In the **Number of elements** text field, type 8.
- 5 Click  **Build All**.

MESH I

In the **Model Builder** window, collapse the **Component I (comp1) > Mesh I** node.

ADD STUDY

- 1 In the **Home** toolbar, click  **Add Study** to open the **Add Study** window.
- 2 Go to the **Add Study** window.
- 3 Find the **Studies** subsection. In the **Select Study** tree, select **Preset Studies for Some Physics Interfaces > Eigenfrequency**.
- 4 Click the **Add Study** button in the window toolbar.
- 5 In the **Select Study** tree, select **Preset Studies for Some Physics Interfaces > Stationary**.

- 6 Click the **Add Study** button in the window toolbar.
- 7 In the **Select Study** tree, select **General Studies > Frequency Domain**.
- 8 Click the **Add Study** button in the window toolbar.
- 9 In the **Home** toolbar, click  **Add Study** to close the **Add Study** window.

STUDY 1 - STRUCTURAL MODES

In the **Settings** window for **Study**, type Study 1 - Structural Modes in the **Label** text field.

Step 1: Eigenfrequency

- 1 In the **Model Builder** window, under **Study 1 - Structural Modes** click **Step 1: Eigenfrequency**.
- 2 In the **Settings** window for **Eigenfrequency**, locate the **Study Settings** section.
- 3 Select the **Desired number of eigenfrequencies** checkbox. In the associated text field, type 7.
- 4 Clear the **Search for eigenfrequencies around shift** checkbox.
- 5 Locate the **Physics and Variables Selection** section. In the **Solve for** column of the table, under **Component 1 (comp1)**, clear the checkbox for **Pressure Acoustics, Frequency Domain (acpr)**.
- 6 In the **Solve for** column of the table, under **Component 1 (comp1) > Multiphysics**, clear the checkbox for **Acoustic-Structure Boundary 1 (asb1)**.
- 7 In the **Study** toolbar, click  **Compute**.

RESULTS

Mode Shape (solid)

In the **Settings** window for **2D Plot Group**, click  **Plot Next**.

GLOBAL DEFINITIONS

Parameters 1

- 1 In the **Model Builder** window, under **Global Definitions** click **Parameters 1**.
- 2 In the **Settings** window for **Parameters**, locate the **Parameters** section.
- 3 In the table, enter the following settings:

Name	Expression	Value	Description
freq_min	900[Hz]	900 Hz	Threshold frequency for sweep

STUDY 2 - ELECTROMAGNETIC FORCES

- 1 In the **Model Builder** window, click **Study 2**.
- 2 In the **Settings** window for **Study**, type Study 2 - Electromagnetic Forces in the **Label** text field.

Step 1: Stationary

- 1 In the **Model Builder** window, under **Study 2 - Electromagnetic Forces** click **Step 1: Stationary**.
- 2 In the **Settings** window for **Stationary**, locate the **Physics and Variables Selection** section.
- 3 In the **Solve for** column of the table, under **Component 1 (comp1)**, clear the checkbox for **Solid Mechanics (solid)**.
- 4 In the **Study** toolbar, click  **Compute**.

SOLID MECHANICS (SOLID)

Boundary Load 1

- 1 In the **Physics** toolbar, click  **Boundaries** and choose **Boundary Load**.
- 2 In the **Settings** window for **Boundary Load**, locate the **Boundary Selection** section.
- 3 From the **Selection** list, choose **Disk 2**.
- 4 Locate the **Force** section. Specify the \mathbf{f}_A vector as

$\text{mmt.p.nTX}_1\text{_fft}(\text{freq}/\text{f_e1})$	x
$\text{mmt.p.nTY}_1\text{_fft}(\text{freq}/\text{f_e1})$	y

STUDY 3 - VIBRATIONS AND NOISE

After having coupled the magnetic forces as a load in Solid Mechanics it is time to configure the final study to solve for the structural vibrations and acoustical noise for each force harmonic. Generally if the electromagnetic forces are dependent on rotor speed and contrary to this example, the Magnetic Machinery physics would be directly included in the following study (which makes away with Study 2).

- 1 In the **Model Builder** window, click **Study 3**.
- 2 In the **Settings** window for **Study**, type Study 3 - Vibrations and Noise in the **Label** text field.

Step 1: Frequency Domain

- 1 In the **Model Builder** window, under **Study 3 - Vibrations and Noise** click **Step 1: Frequency Domain**.

- 2 In the **Settings** window for **Frequency Domain**, locate the **Physics and Variables Selection** section.
- 3 In the **Solve for** column of the table, under **Component 1 (comp1)**, clear the checkbox for **Magnetic Machinery, Rotating, Time Periodic (mmtp)**.
- 4 Click to expand the **Values of Dependent Variables** section. Find the **Values of variables not solved for** subsection. From the **Settings** list, choose **User controlled**.
- 5 From the **Method** list, choose **Solution**.
- 6 From the **Study** list, choose **Study 2 - Electromagnetic Forces, Stationary**.

Parametric Sweep

- 1 In the **Study** toolbar, click  **Parametric Sweep**.
- 2 In the **Settings** window for **Parametric Sweep**, locate the **Study Settings** section.
- 3 Click **+ Add**.

The range of rotor speeds is configured to have a finer resolution at the lower end where most of the higher force harmonics are passing through the first natural frequencies.

- 4 In the table, enter the following settings:

Parameter name	Parameter value list	Parameter unit
n_shaft (Shaft speed nominal)	range(900,300,3000) range(4000,1000,12000)	rpm

- 5 Click to expand the **Advanced Settings** section. Select the **Reuse solution from previous step** checkbox.

Step 1: Frequency Domain

Instead of solving for all harmonics at all rotor speeds, it is possible to restrict the frequencies solved for to the ones that reach above a certain level, here `freq_min`. Typically, the lower harmonics do not reach the natural frequencies until higher speeds. If they are deemed uninteresting, they can be excluded from the analysis as follows.

- 1 In the **Model Builder** window, click **Step 1: Frequency Domain**.
- 2 In the **Settings** window for **Frequency Domain**, locate the **Study Settings** section.
- 3 In the **Frequencies** text field, type `range(12, -1, floor(max(freq_min/f_el, 1))) * f_el`.
- 4 In the **Study** toolbar, click  **Compute**.

RESULTS

Campbell diagram

- 1 In the **Results** toolbar, click  **ID Plot Group**.
- 2 In the **Settings** window for **ID Plot Group**, type **Campbell diagram** in the **Label** text field.

Line Segments

- 1 Right-click **Campbell diagram** and choose **Line Segments**.
- 2 In the **Settings** window for **Line Segments**, locate the **x-Coordinates** section.
- 3 In the table, enter the following settings:

Expression	Unit	Description
900	1	
12000	1	

- 4 Click **Add Expression** in the upper-right corner of the **y-Coordinates** section. From the menu, choose **Component 1 (comp1) > Solid Mechanics > Global > solid.freq - Frequency - Hz**.
- 5 Click **Add Expression** in the upper-right corner of the **y-Coordinates** section. From the menu, choose **solid.freq - Frequency - Hz**.
- 6 Click to expand the **Title** section. From the **Title type** list, choose **Manual**.
- 7 In the **Title** text area, type **Horizontal: Natural frequencies**.
- 8 Click to expand the **Legends** section. Select the **Show legends** checkbox.

Global

- 1 In the **Model Builder** window, right-click **Campbell diagram** and choose **Global**.
- 2 In the **Settings** window for **Global**, locate the **Data** section.
- 3 From the **Dataset** list, choose **Study 3 - Vibrations and Noise/ Parametric Solutions 1 (sol4)**.
- 4 Click **Add Expression** in the upper-right corner of the **y-Axis Data** section. From the menu, choose **Component 1 (comp1) > Solid Mechanics > Global > solid.freq - Frequency - Hz**.
- 5 Locate the **x-Axis Data** section. From the **Axis source data** list, choose **Outer solutions**.
- 6 Click to expand the **Coloring and Style** section. From the **Width** list, choose **3**.
- 7 Click to expand the **Legends** section. Clear the **Show legends** checkbox.

Color Expression 1

- 1 Right-click **Global 1** and choose **Color Expression**.
- 2 In the **Settings** window for **Color Expression**, locate the **Expression** section.
- 3 In the **Expression** text field, type `subst(acpr.efc1.Lp_pext,x,1[m],y,1[m])`.
- 4 From the **Unit** list, choose **dB**.

Campbell diagram

- 1 In the **Model Builder** window, under **Results** click **Campbell diagram**.
- 2 In the **Settings** window for **ID Plot Group**, locate the **Legend** section.
- 3 From the **Position** list, choose **Upper left**.
- 4 Locate the **Color Legend** section. Select the **Show maximum and minimum values** checkbox.
- 5 Select the **Show units** checkbox.
- 6 In the **Campbell diagram** toolbar, click  **Plot**.

Global 1

- 1 In the **Model Builder** window, click **Global 1**.
- 2 In the **Settings** window for **Global**, click to expand the **Title** section.
- 3 From the **Title type** list, choose **Manual**.
- 4 In the **Title** text area, type `Diagonal: Sound Pressure Level at x=y=1 [m]`.
- 5 In the **Campbell diagram** toolbar, click  **Plot**.

Configure the default Exterior-Field plots to evaluate noise from the fourth harmonic of the electromagnetic forces at a rotational speed of 7000 rpm and at a radius of 1 m.

Exterior-Field Sound Pressure Level (acpr)

- 1 In the **Model Builder** window, under **Results** click **Exterior-Field Sound Pressure Level (acpr)**.
- 2 In the **Settings** window for **Polar Plot Group**, locate the **Data** section.
- 3 From the **Parameter selection (n_shaft)** list, choose **From list**.
- 4 In the **Parameter values (n_shaft (rpm))** list box, select **7000**.
- 5 From the **Parameter selection (freq)** list, choose **Manual**.
- 6 In the **Parameter indices (1-12)** text field, type **9**.
- 7 Locate the **Axis** section. From the **Zero angle** list, choose **Up**.

Radiation Pattern I

- 1 In the **Model Builder** window, expand the **Exterior-Field Sound Pressure Level (acpr)** node, then click **Radiation Pattern I**.
- 2 In the **Settings** window for **Radiation Pattern**, locate the **Evaluation** section.
- 3 Find the **Angles** subsection. From the **Restriction** list, choose **Manual**.
- 4 In the ϕ **start** text field, type -90.
- 5 In the ϕ **range** text field, type 180.
- 6 Find the **Circle** subsection. From the **Circle** list, choose **Manual**.
- 7 Find the **Evaluation distance** subsection. In the **Radius** text field, type 1 [m].
- 8 In the **Exterior-Field Sound Pressure Level (acpr)** toolbar, click  **Plot**.

Exterior-Field Pressure (acpr)

- 1 In the **Model Builder** window, under **Results** click **Exterior-Field Pressure (acpr)**.
- 2 In the **Settings** window for **Polar Plot Group**, locate the **Data** section.
- 3 From the **Parameter selection (n_shaft)** list, choose **From list**.
- 4 In the **Parameter values (n_shaft (rpm))** list box, select **7000**.
- 5 From the **Parameter selection (freq)** list, choose **Manual**.
- 6 In the **Parameter indices (1-12)** text field, type 9.
- 7 Locate the **Axis** section. From the **Zero angle** list, choose **Up**.

Radiation Pattern I

- 1 In the **Model Builder** window, expand the **Exterior-Field Pressure (acpr)** node, then click **Radiation Pattern I**.
- 2 In the **Settings** window for **Radiation Pattern**, locate the **Evaluation** section.
- 3 Find the **Angles** subsection. From the **Restriction** list, choose **Manual**.
- 4 In the ϕ **start** text field, type -90.
- 5 In the ϕ **range** text field, type 180.
- 6 Find the **Circle** subsection. From the **Circle** list, choose **Manual**.
- 7 Find the **Evaluation distance** subsection. In the **Radius** text field, type 1 [m].
- 8 In the **Exterior-Field Pressure (acpr)** toolbar, click  **Plot**.

Magnetic Flux Density Norm (mmtp)

In the following a few modifications to the default plot of magnetic flux density are made to shorten time taken to generate animation.

Surface 1

- 1 In the **Model Builder** window, expand the **Magnetic Flux Density Norm (mmtp)** node, then click **Surface 1**.
- 2 In the **Settings** window for **Surface**, click **Replace Expression** in the upper-right corner of the **Expression** section. From the menu, choose **Component 1 (comp1) > Magnetic Machinery, Rotating, Time Periodic > Magnetic > mmtp.normB_tpph - Magnetic flux density norm, function of phase - T**.



Streamline 1

In the **Model Builder** window, right-click **Streamline 1** and choose **Disable**.

Contour 1

- 1 In the **Model Builder** window, click **Contour 1**.
- 2 In the **Settings** window for **Contour**, click **Replace Expression** in the upper-right corner of the **Expression** section. From the menu, choose **Component 1 (comp1) > Magnetic Machinery, Rotating, Time Periodic > Magnetic > mmtp.AZ_tpph - Magnetic vector potential out of plane, function of phase - Wb/m**.

Animation 1

- 1 In the **Magnetic Flux Density Norm (mmtp)** toolbar, click  **Animation** and choose **Player**.
- 2 In the **Settings** window for **Animation**, locate the **Animation Editing** section.
- 3 From the **Sequence type** list, choose **Dynamic data extension**.
- 4 Locate the **Frames** section. In the **Number of frames** text field, type 36.
- 5 Locate the **Playing** section. From the **Repeat** list, choose **Number of iterations**.
- 6 In the **Number of iterations** text field, type 5.
- 7 Click to expand the **Advanced** section. Clear the **Synchronize scales between frames** checkbox.
- 8 Click the  **Play** button in the **Graphics** toolbar.

Magnetic force harmonics

The remainder of these instructions is a rather repetitive set of steps in order to reproduce Figure 7 in the Results and Discussion section, and is provided here for reference.

- 1 In the **Results** toolbar, click  **2D Plot Group**.
- 2 In the **Settings** window for **2D Plot Group**, type Magnetic force harmonics in the **Label** text field.

- 3 Locate the **Data** section. From the **Dataset** list, choose **Study 2 - Electromagnetic Forces/ Solution 2 (sol2)**.
- 4 Locate the **Plot Settings** section. Clear the **Plot dataset edges** checkbox.

Line 1

- 1 Right-click **Magnetic force harmonics** and choose **Line**.
- 2 In the **Settings** window for **Line**, locate the **Expression** section.
- 3 In the **Expression** text field, type 1.
- 4 Click to expand the **Title** section. From the **Title type** list, choose **None**.
- 5 Locate the **Coloring and Style** section. From the **Coloring** list, choose **Uniform**.
- 6 From the **Color** list, choose **From theme**.

Selection 1

- 1 Right-click **Line 1** and choose **Selection**.
- 2 In the **Settings** window for **Selection**, locate the **Selection** section.
- 3 From the **Selection** list, choose **Disk 2**.

Arrow Line 1

- 1 In the **Model Builder** window, right-click **Magnetic force harmonics** and choose **Arrow Line**.
- 2 In the **Settings** window for **Arrow Line**, locate the **Expression** section.
- 3 In the **X-component** text field, type `mmtp.nTX_1_fft1`.
- 4 In the **Y-component** text field, type `mmtp.nTY_1_fft1`.
- 5 Click to expand the **Title** section. From the **Title type** list, choose **None**.
- 6 Locate the **Arrow Positioning** section. In the **Number of arrows** text field, type 2000.

Arrow Line 1, Line 1

- 1 In the **Model Builder** window, under **Results > Magnetic force harmonics**, Ctrl-click to select **Line 1** and **Arrow Line 1**.
- 2 Right-click and choose **Duplicate**.

Transformation 1

- 1 In the **Model Builder** window, right-click **Line 2** and choose **Transformation**.
- 2 In the **Settings** window for **Transformation**, locate the **Transformation** section.
- 3 In the **X** text field, type 60.

Arrow Line 2

- 1 In the **Model Builder** window, under **Results > Magnetic force harmonics** click **Arrow Line 2**.
- 2 In the **Settings** window for **Arrow Line**, locate the **Expression** section.
- 3 In the **X-component** text field, type `mmtp.nTX_1_fft2`.
- 4 In the **Y-component** text field, type `mmtp.nTY_1_fft2`.
- 5 Click to expand the **Inherit Style** section. From the **Plot** list, choose **Arrow Line 1**.

Transformation 1

- 1 Right-click **Arrow Line 2** and choose **Transformation**.
- 2 In the **Settings** window for **Transformation**, locate the **Transformation** section.
- 3 In the **X** text field, type 60.

Arrow Line 2, Line 2

- 1 In the **Model Builder** window, under **Results > Magnetic force harmonics**, Ctrl-click to select **Line 2** and **Arrow Line 2**.
- 2 Right-click and choose **Duplicate**.

Transformation 1

- 1 In the **Model Builder** window, expand the **Results > Magnetic force harmonics > Line 3** node, then click **Transformation 1**.
- 2 In the **Settings** window for **Transformation**, locate the **Transformation** section.
- 3 In the **X** text field, type 120.

Arrow Line 3

- 1 In the **Model Builder** window, under **Results > Magnetic force harmonics** click **Arrow Line 3**.
- 2 In the **Settings** window for **Arrow Line**, locate the **Expression** section.
- 3 In the **X-component** text field, type `mmtp.nTX_1_fft3`.
- 4 In the **Y-component** text field, type `mmtp.nTY_1_fft3`.

Transformation 1

- 1 In the **Model Builder** window, expand the **Arrow Line 3** node, then click **Transformation 1**.
- 2 In the **Settings** window for **Transformation**, locate the **Transformation** section.
- 3 In the **X** text field, type 120.

Arrow Line 3, Line 3

- 1 In the **Model Builder** window, under **Results > Magnetic force harmonics**, Ctrl-click to select **Line 3** and **Arrow Line 3**.
- 2 Right-click and choose **Duplicate**.

Transformation 1

- 1 In the **Model Builder** window, expand the **Results > Magnetic force harmonics > Line 4** node, then click **Transformation 1**.
- 2 In the **Settings** window for **Transformation**, locate the **Transformation** section.
- 3 In the **X** text field, type 180.

Arrow Line 4

- 1 In the **Model Builder** window, under **Results > Magnetic force harmonics** click **Arrow Line 4**.
- 2 In the **Settings** window for **Arrow Line**, locate the **Expression** section.
- 3 In the **X-component** text field, type mmtp.nTX_1_fft4 .
- 4 In the **Y-component** text field, type mmtp.nTY_1_fft4 .

Transformation 1

- 1 In the **Model Builder** window, expand the **Arrow Line 4** node, then click **Transformation 1**.
- 2 In the **Settings** window for **Transformation**, locate the **Transformation** section.
- 3 In the **X** text field, type 180.

Arrow Line 4, Line 4

- 1 In the **Model Builder** window, under **Results > Magnetic force harmonics**, Ctrl-click to select **Line 4** and **Arrow Line 4**.
- 2 Right-click and choose **Duplicate**.

Transformation 1

- 1 In the **Model Builder** window, expand the **Results > Magnetic force harmonics > Line 5** node, then click **Transformation 1**.
- 2 In the **Settings** window for **Transformation**, locate the **Transformation** section.
- 3 In the **X** text field, type 0.
- 4 In the **Y** text field, type -60.

Arrow Line 5

- 1 In the **Model Builder** window, under **Results > Magnetic force harmonics** click **Arrow Line 5**.

- 2 In the **Settings** window for **Arrow Line**, locate the **Expression** section.
- 3 In the **X-component** text field, type `mmtp.nTX_1_ffft5`.
- 4 In the **Y-component** text field, type `mmtp.nTY_1_ffft5`.
- 5 Click the  **Zoom Extents** button in the **Graphics** toolbar.

Transformation 1

- 1 In the **Model Builder** window, expand the **Arrow Line 5** node, then click **Transformation 1**.
- 2 In the **Settings** window for **Transformation**, locate the **Transformation** section.
- 3 In the **X** text field, type 0.
- 4 In the **Y** text field, type -60.

Arrow Line 5

Click the  **Zoom Extents** button in the **Graphics** toolbar.

Arrow Line 5, Line 5

- 1 In the **Model Builder** window, under **Results > Magnetic force harmonics**, Ctrl-click to select **Line 5** and **Arrow Line 5**.
- 2 Right-click and choose **Duplicate**.

Transformation 1

- 1 In the **Model Builder** window, expand the **Results > Magnetic force harmonics > Line 6** node, then click **Transformation 1**.
- 2 In the **Settings** window for **Transformation**, locate the **Transformation** section.
- 3 In the **X** text field, type 60.

Arrow Line 6

- 1 In the **Model Builder** window, under **Results > Magnetic force harmonics** click **Arrow Line 6**.
- 2 In the **Settings** window for **Arrow Line**, locate the **Expression** section.
- 3 In the **X-component** text field, type `mmtp.nTX_1_ffft6`.
- 4 In the **Y-component** text field, type `mmtp.nTY_1_ffft6`.

Transformation 1

- 1 In the **Model Builder** window, expand the **Arrow Line 6** node, then click **Transformation 1**.
- 2 In the **Settings** window for **Transformation**, locate the **Transformation** section.
- 3 In the **X** text field, type 60.

Arrow Line 6, Line 6

- 1 In the **Model Builder** window, under **Results > Magnetic force harmonics**, Ctrl-click to select **Line 6** and **Arrow Line 6**.
- 2 Right-click and choose **Duplicate**.

Transformation 1

- 1 In the **Model Builder** window, expand the **Results > Magnetic force harmonics > Line 7** node, then click **Transformation 1**.
- 2 In the **Settings** window for **Transformation**, locate the **Transformation** section.
- 3 In the **X** text field, type 120.

Arrow Line 7

- 1 In the **Model Builder** window, under **Results > Magnetic force harmonics** click **Arrow Line 7**.
- 2 In the **Settings** window for **Arrow Line**, locate the **Expression** section.
- 3 In the **X-component** text field, type `mmtp.nTX_1_fft7`.
- 4 In the **Y-component** text field, type `mmtp.nTY_1_fft7`.
- 5 Click the  **Zoom Extents** button in the **Graphics** toolbar.

Transformation 1

- 1 In the **Model Builder** window, expand the **Arrow Line 7** node, then click **Transformation 1**.
- 2 In the **Settings** window for **Transformation**, locate the **Transformation** section.
- 3 In the **X** text field, type 120.

Arrow Line 7, Line 7

- 1 In the **Model Builder** window, under **Results > Magnetic force harmonics**, Ctrl-click to select **Line 7** and **Arrow Line 7**.
- 2 Right-click and choose **Duplicate**.

Transformation 1

- 1 In the **Model Builder** window, expand the **Results > Magnetic force harmonics > Line 8** node, then click **Transformation 1**.
- 2 In the **Settings** window for **Transformation**, locate the **Transformation** section.
- 3 In the **X** text field, type 180.

Arrow Line 8

- 1 In the **Model Builder** window, under **Results > Magnetic force harmonics** click **Arrow Line 8**.

- 2 In the **Settings** window for **Arrow Line**, locate the **Expression** section.
- 3 In the **X-component** text field, type `mmtp.nTX_1_fft8`.
- 4 In the **Y-component** text field, type `mmtp.nTY_1_fft8`.

Transformation 1

- 1 In the **Model Builder** window, expand the **Arrow Line 8** node, then click **Transformation 1**.
- 2 In the **Settings** window for **Transformation**, locate the **Transformation** section.
- 3 In the **X** text field, type 180.

Arrow Line 8, Line 8

- 1 In the **Model Builder** window, under **Results > Magnetic force harmonics**, Ctrl-click to select **Line 8** and **Arrow Line 8**.
- 2 Right-click and choose **Duplicate**.

Transformation 1

- 1 In the **Model Builder** window, expand the **Results > Magnetic force harmonics > Line 9** node, then click **Transformation 1**.
- 2 In the **Settings** window for **Transformation**, locate the **Transformation** section.
- 3 In the **X** text field, type 0.
- 4 In the **Y** text field, type -120.

Arrow Line 9

- 1 In the **Model Builder** window, under **Results > Magnetic force harmonics** click **Arrow Line 9**.
- 2 In the **Settings** window for **Arrow Line**, locate the **Expression** section.
- 3 In the **X-component** text field, type `mmtp.nTX_1_fft9`.
- 4 In the **Y-component** text field, type `mmtp.nTY_1_fft9`.

Transformation 1

- 1 In the **Model Builder** window, expand the **Arrow Line 9** node, then click **Transformation 1**.
- 2 In the **Settings** window for **Transformation**, locate the **Transformation** section.
- 3 In the **X** text field, type 0.
- 4 In the **Y** text field, type -120.

Arrow Line 9, Line 9

- 1 In the **Model Builder** window, under **Results > Magnetic force harmonics**, Ctrl-click to select **Line 9** and **Arrow Line 9**.
- 2 Right-click and choose **Duplicate**.

Transformation I

- 1 In the **Model Builder** window, expand the **Results > Magnetic force harmonics > Line 10** node, then click **Transformation I**.
- 2 In the **Settings** window for **Transformation**, locate the **Transformation** section.
- 3 In the **X** text field, type 60.

Arrow Line 10

- 1 In the **Model Builder** window, under **Results > Magnetic force harmonics** click **Arrow Line 10**.
- 2 In the **Settings** window for **Arrow Line**, locate the **Expression** section.
- 3 In the **X-component** text field, type `mmt.p.nTX_1_fft10`.
- 4 In the **Y-component** text field, type `mmt.p.nTY_1_fft10`.

Transformation I

- 1 In the **Model Builder** window, expand the **Arrow Line 10** node, then click **Transformation I**.
- 2 In the **Settings** window for **Transformation**, locate the **Transformation** section.
- 3 In the **X** text field, type 60.
- 4 Click the  **Zoom Extents** button in the **Graphics** toolbar.

Arrow Line 10, Line 10

- 1 In the **Model Builder** window, under **Results > Magnetic force harmonics**, Ctrl-click to select **Line 10** and **Arrow Line 10**.
- 2 Right-click and choose **Duplicate**.

Transformation I

- 1 In the **Model Builder** window, expand the **Results > Magnetic force harmonics > Line 11** node, then click **Transformation I**.
- 2 In the **Settings** window for **Transformation**, locate the **Transformation** section.
- 3 In the **X** text field, type 120.

Arrow Line 11

- 1 In the **Model Builder** window, under **Results > Magnetic force harmonics** click **Arrow Line 11**.
- 2 In the **Settings** window for **Arrow Line**, locate the **Expression** section.
- 3 In the **X-component** text field, type `mmt.p.nTX_1_fft11`.
- 4 In the **Y-component** text field, type `mmt.p.nTY_1_fft11`.

Transformation 1

- 1 In the **Model Builder** window, expand the **Arrow Line 11** node, then click **Transformation 1**.
- 2 In the **Settings** window for **Transformation**, locate the **Transformation** section.
- 3 In the **X** text field, type 120.

Arrow Line 11, Line 11

- 1 In the **Model Builder** window, under **Results > Magnetic force harmonics**, Ctrl-click to select **Line 11** and **Arrow Line 11**.
- 2 Right-click and choose **Duplicate**.

Line 12

In the **Model Builder** window, expand the **Results > Magnetic force harmonics > Line 12** node.

Transformation 1

- 1 In the **Model Builder** window, expand the **Results > Magnetic force harmonics > Arrow Line 12** node, then click **Results > Magnetic force harmonics > Line 12 > Transformation 1**.
- 2 In the **Settings** window for **Transformation**, locate the **Transformation** section.
- 3 In the **X** text field, type 180.

Arrow Line 12

- 1 In the **Model Builder** window, under **Results > Magnetic force harmonics** click **Arrow Line 12**.
- 2 In the **Settings** window for **Arrow Line**, locate the **Expression** section.
- 3 In the **X-component** text field, type `mmtp.nTX_1_fft12`.
- 4 In the **Y-component** text field, type `mmtp.nTY_1_fft12`.

Transformation 1

- 1 In the **Model Builder** window, click **Transformation 1**.
- 2 In the **Settings** window for **Transformation**, locate the **Transformation** section.
- 3 In the **X** text field, type 180.

Arrow Line 1

- 1 In the **Model Builder** window, under **Results > Magnetic force harmonics** click **Arrow Line 1**.
- 2 In the **Settings** window for **Arrow Line**, locate the **Coloring and Style** section.
- 3 Select the **Scale factor** checkbox. In the associated text field, type `1e-4`.

4 In the **Magnetic force harmonics** toolbar, click  **Plot**.

RESULTS

Magnetic force harmonics

In the **Model Builder** window, collapse the **Results > Magnetic force harmonics** node.

Campbell diagram

1 In the **Model Builder** window, click **Campbell diagram**.

2 In the **Campbell diagram** toolbar, click  **Plot**.