



Model created in COMSOL Multiphysics 6.4

Neuron over Microelectrode Array

Introduction

Microelectrode arrays (MEAs) enable long and stable extracellular recordings of neuronal activity and are thus widely used in neuroscience applications. This tutorial model shows how to describe the interaction of a mammalian neuron with an MEA, with a focus on the transduction of the neuronal ionic activity into an electrically recorded signal.

Neurons are excitable cells capable of generating and propagating electric signals called *action potentials*. This phenomenon is modeled here using a multicompartment Hodgkin–Huxley (HH)-like computational model for a membrane with parameters related to a specific type of mammalian neuron (Rat RGC Type I), as reported in [Ref. 1](#). The HH model relates the net membrane potential change over time (V_{memb}) to the effective ionic exchange across the membrane through sodium (I_{Na}), potassium (I_{K}), and leakage (I_{l}) current densities that depend on the evolution of three gating variables, n , m , and h :

$$C_m \frac{dV_{\text{memb}}(t)}{dt} = I_{\text{Na}}(V_{\text{memb}}(t), m, h) + I_{\text{K}}(V_{\text{memb}}(t), n) + I_{\text{l}}(V_{\text{memb}}(t)) + I_{\text{stim}} \quad (1)$$
$$\frac{dq}{dt} = \alpha_q(V_{\text{memb}}(t)) \cdot (1 - q) - \beta_q(V_{\text{memb}}(t)) \cdot q \quad \text{for } q = \{m, n, h\}$$

Here

- C_m is the membrane capacitance per unit area
- I_{stim} is an external stimulation current density required to unbalance the steady-state solution until the threshold for action potential generation is reached
- α_q and β_q are the gating rate constants, whose values are taken from [Ref. 1](#)

Each ion current density also depends on the corresponding ion current conductance and equilibrium potential, but these are not included in [Equation 1](#) to improve readability. The gating rate constants, the ion current conductances, and the equilibrium potentials are all taken from [Ref. 1](#) for $T = 35^\circ\text{C}$.

The neuron intracellular solution and the extracellular solution are reservoirs of diluted ions. Considering both as neutral, monovalent electrolyte solutions, they can be treated as ohmic conductors with electric conductivity proportional to the ion concentration, valence and mobility, and permittivity of water. The conductivity of the neuron intracellular solution is taken from [Ref. 1](#) for $T = 35^\circ\text{C}$. These assumptions allow for simplifying the description of the ionic currents in [Equation 1](#) as equivalent electric currents carrying the same net charge over time across the membrane.

Model Definition

Figure 1 shows the 3D geometry of the system, which includes a neuron over a portion of a microelectrode array (5-by-28 electrodes). The external box constitutes the extracellular solution domain. Notice that the neuron geometry has been constructed considering realistic numbers for the main relevant compartments: dendrites, soma, hillock, axon initial segment (AIS), and axon.

Figure 2 shows the computational mesh. For better visualization, Figure 3 shows a zoomed view of the mesh on the MEA and neuron. The mesh is refined along the longitudinal edges of the neuron facing the MEA and coarse elsewhere to save mesh size.

The implementation requires the use of two Electric Currents interfaces and one Boundary ODEs and DAEs interface. The Electric Currents interfaces model the conductive media solutions inside and outside the neuron membrane. They are also required to set the reference electrode (the upper face of the box) as well as the microelectrode array's terminals. The latter interface allows to incorporate on the cell membrane the Hodgkin–Huxley-like model for the generation of action potentials.

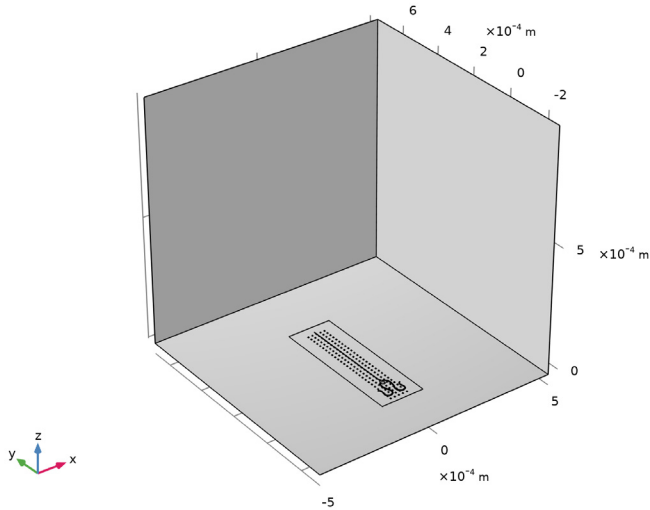

Figure 1: 3D geometry of the neuron over a microelectrode array (MEA) and the surrounding extracellular domain.

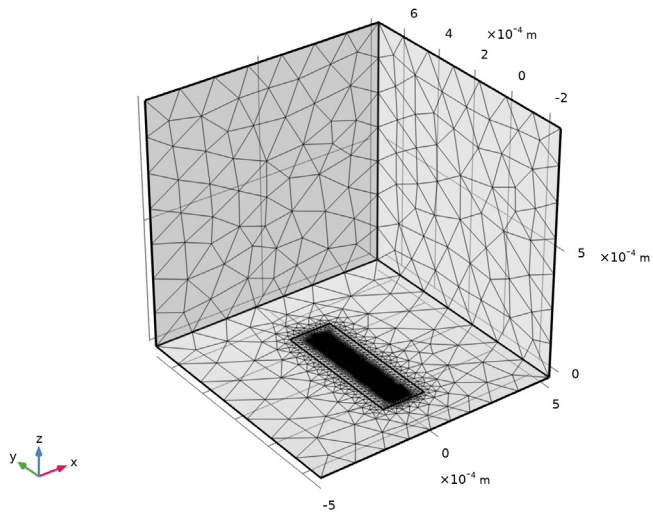

Figure 2: Computational mesh.

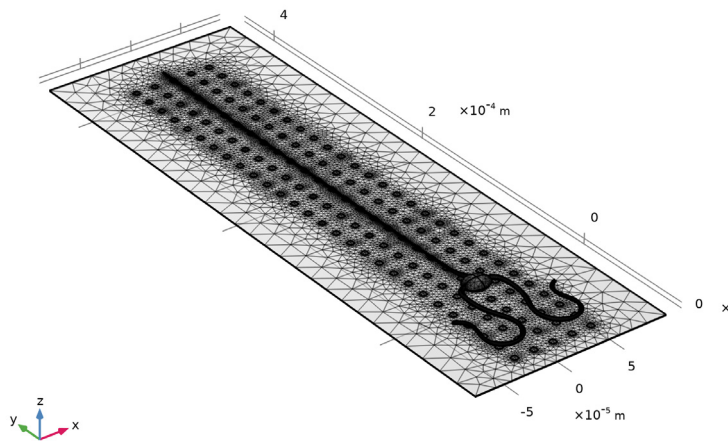

Figure 3: Zoomed view of the computational mesh on the MEA and the neuron.

Results and Discussion

This tutorial performs a time dependent study in which the transient response to an action potential is recorded from the extracellular MEA.

Figure 4 shows the membrane potentials sampled at point probes located on main neuron membrane compartments. The Axon Initial Segment (AIS) compartment is the richest in Sodium ion channels and is the first to show an action potential. After that, Hillock and Soma, Dendrite, and finally Axon show sequentially the action potential.

Figure 5 illustrates a snapshot of the extracellular electric potential during the action potential propagation along the neuron. The red and blue nearby spots on the MEA suggests that the action potential has reached the two third of the axon at that time step.

Figure 6 depicts the extracellular electric signals recorded by a fraction of microelectrodes located under main neuron compartments. The recorded traces allow us to assess the generation and propagation of the action potential from the outside of the neuron. This finding is consistent with the plot in Figure 4.

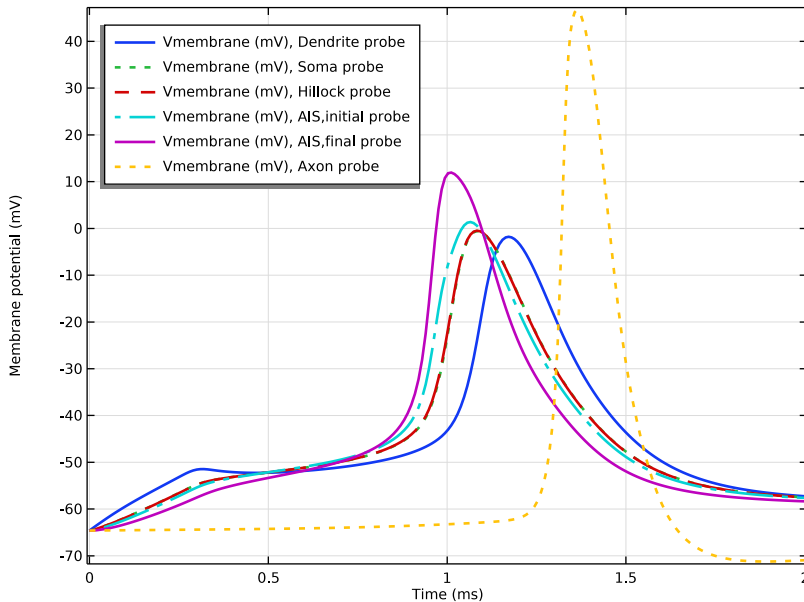

Figure 4: Membrane potential probed at different neuron compartments.

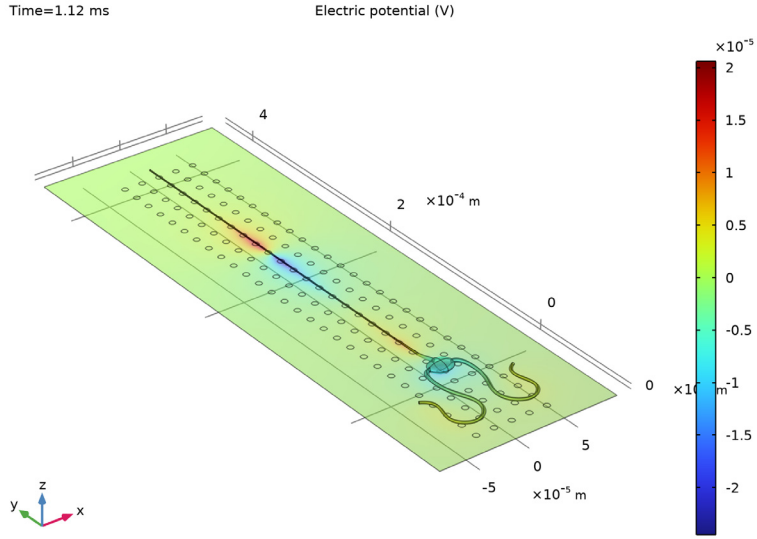

Figure 5: Extracellular potential surface plot during an action potential propagation.

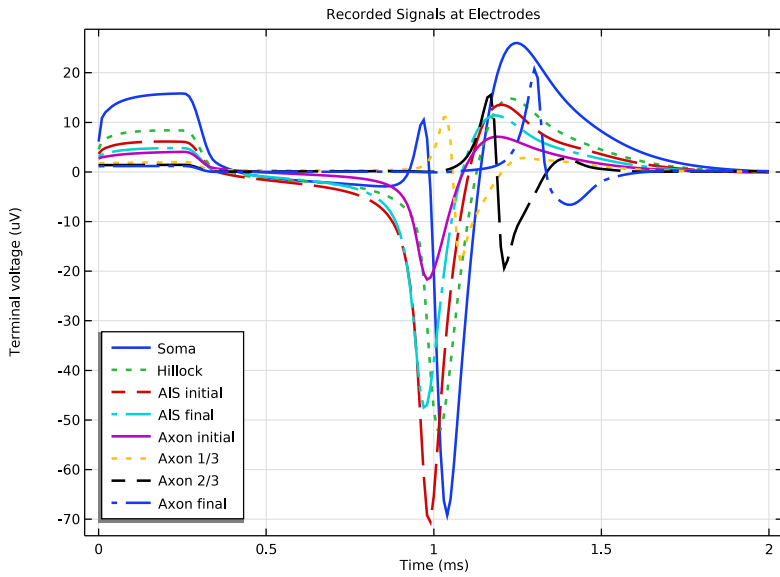

Figure 6: Electric signals recorded at microelectrodes under main neuron compartments.

Reference

1. J.F. Fohlmeister, D. Ethan, and E.A. Newman, “Mechanisms and Distribution of Ion Channels in Retinal Ganglion Cells: Using Temperature as an Independent Variable,” *J. Neurophysiology*, vol. 103, no. 3, pp. 1357–1374, 2010.

The parameter values for the Hodgkin–Huxley-type model used in this tutorial were taken from [Ref. 1](#).

Application Library path: ACDC_Module/Devices,_Resistive/
neuron_over_microelectrode_array



Modeling Instructions

From the **File** menu, choose **New**.

NEW

In the **New** window, click  **Model Wizard**.

MODEL WIZARD

- 1 In the **Model Wizard** window, click  **3D**.
- 2 In the **Select Physics** tree, select **AC/DC** > **Electric Fields and Currents** > **Electric Currents (ec)**.
- 3 Click **Add**.
- 4 In the **Select Physics** tree, select **AC/DC** > **Electric Fields and Currents** > **Electric Currents (ec)**.
- 5 Click **Add**.
- 6 In the **Select Physics** tree, select **Mathematics** > **ODE and DAE Interfaces** > **Boundary ODEs and DAEs (bode)**.
- 7 Click **Add**.
- 8 Click  **Study**.
- 9 In the **Select Study** tree, select **General Studies** > **Time Dependent**.
- 10 Click  **Done**.

GEOMETRY I

First, define the geometric and physical parameters of the model.

GLOBAL DEFINITIONS

Geometric Parameters

- 1 In the **Model Builder** window, under **Global Definitions** click **Parameters I**.
- 2 In the **Settings** window for **Parameters**, type Geometric Parameters in the **Label** text field.
- 3 Locate the **Parameters** section. In the table, enter the following settings:

Name	Expression	Value	Description
r_soma	10[um]	1E-5 m	Radius of the soma
r_hillock	1.8[um]	1.8E-6 m	Radius of the hillock
r_AIS	1[um]	1E-6 m	Radius of the AIS
r_axon	0.5[um]	5E-7 m	Radius of the axon
r_dendrite_ini	1.8[um]	1.8E-6 m	Radius of the dendrite, initial part
r_dendrite_fin	1.2[um]	1.2E-6 m	Radius of the edendrite, final part
l_hillock	20[um]	2E-5 m	Length of the hillock
l_AIS	30[um]	3E-5 m	Length of the AIS
l_axon	350[um]	3.5E-4 m	Length of the axon
l_box	1[mm]	0.001 m	Length of edge of the extracellular solution box
t_cleft	70[nm]	7E-8 m	Thickness of the cleft between neuron and electrodes

Physical Parameters

- 1 In the **Home** toolbar, click **Pi Parameters** and choose **Add > Parameters**.
- 2 In the **Settings** window for **Parameters**, type Physical Parameters in the **Label** text field.

3 Locate the **Parameters** section. In the table, enter the following settings:

Name	Expression	Value	Description
epsr_water	80	80	Relative permittivity of water
sigma_neuron	$1 / (143.2[\text{ohm} \cdot \text{cm}])$	0.69832 S/m	Electrical conductivity of the neuron
sigma_solution	$1 / (100[\text{ohm} \cdot \text{cm}])$	1 S/m	Electrical conductivity of the extracellular solution

Electrode Parameters

- 1 In the **Home** toolbar, click **Pi Parameters** and choose **Add > Parameters**.
- 2 In the **Settings** window for **Parameters**, type Electrode Parameters in the **Label** text field.
- 3 Locate the **Parameters** section. In the table, enter the following settings:

Name	Expression	Value	Description
r_ele	3[um]	3E-6 m	Electrode radius
pitch_ele	18[um]	1.8E-5 m	Pitch between electrodes
row_ele	5	5	Number of rows in the array
col_ele	28	28	Number of columns in the array

Neuron Parameters

- 1 In the **Home** toolbar, click **Pi Parameters** and choose **Add > Parameters**.
- 2 In the **Settings** window for **Parameters**, type Neuron Parameters in the **Label** text field.
- 3 Locate the **Parameters** section. In the table, enter the following settings:

Name	Expression	Value	Description
VLO	-64.58[mV]	-0.06458 V	Reversal potential of leakage channel
VK0	-101.34[mV]	-0.10134 V	Reversal potential of K ⁺ channels
VNa0	60.60[mV]	0.0606 V	Reversal potential of Na ⁺ channels

Name	Expression	Value	Description
Cm	1[uF/cm ²]	0.01 F/m ²	Membrane capacitance per unit area
gL_bar	0.3[mS/cm ²]	3 S/m ²	Conductivity of leakage channels
gNa_bar_D	0.4*79.5[mS/cm ²]	318 S/m ²	Conductivity of Na ⁺ channels @ Dendrite
gNa_bar_S	72[mS/cm ²]	720 S/m ²	Conductivity of Na ⁺ channels @ Soma
gNa_bar_H	141[mS/cm ²]	1410 S/m ²	Conductivity of Na ⁺ channels @ Hillock
gNa_bar_AIS	231[mS/cm ²]	2310 S/m ²	Conductivity of Na ⁺ channels @ Axon Initial Segment (AIS)
gNa_bar_A	124[mS/cm ²]	1240 S/m ²	Conductivity of Na ⁺ channels @ Axon
gK_bar_D	23.4[mS/cm ²]	234 S/m ²	Conductivity of K ⁺ channels @ Dendrite
gK_bar_S	50.4[mS/cm ²]	504 S/m ²	Conductivity of K ⁺ channels @ Soma
gK_bar_H	67.8[mS/cm ²]	678 S/m ²	Conductivity of K ⁺ channels @ Hillock
gK_bar_AIS	74.6[mS/cm ²]	746 S/m ²	Conductivity of K ⁺ channels @ Axon Initial Segment (AIS)
gK_bar_A	50[mS/cm ²]	500 S/m ²	Conductivity of K ⁺ channels @ Axon
Vr	-64.6[mV]	-0.0646 V	Rest potential of the membrane
Istim	55[uA/cm ²]	0.55 A/m ²	Dendritic stimulation current density

Build the geometry with the following instructions.

GEOMETRY I

Soma

1 In the **Geometry** toolbar, click  **More Primitives** and choose **Ellipsoid**.

2 In the **Settings** window for **Ellipsoid**, type Soma in the **Label** text field.

- 3 Locate the **Size and Shape** section. In the **a-semiaxis** text field, type $r_soma*1.2$.
- 4 In the **b-semiaxis** text field, type r_soma .
- 5 In the **c-semiaxis** text field, type $r_soma*0.5$.
- 6 Locate the **Selections of Resulting Entities** section. Select the **Resulting objects selection** checkbox.

Work Plane 1 (wp1)

- 1 In the **Geometry** toolbar, click  **Work Plane**.
- 2 In the **Settings** window for **Work Plane**, locate the **Plane Definition** section.
- 3 From the **Plane** list, choose **xz-plane**.
- 4 In the **y-coordinate** text field, type $r_soma - r_soma/10$.

Work Plane 1 (wp1) > Plane Geometry

In the **Model Builder** window, click **Plane Geometry**.

Work Plane 1 (wp1) > Circle 1 (c1)

- 1 In the **Work Plane** toolbar, click  **Circle**.
- 2 In the **Settings** window for **Circle**, locate the **Size and Shape** section.
- 3 In the **Radius** text field, type $r_hillock$.
- 4 Locate the **Selections of Resulting Entities** section. Select the **Resulting objects selection** checkbox.

Work Plane 2 (wp2)

- 1 In the **Model Builder** window, right-click **Geometry 1** and choose **Work Plane**.
- 2 In the **Settings** window for **Work Plane**, locate the **Plane Definition** section.
- 3 From the **Plane** list, choose **yz-plane**.

Work Plane 2 (wp2) > Plane Geometry

In the **Model Builder** window, click **Plane Geometry**.

Work Plane 2 (wp2) > Polygon 1 (pol1)

- 1 In the **Work Plane** toolbar, click  **Polygon**.
- 2 In the **Settings** window for **Polygon**, locate the **Object Type** section.
- 3 From the **Type** list, choose **Open curve**.

4 Locate the **Coordinates** section. In the table, enter the following settings:

xw (m)	yw (m)
$r_soma*0.9$	0
r_soma	0
$r_soma+l_hillock/2$	$-r_soma*0.25$
$r_soma+l_hillock*0.9$	$-r_soma*0.5+r_AIS*1.1$
$r_soma+l_hillock$	$-r_soma*0.5+r_AIS$
$r_soma+l_hillock+l_AIS$	$-r_soma*0.5+r_axon$

5 Locate the **Selections of Resulting Entities** section. Select the **Resulting objects selection** checkbox.





6 From the **Show in 3D** list, choose **Boundary selection**.

Hillock

- 1 In the **Model Builder** window, right-click **Geometry 1** and choose **Sweep**.
- 2 In the **Settings** window for **Sweep**, type Hillock in the **Label** text field.
- 3 Locate the **Cross Section** section. Clear the **Create cross-sectional faces** checkbox.
- 4 Locate the **Spine Curve** section. From the **Parameterization** list, choose **Normalized arc length**.
- 5 Locate the **Cross Section** section. From the **Entities to sweep** list, choose **Circle 1 (Work Plane 1)**.
- 6 Locate the **Spine Curve** section. Click to select the **Activate Selection** toggle button for **Edges to follow**.
- 7 Click the  **Clear Selection** button for **Edges to follow**.
- 8 On the object **wp2**, select Edges 1–4 only.
- 9 Locate the **Input Object Handling** section. Select the **Include all inputs in Form Union/Assembly** checkbox.
- 10 Locate the **Motion of Cross Section** section. Find the **Additional twisting and scaling** subsection. In the **Scale factor** text field, type $(1 - (r_hillock - r_AIS) / r_hillock * s)$.
- 11 Locate the **Selections of Resulting Entities** section. Select the **Resulting objects selection** checkbox.

AIS

- 1 Right-click **Hillock** and choose **Duplicate**.
- 2 In the **Settings** window for **Sweep**, type AIS in the **Label** text field.

- 3 Locate the **Cross Section** section. Click to select the  **Activate Selection** toggle button for **Entities to sweep**.
- 4 In the tree, select **wp1**.
- 5 Click the  **Clear Selection** button for **Entities to sweep**.
- 6 On the object **sw1**, select Boundary 4 only.
- 7 Locate the **Spine Curve** section. Click to select the  **Activate Selection** toggle button for **Edges to follow**.
- 8 In the tree, select **wp2**.
- 9 Click the  **Clear Selection** button for **Edges to follow**.
- 10 On the object **wp2**, select Edge 5 only.
- 11 Locate the **Motion of Cross Section** section. Find the **Additional twisting and scaling** subsection. In the **Scale factor** text field, type $(1 - (r_AIS - r_axon) / r_AIS * s)$.
- 12 Click  **Build Selected**.

Work Plane 3 (wp3)

- 1 In the **Geometry** toolbar, click  **Work Plane**.
- 2 In the **Settings** window for **Work Plane**, locate the **Plane Definition** section.
- 3 From the **Offset type** list, choose **Through vertex**.
- 4 On the object **wp2**, select Point 6 only.

Work Plane 3 (wp3) > Plane Geometry

In the **Model Builder** window, click **Plane Geometry**.





Work Plane 3 (wp3) > Polygon 1 (pol1)

- 1 In the **Work Plane** toolbar, click  **Polygon**.
- 2 In the **Settings** window for **Polygon**, locate the **Object Type** section.
- 3 From the **Type** list, choose **Open curve**.
- 4 Locate the **Coordinates** section. In the table, enter the following settings:

xw (m)	yw (m)
0	r_soma+1_hillock+1_AIS
0	r_soma+1_hillock+1_AIS+1_axon

- 5 Locate the **Selections of Resulting Entities** section. Select the **Resulting objects selection** checkbox.
- 6 From the **Show in 3D** list, choose **Boundary selection**.

Axon

- 1 In the **Model Builder** window, under **Component 1 (comp1) > Geometry 1** right-click **AIS (swe2)** and choose **Duplicate**.
- 2 In the **Settings** window for **Sweep**, type **Axon** in the **Label** text field.
- 3 Locate the **Cross Section** section. Click to select the  **Activate Selection** toggle button for **Entities to sweep**.
- 4 In the tree, select **swe1**.
- 5 Click the  **Clear Selection** button for **Entities to sweep**.
- 6 On the object **swe2**, select Boundary 4 only.
- 7 Locate the **Spine Curve** section. Click to select the  **Activate Selection** toggle button for **Edges to follow**.
- 8 In the tree, select **wp2**.
- 9 Click the  **Clear Selection** button for **Edges to follow**.
- 10 On the object **wp3**, select Edge 1 only.
- 11 Locate the **Motion of Cross Section** section. Find the **Additional twisting and scaling** subsection. In the **Scale factor** text field, type 1.
- 12 Click  **Build Selected**.

Work Plane 4 (wp4)

- 1 In the **Model Builder** window, right-click **Geometry 1** and choose **Work Plane**.
- 2 In the **Settings** window for **Work Plane**, locate the **Plane Definition** section.
- 3 From the **Plane** list, choose **yz-plane**.
- 4 In the **x-coordinate** text field, type $r_soma * 1.1$.

Work Plane 4 (wp4) > Plane Geometry

In the **Model Builder** window, click **Plane Geometry**.

Work Plane 4 (wp4) > Circle 1 (c1)

- 1 In the **Work Plane** toolbar, click  **Circle**.
- 2 In the **Settings** window for **Circle**, locate the **Size and Shape** section.
- 3 In the **Radius** text field, type $r_dendrite_ini$.
- 4 Locate the **Selections of Resulting Entities** section. Select the **Resulting objects selection** checkbox.

Work Plane 5 (wp5)

In the **Model Builder** window, right-click **Geometry 1** and choose **Work Plane**.



Work Plane 5 (wp5) > Interpolation Curve 1 (ic1)

- 1 In the **Work Plane** toolbar, click  **More Primitives** and choose **Interpolation Curve**.
- 2 In the **Settings** window for **Interpolation Curve**, locate the **Interpolation Points** section.
- 3 In the table, enter the following settings:

xw (m)	yw (m)
1.1E-5	0
1.2472435628296807E-5	-2.0E-7
2.0E-5	-2.0E-5
1.6E-5	-4.0E-5
1.0E-5	-6.0E-5
1.2472435628296807E-5	-7.0E-5
3.0E-5	-8.0E-5
4.2395896444795656E-5	-7.0E-5
4.0E-5	-5.0E-5
4.8E-5	-3.3E-5

- 4 Locate the **Selections of Resulting Entities** section. Select the **Resulting objects selection** checkbox.
- 5 From the **Show in 3D** list, choose **Boundary selection**.

Dendrite

- 1 In the **Model Builder** window, under **Component 1 (comp1) > Geometry 1** right-click **Axon (swe3)** and choose **Duplicate**.
- 2 In the **Settings** window for **Sweep**, type **Dendrite** in the **Label** text field.
- 3 Locate the **Input Object Handling** section. Clear the **Keep input objects** checkbox.
- 4 Locate the **Cross Section** section. Click to select the **Activate Selection** toggle button for **Entities to sweep**.
- 5 In the tree, select **swe2**.
- 6 Click the  **Clear Selection** button for **Entities to sweep**.
- 7 From the **Entities to sweep** list, choose **Circle 1 (Work Plane 4)**.
- 8 Locate the **Spine Curve** section. Click to select the **Activate Selection** toggle button for **Edges to follow**.
- 9 In the tree, select **wp3**.
- 10 Click the  **Clear Selection** button for **Edges to follow**.
- 11 On the object **wp5**, select Edge 1 only.

12 Locate the **Motion of Cross Section** section. Find the **Additional twisting and scaling** subsection. In the **Scale factor** text field, type $(1 - (r_dendrite_ini - r_dendrite_fin) / r_dendrite_ini * s)$.

13 Click  **Build Selected**.

Mirror 1 (mir1)

1 In the **Model Builder** window, right-click **Geometry 1** and choose **Transforms > Mirror**.

2 In the **Settings** window for **Mirror**, locate the **Input** section.

3 From the **Input objects** list, choose **Dendrite**.

4 Select the **Keep input objects** checkbox.

5 Locate the **Normal Vector to Plane of Reflection** section. In the **x** text field, type -1.

6 In the **z** text field, type 0.

Block 1 (blk1)

1 In the **Geometry** toolbar, click  **Block**.

2 In the **Settings** window for **Block**, locate the **Size and Shape** section.

3 In the **Width** text field, type 1_box.

4 In the **Depth** text field, type 1_box.

5 In the **Height** text field, type 1_box.

6 Locate the **Position** section. In the **x** text field, type $-1_box/2$.

7 In the **y** text field, type $-1_box/2 + 1_axon/2 + 2 * r_soma$.

8 In the **z** text field, type $-t_cleft - r_soma * 0.5 - r_axon$.

9 Click  **Build Selected**.

Work Plane 6 (wp6)

1 In the **Geometry** toolbar, click  **Work Plane**.

2 In the **Settings** window for **Work Plane**, locate the **Plane Definition** section.

3 From the **Offset type** list, choose **Through vertex**.

4 Click the  **Zoom Extents** button in the **Graphics** toolbar.

5 On the object **blk1**, select Point 1 only.

6 Locate the **Selections of Resulting Entities** section. Find the **Selections from plane geometry** subsection. Select the **Show in physics** checkbox.

Work Plane 6 (wp6) > Plane Geometry

In the **Model Builder** window, click **Plane Geometry**.

Work Plane 6 (wp6) > Circle 1 (c1)

- 1 In the **Work Plane** toolbar, click  **Circle**.
- 2 In the **Settings** window for **Circle**, locate the **Size and Shape** section.
- 3 In the **Radius** text field, type `r_ele`.
- 4 Locate the **Position** section. In the **xw** text field, type `-2*pitch_ele`.
- 5 In the **yw** text field, type `-5*pitch_ele`.



Work Plane 6 (wp6) > Array 1 (arr1)

- 1 In the **Work Plane** toolbar, click  **Transforms** and choose **Array**.
- 2 Select the object **c1** only.
- 3 In the **Settings** window for **Array**, locate the **Size** section.
- 4 In the **xw size** text field, type `row_ele`.
- 5 In the **yw size** text field, type `col_ele`.
- 6 Locate the **Displacement** section. In the **xw** text field, type `pitch_ele`.
- 7 In the **yw** text field, type `pitch_ele`.
- 8 Locate the **Selections of Resulting Entities** section. Select the **Resulting objects selection** checkbox.

Work Plane 6 (wp6) > Box Selection 1 (boxsel1)

- 1 In the **Work Plane** toolbar, click  **Selections** and choose **Box Selection**.
- 2 In the **Settings** window for **Box Selection**, locate the **Box Limits** section.
- 3 In the **xw minimum** text field, type `-pitch_ele/1.5`.
- 4 In the **xw maximum** text field, type `pitch_ele/1.5`.
- 5 In the **yw minimum** text field, type `-r_soma`.
- 6 In the **yw maximum** text field, type `l_box/2`.

Work Plane 6 (wp6) > Rectangle 1 (r1)

- 1 In the **Work Plane** toolbar, click  **Rectangle**.
- 2 In the **Settings** window for **Rectangle**, locate the **Size and Shape** section.
- 3 In the **Width** text field, type `row_ele*pitch_ele*2`.
- 4 In the **Height** text field, type `col_ele*pitch_ele*1.1`.
- 5 Locate the **Position** section. In the **yw** text field, type `l_axon/2-r_soma`.
- 6 From the **Base** list, choose **Center**.
- 7 Click  **Build Selected**.



Difference 1 (dif1)

- 1 In the **Model Builder** window, right-click **Geometry 1** and choose **Booleans and Partitions** > **Difference**.
- 2 Select the objects **mir1**, **sw1**, and **swe4** only.
- 3 In the **Settings** window for **Difference**, locate the **Difference** section.
- 4 Click to select the  **Activate Selection** toggle button for **Objects to subtract**.
- 5 From the **Objects to subtract** list, choose **Soma**.
- 6 Select the **Keep objects to subtract** checkbox.

Delete Entities 1 (del1)

- 1 Right-click **Geometry 1** and choose **Delete Entities**.
- 2 On the object **wp1**, select Boundary 1 only.

Delete Entities 2 (del2)



- 1 Right-click **Geometry 1** and choose **Delete Entities**.
- 2 In the **Settings** window for **Delete Entities**, locate the **Entities or Objects to Delete** section.
- 3 From the **Geometric entity level** list, choose **Edge**.
- 4 On the object **wp2**, select Edges 1–5 only.
- 5 On the object **wp3**, select Edge 1 only.
- 6 Click  **Build Selected**.
- 7 In the **Geometry** toolbar, click  **Build All**.
- 8 Click  **Cleanup Wizard**.

CLEANUP WIZARD

- 1 Go to the **Cleanup Wizard** window.
- 2 Click the **Manual** button.
- 3 In the **Detail size** text field, type 1E-8.
- 4 Click the **Apply** button in the window toolbar.
- 5 Click the **Apply** button in the window toolbar.
- 6 Click the **Done** button in the window toolbar.



GEOMETRY 1

- 1 In the **Model Builder** window, under **Component 1 (comp1)** click **Geometry 1**.

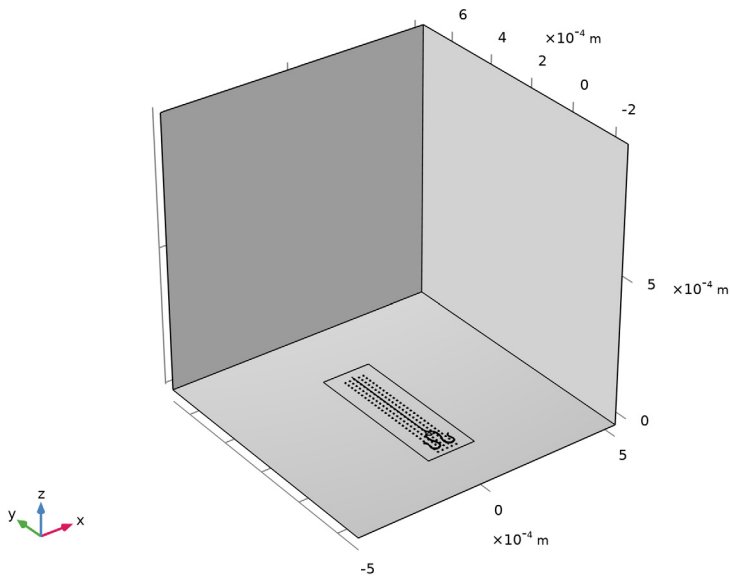
- 2 In the **Graphics** window toolbar, click ▼ next to  **Select Edges**, then choose **Select Boundaries**.
- 3 Click the  **Click and Hide** button in the **Graphics** toolbar.
- 4 On the object **aigv2**, select Boundary 1 only.
- 5 On the object **aigv2**, select Boundary 4 only.
- 6 On the object **aigv2**, select Boundary 2 only.
- 7 Click the  **Zoom Extents** button in the **Graphics** toolbar.



Neuron

- 1 In the **Geometry** toolbar, click  **Selections** and choose **Union Selection**.
- 2 In the **Settings** window for **Union Selection**, type Neuron in the **Label** text field.
- 3 Locate the **Input Entities** section. Click  **Add**.
- 4 In the **Add** dialog, in the **Selections to add** list, choose **Soma, Hillock, AIS, Axon, and Dendrite**.
- 5 Click **OK**.

All Neuron Boundaries

- 1 In the **Geometry** toolbar, click  **Selections** and choose **Adjacent Selection**.

- 2 In the **Settings** window for **Adjacent Selection**, type All Neuron Boundaries in the **Label** text field.
- 3 Locate the **Input Entities** section. Click **+ Add**.
- 4 In the **Add** dialog, select **Neuron** in the **Input selections** list.
- 5 Click **OK**.

Neuron Caps

- 1 In the **Geometry** toolbar, click  **Selections** and choose **Explicit Selection**.
- 2 In the **Settings** window for **Explicit Selection**, locate the **Entities to Select** section.
- 3 From the **Geometric entity level** list, choose **Boundary**.
- 4 On the object **aigv2**, select Boundaries 7, 113, and 189 only.
- 5 In the **Label** text field, type Neuron Caps.

Neuron Boundary

- 1 In the **Geometry** toolbar, click  **Selections** and choose **Difference Selection**.
- 2 In the **Settings** window for **Difference Selection**, type Neuron Boundary in the **Label** text field.
- 3 Locate the **Geometric Entity Level** section. From the **Level** list, choose **Boundary**.
- 4 Locate the **Input Entities** section. Click the **+ Add** button for **Selections to add**.
- 5 In the **Add** dialog, select **All Neuron Boundaries** in the **Selections to add** list.
- 6 Click **OK**.
- 7 In the **Settings** window for **Difference Selection**, locate the **Input Entities** section.
- 8 Click the **+ Add** button for **Selections to subtract**.
- 9 In the **Add** dialog, select **Neuron Caps** in the **Selections to subtract** list.
- 10 Click **OK**.

Dendrite Boundary

- 1 In the **Geometry** toolbar, click  **Selections** and choose **Adjacent Selection**.
- 2 In the **Settings** window for **Adjacent Selection**, type Dendrite Boundary in the **Label** text field.
- 3 Locate the **Input Entities** section. Click **+ Add**.
- 4 In the **Add** dialog, select **Dendrite** in the **Input selections** list.
- 5 Click **OK**.

Assign the neuron parameters to the corresponding membrane regions.

DEFINITIONS

Variables Dendrites

- 1 In the **Model Builder** window, expand the **Component 1 (comp1) > Definitions** node.
- 2 Right-click **Definitions** and choose **Variables**.
- 3 In the **Settings** window for **Variables**, locate the **Geometric Entity Selection** section.
- 4 From the **Geometric entity level** list, choose **Domain**.
- 5 From the **Selection** list, choose **Dendrite**.
- 6 In the **Label** text field, type **Variables Dendrites**.
- 7 Locate the **Variables** section. In the table, enter the following settings:

Name	Expression	Unit	Description
gNa_bar_x	gNa_bar_D	S/m ²	Conductivity of Na ⁺ channels @ Dendrite
gK_bar_x	gK_bar_D	S/m ²	Conductivity of K ⁺ channels @ Dendrite

Variables Soma

- 1 Right-click **Definitions** and choose **Variables**.
- 2 In the **Settings** window for **Variables**, locate the **Geometric Entity Selection** section.
- 3 From the **Geometric entity level** list, choose **Domain**.
- 4 From the **Selection** list, choose **Soma**.
- 5 In the **Label** text field, type **Variables Soma**.
- 6 Locate the **Variables** section. In the table, enter the following settings:

Name	Expression	Unit	Description
gNa_bar_x	gNa_bar_S	S/m ²	Conductivity of Na ⁺ channels @ Soma
gK_bar_x	gK_bar_S	S/m ²	Conductivity of K ⁺ channels @ Soma

Variables Hillock

- 1 Right-click **Definitions** and choose **Variables**.
- 2 In the **Settings** window for **Variables**, locate the **Geometric Entity Selection** section.
- 3 From the **Geometric entity level** list, choose **Domain**.
- 4 From the **Selection** list, choose **Hillock**.
- 5 In the **Label** text field, type **Variables Hillock**.

6 Locate the **Variables** section. In the table, enter the following settings:

Name	Expression	Unit	Description
gNa_bar_x	gNa_bar_H	S/m ²	Conductivity of Na ⁺ channels @ Hillock
gK_bar_x	gK_bar_H	S/m ²	Conductivity of K ⁺ channels @ Hillock

Variables AIS

- 1 Right-click **Definitions** and choose **Variables**.
- 2 In the **Settings** window for **Variables**, locate the **Geometric Entity Selection** section.
- 3 From the **Geometric entity level** list, choose **Domain**.
- 4 From the **Selection** list, choose **AIS**.
- 5 In the **Label** text field, type *Variables AIS*.
- 6 Locate the **Variables** section. In the table, enter the following settings:

Name	Expression	Unit	Description
gNa_bar_x	gNa_bar_AIS	S/m ²	Conductivity of Na ⁺ channels @ Axon Initial Segment (AIS)
gK_bar_x	gK_bar_AIS	S/m ²	Conductivity of K ⁺ channels @ Axon Initial Segment (AIS)

Variables Axon

- 1 Right-click **Definitions** and choose **Variables**.
- 2 In the **Settings** window for **Variables**, locate the **Geometric Entity Selection** section.
- 3 From the **Geometric entity level** list, choose **Domain**.
- 4 From the **Selection** list, choose **Axon**.
- 5 In the **Label** text field, type *Variables Axon*.
- 6 Locate the **Variables** section. In the table, enter the following settings:

Name	Expression	Unit	Description
gNa_bar_x	gNa_bar_A	S/m ²	Conductivity of Na ⁺ channels @ Axon
gK_bar_x	gK_bar_A	S/m ²	Conductivity of K ⁺ channels @ Axon

Variables Neuron

- 1 Right-click **Definitions** and choose **Variables**.
- 2 In the **Settings** window for **Variables**, locate the **Geometric Entity Selection** section.

- 3 From the **Geometric entity level** list, choose **Boundary**.
- 4 From the **Selection** list, choose **Neuron Boundary**.
- 5 In the **Label** text field, type Variables Neuron.
- 6 Locate the **Variables** section. In the table, enter the following settings:

Name	Expression	Unit	Description
Vmembrane	Vin-Vout		Membrane potential
INa	$g_{Na_bar_x} * m^3 * h^1 * (V_{membrane} - V_{Na0})$		Na+ current density
IK	$g_{K_bar_x} * n^4 * (V_{membrane} - V_{K0})$		K+ current density
IL	$g_{L_bar} * (V_{membrane} - V_{L0})$		Leakage current density
ICm	$Cm * d(V_{membrane}, t)$		Membrane capacitive current density

alpha_n

- 1 In the **Definitions** toolbar, click  **Analytic**.
- 2 In the **Settings** window for **Analytic**, type *alpha_n* in the **Label** text field.
- 3 In the **Function name** text field, type *alpha_n*.
- 4 Locate the **Definition** section. In the **Expression** text field, type $-0.09575 * (V_{membrane} / 1[mV] + 37) / (\exp(-0.1 * (V_{membrane} / 1[mV] + 37)) - 1)$.
- 5 In the **Arguments** text field, type Vmembrane.
- 6 Locate the **Units** section. In the table, enter the following settings:

Argument	Unit
Vmembrane	V

- 7 In the **Function** text field, type 1/ms.

beta_n

- 1 Right-click **alpha_n** and choose **Duplicate**.
- 2 In the **Settings** window for **Analytic**, type *beta_n* in the **Label** text field.
- 3 In the **Function name** text field, type *beta_n*.
- 4 Locate the **Definition** section. In the **Expression** text field, type $1.915 * \exp(-(V_{membrane} / 1[mV] + 47) / 80)$.

alpha_n (alpha_n), beta_n (beta_n)

- 1 In the **Model Builder** window, under **Component 1 (comp1) > Definitions**, Ctrl-click to select **alpha_n (alpha_n)** and **beta_n (beta_n)**.
- 2 Right-click and choose **Duplicate**.

alpha_m

- 1 In the **Settings** window for **Analytic**, type *alpha_m* in the **Label** text field.
- 2 In the **Function name** text field, type *alpha_m*.
- 3 Locate the **Definition** section. In the **Expression** text field, type $-2.725 * (V_{\text{membrane}} / 1[\text{mV}] + 35) / (\exp(-0.1 * (V_{\text{membrane}} / 1[\text{mV}] + 35)) - 1)$.

beta_m

- 1 In the **Model Builder** window, under **Component 1 (comp1) > Definitions** click **beta_n 1 (beta_n4)**.
- 2 In the **Settings** window for **Analytic**, type *beta_m* in the **Label** text field.
- 3 In the **Function name** text field, type *beta_m*.
- 4 Locate the **Definition** section. In the **Expression** text field, type $90.83 * \exp(-(V_{\text{membrane}} / 1[\text{mV}] + 60) / 20)$.

alpha_h

- 1 In the **Model Builder** window, under **Component 1 (comp1) > Definitions** right-click **alpha_n (alpha_n)** and choose **Duplicate**.
- 2 In the **Settings** window for **Analytic**, type *alpha_h* in the **Label** text field.
- 3 In the **Function name** text field, type *alpha_h*.
- 4 Locate the **Definition** section. In the **Expression** text field, type $1.817 * \exp(-(V_{\text{membrane}} / 1[\text{mV}] + 52) / 20)$.

beta_h

- 1 In the **Model Builder** window, under **Component 1 (comp1) > Definitions** right-click **beta_n (beta_n)** and choose **Duplicate**.
- 2 In the **Settings** window for **Analytic**, type *beta_h* in the **Label** text field.
- 3 In the **Function name** text field, type *beta_h*.
- 4 Locate the **Definition** section. In the **Expression** text field, type $27.25 / (\exp(-0.1 * (V_{\text{membrane}} / 1[\text{mV}] + 22)) + 1)$.

n_inf

- 1 In the **Model Builder** window, under **Component 1 (comp1) > Definitions** right-click **alpha_n (alpha_n)** and choose **Duplicate**.

- 2 In the **Settings** window for **Analytic**, type `n_inf` in the **Label** text field.
- 3 In the **Function name** text field, type `n_inf`.
- 4 Locate the **Definition** section. In the **Expression** text field, type `alpha_n(Vmembrane) / (alpha_n(Vmembrane)+beta_n(Vmembrane))`.
- 5 Locate the **Units** section. In the **Function** text field, type `1`.

m_inf

- 1 Right-click **n_inf** and choose **Duplicate**.
- 2 In the **Settings** window for **Analytic**, type `m_inf` in the **Label** text field.
- 3 In the **Function name** text field, type `m_inf`.
- 4 Locate the **Definition** section. In the **Expression** text field, type `alpha_m(Vmembrane) / (alpha_m(Vmembrane)+beta_m(Vmembrane))`.

h_inf

- 1 Right-click **m_inf** and choose **Duplicate**.
- 2 In the **Settings** window for **Analytic**, type `h_inf` in the **Label** text field.
- 3 In the **Function name** text field, type `h_inf`.
- 4 Locate the **Definition** section. In the **Expression** text field, type `alpha_h(Vmembrane) / (alpha_h(Vmembrane)+beta_h(Vmembrane))`.

alpha_h (alpha_h), alpha_m (alpha_m), alpha_n (alpha_n), beta_h (beta_h), beta_m (beta_m), beta_n (beta_n), h_inf (h_inf), m_inf (m_inf), n_inf (n_inf)

- 1 In the **Model Builder** window, under **Component 1 (comp1) > Definitions**, Ctrl-click to select **alpha_n (alpha_n)**, **beta_n (beta_n)**, **alpha_m (alpha_m)**, **beta_m (beta_m)**, **alpha_h (alpha_h)**, **beta_h (beta_h)**, **n_inf (n_inf)**, **m_inf (m_inf)**, and **h_inf (h_inf)**.
- 2 Right-click and choose **Group**.



Neuron Functions

In the **Settings** window for **Group**, type **Neuron Functions** in the **Label** text field.

Rectangle 1 (rect1)

- 1 In the **Definitions** toolbar, click **f(∞) More Functions** and choose **Rectangle**.
- 2 In the **Settings** window for **Rectangle**, locate the **Parameters** section.
- 3 In the **Lower limit** text field, type `-0.5[ms]`.
- 4 In the **Upper limit** text field, type `0.3[ms]`.
- 5 Click to expand the **Smoothing** section. In the **Size of transition zone** text field, type `0.1[ms]`.

Dendrite Probe

- 1 In the **Definitions** toolbar, click  **Probes** and choose **Point Probe**.
- 2 In the **Settings** window for **Point Probe**, locate the **Source Selection** section.
- 3 Click  **Clear Selection**.
- 4 Click  **Clear Selection**.
- 5 Locate the **Expression** section. In the **Expression** text field, type Vmembrane.
- 6 In the **Table and plot unit** field, type mV.
- 7 In the **Variable name** text field, type Dendrite_prb.
- 8 In the **Label** text field, type Dendrite Probe.
- 9 Select Point 8 only.

Soma Probe

- 1 Right-click **Dendrite Probe** and choose **Duplicate**.
- 2 In the **Settings** window for **Point Probe**, type Soma_prb in the **Variable name** text field.
- 3 In the **Label** text field, type Soma Probe.
- 4 Locate the **Source Selection** section. Click  **Clear Selection**.
- 5 Select Point 163 only.

Hillock Probe

- 1 Right-click **Soma Probe** and choose **Duplicate**.
- 2 In the **Settings** window for **Point Probe**, type Hillock_prb in the **Variable name** text field.
- 3 In the **Label** text field, type Hillock Probe.
- 4 Locate the **Source Selection** section. Click  **Clear Selection**.
- 5 Select Point 165 only.

AIS, Initial Probe

- 1 Right-click **Hillock Probe** and choose **Duplicate**.
- 2 In the **Settings** window for **Point Probe**, type AIS_initial_prb in the **Variable name** text field.
- 3 In the **Label** text field, type AIS, Initial Probe.
- 4 Locate the **Source Selection** section. Click  **Clear Selection**.
- 5 Select Point 168 only.

AIS, Final Probe

- 1 Right-click **AIS, Initial Probe** and choose **Duplicate**.

- 2 In the **Settings** window for **Point Probe**, type AIS_final_rpb in the **Variable name** text field.
- 3 In the **Label** text field, type AIS, Final Probe.
- 4 Locate the **Source Selection** section. Click  **Clear Selection**.
- 5 Select Point 170 only.

Axon Probe



- 1 Right-click **AIS, Final Probe** and choose **Duplicate**.
- 2 In the **Settings** window for **Point Probe**, type Axon_prb in the **Variable name** text field.
- 3 In the **Label** text field, type Axon Probe.
- 4 Locate the **Source Selection** section. Click  **Clear Selection**.
- 5 Select Point 172 only.

Add one blank material per domain and link the corresponding properties.

ADD MATERIAL

- 1 In the **Materials** toolbar, click  **Add Material** to open the **Add Material** window.
- 2 Go to the **Add Material** window.

Extracellular Solution

- 1 In the **Model Builder** window, under **Component 1 (comp1)** right-click **Materials** and choose **Blank Material**.
- 2 In the **Materials** toolbar, click  **Add Material** to close the **Add Material** window.
- 3 In the **Settings** window for **Material**, type Extracellular Solution in the **Label** text field.
- 4 Locate the **Geometric Entity Selection** section. Click  **Clear Selection**.
- 5 Select Domain 1 only.

6 Locate the **Material Contents** section. In the table, enter the following settings:

Property	Variable	Value	Unit	Property group
Electric conductivity	sigma_iso ; sigma _{ii} = sigma_iso, sigma _{ij} = 0	sigma_sol ution	S/m	Basic
Relative permittivity	epsilon _{nr_iso} ; epsilon _{nr_{ii}} = epsilon _{nr_iso} , epsilon _{nr_{ij}} = 0	epsr_wate r	1	Basic

Neuron

1 Right-click **Extracellular Solution** and choose **Duplicate**.

2 In the **Settings** window for **Material**, type Neuron in the **Label** text field.

3 Locate the **Material Contents** section. In the table, enter the following settings:

Property	Variable	Value	Unit	Property group
Electric conductivity	sigma_iso ; sigma _{ii} = sigma_iso, sigma _{ij} = 0	sigma_ne uron	S/m	Basic

4 Locate the **Geometric Entity Selection** section. Click  **Clear Selection**.

5 From the **Selection** list, choose **All domains**.

6 In the list box, select **I**.

7 From the **Selection** list, choose **Neuron**.

Use the following settings for the Electric Current interfaces and the Boundary ODE interface.

ELECTRIC CURRENTS (EC)

1 In the **Model Builder** window, under **Component 1 (comp1)** click **Electric Currents (ec)**.

2 In the **Settings** window for **Electric Currents**, click to expand the **Discretization** section.

3 From the **Electric potential** list, choose **Linear**.

4 Click to expand the **Dependent Variables** section. In the **Electric potential (V)** text field, type Vout.

5 Locate the **Domain Selection** section. Click  **Clear Selection**.

6 Select Domain 1 only.

Ground 1

1 In the **Physics** toolbar, click  **Boundaries** and choose **Ground**.

2 Select Boundary 4 only.

Normal Current Density 1

1 In the **Physics** toolbar, click  **Boundaries** and choose **Normal Current Density**.

2 In the **Settings** window for **Normal Current Density**, locate the **Boundary Selection** section.

3 From the **Selection** list, choose **Neuron Boundary**.

4 Locate the **Normal Current Density** section. In the J_n text field, type $ICm+INa+IK+IL$.

Boundary Terminal 1

1 In the **Physics** toolbar, click  **Boundaries** and choose **Boundary Terminal**.

2 In the **Settings** window for **Boundary Terminal**, locate the **Boundary Selection** section.

3 From the **Selection** list, choose **Box Selection 1 (Work Plane 6)**.

Boundary Terminal 23

Right-click **Boundary Terminal 1** and choose **Split by Connectivity**.

ELECTRIC CURRENTS 2 (EC2)

1 In the **Settings** window for **Electric Currents**, locate the **Domain Selection** section.

2 From the **Selection** list, choose **Neuron**.

3 Locate the **Discretization** section. From the **Electric potential** list, choose **Linear**.

4 Locate the **Dependent Variables** section. In the **Electric potential (V)** text field, type Vin .

Normal Current Density 1

In the **Physics** toolbar, click  **Boundaries** and choose **Normal Current Density**.

Initial Values 1

1 In the **Model Builder** window, click **Initial Values 1**.

2 In the **Settings** window for **Initial Values**, locate the **Initial Values** section.

3 In the Vin text field, type Vr .

Normal Current Density 1

1 In the **Model Builder** window, click **Normal Current Density 1**.

2 In the **Settings** window for **Normal Current Density**, locate the **Boundary Selection** section.

3 From the **Selection** list, choose **Neuron Boundary**.

4 Locate the **Normal Current Density** section. In the J_n text field, type $-IC_m - IL - IK - IN_a$.

Normal Current Density 2

- 1 In the **Physics** toolbar, click  **Boundaries** and choose **Normal Current Density**.
- 2 In the **Settings** window for **Normal Current Density**, locate the **Normal Current Density** section.
- 3 In the J_n text field, type $I_{stim} * rect1(t)$.
- 4 Locate the **Boundary Selection** section. From the **Selection** list, choose **Dendrite Boundary**.

BOUNDARY ODES AND DAES (BODE)

- 1 In the **Model Builder** window, under **Component 1 (comp1)** click **Boundary ODEs and DAEs (bode)**.
- 2 In the **Settings** window for **Boundary ODEs and DAEs**, locate the **Boundary Selection** section.
- 3 From the **Selection** list, choose **Neuron Boundary**.
- 4 Click to expand the **Discretization** section. From the **Element order** list, choose **Linear**.
- 5 Locate the **Units** section. In the **Source term quantity** table, enter the following settings:

Source term quantity	Unit
Custom unit	s^{-1}

- 6 Click to expand the **Dependent Variables** section. In the **Dependent variables (1)** table, enter the following settings:

n

- 7 Click  **Add Dependent Variable**.

- 8 In the **Dependent variables (1)** table, enter the following settings:

n
m

- 9 Click  **Add Dependent Variable**.

- 10 In the **Dependent variables (1)** table, enter the following settings:

n
m
h

Distributed ODE 1

- 1 In the **Model Builder** window, under **Component 1 (comp1) > Boundary ODEs and DAEs (bode)** click **Distributed ODE 1**.
- 2 In the **Settings** window for **Distributed ODE**, locate the **Source Term** section.
- 3 In the f text-field array, type $\alpha_n(V_{\text{membrane}}) * (1 - n) - \beta_n(V_{\text{membrane}}) * n$ on the first row.
- 4 In the f text-field array, type $\alpha_m(V_{\text{membrane}}) * (1 - m) - \beta_m(V_{\text{membrane}}) * m$ on the second row.
- 5 In the f text-field array, type $\alpha_h(V_{\text{membrane}}) * (1 - h) - \beta_h(V_{\text{membrane}}) * h$ on the third row.

Initial Values 1

- 1 In the **Model Builder** window, click **Initial Values 1**.
- 2 In the **Settings** window for **Initial Values**, locate the **Initial Values** section.
- 3 In the n text field, type $n_{\text{inf}}(V_r)$.
- 4 In the m text field, type $m_{\text{inf}}(V_r)$.
- 5 In the h text field, type $h_{\text{inf}}(V_r)$.

Next, build the computational mesh as follows.

MESH 1

- 1 In the **Model Builder** window, under **Component 1 (comp1)** click **Mesh 1**.
- 2 In the **Settings** window for **Mesh**, locate the **Physics-Controlled Mesh** section.
- 3 From the **Element size** list, choose **Coarse**.
- 4 Locate the **Sequence Type** section. From the list, choose **User-controlled mesh**.



Size

- 1 In the **Model Builder** window, under **Component 1 (comp1) > Mesh 1** click **Size**.
- 2 In the **Settings** window for **Size**, locate the **Element Size Parameters** section.
- 3 In the **Minimum element size** text field, type $t_{\text{cleft}}/3$.



Size 1, Size 2

- 1 In the **Model Builder** window, under **Component 1 (comp1) > Mesh 1**, Ctrl-click to select **Size 1** and **Size 2**.
- 2 Right-click and choose **Delete**.

Size 1

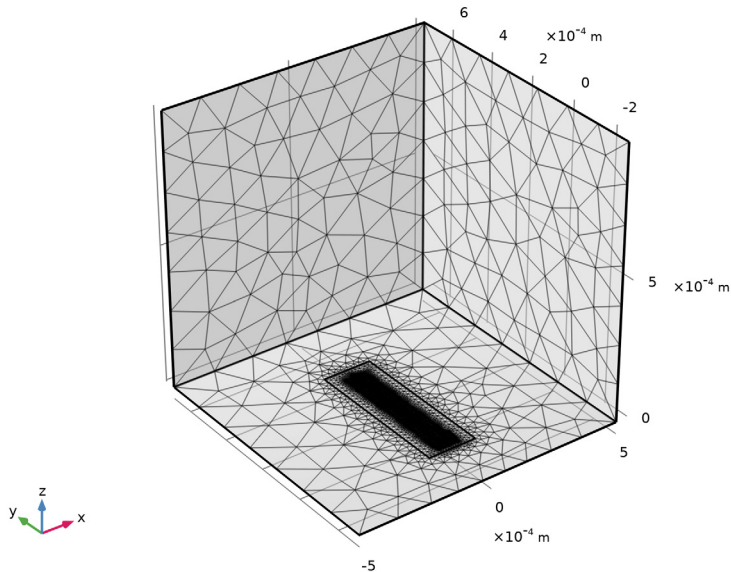
- 1 In the **Model Builder** window, expand the **Component 1 (comp1) > Mesh 1 > Free Tetrahedral 1** node.
- 2 Right-click **Free Tetrahedral 1** and choose **Size**.
- 3 In the **Settings** window for **Size**, locate the **Geometric Entity Selection** section.
- 4 From the **Geometric entity level** list, choose **Edge**.
- 5 Select Edges 213, 216, 221, 227, and 231 only.
- 6 Locate the **Element Size** section. Click the **Custom** button.
- 7 Locate the **Element Size Parameters** section.
- 8 Select the **Maximum element size** checkbox. In the associated text field, type `pitch_ele`.
- 9 Select the **Minimum element size** checkbox. In the associated text field, type `t_cleft/3`.
- 10 Click the  **Transparency** button in the **Graphics** toolbar.
- 11 In the **Model Builder** window, right-click **Mesh 1** and choose **Build All**.
- 12 Click the  **Zoom Extents** button in the **Graphics** toolbar.



- 13 Click the  **Click and Hide** button in the **Graphics** toolbar.
- 14 In the **Graphics** window toolbar, click  next to  then choose **Select Boundaries**.

- 15 Select Boundary 3 only.
- 16 Select Boundary 190 only.
- 17 Select Boundary 5 only.
- 18 Click the  **Zoom Extents** button in the **Graphics** toolbar.

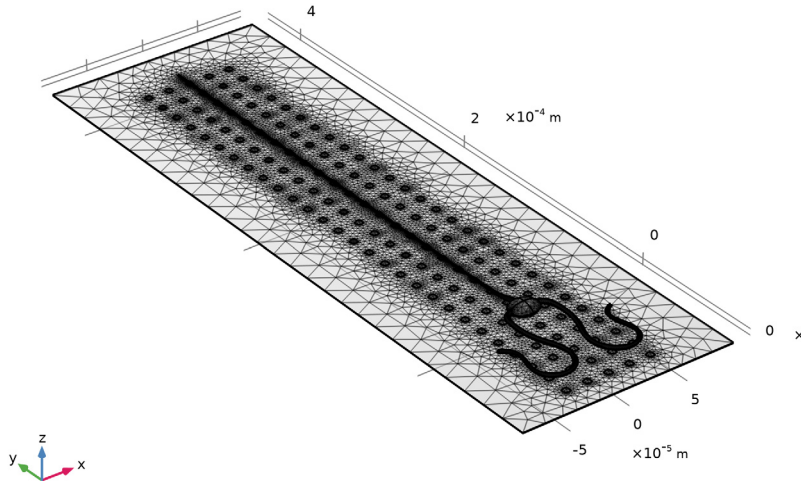

Finally, specify study settings and compute.

STUDY I

- 1 In the **Model Builder** window, click **Study I**.
- 2 In the **Settings** window for **Study**, locate the **Study Settings** section.
- 3 Clear the **Generate default plots** checkbox.

Step 1: Time Dependent

- 1 In the **Model Builder** window, under **Study I** click **Step 1: Time Dependent**.
- 2 In the **Settings** window for **Time Dependent**, locate the **Study Settings** section.
- 3 From the **Time unit** list, choose **ms**.
- 4 In the **Output times** text field, type range (0,0.01,2).

Solution 1 (sol1)

- 1 In the **Study** toolbar, click  **Show Default Solver**.



- 2 In the **Model Builder** window, expand the **Solution 1 (sol1)** node.
- 3 In the **Model Builder** window, under **Study 1 > Solver Configurations > Solution 1 (sol1)** click **Time-Dependent Solver 1**.
- 4 In the **Settings** window for **Time-Dependent Solver**, click to expand the **Time Stepping** section.
- 5 From the **Steps taken by solver** list, choose **Intermediate**.
- 6 Right-click **Study 1 > Solver Configurations > Solution 1 (sol1) > Time-Dependent Solver 1** and choose **Fully Coupled**.
- 7 In the **Study** toolbar, click  **Compute**.

RESULTS

Study 1/Solution 1 (sol1)

In the **Model Builder** window, expand the **Results > Datasets** node, then click **Study 1/Solution 1 (sol1)**.

Selection

- 1 In the **Results** toolbar, click  **Attributes** and choose **Selection**.
- 2 In the **Settings** window for **Selection**, locate the **Geometric Entity Selection** section.
- 3 From the **Geometric entity level** list, choose **Boundary**.
- 4 Click the  **Select All** button in the **Graphics** toolbar.
- 5 Select Boundaries 6–188 only.

Action Potential Generation and Propagation

- 1 In the **Model Builder** window, expand the **Results > Probe Plot Group 1** node, then click **Probe Plot Group 1**.
- 2 In the **Settings** window for **ID Plot Group**, type Action Potential Generation and Propagation in the **Label** text field.
- 3 Locate the **Plot Settings** section.
- 4 Select the **y-axis label** checkbox. In the associated text field, type Membrane potential (mV).
- 5 Locate the **Legend** section. From the **Position** list, choose **Upper left**.

Probe Table Graph 1

- 1 In the **Model Builder** window, click **Probe Table Graph 1**.
- 2 In the **Settings** window for **Table Graph**, locate the **Coloring and Style** section.
- 3 Find the **Line style** subsection. From the **Line** list, choose **Cycle (reset)**.

4 From the **Width** list, choose **2**.

5 Click the  **Zoom Extents** button in the **Graphics** toolbar.

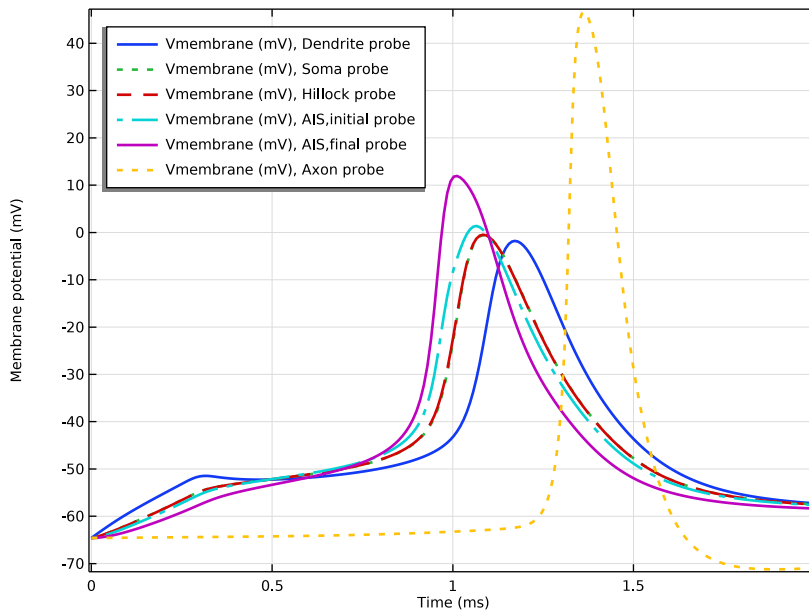

Electric Potential at MEA Plane

1 In the **Results** toolbar, click  **3D Plot Group**.

2 In the **Settings** window for **3D Plot Group**, type **Electric Potential at MEA Plane** in the **Label** text field.

3 Locate the **Data** section. From the **Time (ms)** list, choose **Interpolation**.

4 In the **Time** text field, type **1.12**.

Surface 1

1 Right-click **Electric Potential at MEA Plane** and choose **Surface**.

2 In the **Electric Potential at MEA Plane** toolbar, click  **Plot**.

3 Click the  **Zoom Extents** button in the **Graphics** toolbar.

4 In the **Model Builder** window, click **Surface 1**.

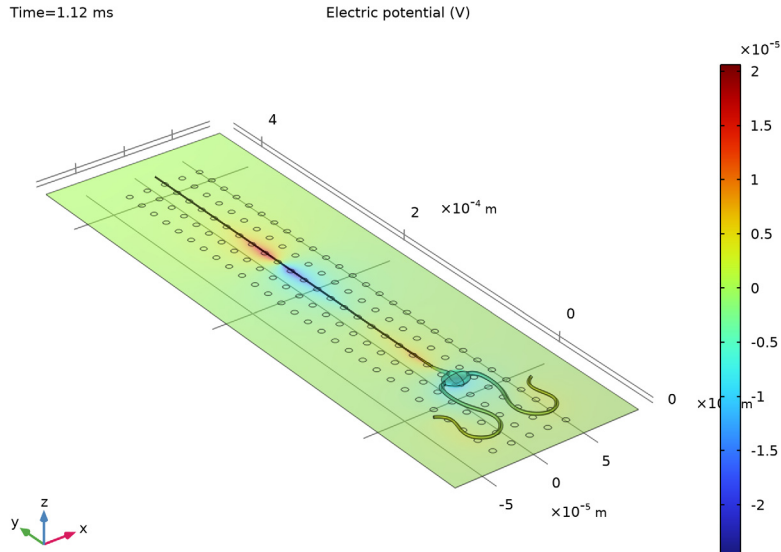

Recorded Signals at Electrodes

- 1 In the **Results** toolbar, click  **ID Plot Group**.
- 2 In the **Settings** window for **ID Plot Group**, type Recorded Signals at Electrodes in the **Label** text field.
- 3 Click to expand the **Title** section. From the **Title type** list, choose **Label**.
- 4 Locate the **Legend** section. From the **Position** list, choose **Lower left**.

Global 1

- 1 Right-click **Recorded Signals at Electrodes** and choose **Global**.
- 2 In the **Settings** window for **Global**, click to expand the **Coloring and Style** section.
- 3 Find the **Line style** subsection. From the **Line** list, choose **Cycle**.
- 4 From the **Width** list, choose **2**.
- 5 Locate the **y-Axis Data** section. In the table, enter the following settings:

Expression	Unit	Description
ec.V0_1	uV	Terminal voltage
ec.V0_2	uV	Terminal voltage
ec.V0_3	uV	Terminal voltage

Expression	Unit	Description
ec.V0_4	uV	Terminal voltage
ec.V0_5	uV	Terminal voltage
ec.V0_11	uV	Terminal voltage
ec.V0_17	uV	Terminal voltage
ec.V0_23	uV	Terminal voltage

6 Click to expand the **Legends** section. From the **Legends** list, choose **Manual**.

7 In the table, enter the following settings:

Legends
Soma
Hillock
AIS initial
AIS final
Axon initial
Axon 1/3
Axon 2/3
Axon final

8 In the **Recorded Signals at Electrodes** toolbar, click  **Plot**.

9 Click the  **Zoom Extents** button in the **Graphics** toolbar.

